

N 70, Integrated box hood, 60 cm, clear glass white printed  
D64XAF8NOB



COOKING PASSION SINCE 1877



B



Our invisible integrated canopy box hood - perfectly integrated with extra storage for easy access items, such as spices and herbs.

- ✓ LED lighting: a clear illumination whilst cooking thanks to the energy-saving LED lights
- ✓ Hidden Design – integrate your hood seamlessly and blend it top to bottom with our flush-fitted design in your cupboard
- ✓ Extra Storage – the hood's T-shaped body makes more of your cabinet with extra space for many large and handy items
- ✓ High extraction rate: Ensures a clear view while cooking thanks to efficient motor technology as either a ducted or recirculating solution.

#### Features

##### Technical Data

Color chimney : Stainless steel  
 Approval certificates : CE  
 Length electrical supply cord (cm) : 150  
 Required niche size for installation (HxWxD) : 356mm x 562mm x 310mm  
 Height of product, without chimney (mm) : 60  
 Minimum distance above an electric hob : 500  
 Minimum distance above a gas hob : 500  
 Net weight (kg) : 10.996  
 Type of control : mechanical  
 Number of speed settings : 3  
 Maximum output air extraction (m<sup>3</sup>/h) : 610  
 Maximum output recirculating air (m<sup>3</sup>/h) : 440  
 Number of lights : 2  
 Noise level (dB(A) re 1 pW) : 70  
 Diameter of air outlet (mm) : 150  
 Grease filter material : Washable aluminium  
 EAN code : 4242004243618  
 Connection Rating (W) : 255  
 Voltage (V) : 220-240  
 Frequency (Hz) : 50; 60

#### Optional accessories

Z51MA0X0 Active carbon filter  
 Z51ITP0X0 CleanAir act.carbon filter regenerative  
 Z54TR00X0 CleanAir active carbon filter  
 Z54TR60X3 CleanAir Recirculation Kit



4 242004 243618

*N 70, Integrated box hood, 60 cm, clear glass white  
printed  
D64XAF8NOB*

## Features

### Key performance features:

- Energy Efficiency Class: B (at a range of energy efficiency classes from A++ to E)\*
- Extraction rate according to EN 61591 max. 610 m<sup>3</sup>/h
- Noise max. Normal Level: 70 dB\*

### Features

- 3 power levels via rotary switch, retractable
- White with LED backlit glass panel
- 2 x LED 2.5W
- Colour Temperature: 3500 K
- Filter cover glass, metal grease filter
- 1 metal grease filter cassette
- For installation in a kitchen cabinet

### Design

- Adjustable glass visor for additional vapour capture
- Filler strip for an individual depth adjustment in cupboard up to maximum 350 mm.
- Mechanical controls

### Performance/technical information

- Suitable for ducted extraction and recirculation
- For recirculated extraction recirculating kit or CleanAir recirculating kit (accessory) needed
- Max. extraction rate: 610 m<sup>3</sup>/h
- Extraction rate according to EN 61591 max. 610 m<sup>3</sup>/h
- Noise max. Normal Level: 70 dB\*
- Noise level according to EN 60704-3 and EN 60704-2-13 at max. normal use exhaust air: 70 dB(A) re 1 pW (57 dB(A) re 20 µPa sound pressure)
- 
- Light Intensity: 76 lux
- Colour Temperature: 3500 K
- Electrical cable length 1.5 m
- Diameter pipe Ø 150 mm (Ø 150 mm enclosed)
- Dimensions (HxWxD): 356 x 594 x 310 mm
- Built-in dimensions (HxWxD): 356 x 562 x 310-350 mm
- Energy Efficiency Class: B (at a range of energy efficiency classes from A++ to E)\*
- Blower Efficiency Class: B\*
- Lighting Efficiency Class: A\*
- Grease Filtering Efficiency Class: C\*
- Average Energy Consumption: 61 kWh/year\*

### Optional accessories

- Recirculating kit

\* In accordance with the EU-Regulation No 65/2014

N 70, Integrated box hood, 60 cm, clear glass white printed  
D64XAF8NOB

Dimensioned drawings

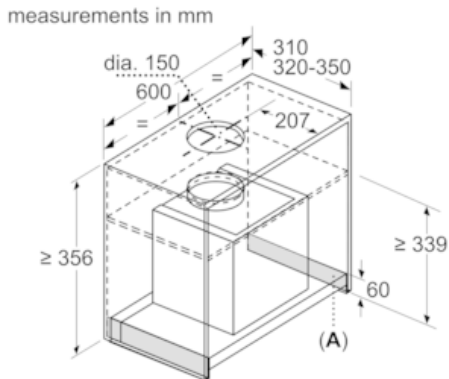

A: Area without hinge

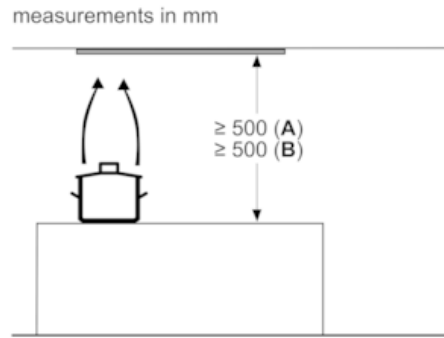

\*from upper edge of pan support  
A: Electric min. 500 mm  
B: Gas min. 500 mm

