

N 90, Built-in compact oven with steam function, Stainless steel
C18FT56H0B



COOKING PASSION SINCE 1877



Compact built-in oven with FullSteam - combining all heating types and steam cooking in a single oven in a very small space

- ✓ The new FullSteam® oven combines CircoTherm® oven and steam cooker in a single unit.
- ✓ FullTouch Control - simple, precise oven control by fingertip touch on the smooth surface of the high resolution TFT colour display.
- ✓ EcoClean - the self-cleaning catalytic coating on the inside top and sides of the oven makes oven cleaning easier.
- ✓ BaseClean - the special cleaning programme for the oven floor.
- ✓ Sous-vide - prepare vacuum-sealed dishes with FullSteam for a new horizon of flavour.
- ✓ Home Connect – rediscover your kitchen with our connected home appliances, from wherever you are.

A+

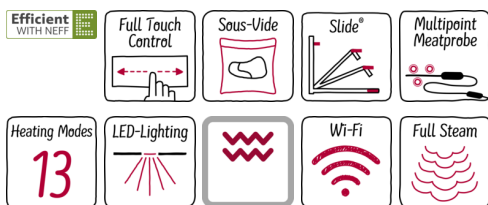

Features

Technical Data

Color / Material Front : Stainless steel
 Construction type : Built-in
 Door opening : Drop down
 Required niche size for installation (HxWxD) : 450-455 x 560-568 x 550
 Dimensions of the product (mm) : 455 x 596 x 548
 Dimensions of the packed product (HxWxD) (mm) : 540 x 660 x 690
 Control Panel Material : Stainless steel
 Door Material : Glass
 Net weight (kg) : 34.983
 Approval certificates : CE, VDE
 Length of electrical supply cord (cm) : 150
 EAN code : 4242004236412
 Current (A) : 16
 Voltage (V) : 220-240
 Frequency (Hz) : 50; 60
 Plug type : no plug
 Approval certificates : CE, VDE
 Number of cavities (2010/30/EC) : 1
 Usable volume (of cavity) - NEW (2010/30/EC) : 47
 Energy efficiency class (2010/30/EC) : A+
 Energy consumption per cycle conventional (2010/30/EC) : 0.73
 Energy consumption per cycle forced air convection (2010/30/EC) : 0.61
 Energy efficiency index (2010/30/EC) : 81.3

Optional accessories

Z11AB10A0 : Baking tray, non-stick coated , Z11GT10X3 : Glass roasting dish, 5,4l , Z11GU20X0 : Glasspan , Z11SZ00X0 : SeamlessCombination mounting kit , Z11SZ60X0 : SeamlessCombination 45 + 14cm , Z11SZ90X0 : SeamlessCombination 60 + 45cm , Z12CB10A0 : Baking tray, anthracite enamelled , Z12CM10A0 : Moussaka pan, anthracite enamelled , Z12CQ10A0 : Grill tray, anthracite enamelled , Z13CV06S0 : Decor strip , Z13CX62X0 : Vacuum bags 180 x 280 mm, 100 pcs. , Z13CX64X0 : Vacuum bags 240 x 350 mm, 100 pcs. , Z13TC10X0 : ComfortFlex Rail (1 level) f. steam , Z13TC14X0 : ComfortFlex Rail (1 level) f. steam , Z1665X0 : porcelain tray-GN1/3- unpunched , Z1685X0 : porcelain tray-GN2/3- unpunched , Z18F45X0 : Cookbook , Z1913X0 : Baking Stone



*N 90, Built-in compact oven with steam function,
Stainless steel
C18FT56H0B*

Features

Design

- 5.7" TFT colour and graphics display with FullTouch control
- Touch control
- electronic clock
- Drop down door, SoftClose, soft opening
- Slide&Hide® with rotating handle
- Cavity inner surface: Enamel anthracite

Features

- HomeConnect ready on WLAN
- Control panel lock
Automatic safety switch off
Residual heat indicator
Start button
Door contact switch
- Temperature proposal
Actual temperature display
Heating up indicator
Sabbath setting
- Intelligent microwave inverter technology: For optimised results maximum output power will be regulated to 600 W when used in longer operation for gentler cooking.
- automatic programmes: 30
- Baking and roasting assistant, Automatic programmes
- MultiPoint MeatProbe
- LED light
- On/off button
- 3 shelf positions
- Cooling fan

Cleaning

- EcoClean Direct : ceiling, back panel, side liners
- EcoClean programme, Base Clean programme
- Full glass inner door

Programmes/functions

- Compact steam oven with 13 heating methods: CircoTherm®, CircoTherm® Gentle, Top/bottom heat, Conventional heat Gentle, Hot air grilling, Full surface grill, Centre surface grill, CircoTherm®

intensive , Bread baking, Bottom heat, Low temperature cooking, Plate warming, Keep warm

- Steaming 40 °C to 100 °C, 40 °C to 200 °C, 40 °C to 200 °C, Reheat, Dough proving, Defrost
- Additional heating methods with steam: Steaming, Reheat, Dough proving, Defrost
- Microwave may be used separately or in combination
- Additional functions:
De-scaling programme
Drying function
Automatic boiling point detection
- automatic programmes: 30
- Rapid heat

Standard accessories

- 1 x steam container, punched, size S, 1 x steam container, punched, size XL, 1 x steam container, unpunched, size S, 1 x grid, 1 x universal pan

Technical information

- Energy efficiency rating (acc. EU Nr. 65/2014): A+
Energy consumption per cycle in conventional mode: 81.3
Energy consumption per cycle in fan-forced convection mode: 0.61 kwh
Number of cavities: 1
Cavity volume: 47 litre
- Cavity volume: 47 l
- Temperature range 40 °C - 250 °C
- 1 l Water tank capacity
- Water tank empty indicator
- Location of the steam generator is outside of the cavity
- Length of mains cable: 150 cm
- Total connected load electric: 3.3 KW
- Nominal voltage: 220 - 240 V
- Appliance dimension (hxwxd): 455 mm x 596 mm x 548 mm
- Niche dimension (hxwxd): 450 mm - 455 mm x 560 mm - 568 mm x 550 mm
- Please refer to the dimensions provided in the installation manual

N 90, Built-in compact oven with steam function,
Stainless steel
C18FT56HOB

Dimensioned drawings

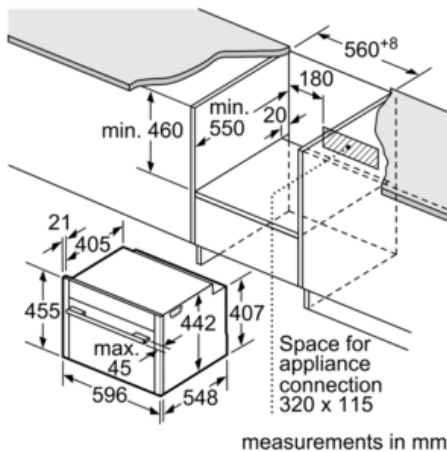

If the compact appliance will be installed underneath a hob, the following worktop thicknesses (including substructure if necessary) must be taken into account.

Hob type	min. worktop thickness	
	fitted	flush
Induction hob	42 mm	43 mm
Full surface Induction hob	52 mm	53 mm
Gas hob	32 mm	43 mm
Electric hob	32 mm	35 mm

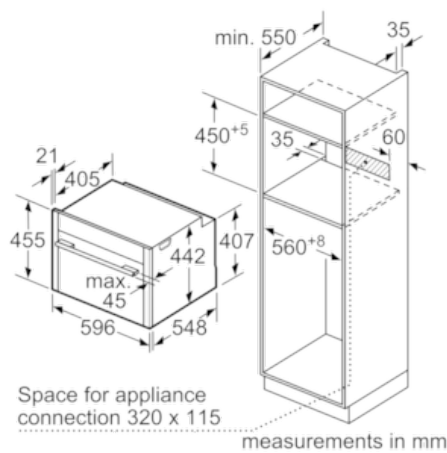

Installation with a hob.

