

N 90, Built-in oven with steam function, Stainless steel
B48FT78H0B



COOKING PASSION SINCE 1877



A+

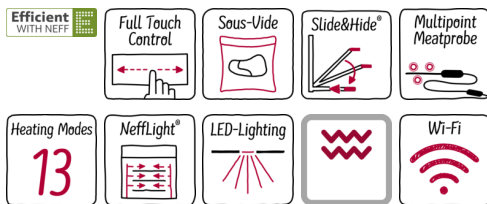

Built-in oven with FullSteam and SLIDE&HIDE® - combining all heating types and steam cooking in a single oven with unrestricted access

- ✓ Hide® - the fully retracting oven door
- ✓ The new FullSteam® oven combines CircoTherm® oven and steam cooker in a single unit.
- ✓ Sous-vide - prepare vacuum-sealed dishes with FullSteam for a new horizon of flavour.
- ✓ FullTouch Control - simple, precise oven control by fingertip touch on the smooth surface of the high resolution TFT colour display.
- ✓ Home Connect – rediscover your kitchen with our connected home appliances, from wherever you are.

Features

Technical Data

Color / Material Front : Stainless steel
 Construction type : Built-in
 Door opening : Drop down
 Required niche size for installation (HxWxD) : 585-595 x 560-568 x 550
 Dimensions of the product (mm) : 595 x 596 x 548
 Dimensions of the packed product (HxWxD) (mm) : 670 x 660 x 690
 Control Panel Material : Stainless steel
 Door Material : Glass
 Net weight (kg) : 43.249
 Approval certificates : CE, VDE
 Length of electrical supply cord (cm) : 120
 EAN code : 4242004236061
 Current (A) : 16
 Voltage (V) : 220-240
 Frequency (Hz) : 50; 60
 Plug type : no plug
 Approval certificates : CE, VDE
 Number of cavities (2010/30/EC) : 1
 Usable volume (of cavity) - NEW (2010/30/EC) : 71
 Energy efficiency class (2010/30/EC) : A+
 Energy consumption per cycle conventional (2010/30/EC) : 0.87
 Energy consumption per cycle forced air convection (2010/30/EC) : 0.69
 Energy efficiency index (2010/30/EC) : 81.2

Optional accessories

Z11AB10A0 : Baking tray, non-stick coated , Z11GT10X3 : Glass roasting dish, 5,4l , Z11GU20X0 : Glasspan , Z11SZ00X0 : SeamlessCombination mounting kit , Z11SZ80X0 : SeamlessCombination 60 + 29cm , Z11SZ90X0 : SeamlessCombination 60 + 45cm , Z12CB10A0 : Baking tray, anthracite enamelled , Z12CM10A0 : Moussaka pan, anthracite enamelled , Z12CQ10A0 : Grill tray, anthracite enamelled , Z13CX62X0 : Vacuum bags 180 x 280 mm, 100 pcs. , Z13CX64X0 : Vacuum bags 240 x 350 mm, 100 pcs. , Z13TC10X0 : ComfortFlex Rail (1 level) f. steam , Z1665X0 : porcelain tray-GN1/3- unpunched , Z1685X0 : porcelain tray-GN2/3- unpunched , Z18F60X0 : Cookbook , Z1913X0 : Baking Stone



N 90, Built-in oven with steam function, Stainless steel
B48FT78H0B

Features

Design

- 5.7" TFT colour and graphics display with FullTouch control
- Touch control
- Cavity inner surface: Enamel anthracite
- Slide&Hide® with fixed handle, SoftOpen
- Slide&Hide® with rotating handle

Features

- HomeConnect ready on WLAN
- Control panel lock
 - Automatic safety switch off
 - Residual heat indicator
 - Start button
 - Door contact switch
- Temperature proposal
 - Actual temperature display
 - Heating up indicator
 - Sabbath setting
- MultiPoint MeatProbe
- Baking and roasting assistant, Automatic programmes
- NeffLight (2 x 20 Watt halogen lamps) , LED light
- Water tank empty indicator
- Triple glazed door

Cleaning

- EcoClean Direct : ceiling, side liners, back panel
- EcoClean programme, Base Clean programme
- De-scaling programme
- Full glass inner door

Programmes/functions

- Combi-steam oven with 13 heating methods: CircoTherm®, CircoTherm® Gentle, Top/bottom heat, Conventional heat Gentle, Hot air grilling, Full surface grill, Centre surface grill, CircoTherm® intensive , Bread baking, Bottom heat, Low temperature cooking, Plate warming, Keep warm, Steaming, Reheat, Dough proving, Defrost, Sous-vide cooking
- Additional functions:
 - De-scaling programme
 - Drying function
 - Automatic boiling point detection
- Number of automatic programmes: 30 PC
- Rapid heat
- Cooling fan

Accessories

- 1-level flexible telescopic rail, full extension, Stop function
- 1 x steam container, punched, size S, 1 x steam container, punched, size XL, 1 x steam container, unpunched, size S, 1 x grid, 1 x universal pan

Performance/technical information

- Energy efficiency rating (acc. EU Nr. 65/2014): A+
 - Energy consumption per cycle in conventional mode: 0.87 kwh
 - Energy consumption per cycle in fan-forced convection mode: 0.69 kwh
 - Number of cavities: Main cavity
 - Heat source: electrical
 - Cavity volume: 71 litre
- 1 l Water tank capacity
- Location of the steam generator is outside of the cavity
- Total connected load electric: 3.45 KW
- Temperature range 40 °C - 250 °C
- Length of mains cable: 120 cm
- Nominal voltage: 220 - 240 V
- Appliance dimension (hxwxh): 595 mm x 596 mm x 548 mm
- Niche dimension (hxwxh): 585 mm - 595 mm x 560 mm - 568 mm x 550 mm
- Please refer to the dimensions provided in the installation manual

N 90, Built-in oven with steam function, Stainless steel
B48FT78HOB

Dimensioned drawings

Installation with a hob.

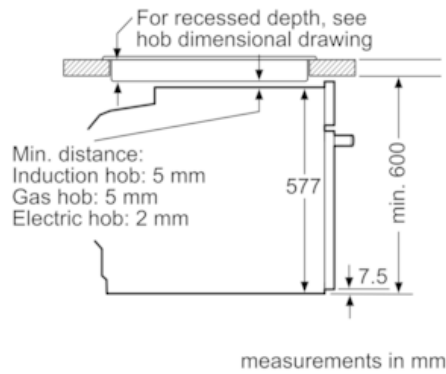

If the appliance will be installed underneath a hob, the following worktop thicknesses (including substructure if necessary) must be taken into account.

Hob type	min. worktop thickness	
	fitted	flush
Induction hob	37 mm	38 mm
Full surface Induction hob	47 mm	48 mm
Gas hob	30 mm	38 mm
Electric hob	27 mm	30 mm

