

N 70, built-in oven with steam-function, Stainless steel
B47VR32NOB



COOKING PASSION SINCE 1877



A+

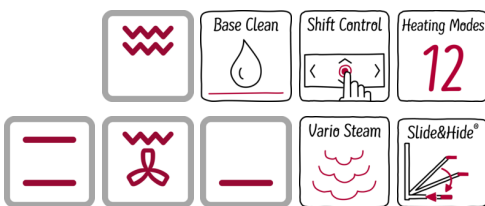

Built-in oven with VarioSteam® and SLIDE&HIDE® - fuller flavour and unrestricted access to the oven interior

- ✓ Slide&Hide® - unrestricted access in the oven interior and easy handling due to rotating handle
- ✓ CircoTherm® - the unique hot air-system for simultaneous baking and roasting on up to 3 levels
- ✓ VarioSteam® - Steam assistance for CircoTherm® ovens, that cooks foods moist on the inside and crisp on the outside
- ✓ EcoClean - the self-cleaning catalytic coating on the sides of your oven make cleaning the inside easier.
- ✓ EasyClean - the quick and easy option for day-to-day maintenance
- ✓ BaseClean - a special cleaning programme designed to help clean the base of the oven
- ✓ Shift Control - fast navigation through menus and simple operation with the TFT display.
- ✓ Modern LED lighting for bright, even illumination

Features

Technical Data

Color / Material Front : Stainless steel
 Built-in / Free-standing : Built-in
 Integrated Cleaning system : Ecolyse coating all sides, Hydrolytic
 Required niche size for installation (HxWxD) : 585-595 x 560-568 x 550
 Dimensions of the product (mm) : 595 x 596 x 548
 Dimensions of the packed product (HxWxD) (mm) : 670 x 700 x 660
 Control Panel Material : Stainless steel
 Door Material : Glass
 Net weight (kg) : 39.530
 Usable volume (of cavity) - cavity 1 (l) : 71
 Cooking method : , 4D hot air, Bottom heat, Bread Baking Setting, Conventional heat, Full width grill, Half width grill, Hot Air-Eco, Hot air grilling, low temperature cooking, Pizza setting, warming
 First cavity material : Enamelled
 Temperature control : electronic
 Number of interior lights : 1
 Approval certificates : CE, VDE
 Length electrical supply cord (cm) : 120
 EAN code : 4242004181644
 Number of cavities (2010/30/EC) : 1
 Energy efficiency class (2010/30/EC) : A+
 Energy consumption per cycle conventional (2010/30/EC) : 0.87
 Energy consumption per cycle forced air convection (2010/30/EC) : 0.69
 Energy efficiency index (2010/30/EC) : 81.2
 Electrical connection rating (W) : 3450
 Current (A) : 16
 Voltage (V) : 220-240
 Frequency (Hz) : 60; 50
 Plug type : no plug

Included accessories

2 x combination grid, 1 x universal pan

Optional accessories

Z11AB10A0 : Baking tray, non-stick coated , Z11CR10X0 : Baking and roasting grid (standard) , Z11GT10X3 : Glass roasting dish, 5,4l , Z11GU20X0 : Glasspan , Z11SZ00X0 : SeamlessCombination mounting kit , Z11SZ80X0 : SeamlessCombination 60 + 29cm , Z11SZ90X0 : SeamlessCombination 60 + 45cm , Z11TC10X0 : ComfortFlex Rail (1 level) , Z11TC16X0 : ComfortFlex Rail (1 level) , Z11TF36X0 : 3 level telescopic rails, full ext , Z12CB10A0 : Baking tray, anthracite enamelled , Z12CM10A0 : Moussaka pan, anthracite enamelled , Z12CQ10A0 : Grill tray, anthracite enamelled , Z18V60X0 : Cookbook , Z1913X0 : Baking Stone



N 70, built-in oven with steam-function, Stainless steel
B47VR32NOB

Features

Design

- 2.5" TFT colour display
- Illuminated Shift Control
- Cavity inner surface: Enamel anthracite
- Slide&Hide® with rotating handle

Features

- Control panel lock
 - Automatic safety switch off
 - Residual heat indicator
 - Start button
 - Door contact switch
- Temperature proposal
 - Actual temperature display
 - Heating up indicator
 - Sabbath setting
- Automatic programmes
- LED light
- Water tank empty indicator
- Triple glazed door

Cleaning

- EcoCleanDirect : ceiling, back panel, side liners
- EcoClean programme, Base Clean programme
- De-scaling programme
- Full glass inner door

Programmes/functions

- 12 heating methods: CircoTherm®, CircoTherm® Gentle, Top/bottom heat, Conventional heat Gentle, Hot air grilling, Full surface grill, Centre surface grill, CircoTherm® intensive, Bread baking, Bottom heat, Low temperature cooking, Keep warm
- Additional heating methods with steam: Reheat, Dough proving
- Additional functions:
 - De-scaling programme
 - Drying function
- Number of automatic programmes: 14 PC
- Rapid heat
- Cooling fan

Accessories

- 2 x combination grid, 1 x universal pan

Performance/technical information

- Energy efficiency rating (acc. EU Nr. 65/2014): A+
 - Energy consumption per cycle in conventional mode: 0.87 kwh
 - Energy consumption per cycle in fan-forced convection mode: 0.69 kwh
 - Number of cavities: Main cavity
 - Heat source: electrical
 - Cavity volume: 71 litre
- 1 l Water tank capacity
- Location of the steam generator is outside of the cavity
- Total connected load electric: 3.45 KW
- Temperature range 40 °C - 275 °C
- Length of mains cable: 120 cm
- Nominal voltage: 220 - 240 V
- Appliance dimension (hxwxd): 595 mm x 596 mm x 548 mm
- Niche dimension (hxwxd): 585 mm - 595 mm x 560 mm - 568 mm x 550 mm
- Please refer to the dimensions provided in the installation manual

N 70, built-in oven with steam-function, Stainless steel
B47VR32NOB

Dimensioned drawings

Installation with a hob.

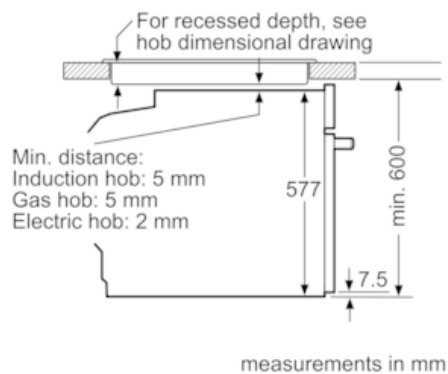

If the appliance will be installed underneath a hob, the following worktop thicknesses (including substructure if necessary) must be taken into account.

Hob type	min. worktop thickness	
	fitted	flush
Induction hob	37 mm	38 mm
Full surface Induction hob	47 mm	48 mm
Gas hob	30 mm	38 mm
Electric hob	27 mm	30 mm