

N 90, Built-in oven with steam function, Stainless steel
B47FS34H0B



COOKING PASSION SINCE 1877



A+

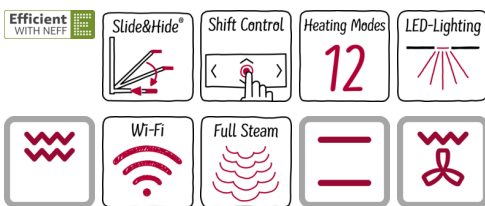

Built-in oven with FullSteam and SLIDE&HIDE® - combining all heating types and steam cooking in a single oven with unrestricted access

- ✓ Hide® - the fully retracting oven door
- ✓ The new FullSteam® oven combines CircoTherm® oven and steam cooker in a single unit.
- ✓ EcoClean - the self-cleaning catalytic coating on the inside top and sides of the oven makes oven cleaning easier.
- ✓ BaseClean - the special cleaning programme for the oven floor.
- ✓ Shift Control - fast navigation through menus and simple operation with the generous TFT display.
- ✓ Home Connect – rediscover your kitchen with our connected home appliances, from wherever you are.

Features

Technical Data

Color / Material Front : Stainless steel
 Construction type : Built-in
 Door opening : Drop down
 Required niche size for installation (HxWxD) : 585-595 x 560-568 x 550
 Dimensions of the product (mm) : 595 x 596 x 548
 Dimensions of the packed product (HxWxD) (mm) : 670 x 660 x 680
 Control Panel Material : Stainless steel
 Door Material : Glass
 Net weight (kg) : 36.071
 Approval certificates : CE, VDE
 Length of electrical supply cord (cm) : 120
 EAN code : 4242004236047
 Current (A) : 16
 Voltage (V) : 220-240
 Frequency (Hz) : 50; 60
 Plug type : no plug
 Approval certificates : CE, VDE
 Number of cavities (2010/30/EC) : 1
 Usable volume (of cavity) - NEW (2010/30/EC) : 71
 Energy efficiency class (2010/30/EC) : A+
 Energy consumption per cycle conventional (2010/30/EC) : 0.87
 Energy consumption per cycle forced air convection (2010/30/EC) : 0.69
 Energy efficiency index (2010/30/EC) : 81.2

Optional accessories

Z11AB10A0 : Baking tray, non-stick coated , Z11GT10X3 : Glass roasting dish, 5,4l , Z11GU20X0 : Glasspan , Z11SZ00X0 : SeamlessCombination mounting kit , Z11SZ80X0 : SeamlessCombination 60 + 29cm , Z11SZ90X0 : SeamlessCombination 60 + 45cm , Z12CB10A0 : Baking tray, anthracite enamelled , Z12CM10A0 : Moussaka pan, anthracite enamelled , Z12CQ10A0 : Grill tray, anthracite enamelled , Z13TC10X0 : ComfortFlex Rail (1 level) f. steam , Z1665X0 : porcelain tray-GN1/3- unpunched , Z1685X0 : porcelain tray-GN2/3- unpunched , Z18F60X0 : Cookbook , Z1913X0 : Baking Stone



N 90, Built-in oven with steam function, Stainless steel
B47FS34H0B

Features

Design

- 4.1" TFT colour and graphics display with ShiftControl
- Illuminated Shift Control
- Cavity inner surface: Enamel anthracite
- Slide&Hide® with rotating handle

Features

- HomeConnect ready on WLAN
- Control panel lock
 - Automatic safety switch off
 - Residual heat indicator
 - Start button
 - Door contact switch
- Temperature proposal
 - Actual temperature display
 - Heating up indicator
 - Sabbath setting
- Baking and roasting assistant, Automatic programmes
- LED light
- Water tank empty indicator
- Triple glazed door

Cleaning

- EcoClean Direct : side liners, back panel, ceiling
- EcoClean programme, Base Clean programme
- De-scaling programme
- Full glass inner door

Programmes/functions

- 12 heating methods: CircoTherm®, CircoTherm® Gentle, Top/bottom heat, Conventional heat Gentle, Hot air grilling, Full surface grill, Centre surface grill, CircoTherm® intensive , Bread baking, Bottom heat, Low temperature cooking, Keep warm
- Additional heating methods with steam: Steaming, Reheat, Dough proving, Defrost
- Additional functions:
 - De-scaling programme
 - Drying function
 - Automatic boiling point detection
- Number of automatic programmes: 30 PC
- Rapid heat
- Cooling fan

Accessories

- 1-level flexible telescopic rail, full extension, Stop function
- 1 x steam container, punched, size S, 1 x steam container, punched, size XL, 1 x steam container, unpunched, size S, 1 x grid, 1 x universal pan

Performance/technical information

- Energy efficiency rating (acc. EU Nr. 65/2014): A+
 - Energy consumption per cycle in conventional mode: 0.87 kwh
 - Energy consumption per cycle in fan-forced convection mode: 0.69 kwh
 - Number of cavities: Main cavity
 - Heat source: electrical
 - Cavity volume: 71 litre
- 1 l Water tank capacity
- Location of the steam generator is outside of the cavity
- Total connected load electric: 3.45 KW
- Temperature range 40 °C - 250 °C
- Length of mains cable: 120 cm
- Nominal voltage: 220 - 240 V
- Appliance dimension (hxwxd): 595 mm x 596 mm x 548 mm
- Niche dimension (hxwxd): 585 mm - 595 mm x 560 mm - 568 mm x 550 mm
- Please refer to the dimensions provided in the installation manual

N 90, Built-in oven with steam function, Stainless steel
B47FS34HOB

Dimensioned drawings

Installation with a hob.

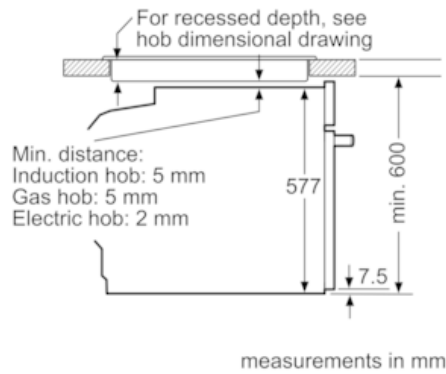

If the appliance will be installed underneath a hob, the following worktop thicknesses (including substructure if necessary) must be taken into account.

| Hob type | min. worktop thickness | |
|----------------------------|------------------------|-------|
| | fitted | flush |
| Induction hob | 37 mm | 38 mm |
| Full surface Induction hob | 47 mm | 48 mm |
| Gas hob | 30 mm | 38 mm |
| Electric hob | 27 mm | 30 mm |

