

TL 6310 INOX

Characteristics

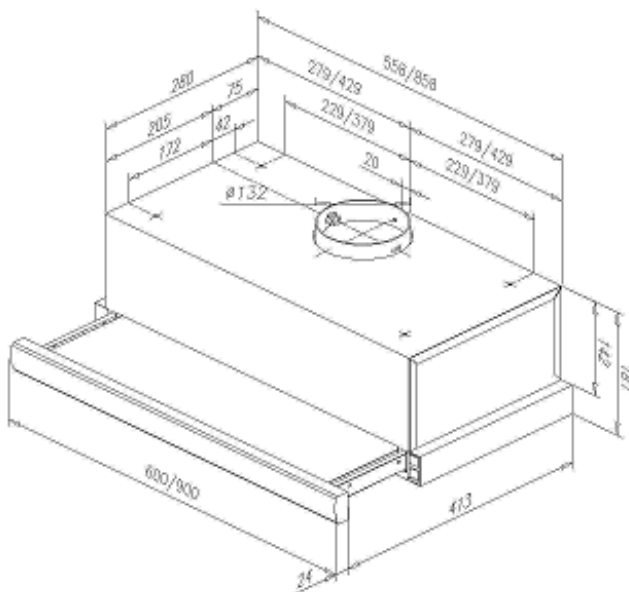

- 60cm width
- Stainless Steel
- Conventional extraction
- Switch controls
- 2 speeds
- 2x28W halogen bulbs
- Aluminum filters
- Air outlet 120mm
- European plug included
- Optional recirculation mode (C3C filter)
- Annual Energy Consumption (AEC_{hood}) kWh/a 137,5
- Energy Efficiency class E
- Fluid Dynamic Efficiency (FDE_{hood}) 6,4
- Fluid Dynamic Efficiency class F
- Light Efficiency (Lehood) lux/Watt 0,8
- Lighting Efficiency class G
- Grease Filtering Efficiency (GFE_{hood}) % 69,3
- Grease Filtering Efficiency class D
- Air flow (Qmin) m³/h 233
- Air flow (Qmax) m³/h 332
- Noise (LwA) Min Speed dB 56
- Noise (LwA) Max Speed dB 65
- Off mode Power (Po) W N/A
- Standby Power (Ps) W N/A
- Energy Efficiency Index (EEI_{hood}) 108,3
- Time increase actor (f) 1,8
- Air flow at best efficiency point (Qbep) m³/h 228
- Air pressure at best efficiency point (Pbep) Pa 149
- Electric power input at best efficiency point (Wbep) W 147
- Nominal power of the lighting system (WL) W 56
- Average illumination of the lighting system on the cooking surface (Emiddle) Lux 44