

**Serie | 6, Built-in oven, Stainless steel
HBA5570S0B**

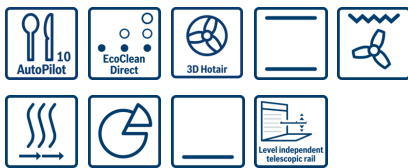

Included accessories

2 x combination grid
1 x universal pan

Optional accessories

HEZ531000 : Baking tray, grey enamelled
HEZ531010 : Baking tray, non-stick ceramic coated
HEZ538000 : 1fold telescopic rail, level independent
HEZ634000 : Baking and roasting grid (standard)
HEZ638300 : 3 level telescopic rails, full ext
HEZ915003 : Glass roasting dish, 5,4 L

**The built-in oven with AutoPilot:
automatically prepares perfect dishes.**

- **3D Hotair:** perfect results thanks to optimal distribution of heat on up to 3 levels simultaneously.
- **AutoPilot 10:** every dish is a perfect success thanks to 10 pre-set automatic programmes.
- **LCD display control, white:** easy-to-use thanks to direct access to additional functions.
- **EcoClean Direct:** almost no cleaning is necessary thanks to a special coating of the rear- and side wall and the roof that automatically absorbs grime and has a regeneration programme.
- **Level independent telescopic rail:** can be placed in any cooking level.

Technical Data

Color / Material Front :	Stainless steel
Construction type :	Built-in
Integrated Cleaning system :	Catalytic all sides
Required niche size for installation (HxWxD) :	585-595 x 560-568 x 550
Dimensions of the product (mm) :	595 x 594 x 548
Dimensions of the packed product (HxWxD) (mm) :	675 x 690 x 660
Control Panel Material :	Stainless steel
Door Material :	Glass
Net weight (kg) :	34.242
Usable volume of cavity (l) :	71
Cooking method :	Bottom heat, Conventional heat, Full width grill, Hot Air, Hotair gentle, Hot air grilling, Pizza setting
First cavity material :	Other
Temperature control :	No control of the temperature
Number of interior lights :	1
Approval certificates :	CE, VDE
Length of electrical supply cord (cm) :	120
EAN code :	4242005056613
Number of cavities (2010/30/EC) :	1
Energy efficiency class (2010/30/EC) :	A
Energy consumption per cycle conventional (2010/30/EC) :	0.97
Energy consumption per cycle forced air convection (2010/30/EC) :	0.81
Energy efficiency index (2010/30/EC) :	95.3
Electrical connection rating (W) :	2990
Current (A) :	13
Voltage (V) :	220-240
Frequency (Hz) :	60; 50
Plug type :	no plug



Serie | 6, Built-in oven, Stainless steel HBA5570S0B

**The built-in oven with AutoPilot:
automatically prepares perfect dishes.**

Design

- LCD-display control (white)
- Drop down door
- Retractable control dials, Rotary dial
- Straight bar handle
- Cavity inner surface: Enamel grey

Features

- Automatic start
Heating-up indicator
AutoPilot
- Control panel lock
Residual heat indicator
- AutoPilot10
- Electronic clock timer
- Halogen interior light
- 5 shelf positions

Cleaning

- EcoClean Direct : ceiling, back panel, side liners
- EcoClean Direct programme
- Full glass inner door

Programmes/functions

- Oven with 7 heating methods: 3D hot air, conventional top and bottom heat, Hotair grilling, full width variable grill, pizza function, bottom heat, Hotair gentle
- Fast pre-heating function

Standard accessories

- 1 set of level independent telescopic rails, Stop function
- 2 x combination grid, 1 x universal pan

Performance/technical information

- Energy efficiency rating (acc. EU Nr. 65/2014): A
Energy consumption per cycle in conventional mode: 95.3
Energy consumption per cycle in fan-forced convection mode:
0.81 kwh
Number of cavities: 1
Cavity volume: 71 litre capacity
- Temperature range 50 °C - 275 °C
- Integral cooling fan
- Length of mains cable: 120 cm
- Total connected load electric: 2.99 KW
- Nominal voltage: 220 - 240 V
- Appliance dimension (hxwxh): 595 mm x 594 mm x 548 mm
- Niche dimension (hxwxh): 585 mm - 595 mm x 560 mm - 568 mm x 550 mm
- Please refer to the dimensions provided in the installation manual

Serie | 6, Built-in oven, Stainless steel
HBA5570S0B

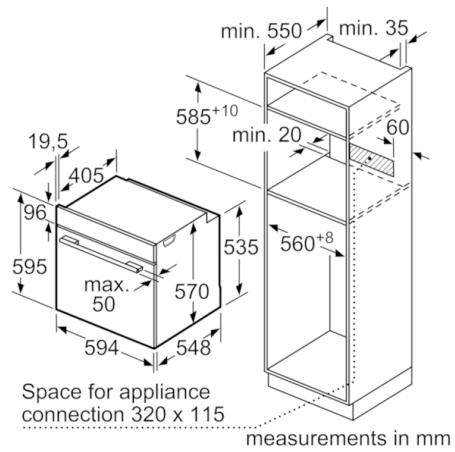
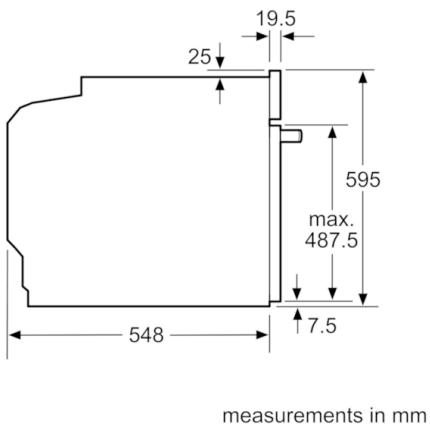

Installation with a hob.

