

MS 998 IX H

12NC: F095732

GTIN (EAN) code: 5016108957325

Hotpoint

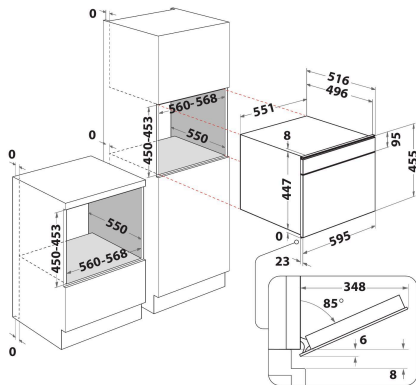

MAIN FEATURES

Product group	Oven
Commercial code	MS 998 IX H
Main colour of product	Inox
Construction type	Built-in
Type of control	Electronic
Type of control settings	LCD
Are any hobs controls integrated?	-
Which kind of hobs can be controlled?	-
Automatic programmes	Yes
Current (A)	10
Voltage (V)	230
Frequency (Hz)	50
Length of Electrical Supply Cord (cm)	125
Plug type	UK
Depth with open door 90 degree (mm)	-
Height of the product	455
Width of the product	595
Depth of the product	537
Minimum niche height	455
Minimum niche width	556
Niche depth	550
Net weight (kg)	31
Usable volume (of cavity)	29
Integrated Cleaning system	-
Grids of the cavity	1
Trays	1

TECHNICAL FEATURES

Timer	Yes
Time control	Electronic
Time-setting options	Start and Stop
Safety device	-
Interior light	Yes
Number of interior lights of the cavity	1
Position of interior lights of the cavity	-
Oven guides of the cavity	Grids
Probe of the cavity	Yes

PERFORMANCES

Energy input	-
Type of energy of the cavity	Electricity
Energy efficiency class - NEW (2010/30/EU)	A
Energy consumption per cycle conventional - NEW (2010/30/EU)	0
Energy consumption per cycle forced air convection - NEW (2010/30/EU)	0.6