

Softub®

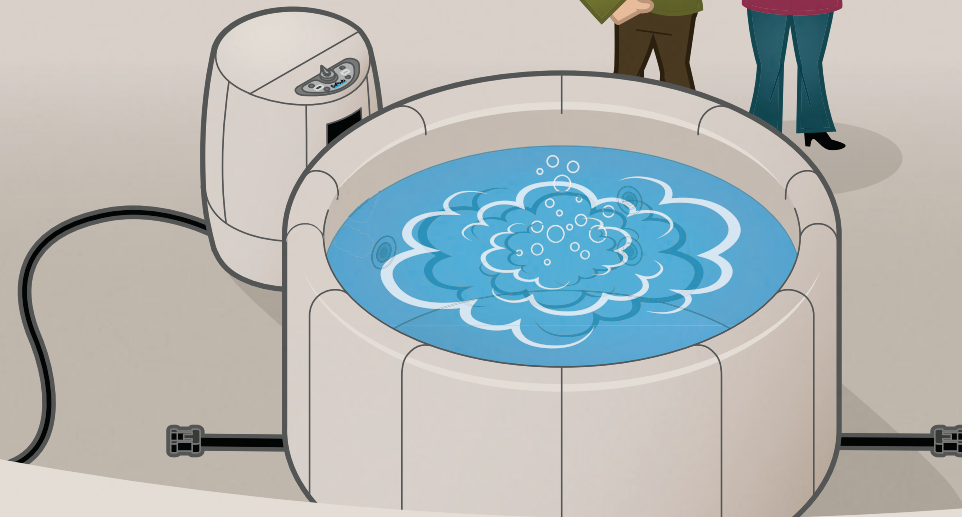

ASSEMBLY INSTRUCTIONS **INSTRUCTIONS D'ASSEMBLAGE**

140 / 220 / 300

www.softubcanada.com

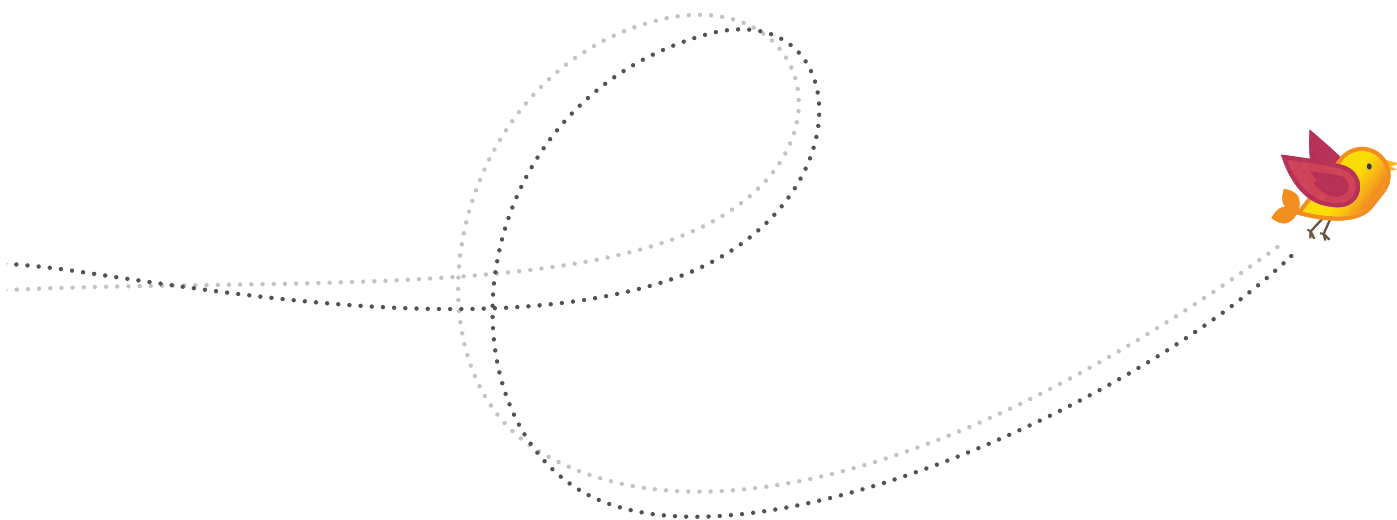



1

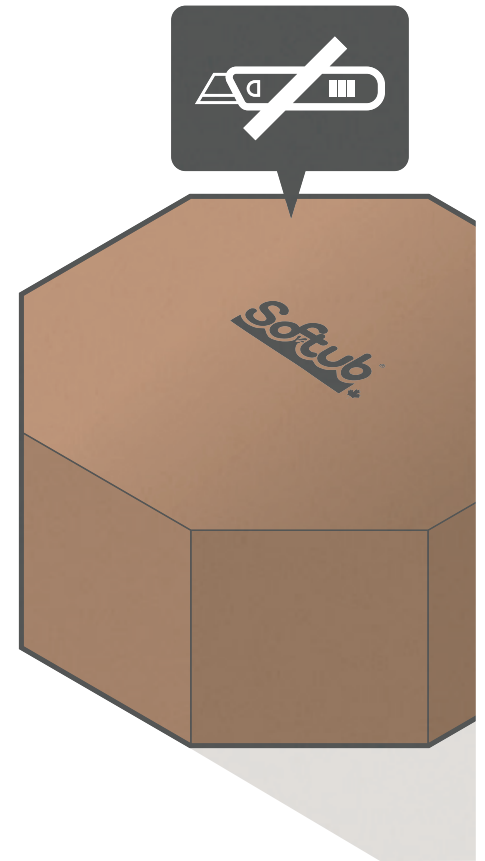
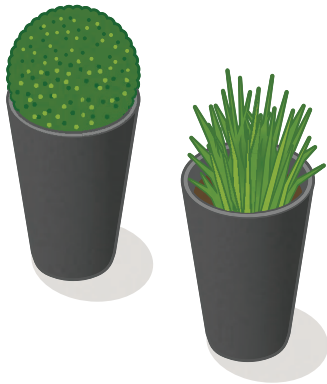

!

Roll up your sleeves and set up the Softub! Do not use a razor knife to open the box. Use the claw end of a hammer to tear the flaps open.

Roulez vos manches, il est temps d'installer votre Softub! N'utilisez pas de lame de rasoir ou couteau pour ouvrir la boîte. Utilisez le crochet d'un marteau pour ouvrir les panneaux de la boîte.

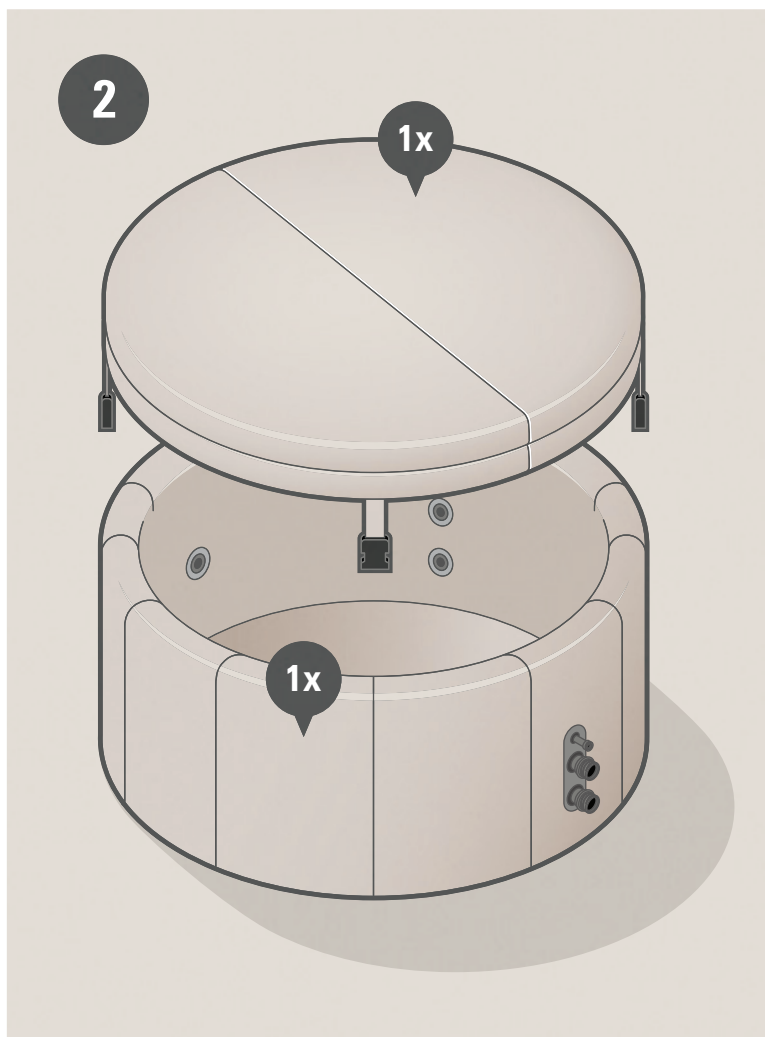

These are the items you received and will need. Please note that the filter is probably already installed in the tub. Please leave it installed on the wall of the tub.

Voici les articles reçus et dont vous aurez besoin. SVP noter que le filtre est probablement déjà installé à l'intérieur du spa. SVP le laisser installé au mur du spa.

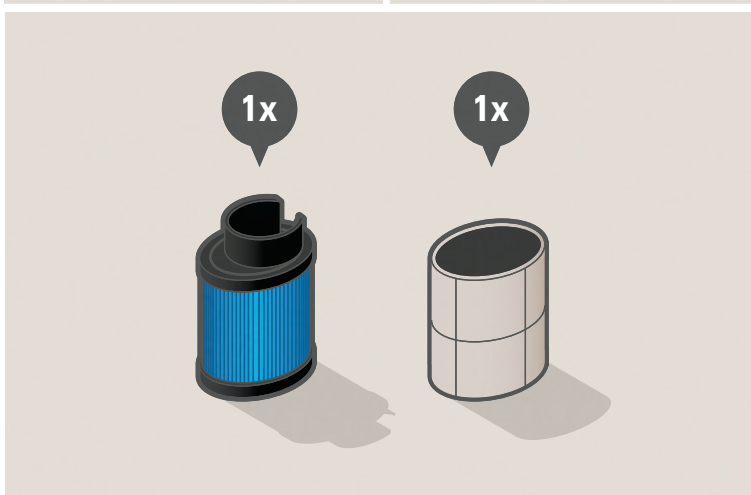
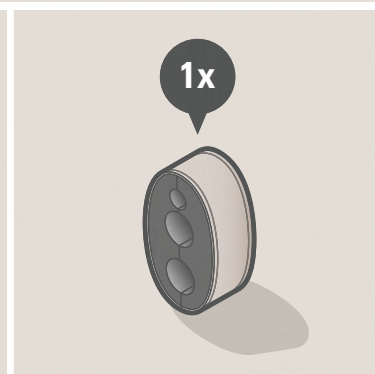
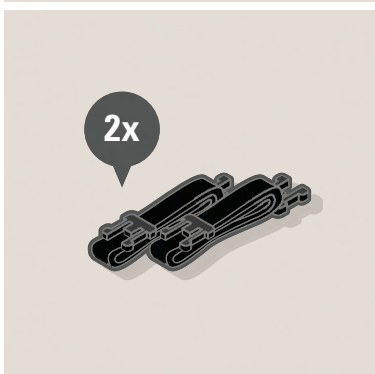

Place the straps for the cover on the ground in an "X" pattern. The back side of the buckle should be facing up so the buckle attaches properly on the lock. The plumbing connectors need to be between the straps.

Déposez au sol, en forme de X, les sangles pour le couvercle. L'arrière de chaque attache de sangle doit pointer vers le haut afin d'attacher dans la serrure à l'autre bout lorsque vous les joindrez sur le dessus du couvercle. Les connexions de plomberie doivent arriver entre les sangles.

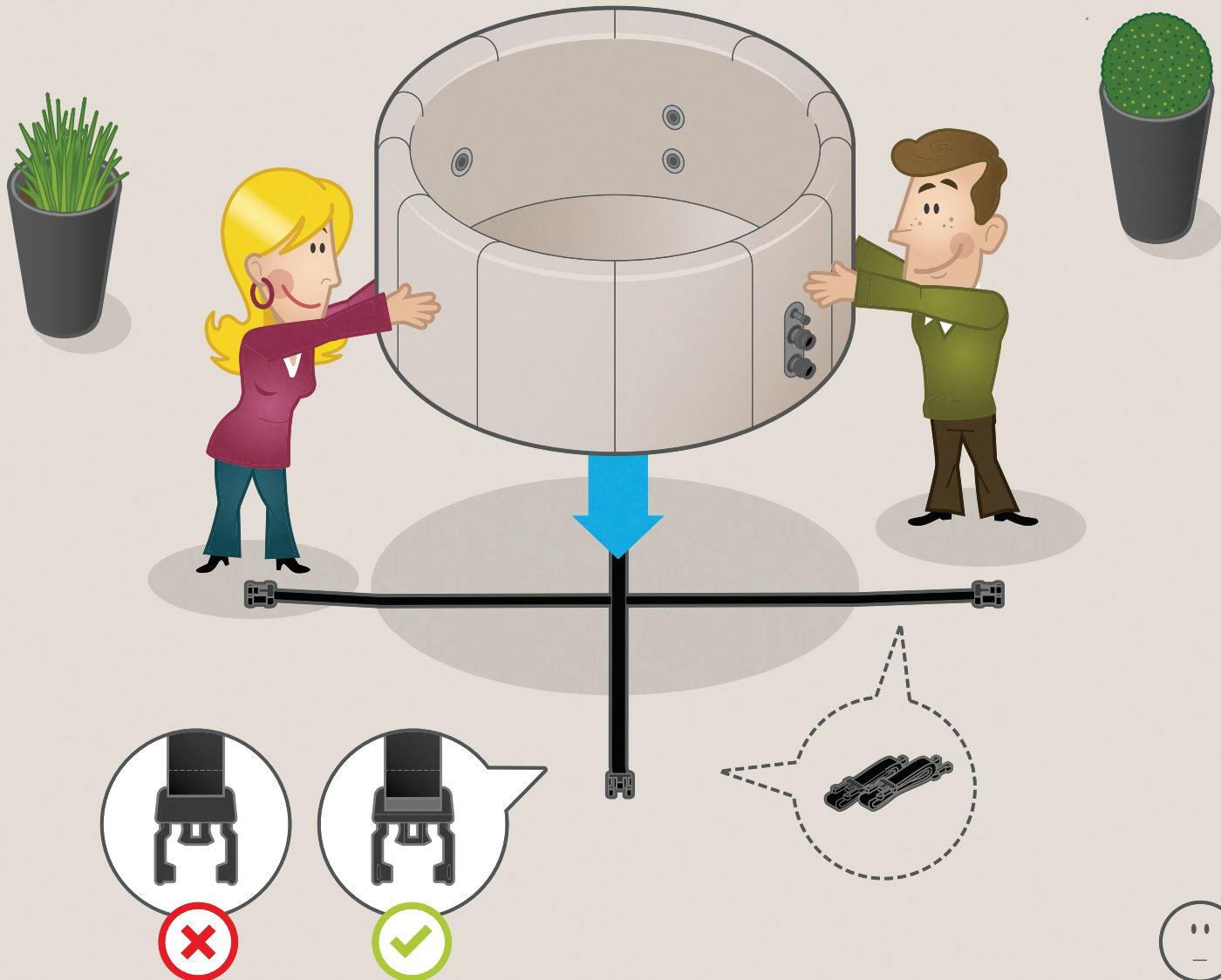

4

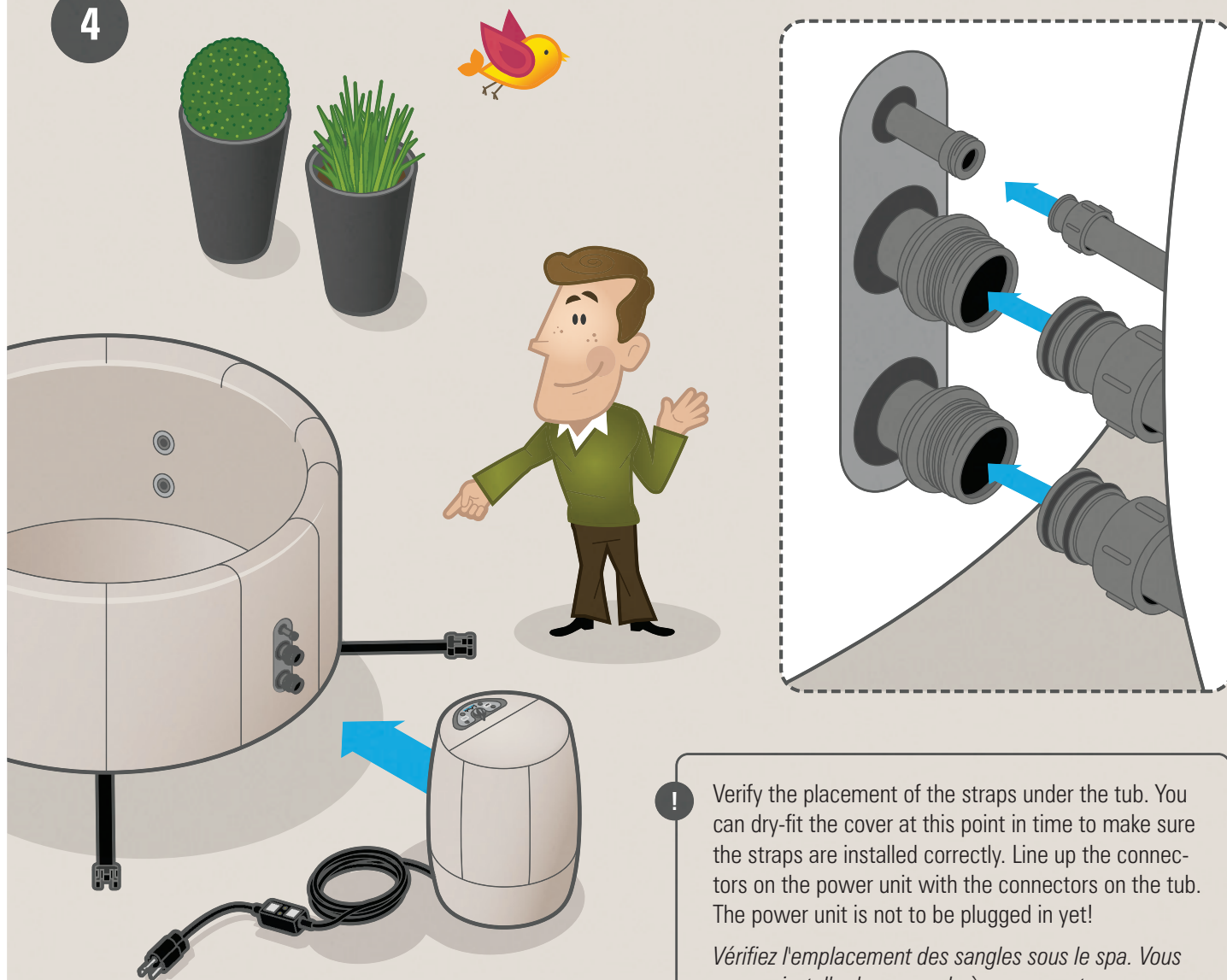

! Verify the placement of the straps under the tub. You can dry-fit the cover at this point in time to make sure the straps are installed correctly. Line up the connectors on the power unit with the connectors on the tub. The power unit is not to be plugged in yet!

Vérifiez l'emplacement des sangles sous le spa. Vous pouvez installer le couvercle à ce moment pour vous assurer que les sangles sont installées correctement. Alignez les 3 connexions de plomberie sur l'Hydromate avec les connexions équivalentes sur le spa. Guidez les connexions de l'Hydromate dans les connexions du spa. Ne branchez pas l'Hydromate à ce moment!





Twist the connectors on a clock-wise fashion until the connectors are snug and no threads are showing. Connect the light connector.

Serrez les joints de tuyaux avec vos mains en les tournant dans le sens des aiguilles d'une montre jusqu'à ce que les connecteurs soient bien serrés et qu'on ne voit plus de filetage. Assurez-vous que le joint du tuyau d'air est bien en place avant de serrer l'écrou du connecteur. Branchez le connecteur pour l'éclairage.

5

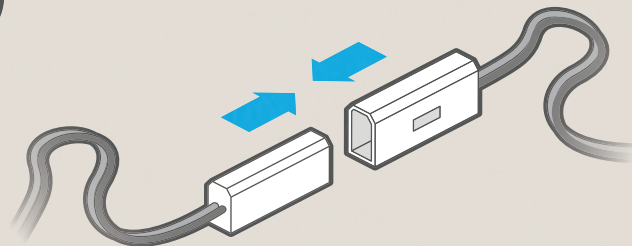
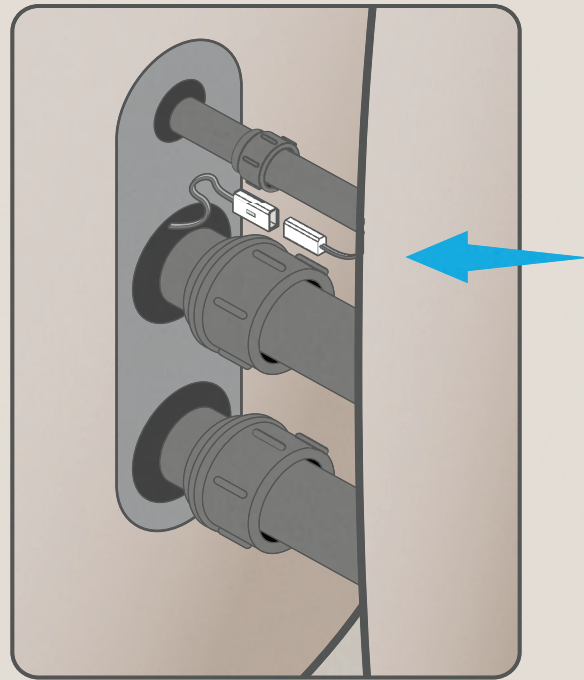
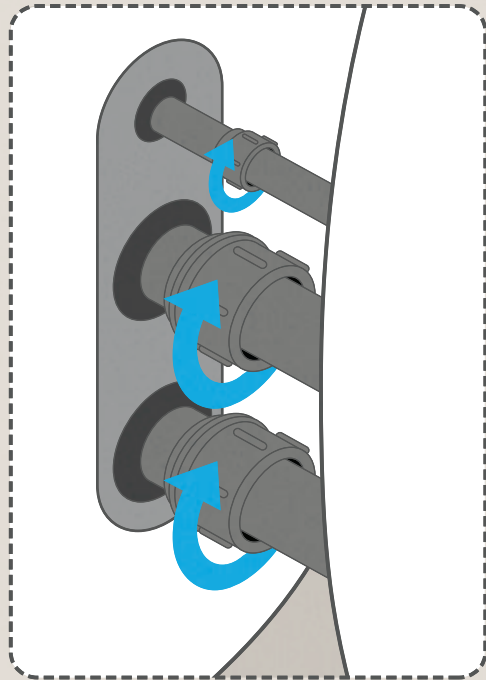

6

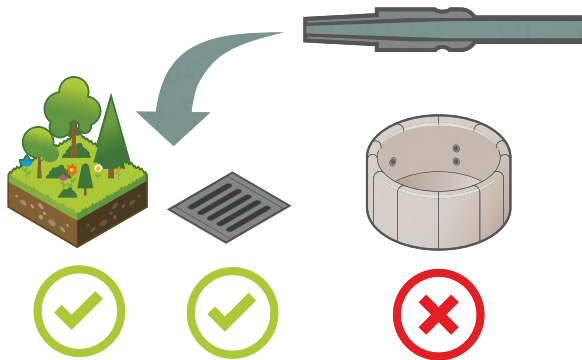

2-3 min.



!

Run the hose for 2 to 3 minutes in the garden, yard or down a drain before beginning to fill the tub. This will help to clear out any algae or debris that is in the hose. When done, begin filling the tub.

Laissez couler 2 à 3 minutes, au sol ou dans un drain, l'eau du boyau d'arrosage, avant de remplir le spa. Ceci aide à éliminer algues et débris qui sont dans le boyau. Vous pouvez commencer à remplir le spa après ce délai.

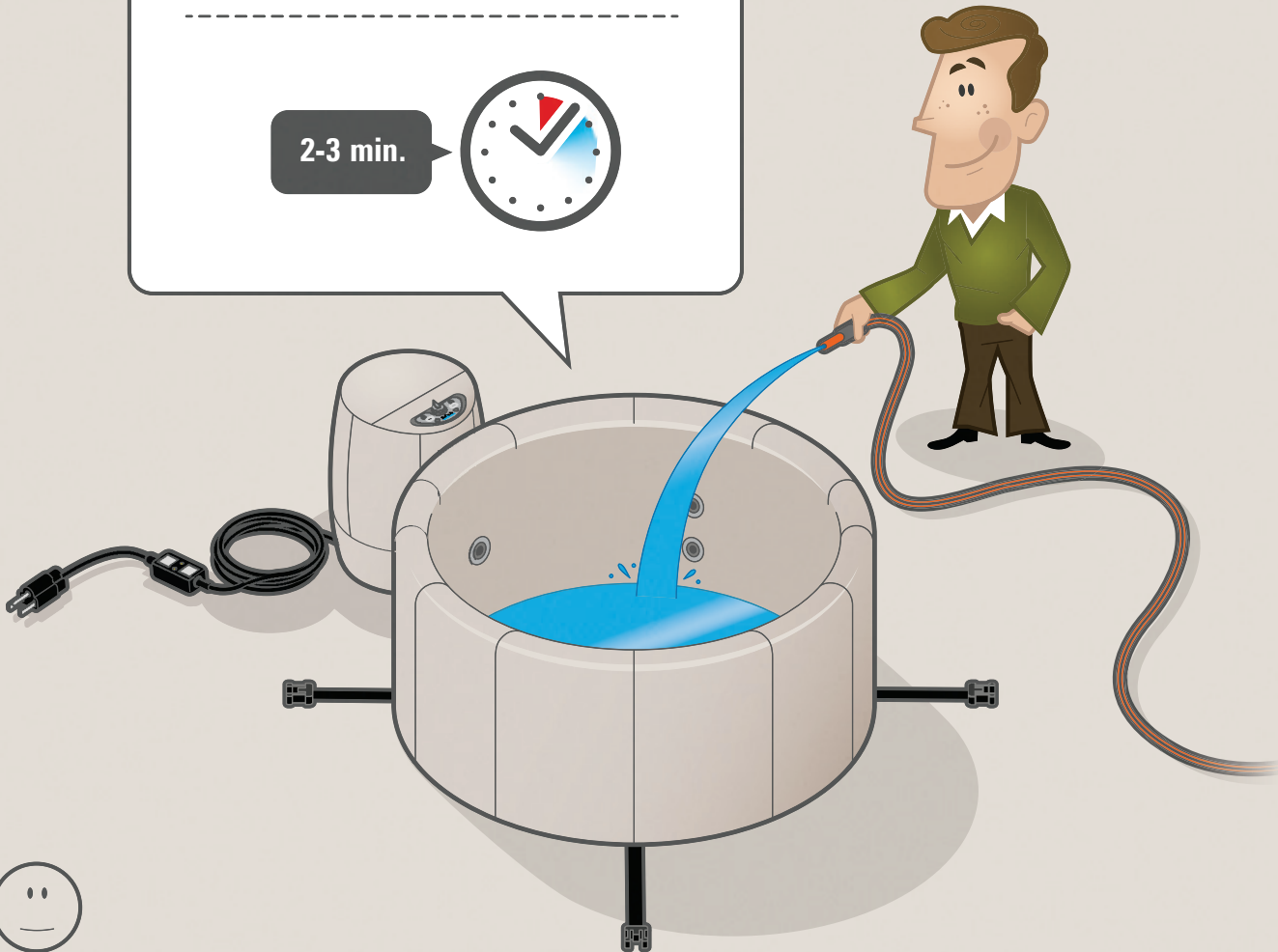

! After filling the tub with about 2 inches of water, smooth out any wrinkles on the bottom of the liner by moving the liner around with your hands and fingers. Tucking the liner in the bottom edges helps to alleviate the wrinkles.

Après avoir rempli le spa avec environ 2 pouces d'eau, utilisez vos mains et doigts afin d'étirer et étendre la toile de fond pour éliminer les plis. Insérer la toile dans les rebords du fond aide à empêcher les plis.

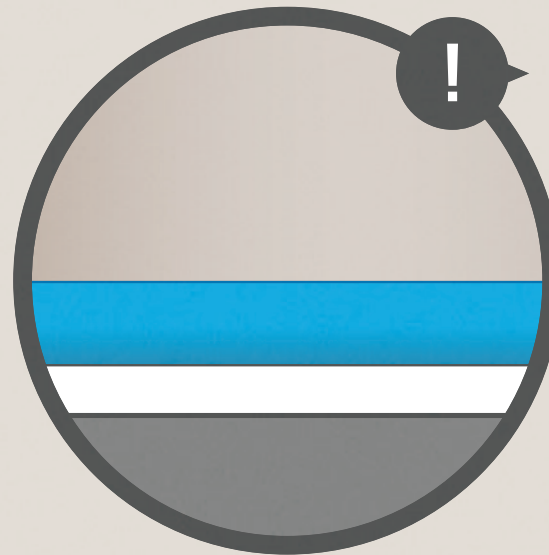
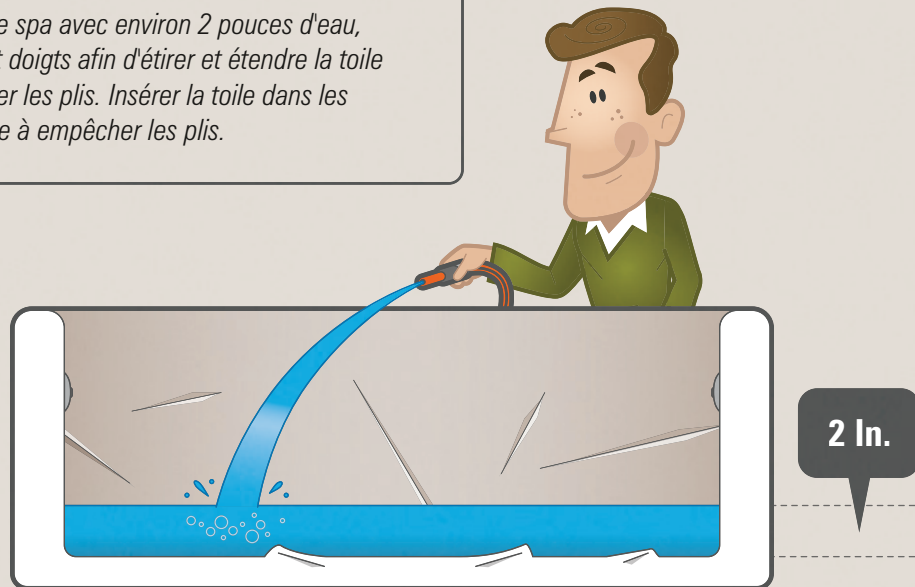

8

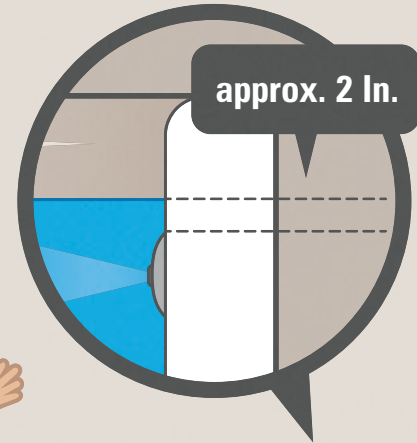
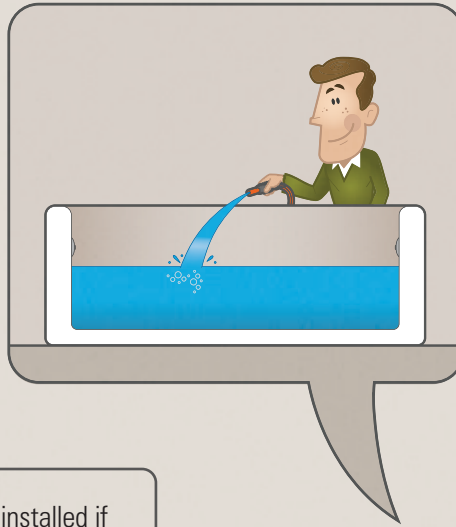

! Make sure the filter is installed if not installed already. Soak filter in warm water prior to installing to ease installation. Fill tub to a level 2 inches above the highest jet.

DO NOT PLUG IN THE TUB YET!

Assurez-vous que le capuchon est installé sur le filtre, s'il ne l'est pas déjà. Glissez le capuchon par-dessus le filtre (ajustement très serré) puis trempez le filtre dans l'eau tiède afin de faciliter son installation. Continuez de remplir le spa jusqu'à ce que l'eau soit 2 pouces au-dessus du jet le plus haut.

NE BRANCHEZ PAS LE SPA TOUT DE SUITE!

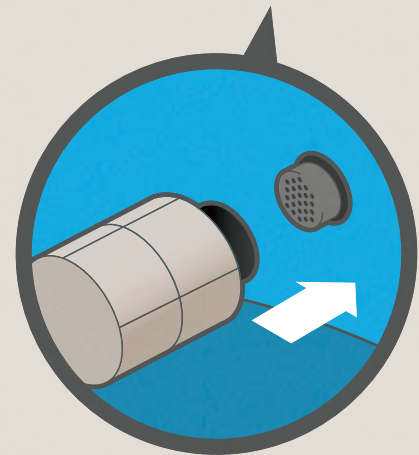
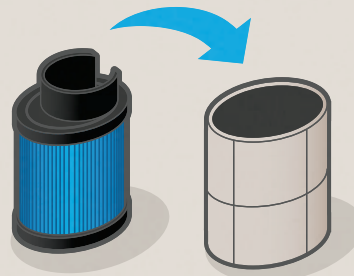
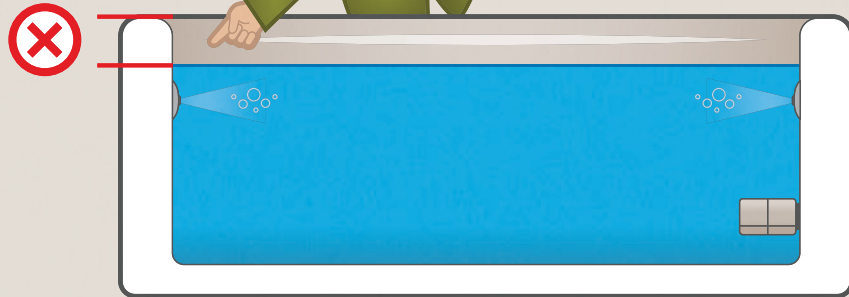

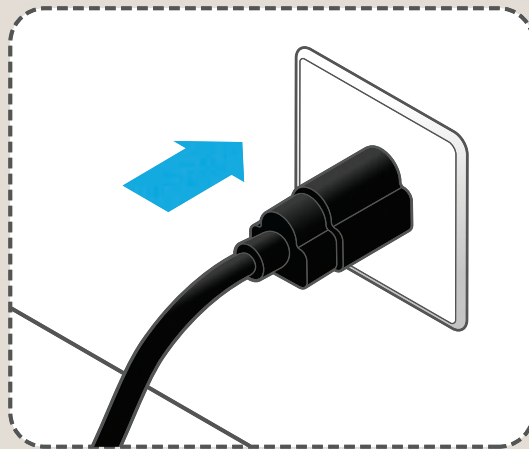
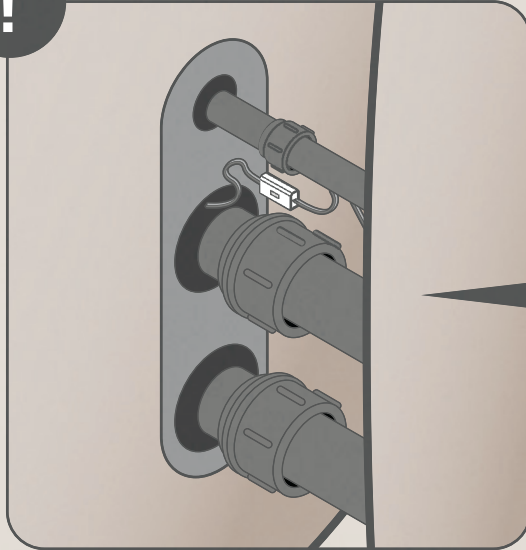

Check the tub connections for leaks. Simply tighten the connectors a little more if there is a leak. Plug the tub in now.

Vérifiez les branchements des tuyaux pour toutes fuites. Simplement resserrer les connecteurs un peu plus si ça coule. Maintenant vous pouvez brancher le spa.



10

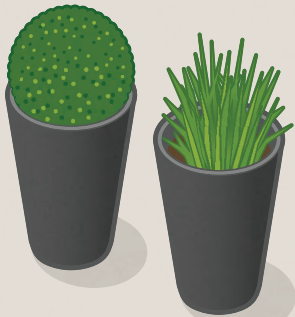

Check for leaks while the tub is running. If there are leaks, tighten the connectors. Now install the foam and vinyl connector covers.

Vérifiez pour des fuites pendant que le spa fonctionne. Si ça fuit, resserrez les connecteurs. Maintenant installez les couvre-connecteurs en mousse et en vinyle.

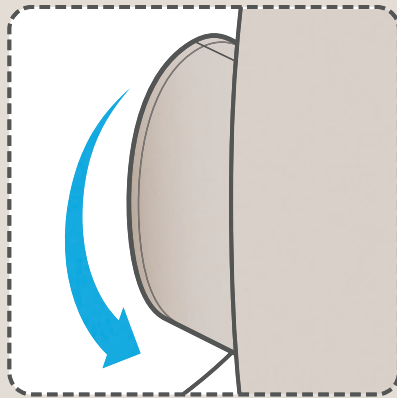
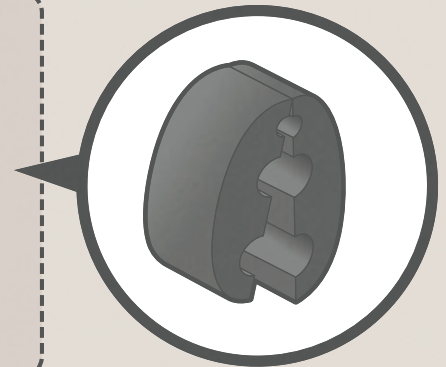
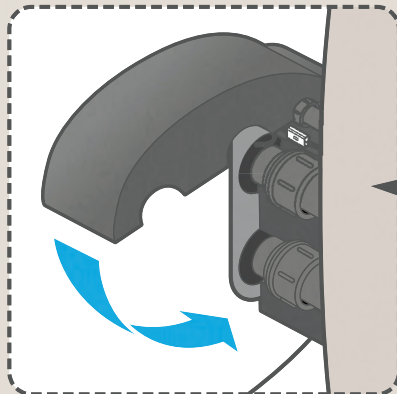
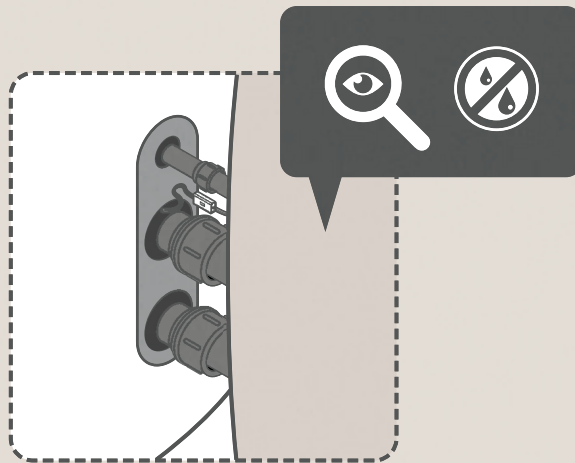

! With the tub running check the chemical levels and adjust them as necessary as advised in the Water Care Guide. Open the air control on the control panel by rotating counter-clockwise for 15 minutes after adding the chemicals. After 15 minutes, close the air control by rotating it counter-clockwise until it stops and put the lid on the tub.

Pendant que le spa fonctionne, vérifiez les niveaux chimiques et ajustez-les au besoin comme déterminé dans notre guide d'entretien de l'eau. Ouvrez le couvercle et l'entrée d'air sur le panneau de contrôle, pour 15 minutes, après avoir ajouté des produits chimiques en tournant la manette dans le sens inverse d'une montre. Après 15 minutes, fermez l'entrée d'air en tournant dans le sens des aiguilles d'une montre jusqu'à ce que ça s'arrête et refermez le couvercle du spa.

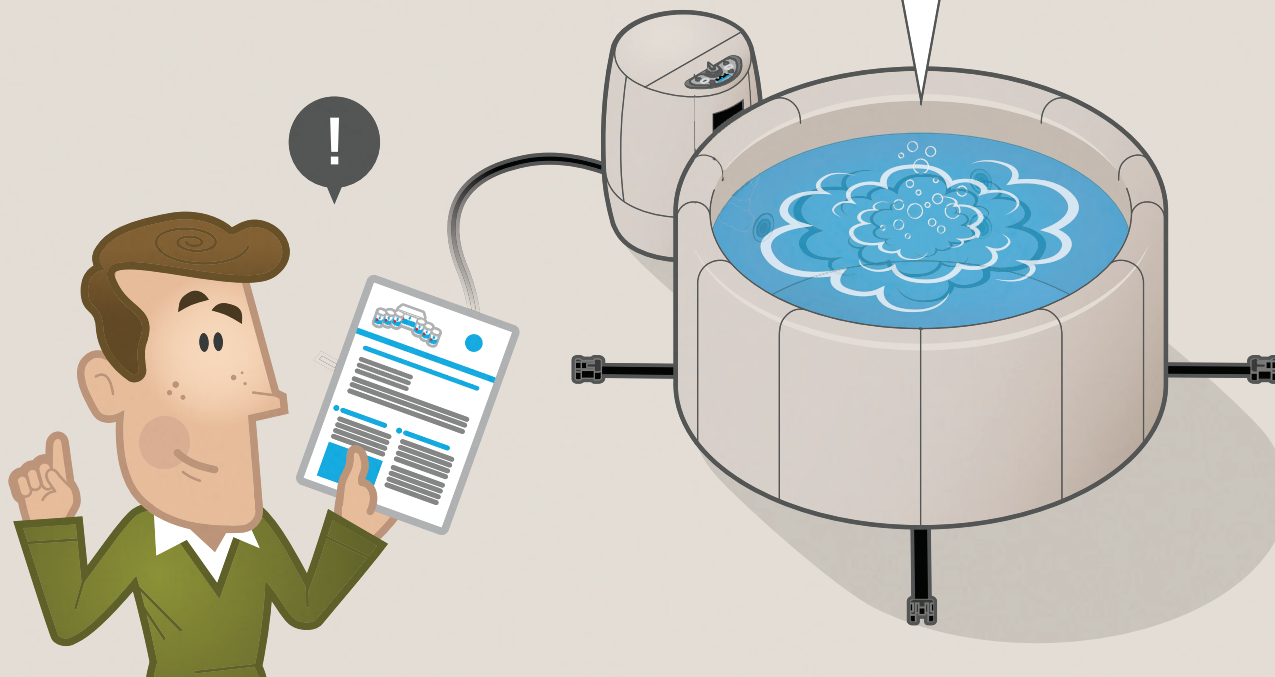
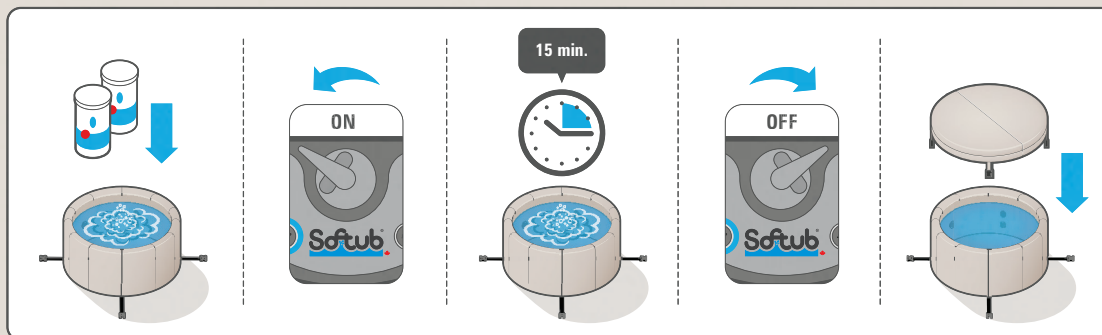

12



! Set the tub to your desired temperature and make sure to lock your cover. Your tub is now heating and will shut off when the desired temperature is reached. The tub heats at 1 to 1.5 degrees per hour.

Ajustez votre spa à la température désirée et assurez-vous de verrouiller votre couvercle en utilisant les sangles. Votre spa se réchauffera et s'arrêtera quand il aura atteint la température demandée. Le spa se réchauffe de 1 à 1,5 degrés par heure.





