



USER MANUAL

EX-G24-60C

EX-G24-80C

EX-G24-95XDP

EX-G27-100C

EX-G27-120XDP

PLEASE KEEP THIS MANUAL FOR FUTURE REFERENCE

DISCLAIMER

While every precaution has been taken to ensure the accuracy of the contents of this guide, Expion360 assumes no responsibility for errors or omissions. In addition, note that specifications and product functionality may change without notice.

IMPORTANT

Please read this manual in its entirety before using your Expion360 battery, and save it for future reference. Misuse may result in damage to the product(s) and/or cause harm or serious injury.

DESCRIPTION

Expion360 lithium batteries use lithium iron phosphate (LiFePO₄/LFP) chemistry and are designed for RV, marine, and off-grid power storage. LiFePO₄ is considered the best choice for these applications because of its high degree of safety, long life, and excellent dependability. Every battery uses cylindrical 26650, stainless steel-encased LiFePO₄ cells. The cells are UL 1642 recognized (file no. MH64383) and are certified to the highest standard in safety and performance. Internal power distribution cables are mechanically connected (bolted), rather than soldered, to lower contact resistance and provide a robust physical connection point. The internal power-distribution plates connecting the cells, battery management system (BMS), and internal terminals are solid copper. Our proprietary case contains structural elements to protect the battery pack and BMS inside from the effects of vibration and movement. The battery's oversized power terminals provide a large electrical and physical connection point to accommodate high ampacity power cables and our unique and innovative bus bars.

SERVICE CONTACT INFORMATION

Our technical support department has battery industry experts on standby to assist you, our valued customers, in every way they can. If, for any reason, you require assistance with your Expion360 battery system, contact us by phone or email any weekday during business hours and you will receive help from the best technical support in the industry.

support@expion360.com

+1 (541) 797-6714

PLEASE READ EACH WARNING CAREFULLY TO PREVENT DAMAGE AND EXTEND BATTERY LIFE

WARNINGS:

- ⚠ DO NOT DROP THE BATTERY**
- ⚠ DO NOT OPEN THE BATTERY**
- ⚠ DO NOT SHORT-CIRCUIT THE BATTERY**
- ⚠ DO NOT SUBMERGE THE BATTERY IN WATER**
- ⚠ DO NOT USE THE BATTERY AS A STARTER BATTERY**
- ⚠ DO NOT USE BATTERIES OF DIFFERENT AGES AND CAPACITIES**
- ⚠ DO NOT CONNECT MORE THAN FOUR BATTERIES IN SERIES**
- ⚠ DO NOT CONNECT MORE THAN FOUR BATTERIES IN PARALLEL**
- ⚠ DO NOT ATTEMPT TO REPAIR THE BATTERY IF MALFUNCTIONING**
- ⚠ DO NOT CHARGE THE BATTERY ABOVE 14.6 VDC**
- ⚠ DO NOT CHARGE THE BATTERY AT OR BELOW 32°F OR 0°C**
- ⚠ DO NOT CHARGE THE BATTERY ABOVE ITS MAXIMUM CHARGE RATE**
- ⚠ DO NOT DISCHARGE THE BATTERY BELOW 10.5 VDC**
- ⚠ DO NOT DISCHARGE THE BATTERY AT OR BELOW -4°F OR -20°C**
- ⚠ DO NOT DISCHARGE THE BATTERY ABOVE ITS MAXIMUM DISCHARGE RATE**
- ⚠ DO NOT LEAVE THE BATTERY CONNECTED WHEN IN STORAGE**
- ⚠ DO NOT LEAVE THE BATTERY FULLY DISCHARGED LONGER THAN 1 WEEK**

Table of Contents

1	Installation	5
2	Battery Management System (BMS)	9
3	Battery Monitoring.....	10
4	Charge	11
5	Discharge	13
6	Battery Life.....	17
7	Storage	18
8	Accessories.....	19
9	Battery Specifications	20
10	Warranty	21

1 Installation

Although our batteries can be installed in an outside battery box, be sure to confirm the battery box has drain holes to prevent water from filling the box. Unlike lead-acid, our batteries do not exhaust any harmful vapor and may be installed inside a trailer, motorcoach, truck camper, or boat cabin. Installing the batteries within an insulated or conditioned space is always recommended, especially if the batteries will ever be used in temperatures below 32°F.

The custom-molded case of our batteries includes rigid internal support structures to hold cells in place in any orientation. This allows our batteries to be installed in any position, opening up a range of creative mounting solutions our competitors are unable to accommodate. We recommend using our unique tie-down system with every installation to eliminate unwanted movement and reduce vibration. Check our website for more information on tie-down solutions for your Expion360 batteries.

When connecting multiple batteries with the Expion360 Bus Bars or power cables, tighten the M 8 x 1.25 hex bolts to 8 lb-ft (96 lb-in) using an adjustable torque wrench. Make sure all connections are bundled and well organized to prevent short circuits. Ensure all cables and circuit protection (fuses and/or circuit breakers) are properly sized for the entire system. See details about circuit protections in [Section 5.2: Circuit Protection](#).

1.1 Battery Bank Configurations

Do not mix batteries of different ages and sizes in one battery bank.
Use the Expion360 Bus Bars or 4/0 AWG cables of the same length when connecting multiple batteries.
Before installing batteries for use in series, all batteries must be parallel connected and charged to 100%.

Parallel Installation:

Connecting multiple batteries in parallel will increase the available energy (watt-hour), charge and discharge rates (current), and add capacity (amp-hour) to use your battery bank. The voltage is not increased. Up to (4) batteries may be connected in a single parallel string. To further increase the battery bank's overall capacity, additional strings may be connected to a common bus bar with equal-length cables.

Important: Any batteries wired in parallel using cables must be connected by cables of equal length and gauge (AWG).

Series Installation:

Connecting multiple batteries in series will increase the battery bank's energy capacity and voltage while maintaining the charge and discharge rates of the battery system. Note that available watt-hours will increase while the amp-hour capacity remains the value of the individual batteries and is not summed together as in the parallel configuration. Up to (4) batteries may be series-connected to achieve 24, 36, and 48 Vdc systems. To further increase the battery bank's overall capacity, additional strings may be connected to a common bus bar.

Important: Any batteries wired in series using cables must be connected by cables of equal length and gauge (AWG).

Prior to series installation, connect the batteries in parallel and fully charge to balance the batteries. For series-connected battery banks, a battery balancing device is recommended as described in 4.2 [Charging Options](#).

1.2 Installation Diagram

Battery Terminal:

The depths of the female battery terminal threads are no more than 12 mm. Consider this when determining the proper bolt length to secure bus bars, cable lugs, and any washers that will be affixed to the terminal connection pad. If too much torque is applied to a bolt, the female threads of the battery terminal will be stripped and the damage will not be covered under warranty due to misuse of the product. Consider the 12 mm thread depth when selecting your bolts so that they do not bottom-out. Conversely, a minimum of 3 threads must be engaged before applying 8 lb-ft of torque so as to not damage the threads.

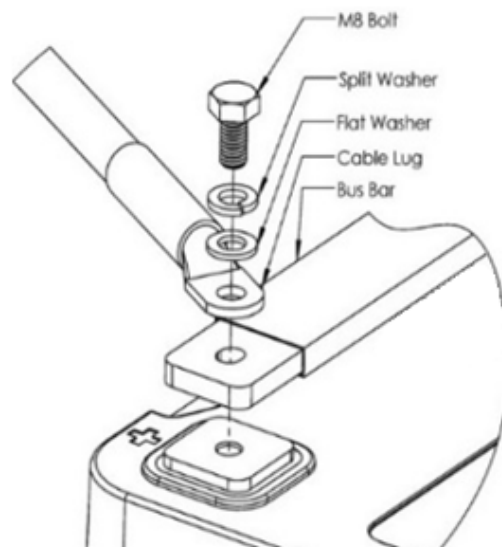

Torque to 8 lb-ft (96 lb-in).

Do not finger-tighten. Do not overtighten. Check thread depth vs. bolt length. The female thread depth of the battery terminals is 12 mm.

Battery Banks:

Parallel Connection Single String

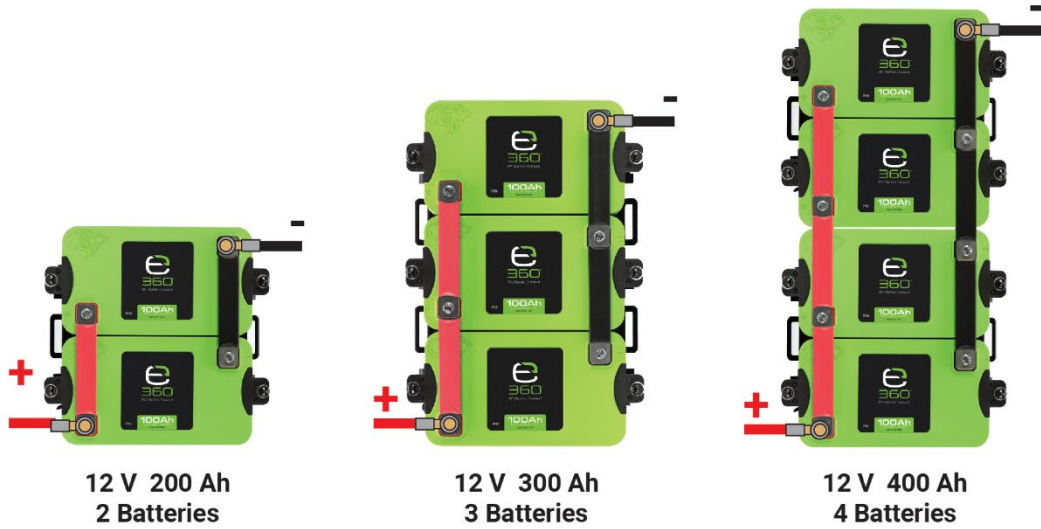

Parallel Connection Multi-string

* Cables (1) and (2) must be equal length to Common Bus Bar.

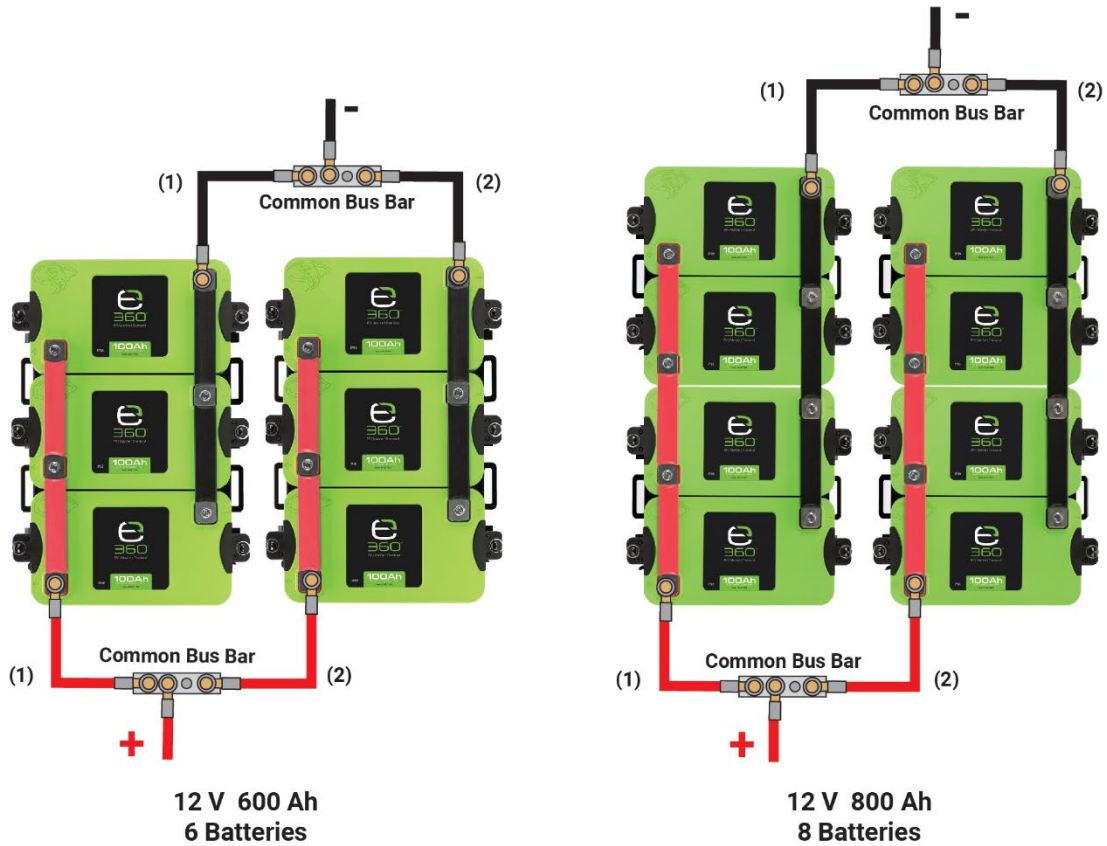

Series Connection Single String

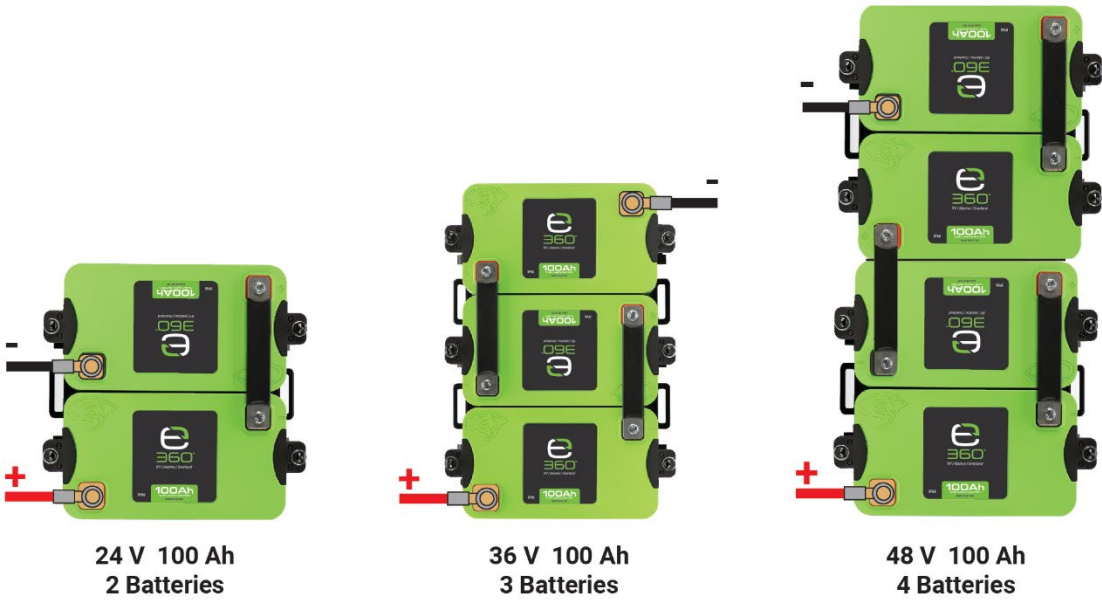

Series Connection Multi-string

* Cables (1), (2), and (3) must be equal length on each string.

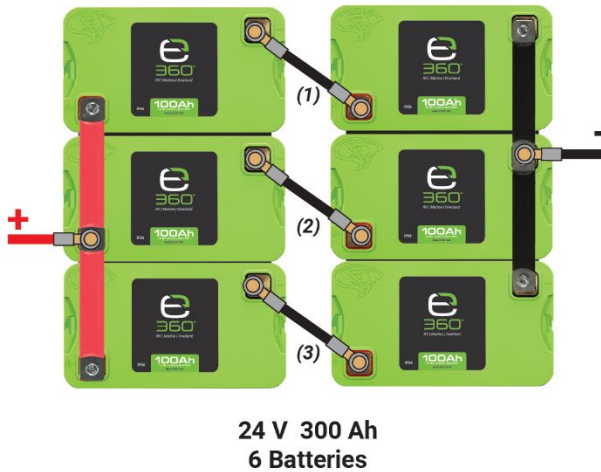

Please call technical support if your planned installation will be wired in a way not found in the provided wiring schematics.

2 Battery Management System (BMS)

See the [Battery Specifications](#) page for complete BMS protection settings.

Short Circuit Protection:

If a short circuit occurs, the BMS will disconnect to protect the battery. When the short circuit condition is corrected, the BMS will automatically reconnect. If the BMS does not reconnect, a charge is required to reset the BMS.

Overvoltage Protection:

If the charge voltage is higher than $14.6 \text{ Vdc} \pm 0.1 \text{ Vdc}$, the BMS will disconnect to protect the battery. When the battery voltage falls to $14.2 \text{ Vdc} \pm 0.2 \text{ Vdc}$, the BMS will automatically reconnect. If the BMS does not reconnect, a charge is required to reset the BMS. In some cases, it may take some time for the battery voltage to drop to 14.2 Vdc .

Undervoltage Protection:

If the battery reaches the minimum voltage of $9.5 \text{ Vdc} \pm 0.5 \text{ Vdc}$, the BMS will disconnect to protect the battery. *A charge is required within one week to prevent permanent damage and voiding the warranty of your battery.* When the battery voltage rises above $10.8 \text{ Vdc} \pm 0.4 \text{ Vdc}$, the BMS will reconnect. Some chargers will not charge if an open circuit is detected as the BMS has disconnected. We recommend using our DC-DC charger or AC-DC charger to avoid this open circuit problem and an Expion360 Battery Monitor to display voltage clearly.

Overcurrent Protection:

The BMS will monitor charge and discharge currents to protect the battery. If the charge or discharge current is too high, the BMS will disconnect to protect the battery. When a high current condition is corrected, the BMS will automatically reconnect. If the BMS does not reconnect, a charge is required to reset the BMS. See the specifications page for more details.

Thermal Protection:

If the temperature is too high or too low while charging or discharging the battery, the BMS will disconnect to protect the battery. When the temperature is within the acceptable range, the BMS will automatically reconnect.

Cell Balancing:

The BMS will monitor and prevent each of the four cell bricks from overcharging. If the individual cell brick voltages are outside the acceptable range, the BMS will automatically balance the cell bricks to bring them within range.

3 Battery Monitoring

The charge/discharge characteristic curve of a LiFePO₄ battery has a much more gradual slope than lead-acid batteries. Determining the battery's state-of-charge (SoC) based on the voltage readings is not the best practice for LiFePO₄ batteries. To accurately calculate the SoC of a LiFePO₄ battery bank, the Expion360 Battery Monitor is recommended. The battery monitor calculates the SoC based on measuring the current that passes through a finely tuned shunt resistor, rather than voltage, to give a more accurate reading of the battery bank.

The Expion360 Battery Monitor is easy to program, simple to install, and is compatible with all other brands and battery chemistries. It shows the remaining capacity (Ah), SoC (%), battery bank voltage (V), charge/discharge current (A), and charge/discharge power (W). The battery monitor also shows the remaining discharge time until empty and the remaining charge time until full. Include this useful accessory for peace of mind, and to see your battery metrics at any time without manually probing your batteries.

Note that the voltage displayed on the Battery Monitor will read higher or lower than the actual value if the battery has been charged or discharged within an hour of measurement. Precision will increase with time until 12 hours have passed, after which the measured voltage will not change. This is not a design flaw, but an inherent characteristic of all batteries as they are charged and discharged. A greater difference in voltage will be measured when the battery is disconnected from high current sources/loads than low current sources/loads.

4 Charge

The optimal and maximum charge rates of a battery bank are equal to the rates of a single battery multiplied by the number of batteries connected in parallel. To prolong the useful life of your batteries, the optimal charge rate (0.2C) is recommended. The battery bank can be charged at the maximum charge rate (0.5C) for rapid power recovery if the temperature conditions listed in the [Battery Specifications](#) section are met. Never charge the battery bank above the maximum charge rate. See the [Battery Specifications](#) for each battery's optimal and maximum charge rates for different temperature conditions.

Example:

A battery bank has (4) 100 Ah batteries connected in parallel. The maximum charge rate of a single Expion360 battery is 50 A at 0.5C. The capacity of the battery bank is 400 Ah. The maximum charge rate of the battery bank is 200 A (0.5C). This method also applies to the optimal charge current.

If a battery or battery bank has been discharged to zero SoC, you must recharge the battery within a week to prevent battery damage and voiding warranty.

4.1 Charger Profile

Two-Stage CC-CV Charger:

Chargers using a constant current (CC) constant voltage (CV) profile are ideal to charge LiFePO₄ chemistry batteries. We recommend charging Expion360 batteries with a target voltage range from 14.2 Vdc to 14.6 Vdc, although 14.4 Vdc is preferred.

The CC (bulk or boost) stage charges the battery to 95% SoC at the charger's rated current until the battery reaches the charger's voltage setting. The charger then transitions to the CV (absorption or saturation) stage at the charger's given voltage setting and tapers the charge current down to zero as the battery reaches the charger's target voltage. The CV stage usually takes about 10 minutes, depending on the charger and the capacity of the battery.

The charger then enters standby mode and will charge the battery if a lower battery voltage is detected.

Single-Stage CC Charger:

A single CC stage charger can charge the battery to nearly 100% SoC. Single-stage CC chargers with target voltage settings from 14.2 Vdc to 14.6 Vdc (14.4 Vdc preferred) may also be used to charge Expion360 batteries, however, a CC-CV charger is advised.

Multi-Stage Charger:

A multi-stage (CC, CV, float, equalization) charger is primarily designed for flooded, AGM, and gel lead-acid batteries, and is not an ideal selection for LiFePO₄ batteries. The multi-stage charger slows down the charging process and may not fill the battery to 100% SoC. Expion360 batteries do not require a float stage because of their low self-discharge rates. LiFePO₄ batteries do not require an equalization stage because they do not experience damaging sulfation when left at states of charge lower than 100% for long periods. The charge voltage may also rise above 14.6 Vdc during the equalization stage, which would cause the BMS to disconnect due to overvoltage protection.

4.2 Charging Options

Shore Power Charging:

Expion360 batteries should be charged by a CC-CV two-stage charger with voltage settings from 14.2 Vdc to 14.6 Vdc. The rated charge current should never exceed the maximum charge rate of the battery bank. See [Battery Specifications](#) for individual charge currents for each model.

Our batteries may be configured as an uninterruptible power supply (UPS) with an inverter charger. Inverter chargers need to be programmed before a connection is made to shore power. On the inverter charger controller, under the "Battery Type" menu, choose the "CC-CV" setting in the setup, and set the charge voltage to 14.4 Vdc. The "Custom" setting on some inverter chargers is not recommended. The additional settings are determined by the design of the power system and different inverter chargers. Please refer to the inverter charger manual or contact Expion360 support for more information.

Solar Charging:

Expion360 batteries can be charged from solar power using a solar charge controller. A maximum power-point tracking (MPPT) charge controller is recommended as it has higher efficiency than a pulse-width modulation (PWM) charge controller.

Choose a solar charge controller that can be programmed for two-stage charging or one with a lithium battery setting. If using a programmable solar charge controller, set the charge voltage from 14.2 Vdc to 14.6 Vdc (14.4 Vdc preferred).

To prevent the solar charge controller from charging the battery bank below 32°F, install a disconnect switch between the solar panels and the solar charge controller. Make sure the switch is sized to handle the voltage and maximum current of the solar array. Some solar charge controllers have a temperature sensor and can be programmed to stop charging at a specific temperature. It is advised to set this temperature to 32°F. Please refer to the solar charge controller manual or contact the Expion360 support department for more assistance.

Alternator Charging:

The Expion360 battery can be charged from an alternator using any DC/DC charger equipped with settings for LiFePO₄ batteries. The Expion360 DC/DC charger is a CC-CV two-stage charger that is designed only to charge LiFePO₄ batteries with a 25 A output current. The Expion360 DC/DC charger is simple to install and compatible with any other LiFePO₄ battery. Within the limits of the battery bank and alternator specifications, up to two Expion360 DC/DC chargers can be used in parallel to achieve a higher charge rate.

Battery Balancer:

For series-connected battery banks of 24, 36, or 48 Vdc, an external battery balancer is recommended to maintain the balance of charge between all series-connected batteries.

5 Discharge

The Expion360 battery is designed for deep cycle use only. It should **NEVER** be used in a starting application. The maximum continuous discharge rate of the battery bank is equal to the maximum continuous discharge rate of a single battery multiplied by the number of batteries connected in parallel. Never discharge the battery bank above its maximum continuous discharge rate. See the Battery Specifications page ([Section 9](#)) for the optimal, maximum, and pulse discharge rates of each Expion360 battery.

For example, a battery bank has four 100 Ah Expion360 batteries connected in parallel. The maximum continuous discharge rate of a single Expion360 battery is 100 A (1C). The capacity of the battery bank is 400 Ah. The maximum continuous discharge rate of the battery bank is 400 A (1C). The same method applies to the recommended optimal discharge current and maximum pulse discharge current.

5.1 Inverter

The maximum continuous DC current must be considered carefully when pairing a battery bank with an inverter. The inverter cannot have a higher maximum DC input than the battery bank's maximum DC output. Otherwise, the BMS in the battery may shut off due to discharge overcurrent protection. An oversized inverter may irreversibly damage the battery bank in a worst-case scenario. The example below shows minimum battery bank capacities for various sizes of 12 Vdc inverters with estimated discharge times at full load.

Battery size (Ah)	60	80	95	100	120	360
-------------------	----	----	----	-----	-----	-----

1000 Watt Inverter

1 Battery				1h 3m	1h 16m	2h 38m
2 Batteries	1h 16m	1h 41m	2h 0m	2h 6m	2h 31m	5h 15m
3 Batteries	1h 53m	2h 31m	3h 0m	3h 9m	3h 47m	7h 53m
4 Batteries	2h 31m	3h 22m	4h 0m	4h 12m	5h 2m	10h 30m

2000 Watt Inverter

1 Battery						1h 19m
2 Batteries				1h 3m	1h 16m	2h 38m
3 Batteries		1h 15m	1h 30m	1h 35m	1h 53m	3h 56m
4 Batteries	1h 15m	1h 40m	2h	2h 6m	2h 31m	5h 15m

3000 Watt Inverter

1 Battery						
2 Batteries						1h 45m
3 Batteries				1h 3m	1h 15m	2h 38m
4 Batteries		1h 7m	1h 20m	1h 24m	1h 40m	3h 30m

Properly size the battery bank's capacity to the inverter to prevent battery damage.

Match the battery bank's maximum pulse and continuous discharge current to the inverter's maximum surge and input current, respectively.

Use only inverters that have been certified to conform to UL 458.

For more information about pairing inverters and battery banks with capacities that are not listed above or further details about 24 Vdc, 36 Vdc, and 48 Vdc systems, please contact Expion360 technical support:

Support@expion360.com

+1 (541)797-6714

5.2 Circuit Protection

Properly sized circuit protection must consider the battery bank's maximum DC output, the inverter's maximum DC input, the size, length, and rating of the cables being used. The fuse or circuit breaker must be able to withstand the maximum continuous current that can be supplied by the battery bank and must be located as close to the battery bank as is safely possible. Use Blue Sea Systems fuses provided in the table below or an equivalent by an approved manufacturer.

Fuse Rating	Class T Fuse P/N	ANL Fuse P/N
60 A	N/A	5123
80 A	N/A	5124
100 A	N/A	5125
110 A	5112	N/A
125 A	5113	N/A
150 A	5114	5127
175 A	5115	5128
200 A	5116	5129
225 A	5117	N/A
250 A	5118	5131
300 A	5119	5133
350 A	5120	5135
400 A	5121	5136
500 A	N/A	5137
600 A	N/A	5161
750 A	N/A	5163

For Class T fuses between 110 to 200 A, use Blue Sea Systems fuse holder 5007100

For Class T fuses between 225 to 400 A, use Blue Sea Systems fuse holder 5502100

For ANL fuses between 60 to 200 A, use Blue Sea Systems fuse holder 5005

For ANL fuses between 225 to 750 A, use Blue Sea Systems fuse holder 5503

Class T fuses are recommended to protect the power system due to their lower voltage drop and higher efficiency. For the budget-conscious consumer and lower current applications, ANL fuses are sufficient (at the cost of reduced system efficiency). Use fuse and breakers from the following approved manufacturers to protect against overcurrent events and ensure the safety of your Expion360 battery system: Blue Sea Systems, Littelfuse, Eaton, or Bussman.

Single String Battery Bank:

For small battery banks that have fewer than four batteries or have a single string configuration, circuit protection (fuse or circuit breaker) should be installed close to the battery bank's positive terminal before connecting to the load. The fuse rating is based on the maximum continuous discharge rate of the battery bank. For example, if the maximum continuous discharge rate of a 400 Ah battery bank is 400 A, this battery bank should be paired with a 400 A DC fuse. In this example, any wires connecting the battery bank to the inverter must also be properly sized for a 400 A continuous current.

Multi-string Battery Bank:

For large battery banks that have more than 4 batteries, or have multiple strings configurations, the circuit protection (fuses or circuit breakers) should be installed close to the battery bank's positive terminal of each string before connecting to the common bus bar. The fuse rating is based on the maximum continuous discharge rate of each string of the battery bank. For instance, if the maximum continuous discharge rate of two strings of parallel-connected batteries is 800 A with 400 Ah on each string, the battery bank should be paired with a 400 A DC fuse on each string. The cables connecting the two strings to the inverter must be sized properly for the maximum 800 A current.

For more information about correctly sizing circuit protection for the battery power system, please contact an authorized installer or Expion360 technical support:

Support@expion360.com

+1 (541)797-6714

6 Battery Life

The battery is considered to reach the end-of-life (EoL) when the remaining available capacity is less than 80% of the original capacity. The cycle life of Expion360 batteries is tested at a charge/discharge rate of 0.2C/1C, 77°F, and 100% depth-of-discharge (DoD). Please note that many factors can affect battery cycle life. Using the recommended charge and discharge rates will offer longer life to your batteries.

DoD:

The cycle life of our G24 and G27 batteries is tested by discharging the batteries to a 100% DoD. The optimal window for operating LFP batteries is a DoD between 20% and 80%. To accommodate this, slightly over-size the capacity of the battery bank so that the DoD is about 80% for each cycle. This is beneficial to the batteries and will help to prolong the battery life. For example, in a 12 Vdc system, if 200 Ah is required for each cycle, the battery bank is recommended to have a 240 Ah capacity.

Operating Temperature Range:

Operating LFP batteries at extremely low or high temperatures will significantly decrease their cycle life. Please make sure the battery bank is well ventilated, or cooled during high temperatures and kept heated at low temperatures. Maximum battery life can be achieved when operating temperatures are as close to 77°F as possible. We advise installing our heating blankets ([Section 8](#)) with your batteries to protect them from extreme cold and to keep them close to ideal temperatures.

Charge/Discharge Rate:

Charging and discharging the battery at higher than recommended rates will generate more heat within the cells. Since temperature is the primary factor that affects the cycle life, consider the charge/discharge specifications with regards given to ambient temperature extremes when configuring your battery power system. The specifications page at the end of this manual considers both safety and the maximum life cycle when recommending optimal parameters for the battery system.

Storage Condition:

Most users will see their batteries in storage more often than active daily use. To prolong the battery life during periods of storage of one month or longer, please give careful consideration to the following instructions in [Section 7](#).

7 Storage

Properly storing the battery bank between 20% and 80% state-of-charge (SoC) will prolong the battery life and using a battery monitor to assist with tracking the SoC is highly recommended. If a battery monitor is not available, measure the battery voltage with a voltmeter (set to DC). If the battery is found to be less than 13.3 Vdc, charge it, and store the battery at 13.4 Vdc. Note that the battery voltage will read low or high if it has been discharged or charged within an hour of measurement. Precision will increase with time until 3 hours have passed, after which the voltage measurement will not change.

Before storing, the battery bank needs to be completely isolated from any loads (DC load, inverter, etc.) and charging sources (converter charger, solar charger, etc.). The Expion360 Battery Monitor can be left on the battery bank to check the status of the battery bank. Charge the battery bank to full capacity and recalibrate the battery monitor, before using the battery bank after the storage.

Please follow the guidelines below for lengths of storage time. Check the battery storage conditions in [Section 7](#) for more details.

1 month:	13.4 Vdc, -4°F to 113°F.
3 months:	13.4 Vdc, -4°F to 95°F.
6 months:	13.4 Vdc, -4°F to 77°F.

Completely discharge and charge the battery bank to 13.4 Vdc every 6 months.

Due to the inherent self-discharge of all batteries, it is advised to check the voltage displayed on the battery monitor periodically. If at any time the voltage is below 12 Vdc, check the battery bank and make sure it is completely disconnected from any load. Charge the battery bank to 13.4 Vdc and disconnect the charger. Isolating the batteries from the charger and load ensures that no parasitic draws may still be applied due to design flaws of third party accessories.

WHEN BATTERIES ARE PLACED IN STORAGE FOR LONGER THAN 2 to 4 WEEKS...

Charge the battery bank to 50% state-of-charge or an open circuit voltage of about 13.4 Vdc and disconnect all positive and negative cables from the battery terminals to prevent parasitic loads and irreversible battery damage.

IF BATTERIES ARE DISCHARGED TO 0% SoC...

Immediately charge the battery bank to 13.4 Vdc and confirm that all positive and negative cables have been disconnected from the battery terminals. All batteries using LiFePO₄ chemistry will be permanently damaged if discharged to 0% SoC and left for over **one week**. This is not a design flaw but is an inherent characteristic among all lithium iron phosphate batteries. The industry-leading 12-year Expion360 warranty excludes coverage for such damages due to neglect of the batteries by the end-user.

8 Accessories

The products listed below are compatible with Expion360 G24 and G27 batteries.

Model EV-BM350: Battery monitor with display and complete installation kit.

Model EX-25DC: Expion360 DC to DC 25 A, 14.6 Vdc, 2-stage charger.

Model EX-24-TDS: Single battery tie-down system to secure the battery to an RV or boat floor.

Model EX-24-2-TDS: Dual battery tie-down system. For four batteries use two dual trays.

Model EX-24-3-TDS: Triple battery tie-down system. For six batteries use two triple trays.

Model EX-27-TDS: Single battery tie-down system for group 27 battery.

Model EX-27-2-TDS: Dual battery tie-down system for group 27 battery.

Model EX-27-3-TDS: Triple battery tie-down system for group 27 battery.

EX-G24_27-BUS: Aluminum bus bar (highly economic and efficient to connect batteries).

EX-G24-TJ-KIT & EX-G27-TJ-KIT: Heating blanket kits for low-temperature use.

EX-2000WIC & EX-3000WIC: Expion360 pure sine wave inverter chargers, 2000 W and 3000 W.

For questions regarding these products, feel free to contact Expion360 technical support:

Support@expion360.com

+1 (541)797-6714

9 Battery Specifications

	Specifications	EX-G24-60C	EX-G24-80C	EX-G24-95XDP	EX-G27-100C	EX-G27-120XDP	
Electrical	Battery Nominal Voltage	12.8 Vdc					
	Battery Rated Capacity (@ 0.2C, 77 °F)	60 Ah	80 Ah	95 Ah	100 Ah	120 Ah	
	Battery Rated Energy (@ 0.2C, 77 °F)	768 Wh	1024 Wh	1216 Wh	1280 Wh	1536 Wh	
	Battery Internal Impedance (@ 1kHz AC, 50 % SoC)	≤80 mΩ	≤60 mΩ	≤60 mΩ	≤50 mΩ	≤50 mΩ	
	Battery Self-discharge Rate (@ 77 °F, 100 % SoC)	<2 – 3 % per month					
	Battery Cycle Life (@ 0.2C / 1C, 77 °F, 100 % DoD) (80 % Capacity retention)	>4000		>3500	>4000	>3500	
	Max. Series Connection (per string)	4					
Mechanical	Battery Size	G24			G27		
	Battery Dimensions (Length x Width x Height)	10.24 in x 6.81 in x 8.59 in (260 mm x 173 mm x 218 mm)			11.93 in x 6.81 in x 8.59 in (303 mm x 173 mm x 218 mm)		
	Battery Weight	19 lbs. (8.7 kg)	24 lbs. (10.9 kg)	25 lbs. (11.4 kg)	29 lbs. (13.3 kg)	30 lbs. (14.0 kg)	
	Case Material	Fiberglass Infused ABS					
	Terminal Material	Brass					
	Terminal Thread	M 8 x 1.25 (12 mm ∇)					
	Torque Spec	8 lb-ft (10 Nm)					
	Cell Type	Cylindrical LiFePO ₄					
Charge	Charge Method	CC-CV					
	Charge Voltage	14.2 Vdc to 14.6 Vdc					
	Optimal Charging Target Voltage	13.8 Vdc (about 80 % SoC)					
	Optimal Charge Current (0.2C)						
	Quick Charge Current	32 °F to 50 °F (0 °C to 10 °C) (0.2C)	12 A	16 A	19 A	20 A	24 A
		50 °F to 140 °F (10 °C to 60 °C) (0.5C)	30 A	40 A	48 A	50 A	60 A
	Overcharge Disconnect	14.6 Vdc ± 0.1 Vdc					
	Overcharge Reconnect	14.2 Vdc ± 0.2 Vdc					
Charge Temperature Range	32 °F ± 9 °F to 140 °F ± 9 °F (0 °C ± 5 °C to 60 °C ± 5 °C)						
Discharge	Optimal Discharge Current (0.5C)	30 A	40 A	48 A	50 A	60 A	
	Max. Cont. Discharge Current (1C)	60 A	80 A	95 A	100 A	120 A	
	Max. Pulse Discharge Current (3 s)	80 A	100 A	120 A	120 A	150 A	
	Optimal Shut-off Voltage	12.4 Vdc (about 20 % SoC)					
	Overdischarge Disconnect	9.5 Vdc ± 0.5 Vdc					
	Overdischarge Reconnect	10.8 Vdc ± 0.4 Vdc					
Discharge Temperature Range	-4 °F ± 9 °F to 140 °F ± 9 °F (-20 °C ± 5 °C to 60 °C ± 5 °C)						
Storage	Recommended Storage Voltage	13.4 Vdc (about 80 % SoC)					
	1 month	-4 °F to 113 °F (-20 °C to 45 °C)					
	3 months	-4 °F to 95 °F (-20 °C to 35 °C)					
	6 months	-4 °F to 77 °F (-20 °C to 25 °C) Discharge-Recharge Cycle every 6 months					

10 Warranty

Online product registration is required for warranty coverage.

For current warranty information please check our website:

<http://www.expion360.com>

