



**Demand the best. Demand Dynamic.**

PROJECT

ITEM NUMBER

QUANTITY



**MINIPRO**



**REFERENCE**

- MX070.1 (115V)
- MX070 (230V)

**DESCRIPTION**

THE LEAST EXPENSIVE COMMERCIAL HAND HELD MIXER IN THE WORLD. QUICK AND EFFICIENT, THE DYNAMIC MINIPRO IS IDEAL FOR ALL LIGHTWEIGHT MIXING.

**FEATURES**

- 200 WATTS
- 13000 RPM
- 6.5" STAINLESS STEEL FOOT
- 2.5 LBS
- VARIABLE SPEED
- TITANIUM PLATED CUTTER BLADE
- GOOD FOR UP TO 1 GALLON / 4 LITRES OF MIXING
- 1 YEAR PARTS AND LABOR WARRANTY

**MINI SERIES**

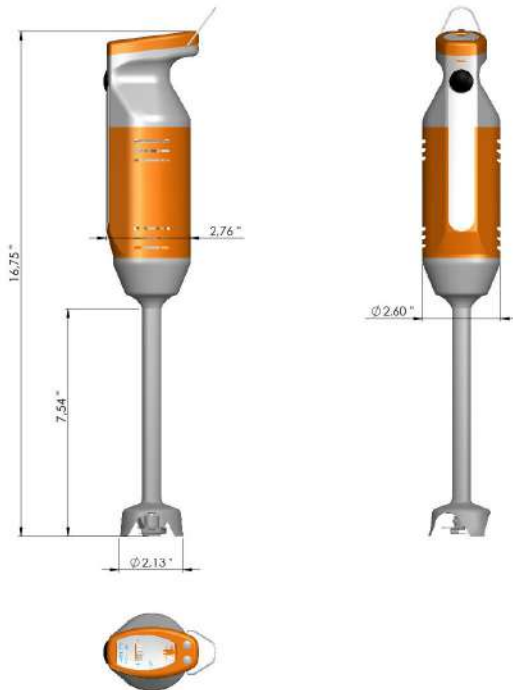

**SHIPPING INFORMATION**

- SHIPPING WEIGHT: 3.2 LBS
- SHIPPING BOX DIMENSIONS
- LENGTH: 5.25" (133.35MM)
- WIDTH: 4.5" (114.30MM)
- HEIGHT: 18.25" (463.55MM)
- CUBIC MEASURE: 0.25FT<sup>3</sup> (0.007M<sup>3</sup>)

**IMMERSION BLENDERS**

**WARRANTY POLICY**

Dynamic will guarantee all new Dynamic products to be free from defects in materials & workmanship. Electric products - Includes a 1 year parts and labor carry in bench warranty; with the exception of component replacements necessary through regular "wear & tear". Manual products include a 1 year limited parts warranty. Warranty is valid, providing the products have been used in accordance with Dynamic's operating recommendations & guidelines. Dynamic or any authorized service center will repair or replace, at our discretion and after examination, any or all manufacturer's defective parts during the warranty period. Any damage caused by improper use, abuse, dropping, or similar accidental damage resulting in breakage will render the warranty null and void. During the warranty period, only Dynamic or one of its authorized service centers may perform evaluations or repairs to products. Warranty will be void on any equipment which has been dismantled or tampered with during this warranty period if this has been done by unauthorized centers or personnel.

