



**PROFILE
DESIGN**

1/50 RIM BRAKE CLINCHER WHEELSETS

VERSION 01-10-12-2020

INTRODUCTION

Thank you for purchasing this Profile Design Wheelset. These instructions apply to the 24mm wide, 50mm deep 1/50 Clincher rims.

Please read these instructions thoroughly before attempting to install this item. Proper installation is required for compliance with Profile Design's warranty policy. If you are not familiar with installing wheels or their accessories, please seek the assistance of your local Profile design dealer by logging on to www.profile-design.com and using "dealer search" or by calling Profile Design's customer service number p.# 888.800.5999.

Note to Dealers: If you install this product for the consumer, please provide him/her with this owner's manual after installation.

Tools and materials required:

- Cassette Tool
- Tire Levers
- Floor pump with pressure gauge
- Clean, lint free cloth

Your Wheelset should contain:

- Valve extender/bladed spoke tool
- Tire levers (3)
- Rim Strip(s)
- 10 Speed Cassette spacer– only included with rear wheels or wheelsets (as these wheels are designed for SRAM, Shimano and 11 speed cassettes)
- Front and/or rear wheel “quick release” skewers (nut, skewer and attached cam lever)
- Profile Design carbon rim specific brake pads (does not include pad holder or mounting hardware. These brake pads are specific for Shimano/SRAM mounting hardware.)

If anything is missing from the wheelset please contact your dealer.

IMPORTANT SAFETY INFORMATION AND WARNINGS

Before each ride check to ensure:

- Each quick release is properly adjusted, closed and the wheel is properly seated and aligned in each dropout so that brakes and shifting work properly.
- Brakes are properly functioning and adjusted.
- Wheel is “true” (does not wobble from side to side or “hop” up and down when rotated on the bike) and rotates freely.
- Spokes/nipples are not damaged, bent or of improper tension. (check by applying finger tension to all spokes and comparing tension between them)
- There is no visible damage to the carbon surfaces of the rim or brake track.
- Tires (proper size) are properly inflated and evenly mounted and have no surface cuts, abrasions, bulges, cracking or other irregularities.
- If the wheelset fails any of these checks **DO NOT** use the wheel.

PART DRAWINGS

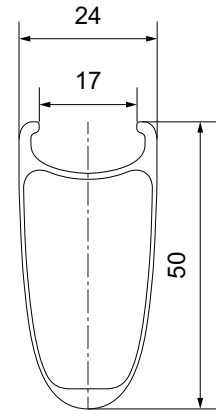

1/FIFTY

COMPONENT LIST

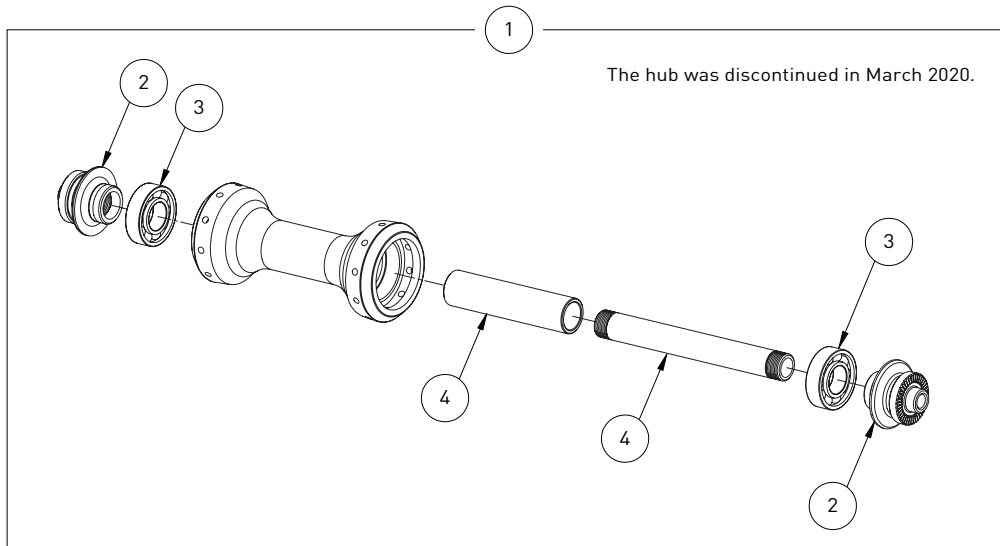

N	PN	Component	N	PN	Component
1	Discontinued	Full Front Hub	3	HA00055	Front Hub Bearing(6900)
2	Discontinued	Front Hub End Cap	4	Discontinued	Front Hub Axle

COMPONENT LIST

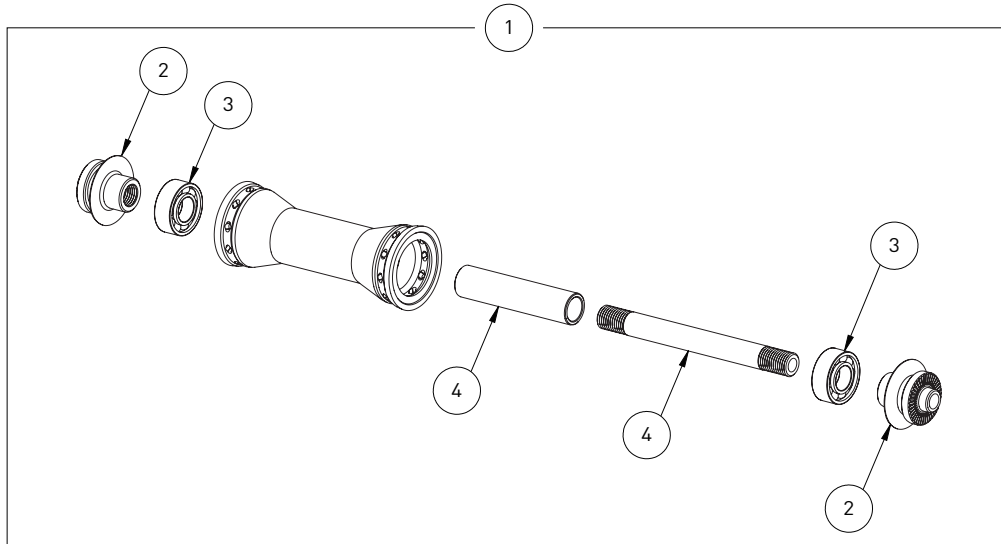

N	PN	Component	N	PN	Component
1	860148	Full Front Hub	3	860216	Front Hub Bearing(699)
2	860215	Front Hub End Cap	4	860217	Front Hub Axle

COMPONENT LIST

Hub model : QL-8N4PR

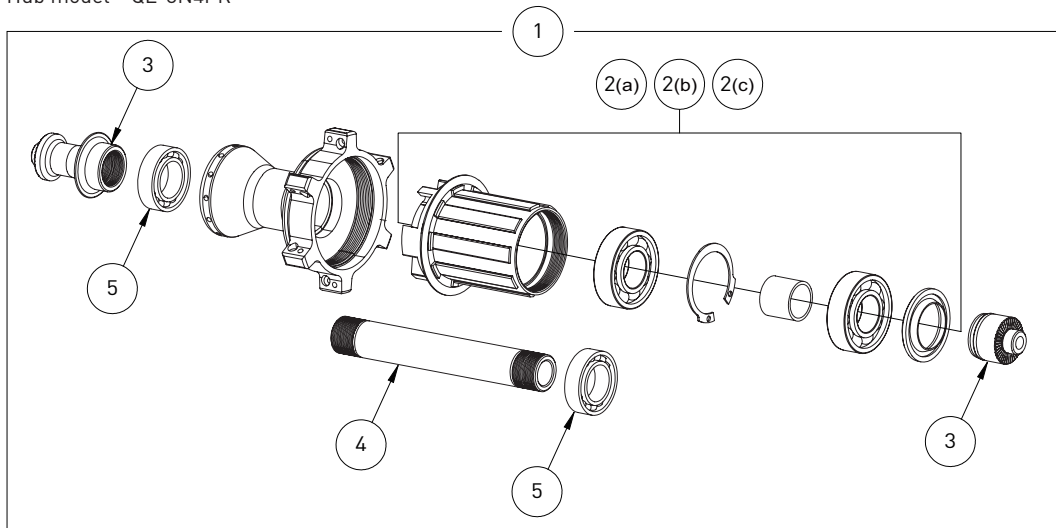

N	PN	Component	N	PN	Component
1	860149	Full Rear Hub	3	860166	Rear Hub End Cap set
2(a)	860142	10/11s Sram/Shimano Freehub	4	860218	Rear Hub Axle
2(b)	860134	10/11s Campy Freehub	5	860219	Rear Hub Bearing(6802)
2(c)	860165	12s Sram XDR Freehub			

SPOKE LENGTH

Wheel		Spoke Length
1/FIFTY	Front	259mm
	Rear drive side	268mm
	Rear non-drive side	263mm

PRODUCT SPECIFIC SETUP LIMITATIONS

Recommended Tire Size	700C x 23-35mm
Recommended Inflation pressure (also refer to Tire sidewall)	70-100 PSI
Recommended Use	Road/Triathlon/Time Trial

Only clincher or tubeless clincher tires can be used with these wheels.
Carbon specific brake pads must be used with these wheels.

INSTALLATION INSTRUCTIONS

Install Rim Strip(s)

1. Ensure that the rim bed is clean and free of debris.
2. Carefully stretch the rim strip around the rim.
 - a. make sure that the strip is centred on the rim and is covering the spoke holes.

Installing Clincher Tires

1. Place the wheel, valve hole up, with the wheel resting against your legs and mount one side of the tire bead onto the rim using your hands.
2. Take note if your tire has directional arrows and also install the tire with the manufacturer's label/PSI rating at the valve hole – this will assist with finding flats and will make for easier inflation reference later.
3. Work the tire onto the rim by moving your hands away from the valve hole on each side of the wheel as you seat the tire bead.
4. If the last section of tire bead will not seat by hand VERY CAREFULLY use a PLASTIC tire lever to seat the last section of tire onto the wheel.
5. Inflate the inner tube enough that it will hold its shape.
6. Insert the valve of the tube through the valve hole of the rim making sure the valve is straight.
7. Then install the rest of the tube between the rim and tire. Make sure that the tube is not folded, twisted or creased once placed inside the tire.
8. Tubes are also sold in different diameters and widths. Make sure the tube size is closely matched with the tire size you are using. Use of the wrong size tube could lead to bunching or stretching of the tube and a blow out resulting in a crash and injuries.

9. Install the second bead of the tire onto the rim working the tire onto the rim by moving your hands away from the valve hole on each side of the wheel as you seat the tire bead.
10. If the last section of tire bead will not seat by hand VERY CAREFULLY use a PLASTIC tire lever to seat the last section of tire onto the wheel. Be careful that you do not pinch the inner tube with the tire lever or tire bead as you seat this last section. Make sure the tube is not under the bead of the tire anywhere on either side as this will burst the tube once you inflate it.
11. Inflate the tire to 40-60 PSI and check to make sure the tire is seated correctly and that the inner tube is not pinched between the tire and the rim. Deflate the tube and re-install the tire should there be any problems.
12. Inflate the tire to full pressure and check the tire as it is rotating to make sure the tire is seated straight on the rim. Also check the bead line (usually a small rib on the tire just a few millimetres above the rim edge) of the tire to insure that the bead is seated evenly and uniformly all the way around the rim on both sides.
13. **DO NOT EXCEED 125 PSI** for **ANY** Profile Design clincher rim regardless of the pressure listed on the tire.

FIT THE CASSETTE

1. Make sure you have the correct cassette for your free hub, speed and manufacturer.
2. Slide the Cassette on to the freehub.
 - a. If using a 10 speed cassette, first install the supplied 1.65mm spacer.
 - b. The spacer is not required for 11 speed cassettes.
3. Thread on the lockring by hand to ensure proper thread engagement.
4. Using a torque wrench, tighten the lockring to 50Nm. (check Torque)

INSTALL QUICK RELEASE SKEWERS

1. Remove the locknut and spring from the skewer.
2. Insert the skewer through the hub.
3. Place the spring (narrow end first) on the skewer and thread on the locknut.

FIT WHEELS TO BIKE

1. Ensure the brake calipers are open.
2. Rest the fork tips or frame dropouts on the hub axle.
3. If it is difficult to do this check.
 - a. Quick release is open.
 - b. Centring springs are correctly oriented.
 - c. Locknut is not threaded on too far.
4. Close the quick release, it should require firm pressure to do this.
 - a. If the lever is too loose, open it and tighten the locknut then try again.
 - b. If the lever is too tight, open it and loosen the locknut then try again.
 - c. Repeat until you have a lever tension that requires the heel of your hand to close and two fingers to open.
5. Orient the lever so it is not against the frame or fork as this will make it difficult to open when needed.
6. Close the brake calipers.
7. Spin the wheel to check that it is centred in the brake calipers.
8. Pull on the brakes to ensure there is sufficient force –the end of the brake lever should travel 20-30mm (1") before contacting the rotor.

WHEEL MAINTENANCE

TRUING WHEELS

1. TRUING YOUR WHEELS ALL REPAIRS OR TRUING SHOULD BE PERFORMED BY A PROFESSIONAL BICYCLE WHEEL MECHANIC.
2. The technique and skill required to properly true a wheel is well beyond the scope of these instructions and beyond the ability of most riders.
3. Your wheels have been carefully pre-stressed, tensioned and trued before shipping and should remain true and round under normal riding conditions.
4. Ensure that your wheels do not have a vertical "hop" or side to side "wobble" once you remove them from the box (by spinning them in your dropouts without tires). They may have been damaged in shipping. Over time or under abnormal riding conditions you may need to re-true and re-tension your wheels for optimal performance. (Typically wheel truing needs to be done after 1000-2000 miles of riding).
5. If you are not sure how to properly perform this service or do not have a spoke tensiometer or wheel truing stand with run out gauges, please take your wheel to a professional bicycle mechanic, or contact Profile Design at www.Profile-Design.com for more details.

CLEANING YOUR WHEELS

1. Remove and clean the wheel quick releases regularly and check the tightness of the tension nut and cam lever.
2. Clean your wheel using mild soap and water only.
3. DO NOT pressure wash or spray with water. Pressure washers can force the grease out the hub bearings which causes rapid deterioration of the bearings and the longevity of the hubs.
4. Be sure to remove any dirt, grime, grit, grease or lubricant that might get onto the brake surface of the wheel.
5. Make sure your brake pads are clean and free from aluminum shavings, small rocks and other debris accumulated from riding.
6. Clean your brake pads with fine sandpaper or a small file. Proper care and cleaning of your new Profile Design wheels and brake pads will extend the life of the wheels and help to protect the braking surface.
7. Do not use harsh chemical cleaners on the rims or braking surfaces.

INSPECTING YOUR WHEELS

1. Cleaning or mounting a tire is a good time to inspect your wheels closely under good lighting conditions.
2. Look for any abnormal bumps or bulges, areas where the clearcoat is worn, any sign of frayed carbon fibers, cracks, deformities, or holes.
3. This inspection needs to be carried out on a regular basis but especially.
 - a. after any crash or after you have hit road debris or potholes.
 - b. when tires are removed.
 - c. before a race.
 - d. after shipping or flying with the bike .
 - e. when the tires have gone flat while riding.
 - f. when the wheels make any unusual noises such as clicking, squeaking, cracking or snapping noises.

TRAVELING WITH YOUR WHEELS

1. If you ship (or fly with) your bike and/or wheels, the wheels should be transported in their own carrying cases to prevent damage.
2. We suggest heavily padded single wheel bags or a hard case.
3. After shipping or flying, the wheels must be inspected (see "Inspecting your wheels") and possibly re-trued (see "Truing your wheels") as flying or shipping wheels often will damage them or cause them to go out of true.

WARRANTY

- Profile Design Worldwide Two Year Limited Warranty.
- Profile Design, LLC (distributor) warrants to the original retail purchaser (“you”) that the Profile Design product for which you received this warranty is free from defects in material and workmanship for (2) two years from the date of original retail purchase.

For more details on this warranty, its exclusions and/or how to make a claim under the warranty please call +1 310.747.0085 extension 161 or visit www.profile-design.com/pages/warranty



2677 El Presidio Street

Long Beach, CA 90810

Ph: 310-884-7756

www.profile-design.com

© Profile Design LLC