



QUICK CHANGE ARM ASSEMBLY INSTRUCTIONS

BRODBECK IRONWORKS LLC





REVISION B

Contact Brodbeck Ironworks LLC for any questions or concerns before operating this equipment

IF YOU HAVE ANY ISSUES WITH ASSEMBLY OR MISSING PARTS PLEASE CONTACT US IMMEDIATELY

Ben Secrist 513-532-7062, Ben@brodbeckironworks.com

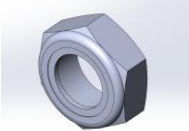
Parts List:

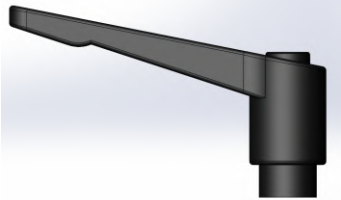
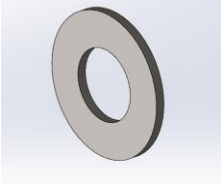
ITEM	DESCRIPTION	QTY	IMAGE
1	QUICK CHANGE ACCESSORY BRACKET	1	
2	1.5" SQ TOOL ARM 14" LG	1	
3	1/2" CARRIAGE BOLT 2- 1/2" LG	2	
4	1/2" THIN NYLOCK NUT	1	
5	1/2" TEFLON WASHER .020" THK	1	
6	BLACK ADJUSTABLE HANDLE 1/2"-13 INTERNAL THREAD	1	
7	1/2" FLAT SAE WASHER	2	

8	¼-20 THREADED HANDLE	2	
9	¼" CARRIAGE BOLT 1" LONG	2	

TOOL LIST

- 3/4" COMBO WRENCH OR SOCKET
- ADJUSTABLE WRENCH

QUICK CHANGE ATTACHMENT ASSEMBLY

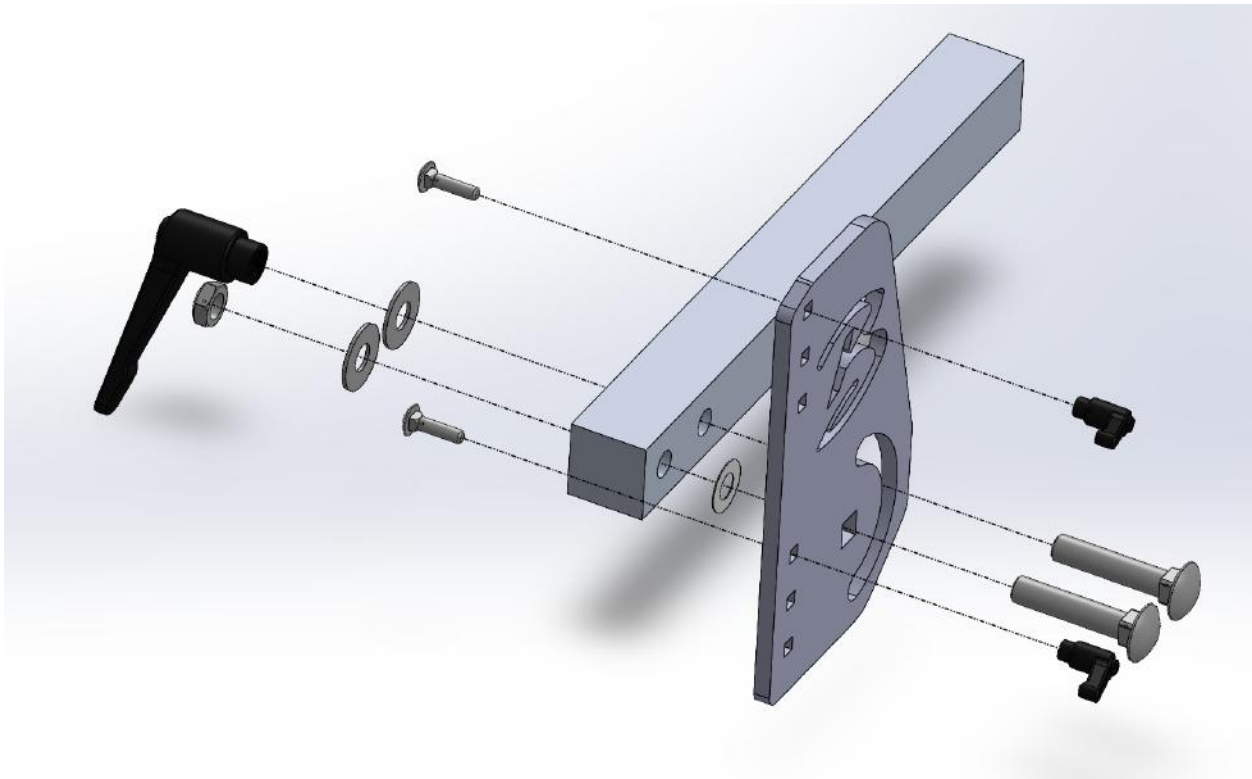

Insert $\frac{1}{2}$ -13 x 2.5" Carriage Bolts through the base plate into the arm.

Insert $\frac{1}{2}$ " Teflon washer between the plate and the arm on the front carriage bolt.

Install the $\frac{1}{2}$ -13 lock nut onto the front bolt with a washer.

Install the large black handle with a washer to the back bolt.

Insert the $\frac{1}{4}$ -20 x 1" carriage bolts through the base plate at the desired height.

Install small black handles onto the $\frac{1}{4}$ -20 carriage bolt.