

COMMERCIAL BUFFER 17-INCH FLOOR MACHINE - BASE ASSEMBLY

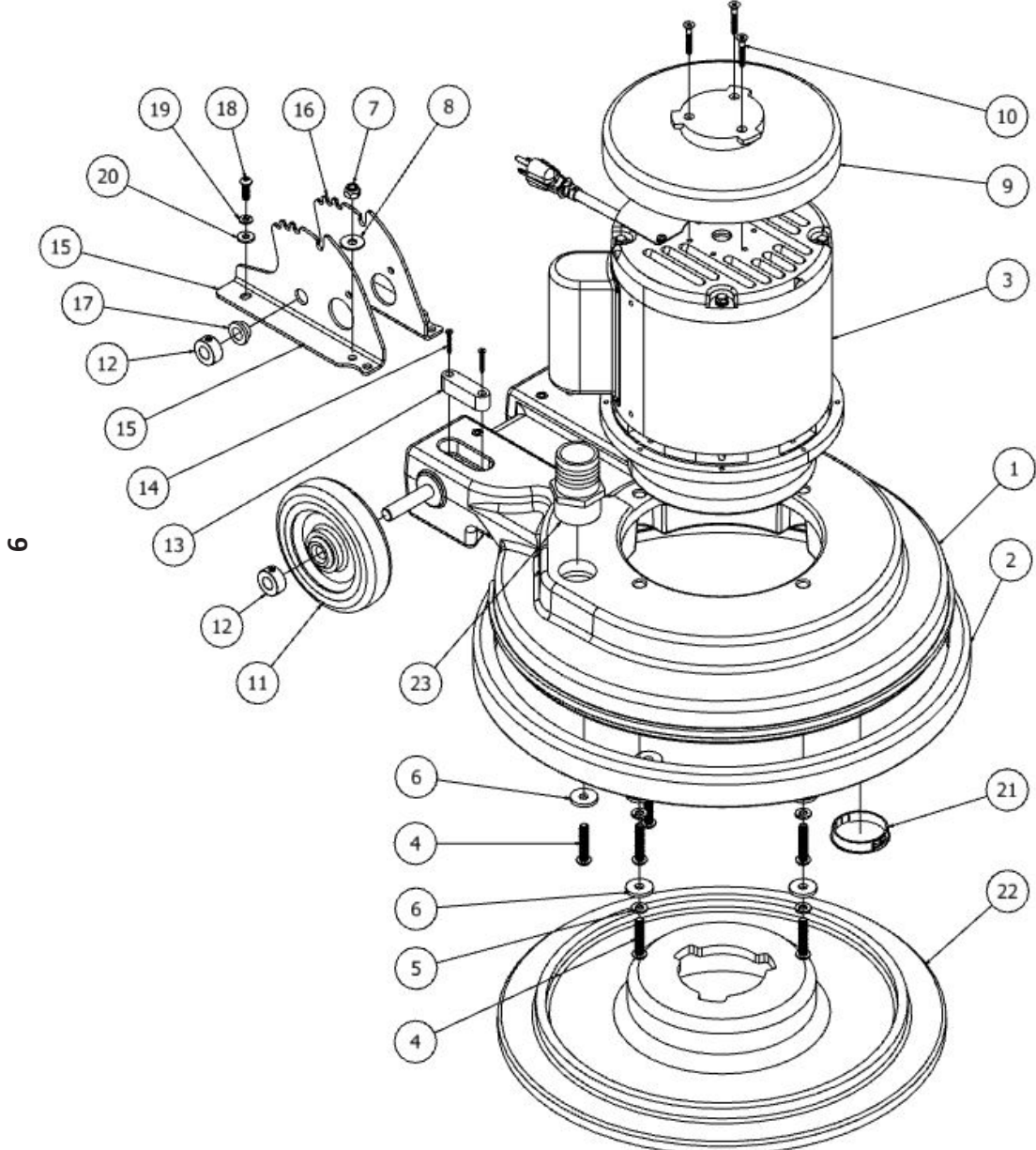

ITEM	QTY	PART NUMBER	DESCRIPTION
1	1	483.531312	BASE FM 17" ROTO 0.5" SHFT RED ONE DC TT
2	1	485.481202	BUMPER GREY PX17.ipt
3	1	483.535201	MOTOR & GEARBOX 175RPM HD 1.5HP
4	6	490.962474	SCREW .31-18X1.5 SHC ZINC GR8
5	4	490.980094	WASHER, SPLIT LOCK, .31, SS
6	6	490.980109	WASHER FLAT .31 X 1.0 ZINC
7	2	490.920012	NUT, NYLOCK, 5/16-18, ZINC
8	2	490.W243D	WASHER, FLAT, 5/16, SS
9	1	485.502373	COVER, MOTOR DRIP
10	3	483.962004	SCREW 10-32x1 1/4 OVAL HEAD PH
11	2	485.529701	WHEEL 5INCH URETHANE
12	4	490.542402	COLLAR, CLAMP, .50INCH
13	1	490.534801	INDICATOR LEVEL
14	2	490.962391	SCREW TAPPING #6 X 1.0
15	1	490.530801	BRACKET, HANDLE, RH
16	1	490.530802	BRACKET, HANDLE, LH
17	2	490.871101	BUSHING, FLANGE, .50IN
18	2	490.W189D	SCREW, HEX, 1/4-20 X .75, SS, PATCH
19	2	485.980002	WASHER, LOCK, SPLIT, .25
20	2	490.W104D	WASHER, FLAT, .25
21	1	490.536802	PLUG HOLE 2.0 INCH
22	1	483.505913	DRIVER, PAD, 17INCH
23	1	490.853304	FITTING, STR, BM24, PM20

COMMERCIAL BUFFER 17-INCH FLOOR MACHINE - HANDLE ASSEMBLY

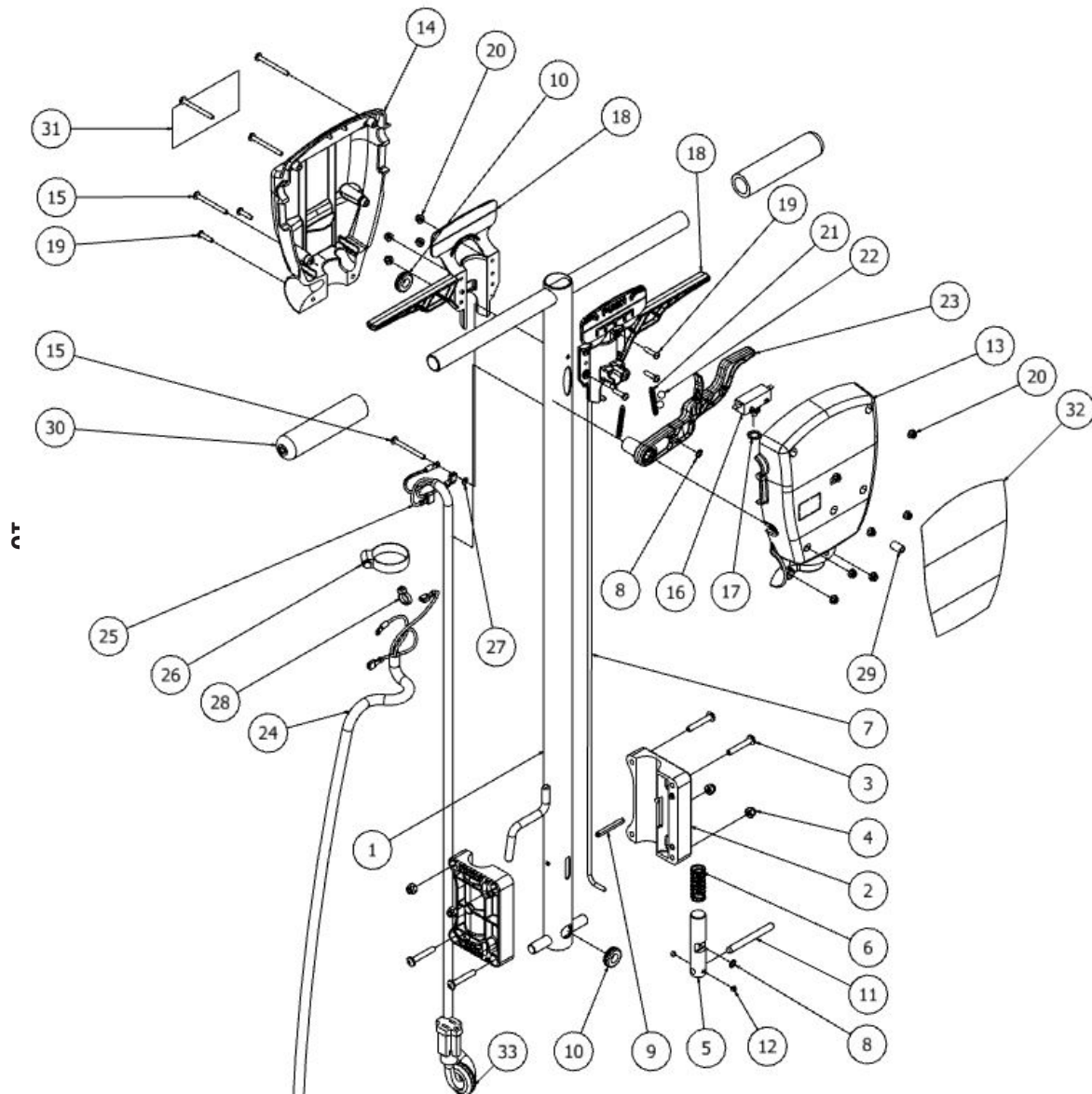

ITEM	QTY	PART NUMBER	DESCRIPTION
1	1	490.533901	HANDLE, WELDMENT, LONG
2	2	490.531303	BLOCK, CLAMP, HANDLE
3	4	490.962389	SCREW PAN .25-20 X 1.5
4	4	490.920011	NUT, NYLOCK, 1/4-20, ZINC
5	1	490.537001	PLUNGER, HANDLE
6	1	490.538301	SPRING COMPRESSION
7	1	490.537401	ROD, HANDLE, LONG
8	2	490.537301	RING RETAINING 3/16 INCH
9	1	490.925615	PIN SPRING .25 x 1.75
10	2	490.533801	GROMMET .50 ID .75 OD
11	1	490.925616	PIN DOWEL .31 X 3.0
12	2	490.962390	SCREW SET .25-20 X .188
13	1	490.534201	HOUSING, FRONT
14	1	490.534202	HOUSING, REAR
15	5	490.962471	SCREW #10-32 X 2 PHP
16	1	485.911561	SWITCH FM SNAP ON OFF CULUS
17	1	490.980021	WASHER-3/8 INT TOOTH LOCK
18	2	490.539201	TRIGGER, MOLDED, FM
19	6	490.962003	SCREW, PAN, #10-32 X .75, ZINC
20	11	490.920001	NUT, NYLOCK, #10-32, ZINC
21	2	490.858302	SPRING, EXTENSION
22	2	490.531301	BALL BEARING 3/8 INCH
23	1	490.539203	TRIGGER WITH JOGGLE
24	1	490.908129	CORD POWER 50FT 14-3 FM
25	1	490.908130	CORD SET HANDLE FM
26	1	490.5611A	CLAMP, HOSE, WORM
27	1	490.980018	WASHER #10 C-SUNK EXT SHKPRF
28	1	490.911117	TIE-CABLE .098 X 8 PLT-2
29	1	490.204179	HOSE .25ID .38OD
30	2	490.533701	GRIP FM CLOSED
31	1	490.515148	LABEL WARNING TRI-LINGUAL
32	1	490.535106	LABEL HANDLE FM TAYLOR TOOLS
33	1	490.253801	GROMMET .88ID 1.25HOLE .125THK

COMMERCIAL BUFFER 17-INCH FLOOR MACHINE - MOTOR & GEAR BOX ASSEMBLY

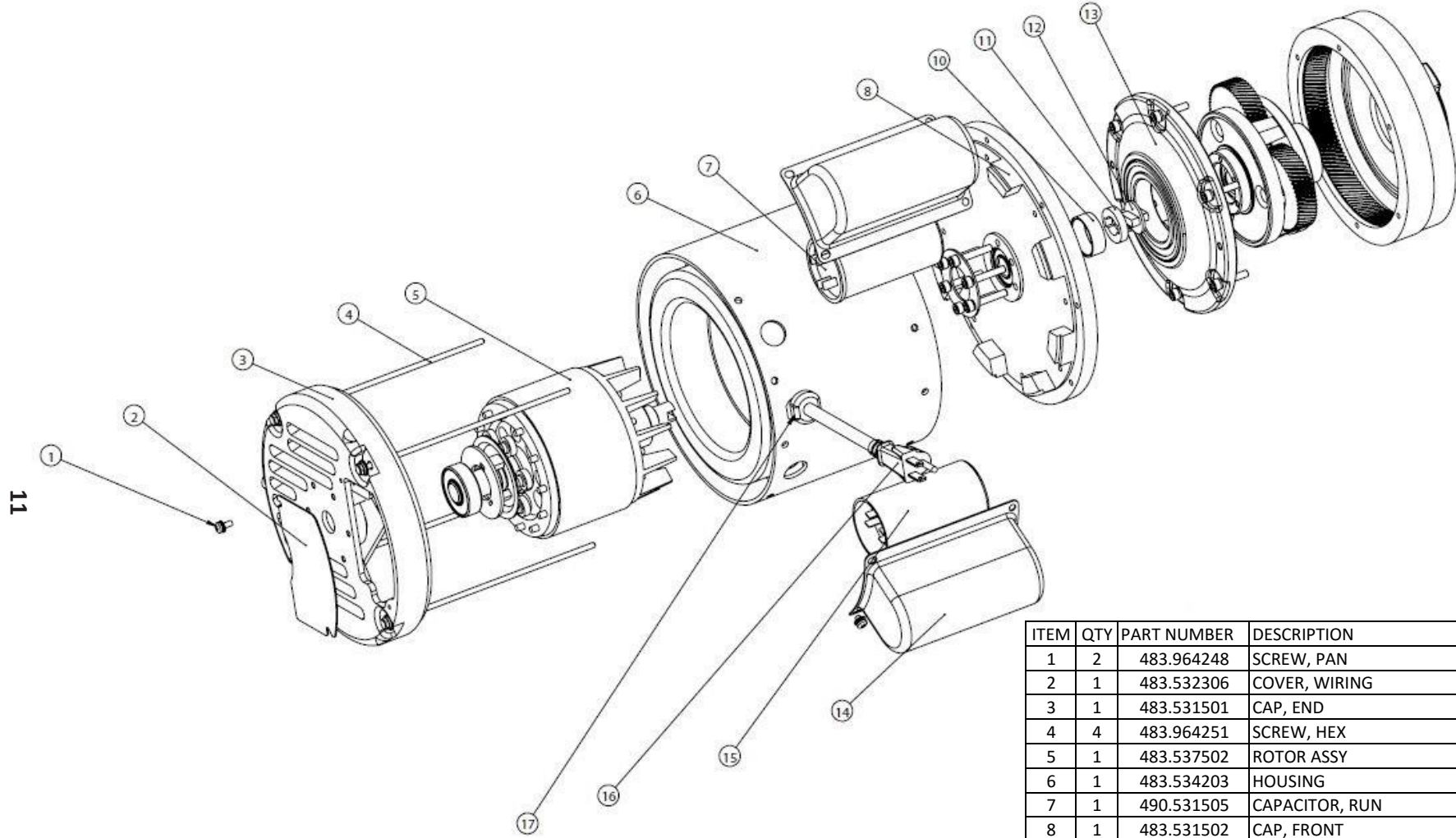

ITEM	QTY	PART NUMBER	DESCRIPTION
1	2	483.964248	SCREW, PAN
2	1	483.532306	COVER, WIRING
3	1	483.531501	CAP, END
4	4	483.964251	SCREW, HEX
5	1	483.537502	ROTOR ASSY
6	1	483.534203	HOUSING
7	1	490.531505	CAPACITOR, RUN
8	1	483.531502	CAP, FRONT
10	1	490.537302	RING
11	1	490.537303	RING
12	1	483.532401	COUPLING
13	1	483.533503	GEAR BOX ASSY
14	2	490.532305	COVER, CAPACITOR
15	1	483.531506	CAPACITOR, START
16	1	483.908132	CORD, POWER
17	1	483.531309	BUCKLE WIRE

COMMERCIAL BUFFER 17-INCH FLOOR MACHINE - SOLUTION TANK ASSEMBLY (OPTIONAL)

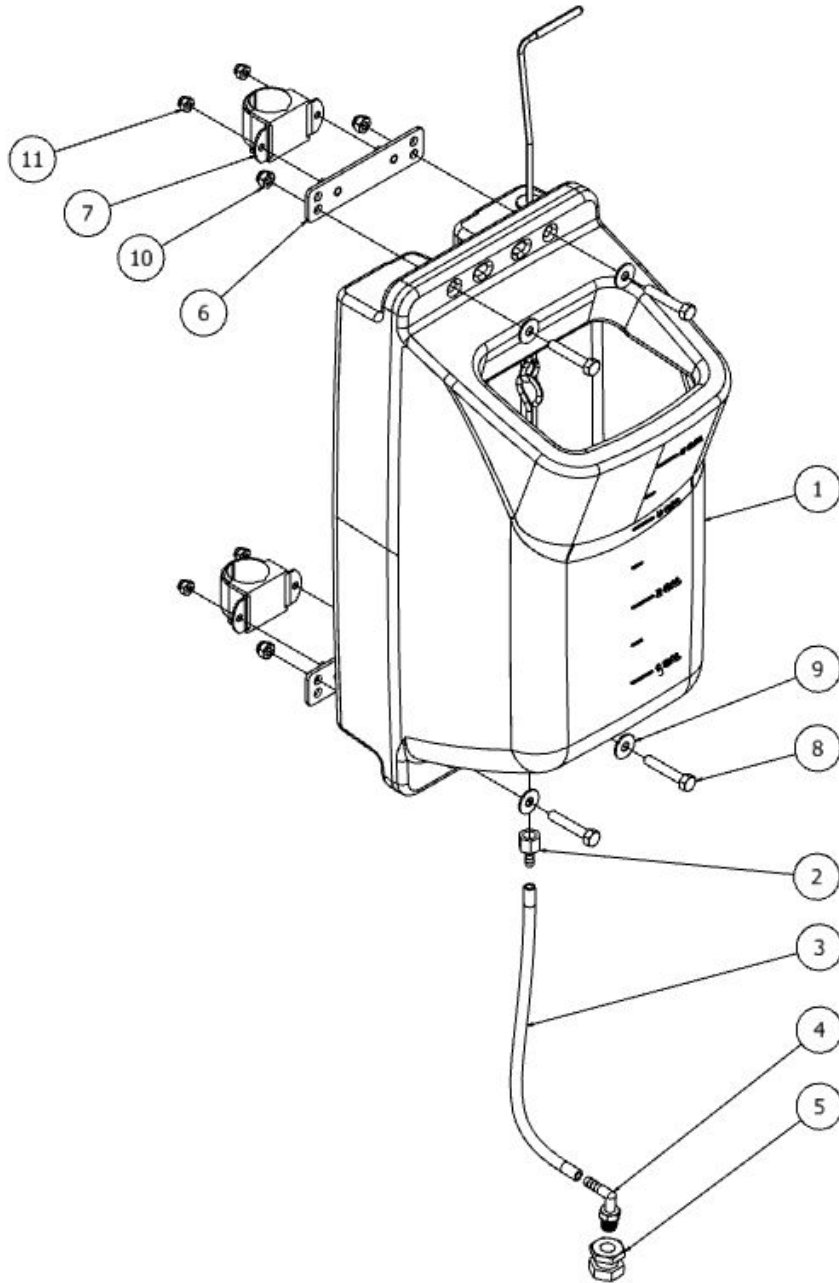

ITEM	QTY	PART NUMBER	DESCRIPTION
1	1	490.548601	TANK ASSY
2	1	490.533301	FITTING, STR, .25 FPT, .25 BARB BRASS
3	1	490.204179	TUBING, 1/4" DIA, 1 FT
4	1	490.533302	FITTING, ELBOW, .25NPT, .25 BARB
5	1	490.T4056	FITTING, BULKHEAD
6	2	490.546102	PLATE, ADAPTER, TANK
7	2	490.542002	CLAMP, U-SHAPED W/RUBBER
8	4	490.962270	SCREW, HEX, 5/16-18 X 1.75, SS
9	4	490.980007	WASHER, FLAT, .31 ZINC
10	4	490.920012	NUT, NYLOCK, 5/16-18, ZINC
11	4	490.920011	NUT, NYLOCK, 1/4-20, ZINC

