

5700

ALL DAY BATTERY RIDE-ON SCRAPPER INSTRUCTION MANUAL

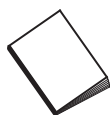

Read Manual Before Operating Machine

Table of Contents

Table of Contents	1-2
Features and Specifications	3
Safety	4-6
General Rules For Safe Operation	4-5
Characteristics of a Defensive Operator	5
Hydraulic Safety Tips	5
Silica Dust Warning	6
Battery/Charger Information	7-15
Battery General Information	7
Battery Installation	7
Battery Operation	8
Battery Charging	8
Battery Storage	9
Battery Testing	10
Battery Warranty	11
Battery Disposal	11
Charger Instructions	12-13
Commonly Asked Questions	14
Battery Troubleshooting	15
Machine Operation	16-24
Loading/Unloading	16
Center of Gravity	17
Job Site Movement	17
Operating Controls	18-19
Operational Tips	19
Dialing In the Machine	20
Applications Set-Up	22-24
Ditching	24
Blades	25-28
Cutting Heads	25
Types of Blades	25-27
Blade Sharpening	28
Machine Maintenance	29
Manual Slide Plate Removal	29
Raising or Lowering Manual Slide Plate	29
Dual Slide Plate Removal	29
Checking Oil Level	30
Oil Change Out	30
Hose Change Out	30
Wheel Motor Change Out	30
Foot Peg Removal	30
Pump Change Out	31
Valve Change Out	31
Motor Change Out	31
Hydraulic Cylinder Change Out	31
Rear Wheel Changing	31-32
Seat Replacement	32
Troubleshooting Guide	33
Parts List and Diagrams	34-50
Complete Parts List	34-35
External Parts	36
Cylinder Assembly	37
Slide Plate Assembly	37
Caster Wheel Assembly	38

Table of Contents

Rear Wheel Assembly	38
Electrical Box Assembly	39
Battery	39
Back up Beeper Assembly	40
Handle Switch	40
Instruction Tube	40
Foot Peg Assembly	40
Spool and Hose Parts	41
Filter and Tank Parts	41
Hydraulic Flow Diagram	42
Motor	43
Gear Pump Assembly	43
Labels	44
Weights & Wrench	45
Battery Wiring	46
Seat Wiring	47
Machine Wiring	48
Accessories	49-50
Material Safety Data Sheet (MSDS) Information	51-58
Guarantee	59

Features and Specifications

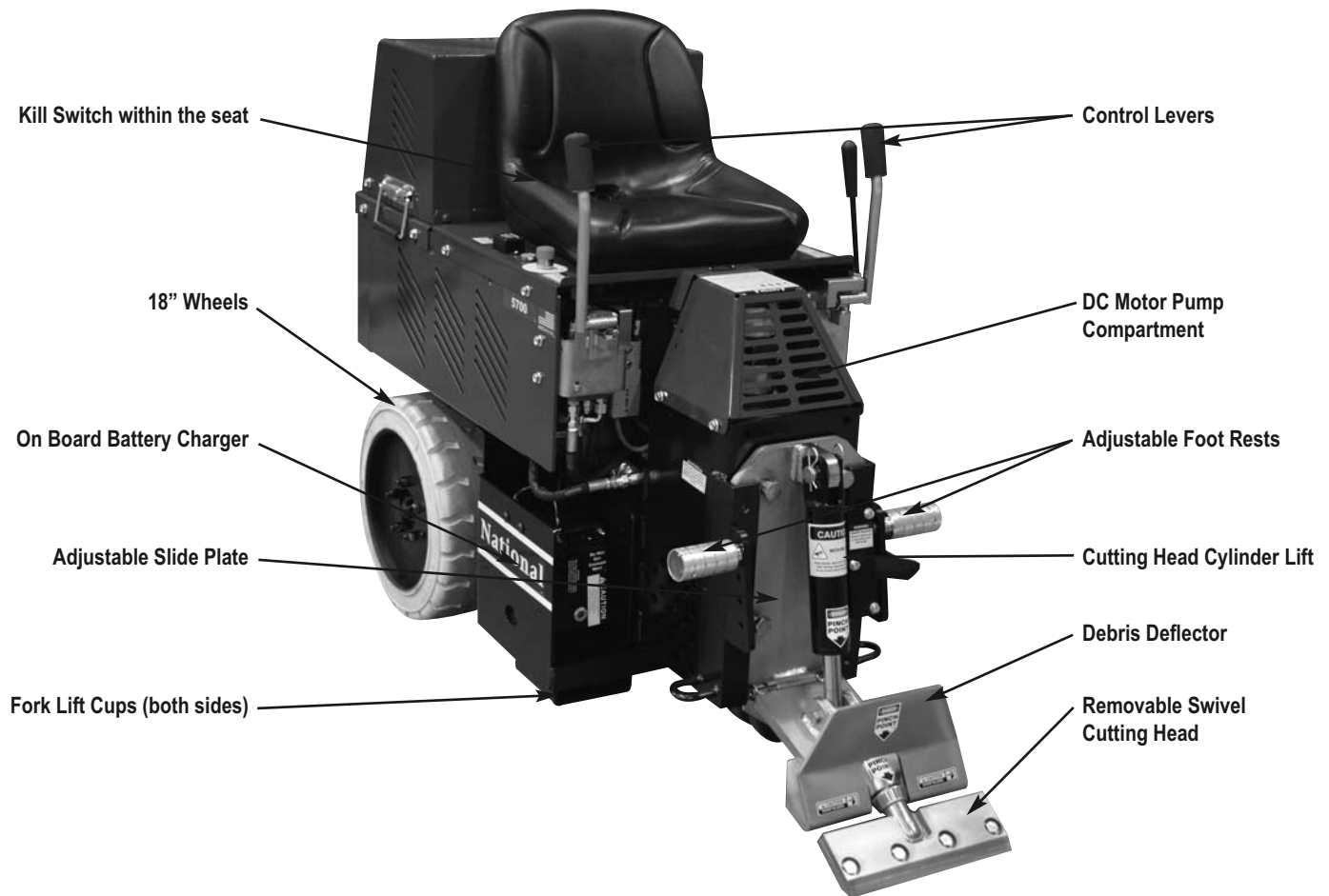

FEATURES

Kill Switch- Insures the machine will not function without someone in the operator seat.

18\" Wheels- Work on all types of application and debris build-up. They also work well for slippery/slimy residue (i.e. double stick).

On Board Battery Charger- Powered by 115 volts, it charges the 12 AGM batteries overnight.

Adjustable Slide Plate- Affords maximum versatility in blade settings.

Fork Lift Cups- Make it easier to load and unload on jobsites.

Control Levers- Forward, reverse, turn and break with easy move levers.

DC Motor Pump Compartment- Easy access for maintaining the machine.

Adjustable Foot Rests- For operator comfort.

Cutting Head Cylinder Lift- Change the angle of the cutting head with the control handle next to the operator seat.

Debris Deflector- Redirects debris away from the operator.

Removable Swivel Cutting Head- Assures continuous blade contact with the floor.

5700 SPECIFICATIONS

Width	Height	Length	Empty Weight	Fully Weighted	Removable Weight	Run Time	HP	Speed	Sound Level	Handle Acceleration	Handle Acceleration
24.5"	47.5"	54"	2069 lb.	2249 lb.	180 lb.	8-12 hours	4	up to 120 ft./min.	94-97 dB(A)	Left .216 m/s sq.	Right .306 m/s sq.

Safety

GENERAL RULES FOR SAFE OPERATION

READ AND SAVE ALL INSTRUCTIONS FOR FUTURE USE. Before use, be sure everyone operating this equipment reads and understands this manual as well as any labels packaged with or attached to the machine and components and view the instruction video. Extra copies of the manual and video are available.

1. **KNOW YOUR EQUIPMENT:** Read this manual and view instruction video carefully to learn equipment applications and limitations as well as potential hazards associated with this type of equipment.
2. **DISARM MACHINE:** Remove cutting head or drop cutting head to the floor when machine is not in use.
3. **DO NOT "SIDE HILL" MACHINE:** See Page 16.
4. **DISCONNECT CHARGER:** Disconnect machine from charger before operating machine.
5. **AVOID DANGEROUS ENVIRONMENTS:** Do not use in rain, damp or wet locations, or in the presence of explosive atmospheres (gaseous fumes, dust or flammable materials). Remove materials or debris that may be ignited by sparks.
6. **KEEP WORK AREA CLEAN AND WELL LIT:** Cluttered, dark work areas invite accidents.
7. **DRESS PROPERLY:** Do not wear loose clothing. These may be caught in moving parts. Keep hands and gloves away from moving parts.
8. **USE SAFETY EQUIPMENT:** Everyone in the work area should wear safety goggles or glasses complying with current safety standards. Wear hearing protection during extended use and a dust mask for dusty operations. Hard hats, face shields, safety shoes, etc. should be worn when specified or necessary.
9. **KEEP BYSTANDERS AWAY:** Children and bystanders should be kept at a safe distance from the work area to avoid distracting the operator. Operator should be aware of who is around them and their proximity. Support personnel should never stand next to, in front of or behind the machine while it is running; doing this could result in bodily injury or death. This appliance is not intended for use by persons (including children) with reduced physical, sensory or mental capabilities, or lack of experience and knowledge, unless they have been given supervision or instruction concerning use of the appliance by a person responsible for their safety. Children should be supervised to ensure that they do not play with the appliance.
10. **PROTECT OTHERS IN THE WORK AREA:** Provide barriers or shields as needed to protect others from debris and machine operation.
11. **USE PROPER ACCESSORIES:** Using accessories that are not recommended may be hazardous. Be sure accessories are properly installed and maintained. Do not delete a guard or other safety device when installing an accessory, attachment or servicing.
12. **CHECK FOR DAMAGED PARTS:** Inspect guards and other parts before use. Check for misalignment, binding of moving parts, improper mounting, broken parts and any other conditions that may affect operation. If abnormal noise or vibration occurs, turn the tool off immediately and have the problem corrected before further use. Do not use damaged equipment. Tag damaged machine "DO NOT USE" until repaired. A guard or other damaged parts should be properly repaired or replaced. For all repairs, insist on only identical National replacement parts.
13. **REMOVE ALL ADJUSTING KEYS AND WRENCHES:** Make a habit of checking that the adjusting keys, wrenches, etc. are removed from the tool before turning it on.
14. **GUARD AGAINST ELECTRIC SHOCK:** Prevent body contact with grounded surfaces such as pipes, battery plug connection, radiators, ranges and refrigerators. When scoring or making cuts, always check the work area for hidden wires or pipes to reduce shock hazards.
15. **AVOID ACCIDENTAL STARTING:** Be sure equipment is turned off before plugging it in. Do not use if the power switch does not turn the machine on and off properly.
16. **DO NOT FORCE EQUIPMENT:** Equipment will perform best at the rate for which it was designed. Excessive force only causes operator fatigue, increased wear and reduced control.
17. **KEEP HANDS AND FEET AWAY FROM ALL CUTTING EDGES AND MOVING PARTS.**
18. **WEAR GLOVES WHEN CHANGING BLADES.**
19. **DO NOT ABUSE CORD:** Never unplug the battery charger by yanking the cord from the outlet or from the battery. Pull plug rather than cord to reduce the risk of damage. Keep the cord away from heat, oil, sharp objects, cutting edges and moving parts.
20. **DO NOT OVERREACH. MAINTAIN CONTROL:** Stay properly seated. Keep proper footing and balance at all times. Maintain a firm grip.
21. **STAY ALERT:** Watch what you are doing, and use common sense. Do not use when you are tired, distracted or under the influence of drugs, alcohol or any medication causing decreased control.
22. **STARTING MACHINE:** On/off switch must be in off position before connecting to power source.
23. **UNPLUG EQUIPMENT:** Disconnect battery charger before servicing or when operating.
24. **MAINTAIN EQUIPMENT CAREFULLY:** Keep control levers dry, clean and free from oil and grease. Keep cutting edges sharp and clean. Follow instructions for lubricating and changing accessories. Have damaged parts repaired or replaced. Only replace the supply cord with the type specified in the instruction manual.

25. **STORE IDLE EQUIPMENT:** When not in use, store in a dry, secured place. Keep away from children. Remove blade or keep blade lowered to the floor (disarm machine).
26. **MAINTAIN LABELS AND NAME PLATES:** These carry important information. If unreadable or missing, contact National for a free replacement.
27. **MACHINE IS HEAVY, DO NOT DROP:** Counter weights are heavy. Take caution when removing or reassembling. Take caution when moving or transporting. Do not drop batteries.
28. **BATTERIES:** Periodically inspect batteries, charger and all plug connections. Only replace batteries by the manufacturer or its servicing agent. Do not open or tamper with Batteries. Doing so voids all warranties and could cause injury due to electric shock.
29. **COMMERCIAL APPLICATION:** Machine is intended for commercial use only.

CHARACTERISTICS OF A DEFENSIVE OPERATOR

A GOOD OPERATOR IS A “DEFENSIVE” OPERATOR!!

QUALITIES INCLUDE:

Education: Learns about the machine and the environment.

Alert: Stays alert at all times...never lets guard down.

Skills: Only performs duties he/she are qualified to do. Always tries to improve.

Judgment: Plays it safe. Doesn't take chances.

Common Sense: Does the right thing without having to be told. Applies knowledge.

Recognizes the Hazards: Maintains alertness. Anticipates danger.

Understands the Defense: Knows that safety isn't an accident...it's a thinking person's choice.

Acts Correctly: Does not cave in to peer pressure. Performs correctly when supervised or not.

HYDRAULIC SAFETY TIPS

MAINTAINING A SAFE WORK ENVIRONMENT

Establishing a safe working environment in and around your hydraulic equipment is just common sense. The easiest and most effective way to avoid problems is to make sure associates understand their equipment, know how to operate it safely and recognize the danger it represents if handled carelessly. A few things you must be aware of include:

1. **PRESSURE:** Hydraulic fluid under pressure is dangerous and can cause serious injury.
2. **FLAMMABILITY:** When ignited, some hydraulic fluids can explode and/or cause fires.
3. **MECHANICAL:** Hydraulic fluid creates movement, which causes parts of your equipment to move or rotate. Always be aware of what you are doing.
4. **MOISTURE:** Use caution when operating in wet or high moisture conditions. Make sure all electrical fittings, switches, cords plus stain reliefs are in good condition. Always unplug when not in use and when doing any service work.
5. **ELECTRICAL:** Faulty wiring can also be an electrical hazard. A regular preventive maintenance program should always include a wiring check. Unplug batteries and/or charger before serving.
6. **TEMPERATURE:** Because this machine operates at a relatively low pressure, overheating is not common. If surface of tank becomes too hot to touch by hand (above 130°), shut off machine and allow to cool off.

PRESSURE

Our system runs at or below 2,000 psi. Never look for a leak when unit is under pressure. Using your hand could cause serious injury. A few common ways to encounter hydraulic fluid under pressure include:

CAUTION: NEVER USE YOUR HANDS TO CHECK FOR LEAKS OVER HOSE OR HYDRAULIC CONNECTIONS. USE A PIECE OF CARDBOARD TO LOCATE A PRESSURIZED LEAK. FOR LOW PRESSURE LEAKS (DRIPS), USE A RAG TO CLEAN THE AREA AND DETERMINE WHERE THE LEAK ORIGINATES.

Safety

PRESSURE (CONTINUED)

1. **PINHOLE:** Fluid under pressure can cause serious injury. It can be almost invisible escaping from a pinhole, and it can pierce the skin into the body. Do not touch a pressurized hydraulic hose assembly with any part of your body. If fluid punctures the skin, even if no pain is felt, a serious emergency exists. Obtain medical assistance immediately. Failure to do so can result in loss of the injured part or death.
2. **LEAK:** Keep fittings and hoses tight. Only check and service when not under pressure. Leaking hydraulic fluid is not only unsightly, it's hazardous. In addition to making workplace floors slippery and dangerous, leaks also contaminate the environment. Before cleaning an oil spill, always check EPA, state and local regulations.
3. **BURST:** Whether due to improper selection or damage, a ruptured hose can cause injury. If it bursts, a worker can be burned, cut, injected or may slip and fall.
4. **COUPLING BLOW-OFF:** If the assembly is not properly made or installed, the coupling could come off and hit or spray a worker, possibly resulting in serious injury. Never operate machine without guards.

FLAMMABILITY

With the exception of those comprised primarily of water, all hydraulic fluid is flammable when exposed to the proper conditions (including many "fire-resistant" hydraulic fluids).

Leaking pressurized hydraulic fluids may develop a mist or fine spray that can flash or explode upon contact with a cause of ignition. These explosions can be very severe and could result in serious injury or death.

Precautions should be taken to eliminate all ignition sources from contact with escaping fluids, sprays or mists resulting from hydraulic failures. Sources of ignition could be electrical discharges (sparks), open flames, extremely high temperatures, sparks caused by metal-to-metal contact, etc.

HYDRAULIC FLUID

Only use Texaco Rando 46 Hydraulic Oil or Compatible Fluid like IS032. Non-compatible fluids could cause damage to unit or serious injury.

WARNING: SILICA DUST WARNING



GRINDING/CUTTING/DRILLING OF MASONRY, CONCRETE, METAL AND OTHER MATERIALS CAN GENERATE DUST, MISTS AND FUMES CONTAINING CHEMICALS KNOWN TO CAUSE SERIOUS FATAL INJURY OR ILLNESS, SUCH AS RESPIRATORY DISEASE, CANCER, BIRTH DEFECTS OR OTHER REPRODUCTIVE HARM. IF YOU ARE FAMILIAR WITH THE RISKS ASSOCIATED WITH THE PARTICULAR MATERIAL BEING CUT, REVIEW THE MATERIAL SAFETY DATA SHEET AND/OR CONSULT YOU EMPLOYER, THE MATERIAL MANUFACTURER/SUPPLIER, GOVERNMENTAL AGENCIES SUCH AS OSHA AND NIOSH AND OTHER AUTHORITIES ON HAZARDOUS MATERIALS. CALIFORNIA AND SOME OTHER AUTHORITIES, FOR INSTANCE, HAVE PUBLISHED LISTS OF SUBSTANCES KNOWN TO CAUSE CANCER, REPRODUCTIVE TOXICITY, OR OTHER HARMFUL EFFECTS. CONTROL DUST, MIST AND FUMES AT THE SOURCE WHERE POSSIBLE. IN THIS REGARD USE GOOD WORK PRACTICES AND FOLLOW THE RECOMMENDATIONS OF THE MANUFACTURER/SUPPLIER, OSHA/NIOSH, AND OCCUPATIONAL AND TRADE ASSOCIATIONS. WHEN THE HAZARDS FROM INHALATION OF DUST, MISTS AND FUMES CANNOT BE ELIMINATED, THE OPERATOR AND ANY BYSTANDERS SHOULD ALWAYS WEAR A RESPIRATOR APPROVED BY OSHA/MSHA FOR THE MATERIAL BEING CUT.

Battery/Charger Information

BATTERY GENERAL INFORMATION

Machine is equipped with twelve (12) 180 Amp hour, 48 volt battery packs put in parallel to create 360 amp hours. Batteries do not take a memory allowing recharge at any state.

BATTERY INSTALLATION

Proper battery installation is the first step in getting the best performance out of our batteries.

SELECTING THE APPROPRIATE CABLE SIZE

Cables must be sized to carry the maximum expected load. Under-sized cables can result in over-heating, melted connections and are a potential fire hazard.

Refer to **Table 1** for the current carrying capacity by cable size. These values are for cable lengths of 6 feet or less. It is preferable that all cables in a series connection are the same length and all cables in a parallel connection are the same length. **NOTE:** To significantly reduce the amount of heat generated at the terminals, use cables with solder-dipped ends.

TERMINAL CONNECTIONS

Terminal connections must be tightened using the correct torque values as defined in **Table 2**. Over- or under-tightened connections can result in terminal breakage, over-heating and/or meltdown. Using the proper torque value will provide optimum conductivity. Use a wrench with an insulated or rubber coated handle when making terminal connections to avoid a short circuit. See **Diagram 1** for proper washer placement.

CAUTION: NEVER PLACE A WASHER BETWEEN THE MATING SURFACES OF THE TERMINALS AND CABLES; THIS WILL COMPROMISE ELECTRICAL TRANSMISSION AND INCREASE RESISTANCE, RESULTING IN EXTREME HEAT GENERATION AND PROBABLE TERMINAL MELTING.

BATTERY ORIENTATION

The ideal placement of batteries is upright. AGM batteries can be placed on their side if necessary. It is preferred that all the batteries within a pack be placed in the same orientation.

NOTE: Never place batteries in an inverted orientation.

SERIES CONNECTIONS

There is more than one option to meet your voltage requirements. For example, for a 12 Volt system you may use one 12 Volt battery or two 6 Volt batteries wire in a series to make up the 12 Volts. You may use as many batteries as you need to make up the system voltage. Connect the positive of one battery to the negative of the next through the entire string. See **Diagram 2** on page 8 for the proper series connection.

Series Connection Example: Two 6V, 224AH batteries= 12V, 224AH

PARALLEL CONNECTION

There is more than one option to meet your energy requirements. For example, to meet the requirements for a 210 Amp-Hour system you may use one 210 Amp-Hour battery or two 105 Amp-Hour batteries wired in parallel to make up the 210 Amp Hours. Connect all the positive terminals together and all the negative terminals together in the string. See **Diagram 3** on page 8 for proper parallel connection.

Parallel Connection Example: Two 12V, 105AH batteries = 12V, 210AH

SERIES/PARALLEL CONNECTIONS

Batteries can be connected in both series and parallel to attain the desired system voltage and energy requirements. See **Diagram 4** below for proper series/parallel connections.

Series/Parallel Connection Example: Four 12V, 115AH batteries = 24V, 230AH

TABLE 1

Cable Gauge (AWG)	Ampacity (Amps)
14	25
12	30
10	40
8	55
6	75
4	95
2	130
1	150
1/0	170
2/0	265
3/0	360

TABLE 2

Terminal Type	lbs-in	Nm
M6	50-70	5.6-7.9
MS	85-95	9.6-10.7
M6M -Stud	50-70	5.6-7.9
M10M- Stud	110-125	12.4-14.1
FR45	70-90	7.9-10.2
TP07-AP	50-70	5.6-7.9
TPOS-AP	50-70	5.6-7.9
AP	50-70	5.6-7.9
DT		
AP	50-70	5.6-7.9
STUD	110-125	12.4-14.1

Note: For values in lbs-ft, divide lbs-in by 12.

DIAGRAM 1

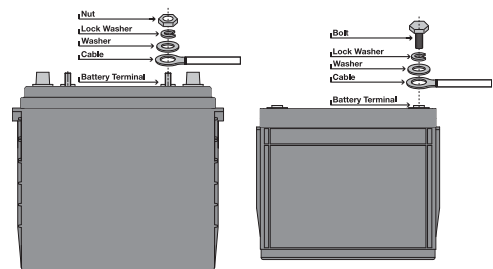

Battery/Charger Information

DIAGRAM 2

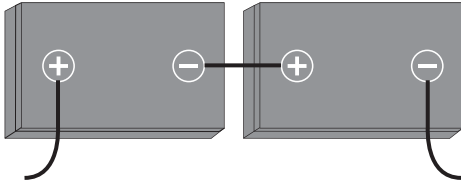

DIAGRAM 3

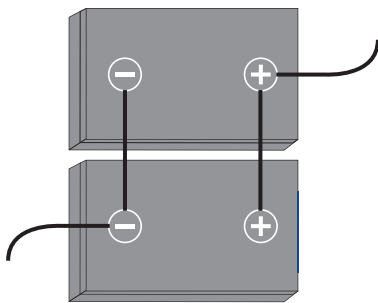

DIAGRAM 4

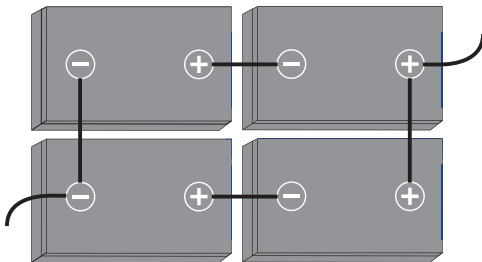

DIAGRAM 5

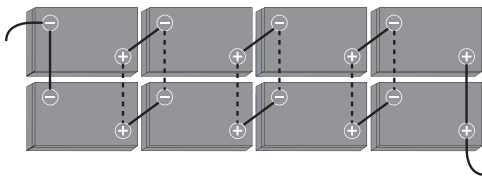

TABLE 3

Battery Nominal Voltage	Open Circuit Voltage (OCV)
6V	< 6.2V
8V	< 8.3V
12V	<12.5V

NOTE: For optimum performance, the systems positive and negative leads should be connected diagonally opposite (catty-corner) from each other as shown in **Diagram 4**.

CROSS TYING BATTERIES IN PARALLEL PACKS

In order to maintain balance in parallel battery packs it is best to cross tie the batteries. This method of connection will maximize the performance and life of your battery system. Cross-tying batteries means connecting positives to positives and negatives to negatives of each adjacent battery in the set. See **Diagram 5** for proper cross tying connections. The dotted lines represent the cross tied cables. **NOTE:** Leave some space between batteries for airflow and minor battery expansion.

CHARGING BATTERIES BEFORE USE

New AGM batteries that have only been stored for up to 6 months will not need to be charged prior to being put into service.

If new AGM batteries have been stored for more than 6 months and/or in an exceptionally hot environment a charge may be necessary prior to being put into service.

Check the open circuit voltage (OCV) of each battery in the set and if any battery within the set is less than the values in **Table 3**, recharge the battery set.

If the charger has a maintenance mode select that mode to boost charge the batteries. Otherwise run the normal charge cycle. **NOTE:** If the batteries are not charged prior to being put into service, you may experience a slight reduction in range on the first cycle.

BATTERY OPERATION

The performance and life of a battery will vary with application, usage, temperature and depth of discharge. AGM batteries tend to deliver higher than their rated capacity (up to 10-15% higher) for -30 cycles until they are "broken in" and settle at their rated capacity.

TEMPERATURE EFFECTS ON BATTERY PERFORMANCE AND LIFE

Operating batteries above 80°F (27°C) will yield runtimes above the rated capacity and operating batteries below 80°F (27°C) will yield runtimes below the rated capacity. Cold temperatures can significantly reduce battery capacity. See **Chart 1**.

Although higher temperatures increase the battery capacity they also accelerate corrosion and reduce overall battery life. For example, batteries operating continuously at 100°F (37.8°C) could experience as much as 25% reduction in life.

Recommended operating temperature range is 5°F to 104°F (-15°C to 40°C). Maximum operating temperature range is -40°F to 160°F (-40°C to 71°C).

DEPTH OF DISCHARGE VERSUS BATTERY LIFE

Battery cycle life will vary significantly depending on the depth of discharge. The deeper the depth of discharge the fewer cycles a battery will deliver. Conversely, the shallower the depth of discharge the more cycles a battery will deliver. See **Chart 2**. **NOTE:** To optimize the health of your battery, limit discharge to 80%.

BATTERY CHARGING

Using the proper charger is critical to the performance and life of your battery. If you're not sure if you have the right charger for AGM batteries call National technical support for verification.

CHARGER INSPECTION

1. The charger cable should be insulated and free of breaks or cuts.
2. The cable connectors should be clean and properly mated with the battery terminals to ensure a snug connection.

Battery/Charger Information

- The charger's AC cord should be free of breaks or cuts and the wall plug should be clean.

CHARGING YOUR BATTERIES

- Use an AGM charger or setting when available.
- Never use a Gel charger or setting on an AGM battery, as it will undercharge the battery and significantly reduce battery capacity and life.
- Many, but not all, wet battery chargers will work for AGM. Call technical support to verify your charger. Be prepared to provide the make and model of your charger.
- Batteries should be fully charged after each use. Opportunity charging can be done but the batteries should be fully charged at least every other day if they are used daily.
- Charge in a ventilated area as gasses may be released through the pressure relief valve if the batteries are excessively over-charged.
- If the charger does not have temperature compensation, avoid charging at temperatures below 5°F (-15°C) or above 122°F (50°C).

CHARGING PARAMETERS

Most chargers come pre-set from the factory. If your charger is pre-programmed use the information below to check if the settings are compatible with AGM batteries. If you have a programmable charger or inverter, use the following information for settings.

CURRENT

The recommended bulk current is 20% of the 20 Hr. AH capacity or $0.20 \times C_{20}$ (20 Hr Capacity in AH).

Example:

DC115-12 is rated at 115AH@ 20Hrs. recommended bulk current is $0.20 \times 115 = 23$ Amps
The maximum allowable bulk current is 35% of the 20 Hr. AH capacity or $0.35 \times C_{20}$ (20 Hr Capacity in AH), unless otherwise stated.

Example:

DC115-12 is rated at 115 AH @ 20Hrs. maximum bulk current is $0.35 \times 115 = 40$ Amps

VOLTAGE SETTINGS

Reference **Table 4**.

TEMPERATURE COMPENSATION

If you have a programmable charger or inverter that has a temperature compensation setting, it should be set to $-4\text{mV}/^\circ\text{C}/\text{cell}$ or $-2\text{mV}/^\circ\text{F}/\text{cell}$.

Table 5 has the temperature compensated voltage values for a 12V battery. For 24V, 36V or 48V system, multiply the values in the table by 2, 3 or 4 respectively.

BATTERY STORAGE

AGM batteries have a much longer shelf life than wet lead-acid batteries. With a self-discharge of only 1-3% per month, AGM batteries can be stored for a year or longer without needing to be charged.

BATTERY STORAGE PROCEDURE

- Charge batteries before they are placed in storage.
- Disconnect the batteries from the equipment and charger to eliminate any parasitic loads.
- Check the batteries based on conditions and schedule in **Table 6**.
- Check the open circuit voltage (OCV) of each battery in the set and if any battery within the set is less than the values in **Table 7**, recharge the battery set.

CHART 1

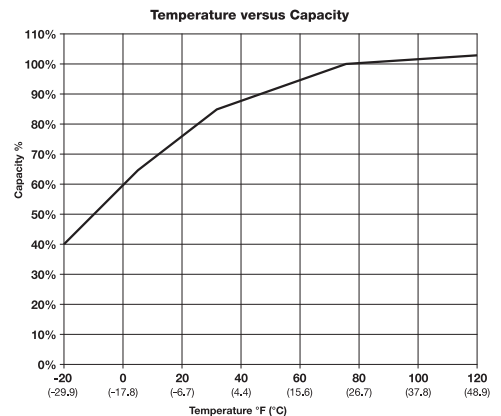

CHART 2

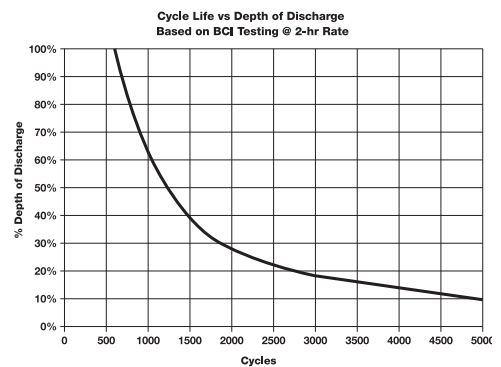

TABLE 4

Charge Stage	12V Battery Voltage	24V Battery Voltage	36V Battery Voltage	48V Battery Voltage
Bulk	14.7V	29.4V	44.1V	58.8V
Absorption	14.7V	29.4V	44.1V	58.8V
Float	13.7V	27.3V	41.0V	54.6V

TABLE 5

Charge Stage	32°F (0°C)	50°F (10°C)	68°F (20°C)	77°F (25°C)	86°F (30°C)	104°F (40°C)
Bulk & Absorption	15.30V	15.06V	14.82V	14.70V	14.58V	14.34V
Float	14.25V	14.01V	13.77V	13.65V	13.53V	13.29V

TABLE 6

Storage Temperature	Storage Time Period
Below 68°F (20°C)	9 Months
68°F to 86°F (20°C to 30°C)	6 Months
Above 86°F (30°C)	3 Months

Battery/Charger Information

TABLE 7

Battery Nominal Voltage	Open Circuit Voltage (OCV)
6V	< 6.2V
8V	< 8.3V
12V	<12.5V

CHART 3

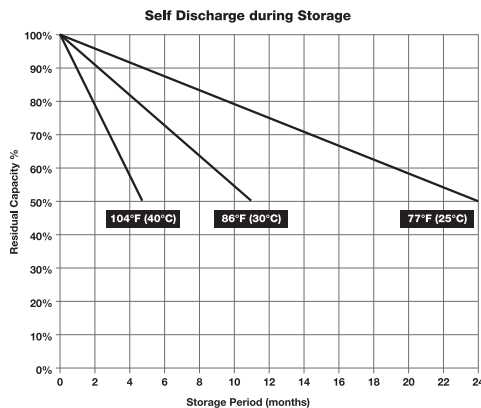

- If the charger has a maintenance mode select that mode to boost charge the batteries. Otherwise run the normal charge cycle.
- If the batteries are stored less than the time periods in **Table 6**, they do not need to be recharged prior to being put back into service.

TEMPERATURE EFFECTS ON SELF-DISCHARGE

If the storage environment is hot, batteries will self-discharge faster than in a cold environment. See **Chart 3**.

STORAGE TEMPERATURE RANGE

National recommends storing batteries between 5°F (-15°C) and 122°F (50°C). The maximum storage temperature allowed is -40°F (-40°C) and 160°F (71°C). Store batteries in a cool, dry environment to minimize self discharge.

BATTERY TESTING

Testing batteries can be complex and there are many application specific variables that cannot be considered in one simple test. This section is a guide to help you determine the overall condition of your batteries. Contact your local National distributor for assistance.

TEST PREPARATION

- Check that battery cables are in good condition. Replace any damaged or broken cables.
- Check that all terminal connections are tightened to proper torque specification. See **Table 2**.
- Fully charge batteries.
- Let batteries rest for at least 8 hours once the charge is complete.

OPEN CIRCUIT VOLTAGE TEST

- Check and record open circuit voltage (OCV) of each battery.
- If all the batteries are below 6.1V (6V battery), 8.1V (8V battery) or 12.2V (12V battery) the set is failed. Replace the entire set of batteries. In this situation the battery set had either provided all its available energy or was severely abused.
- Otherwise any battery that is 0.25V lower than the highest battery voltage (6V battery), 0.35V lower than the highest battery voltage (8V battery) or 0.5V lower than the highest battery voltage (12V battery) might have failed. Make note of these batteries.

NOTE: All batteries in a good set should be above 6.4V (6V battery), 8.5V (8V battery) and 12.7V (12V battery) when fully charged after at least 8 hours of rest.

DISCHARGE TEST (IF YOU DO NOT HAVE A DISCHARGER PROCEED TO NEXT SECTION)

- Connect and start discharger.
- Record minutes (runtime) when discharge is complete. Correct runtime minutes for battery temperature using the following formula: $Me = Mr [1 - 0.009 (T-27)]$ where Me is the corrected minutes, Mr is the minutes recorded and T is the temperature at the end of discharge in °C.
- If the set runs more than 50% of its rated capacity, the batteries are good - test is complete.
- If the set runs less than 50% of its rated capacity, reconnect the discharger and while under the discharge load; record the end of discharge voltage of each battery.
- The batteries that are 0.5V lower than the highest end of discharge voltage should be noted.
- If the set delivered less than 50% of its rated capacity, and the same batteries that were noted in "Open Circuit Voltage Test" section Step 3 were also the ones noted in this section Step 5, those batteries are most likely failed and should be replaced. Follow the replacement instructions.

Battery/Charger Information

OPTIONAL TEST

After completing the “Test Preparation” and “Open Circuit Voltage Test” sections follow these steps:

1. Operate the vehicle/equipment until battery performance decreases.
2. Record voltages during and after operation.
3. Record time and distance of operation.
4. Provide the voltage, time and distance data to National technical support.
5. This data will be analyzed in comparison to what is expected of the vehicle/equipment.

BATTERY REPLACEMENT INSTRUCTIONS

Charge the set of batteries before replacing the failed ones, as long as it is safe to do so, to make sure the good batteries are fully charged. If possible, replace failed batteries with good batteries around the same age from another piece of equipment. Try to avoid mixing new batteries in equipment with old batteries. Put all new batteries in the same piece of equipment. For battery replacement, follow the installation instructions on page 7.

BATTERY WARRANTY

With the exception to standard parts, batteries for 5700-AUS come with a 12 month **prorated** warranty. Any and all warranty for batteries are considered null and void if the battery has been tampered with, opened or used in any other purpose than intended. In addition, only a National Certified Technician is authorized to replace, inspect and/or conduct service checks on the batteries.

BATTERY DISPOSAL

Battery must be recycled or disposed of in an environmentally sound manner. Do not place used batteries in regular trash. Do not expose the battery to fire or high heat as batteries may explode. Care must be taken not to short terminals together with metal objects: jewelry, keys, nails, screws, tools, etc. Do not attempt to disassemble battery, fire or injury may result. Prior to disposal, protect terminals with heavy insulating tape to prevent shorting.



Battery/Charger Information

CHARGER INSTRUCTIONS

▲

CAUTION: PLEASE READ ALL INSTRUCTIONS AND SAFETY INFORMATION FOR CHARGER BEFORE OPERATING OR PREFORMING MAINTENANCE.

QUICK START INSTRUCTIONS:

Check that the temporary label on top of the charger marked with the profile setting matches your battery type. If not see the reprogramming section.

These chargers work very simply. Once connected and plugged into AC power, the LED will flash red for a few seconds, then turn steady red. When the cycle is 80% complete it will turn yellow, and finally green when cycle is complete.

If the profile is set to maintain the battery(s), the LED will flicker green. If the profile is set to shut off, the cycle will end with a steady green. The LED may also flicker when it is at the high limit of the charge cycle.

To discontinue charging, unplug AC power.



Steady, or flickering
100% complete

Look to the Troubleshooting section for any deviations from this.

EQUALIZATION:

When using multiple batteries in a series string, cells become uneven during charge and discharge cycles. At least once a month perform two charge cycles back to back, this will give a chance for cells that are lagging behind to catch up, and is important to overall battery performance.

NOTE: This only needs to be done when using Wet cell, or AGM settings with standard or extended gassing/absorption cycles. (Switch #1 ON).

SAFETY INFORMATION AC WIRING:

Before making AC connections, refer to the requirements on the charger ID label. If your charger is not equipped with an AC plug, have a qualified electrician install one.

To reduce the risk of fire, use this charger only on branch circuits that are protected by a circuit breaker or fuse, and that are adequate to carry the power drawn by the charger. All wiring should be in accordance with applicable national and local codes and ordinances.

This battery charger must be grounded to reduce the risk of electric shock. 240 volt chargers are equipped with a grounding type plug.

If an extension cord must be used, make sure it is in good condition. Use a three conductor cord no smaller than the size being used on the charger, and keep it as short as possible. Thirteen (13) feet or less is recommended. The use of an improper extension cord could result in a risk of a fire of electric shock. Locate all cords so that they will not be stepped on, tripped over, or otherwise subjected to damage or stress.

▲

WARNING: DO NOT USE THIS CHARGER ON A TWO POLE UNGROUNDED OUTLET OR ATTEMPT TO BREAK OFF THE GROUND PRONG FOR USE ON A RECEPTACLE OR EXTENSION CORD NOT HAVING A GROUND.

OTHER SAFETY INFORMATION:

Do not use charger if it shows signs of physical stress, or if DC output leads or connector feel hot when used.

Do not disconnect the DC output clamps, or connector from the batteries when the charger is on. The resulting arcing could cause the batteries to explode.

Failure to unplug AC power before moving or driving equipment will result in damage to cords, plugs, receptacles, charger and batteries.

Battery/Charger Information

BATTERY SAFETY & CARE INFORMATION:

Always wear protective eye shields and clothing when working with batteries. Batteries contain acids which can cause bodily harm. Do not put wrenches or other metal objects across the battery terminal or battery top. Arcing or explosion of the battery can result. Do not wear jewelry when working around batteries. Arcing can cause severe burns.

The tops of the batteries and battery hold downs must be kept clean and dry at all times to prevent excessive self discharge and flow of current between the battery post and frame.

Do not over discharge batteries. Excessive discharge can cause polarity reversal of individual cells resulting in complete battery failure. Re-charge batteries as soon as possible after a deep discharge, but not if they are warm, allow a cooling down period.

Provide adequate ventilation when charging batteries. Chargers can ignite flammable materials and vapors. Do not use near fuels, grain, dust, solvents, or other flammables.

Do not charge batteries in excessively hot temperatures; wait till the cool of the evening.

PRE CHARGE INFORMATION:

Allow space for the charger to dissipate heat, it will get hot while in use. Do not seal the charger in an air tight compartment. Do not cover the charger with any material. **NOTE:** The OB models are NOT water proof, they are water resistant. This means they cannot withstand immersion, or continuous exposure from pressure washers, or heavy rain.

Connect the red charge lead to battery positive, black to negative. But before, make sure the battery pack is of the same voltage rating of the charger. If you are unsure, count the number of cells on the battery pack and multiply by two. This figure should be the same as the DC voltage rating of the charger. (see ratings label on charger) Charging a battery with a lower voltage rating than the charger will cause damage to batteries, charger, and can create an explosive atmosphere.

Make sure the AC cord, DC output leads, terminals, connectors, or clamps are all in good working condition. Do not use the charger if there are any signs of stress or damage, or if wires are cut or have damaged insulation. Using this charger with any of these symptoms could result in a fire, property damage, or personal injury. Have a qualified service person make the necessary repairs. Repairs should not be made by people who are not qualified.

Illustration of series and parallel battery connections:

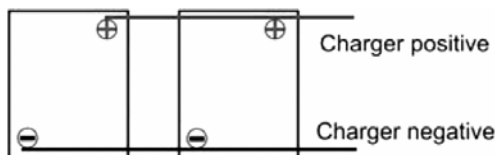

PARALLEL

When batteries are connected in Parallel the battery amp hour capacity is additive and the voltage remains the same.

Example: Two 180 amp hour 12 volt batteries would equal 12 volts and 360 amp hour capacity.

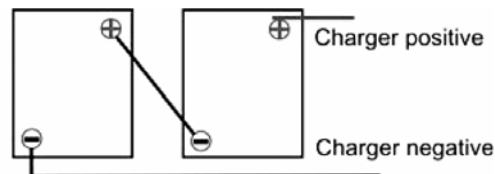

SERIES

When batteries are connected in Series the voltage is additive and the battery amp hour capacity remains the same.

Example: Two 180 amp hour 12 volt batteries would equal 24 volts and 180 amp hour capacity.

Battery/Charger Information

COMMONLY ASKED QUESTIONS

- Question:** When the charging battery has not been fully discharged will it take a memory set?
Answer: No, the design of these batteries allow charging at any stage of discharge without memory problems.
- Question:** Do I lose a complete cycle when I charge batteries that are only partially discharged?
Answer: No when 70% or higher useable charge in left. If below 70%, cycle will be used.
- Question:** Does the battery slow down as it discharges?
Answer: No, this design will give full power to 90% of the battery cycle. This drop off in the last 10% allows extra time to get back to your charger or extra packs
- Question:** Can the battery spill?
Answer: No, unlike other batteries, there is no liquid to spill out which allows for high shock load applications.
- Question:** Will batteries go dead?
Answer: No, the battery design will hold up to 90% of its' charge up to 2 years without being used or charged.
- Question:** Does severe cold effect the batteries?
Answer: If fully charged, no. If allowed to warm up (room temperature) battery will perform better. If battery is under 75% charge, severe cold will destroy the battery.
- Question:** Do I have to let batteries cool down after charge?
Answer: No, but if you do, you will get more life out of the battery.
- Question:** Can the battery overheat and discharge gases?
Answer: Yes, if improper charge is used or the battery heats to over 125° FH, gases off the vents inside of the batteries is possible. Caution must always be taken when charging batteries. Charge in a good ventilated area, away from sparks and open flame and away from bystanders.
- Question:** Can I leave the charger on too long?
Answer: No, our charging system is designed to read batteries state of charge constantly if left on for long periods of time (over the weekend) it will not hurt batteries or cause over charging problem.
- Question:** Can I leave the charger running while I am running the machine?
Answer: No, the charger must be unplugged from the power supply before using.

Battery/Charger Information

TROUBLESHOOTING

Symptom	Cause	Corrective Action
When plugged into AC power the LED flashes red/green.	Connected reverse to battery, or not connected to battery.	Correct polarity, or connect to battery.
	Break in DC cord, or connector.	Have a qualified person make repair.
	Battery too dead to charge.	Replace.
When plugged into AC power the LED does not come on.	No AC power.	Check circuit.
		Check extension cord for breaks or damage.
When I put a volt meter across the output of the charger there is no power coming out when I plug it in.	The charger must be connected to a battery to turn on.	Connect the charger to the battery.
The batteries don't receive a full charge.	The charger is too small for the battery.	Check that the charger's output is about 10% of the amp hour rating of the battery.
	The charge profile is not set correctly.	Recheck the dip switch setting. If in doubt, contact us.
	The cycle needs more time.	If you have a 4 position switch, switch #1 position ON.
	The battery is defective.	Replace.
When switched on, the LED flashes red/yellow.	Charger and battery voltage mismatch.	Connect the charger to a battery(s) with the same voltage rating.
When powered up the LED is solid red with a yellow flash.	The battery is very low, and the charger is in a slow charge phase until the voltage rises to a safe level before full turn on.	Leave connected, it may take hours, but if the voltage rises even a little bit, it should recover and turn the charger full on. <i>(Do not allow your batteries to deep discharge, it is the number one cause of premature battery failure.)</i>
The charger blows it's fuse, or branch circuit fuse/circuit breaker as soon as it's switched on.	Charger is shorted.	Contact factory.
The charger blows the branch circuit fuse/circuit breaker a short while after being switched on.	The branch circuit is too small.	Relocate charger to a branch circuit with a heavier rating, or remove other loads on the circuit.
After a full charge, the batteries die quickly.	The batteries are sulfated.	Sometimes batteries can be recovered. Leave the charger on for some hours, if the voltage falls and the current begins to rise, it is a good sign they can recover under normal charging.
All other issues		Please call National and speak with a technician.

Machine Operation

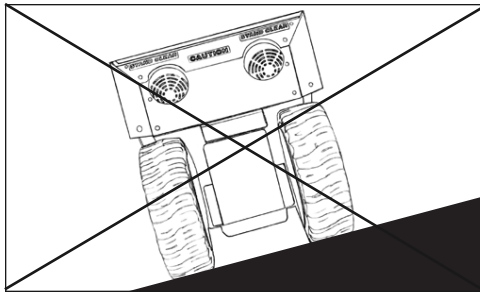

FIG. A

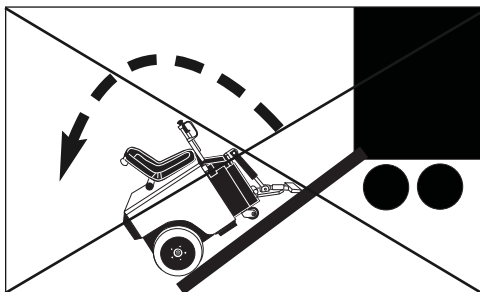

FIG. B

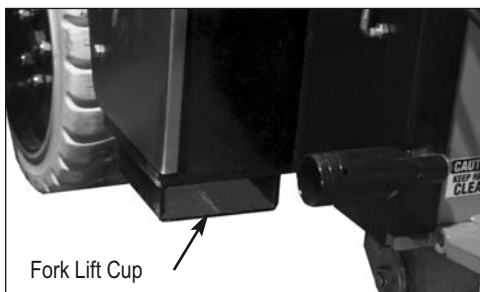

FIG. C



FIG. D



FIG. E

LOADING/UNLOADING

SAFETY PRECAUTIONS

- Always remove blade and cutting head when machine is being moved or transported
- Cutting head and slide plate can be removed to make the machine more compact.
- NEVER leave machine unattended on an incline.
- Removing added weights help to make the machine easier and safer to move in and out of a vehicle.

WARNING: MACHINE HAS A SWIVEL FRONT CASTER. NEVER SIDE HILL (FIGURE A). THE MACHINE ON A INCLINE WITHOUT POWER, THE FRONT CASTER WILL CAUSE MACHINE TO SWING TO THE LOWEST POINT. IF IT IS NECESSARY TO RUN MACHINE ON AN INCLINE, RUN MACHINE ON CUTTING HEAD. PLACE AT LEAST A 8" CUTTING HEAD IN MACHINE. TO KEEP FROM DAMAGING FLOOR, CLAMP A PIECE OF CARPET INTO CUTTING HEAD TO SLIDE ON THE FLOOR. THIS WILL GIVE POSITIVE CONTACT WITH THE FLOOR WHEN POWER IS DISENGAGED FROM THE WHEELS.

DOCK HEIGHTS

It is best to load or unload the machine from a level/equal dock height (a van from a van dock height, a truck/semi from a regular dock height).

POWER-GATE

A power-gate can be used when the dock height is not available. Make sure gate is properly rated for 3000 lbs. Make certain the machine is secure so it does not roll off the power-gate. To better secure machine, raise machine onto the lowered cutting head, raising machine off the caster. Tie machine down, chock wheels.

RAMPS

CAUTION: MACHINE IS BACK HEAVY. DO NOT RUN ON STEEP INCLINE THIS COULD CAUSE MACHINE TO TIP OVER! (FIGURE B)

To be safe, the ramp needs to be very long to accommodate the machine being loaded/unloaded. Remove added weight. Do not have at a steep incline. The use of a power winch or hand come-a-long is much safer. For a van, the ramp should be 12 to 18 feet in length depending on the depth of the incline. For truck height taller than a van, longer ramps will be needed. See OSHA guidelines. It is not recommended to drive the machine, connected with power, on a ramp. Make sure ramp is secure and has good contact before using. Failure to do so could cause ramp to fall away from the vehicle.

FORKLIFT CUPS

There are two forklift cups mounted under the front of the machine (Figure C). Slide fork lift forks through forklift cups. Slide forks all the way back to touch the rear tire (Figure D). Before lifting machine, secure machine to fork lift with heavy 3000 lb. or heavier rope or chain. Tilt forks back to lift machine Figure E).

WINCHES

Winches should be used for safety when loading or unloading with ramps. 3000 lb. winch minimum.

TRANSPORTING

Secure machine down with ratchet straps when transporting the machine. Chock wheels to keep machine from rolling, hydraulic levers should **not** be locked in the forward or

Machine Operation

backward position. Hydraulic levers should be straight up in the "neutral" position. This helps to lock drive wheels. Lift machine off swivel caster by lowering cutting head for better stabilization. Proper securing straps need to be rated at least twice the weight of the machine.

WHEEL CHOCKS

Wheel chocks will help to secure the machine but DO NOT use wheel chocks alone to secure the machine.

PALLETIZING

Only use a solid platform pallet. If a solid platform pallet is not available, place a piece of $\frac{3}{4}$ " plywood on top of a pallet. Using a forklift with the forks inserted in the forklift cups, place machine on pallet. Use ratchet straps to secure machine to pallet.

CENTER OF GRAVITY

Be aware of your surroundings and machines operating angles. When changing from a low slide plate to a high slide plate setting or a low cutting head angle to a high cutting head angle, the operating "attitude" of the machine changes. When a floor surface is not level (ramps, inclines, large amounts of debris which would lift the drive wheel of the machine, etc.), the center of gravity changes. Too much of an angle could make the machine unsafe (a cause for tip-over). **Do Not** run the machine in unsafe environments.

JOB SITE MOVEMENT

TAPING WHEELS

Taping the wheels with a wide like masking tape helps to prevent damage and dirt to floors during move-in and move-out.

LEAP FROGGING BOARDS

Leap frogging boards help to protect floors from damage. Use two or three $\frac{1}{4}$ " luan or plywood sheets, approximately 27" wide by 6' long. Cover one side of the board with a thin carpet. With the carpet side to the floor, place a board in front of the machine. Drive onto the board. Set the next board in front of the machine. As you drive off one board, pick it up and set it in front of the machine.

FRONT WHEEL ASSEMBLY (FIGURE I)

To use the Front Wheel Assembly raise slide plate so the bottom of the slide plate is higher or even with the bottom of the guide channels, 6" to 8" is ideal. Raise cylinder, insert Front Wheel Assembly into cutting head. Secure with securing pin. Caster wheel should swivel freely and the Front Wheel plate should be parallel with the floor.

TO MOVE MACHINE WITHOUT POWER (PUSHING MACHINE)

Forward: To move the machine forward, levers need to be pushed forward. To lock levers in place, connect a bungee-strap from each lever (pushing levers forward), pulling straps down to and connecting to the front plate (Figure J). Never leave machine unattended with strap holding levers open.

Backward: To move machine backward, levers need to be pulled backwards. To lock levers in place, connect a bungee-strap from each lever (pushing levers backward), Pulling straps to the back of the machine and connecting behind the seat or the rear of the machine (Figure K). Never leave machine unattended with strap holding levers open.

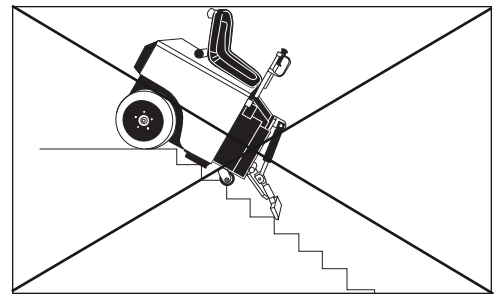

FIG. F

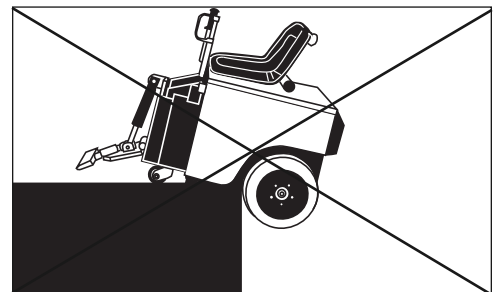

FIG. G

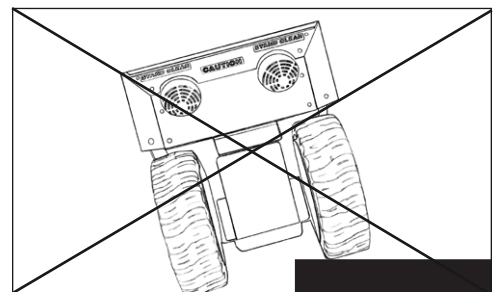

FIG. H

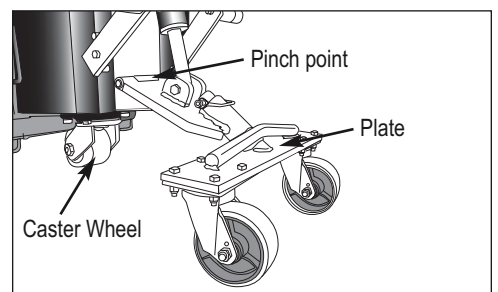

FIG. I

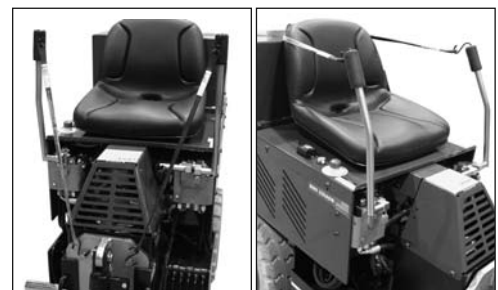

FIG. J

FIG. K

CAUTION: ALWAYS REMOVE STRAPS BEFORE STARTING MOTOR. FAILURE TO DO SO WILL MAKE MACHINE MOVE AND MAY CAUSE PROPERTY DAMAGE AND/OR BODILY INJURY.

Machine Operation

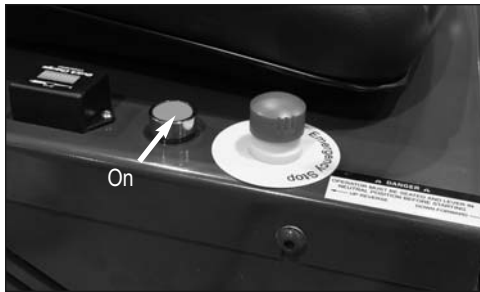

FIG. A



FIG. B



FIG. C

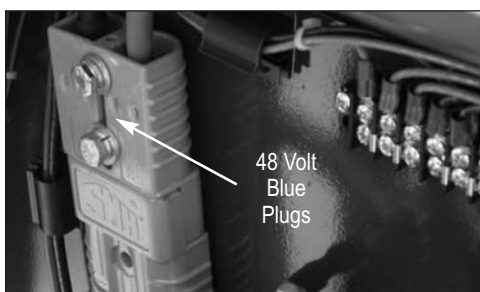

FIG. D

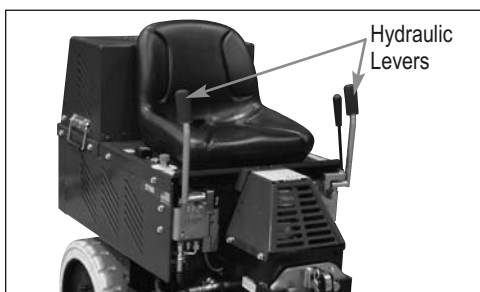

FIG. E

OPERATING CONTROLS

WARNING: NEVER OPERATE MACHINE WITHOUT PUMP GUARD HOUSING IN PLACE.

POWER ON SWITCH (FIGURE A)











Never use the power on/off switch as a method for speed control. Speed control is achieved by the hydraulic valve only. Using the on/off switch repeatedly will cause excessive wear, causing premature replacement of electrical components. An Emergency Stop Switch (E-Stop) is located by right hand (Figure B). To start machine, twist the E-Stop until it pops up. There is a seat safety switch. The operator must be properly seated for machine to operate. Push the on/off button to start machine.

MACHINE START-UP PROCEDURE

- Verify 70 amp circuit breaker is in "On" position (Figure C)
- Verify 48-volt blue plugs are firmly connected (Figure D)
- Operator should be properly positioned on seat
- Twist E-Stop (Figure B) to "up" position exposing green ring
- Push green "on" button
- Maneuver machine with hydraulic levers (see instruction below)

HYDRAULIC LEVERS (FIGURE E)

The hydraulic levers steer the machine. For smooth even movement, always move levers slowly. Fast movement of control levers will result in jerky, uneven movement.

- Move levers slowly.
- Both levers forward   move the machine forward.
- Both levers backward   move the machine backward.
- The left lever forward and the right lever backward   turn the machine quickly to the right.
- The left lever backward and the right lever forward   turn the machine quickly to the left.
- Only using the left or right lever forward , turns the machine slowly to the right or left.
- Only using the left or right lever backwards , turns the machine slowly to the left or right.
- Correcting direction while moving forward is accomplished by slightly reducing pressure on one lever or the other while moving.
- The center position on levers causes wheels to lock-up.
- Always chock wheels and tie down machine when transporting.

Control levers are low in vibration.

EMERGENCY STOP SWITCH (FIGURE B)

The emergency stop switch is designed to kill the power to the system.



SEAT SWITCH

The seat has a safety switch. Operator must be properly positioned for machine to run.

TO STORE MACHINE (FIGURE D)

When the machine is in storage, remove the blue plug and turn circuit breaker to off. This will help to keep someone from operating the machine when it shouldn't be.

CYLINDER LIFT (FIGURE F)

The cylinder lift lever raises and lowers the cylinder and cutting head. After setting slide plate to proper height, use the cylinder lift lever to set blade to proper cutting angle. Pull back  on the cylinder lift lever to raise the cutting head. Push the cylinder lift lever forward  to lower the cutting head. Continuing to push the cylinder lift lever forward and it will adjust the angle of the cutting head. This will also jack up the front of the machine (Figure B). This will need to be done when doing maintenance on the machine (ie: wheel changing, front caster maintenance etc). When doing machine maintenance, besides raising the cutting head angle, place blocks under the machine (Figure C). Never use the cutting head only.

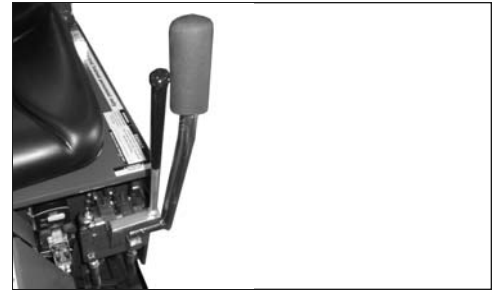

FIG. F

WARNING: DO NOT ALTER A SWITCH OR LEVER. DO NOT DEFEAT A SAFETY DEVICE.

WARNING: DISARM MACHINE BY REMOVING THE CUTTING HEAD OR DROPPING THE CUTTING HEAD TO THE FLOOR WHEN THE MACHINE IS NOT IN USE.



FIG. G

OPERATIONAL TIPS

CASTER

Keep clean and free of debris, make sure it can move freely. Clean as needed. Inspect before each use. Grease once a month.

Moving a "weighted" machine only on the front caster and not on the cutting head or the Front Wheel Assembly can seem to make the machine turn sluggish. It might turn hard to the right or the left. This is normal.

FOOT PEG

Keep feet resting and secured on foot pegs when operating machine. Foot pegs are adjustable. Make sure securing nut is securely tightened

SEAT

Always be properly seated before operating machine. Machine will not run if the operator is not properly seated

DISARM MACHINE

Remove blade or drop cutting head to the floor when machine is not in use.

LEAKAGE

Keep fittings and hoses tight. If a leak is noticeable, retighten fitting. If leakage persists, remove the connection and inspect.

ANGLE OF THE HEAD IS SET STEEP

When raising the front of the machine to a steep angle, the bottom of the slide plate should be raised so it is higher or even with the bottom of the guide channels, 6" to 7" off the floor. This will allow for a steep blade angle without tipping the machine too far back and is usually used for re-scraping. The most common mode for take up has the slide plate approximately (1") one inch from the floor.

RAISING OR LOWERING THE SLIDE PLATE

This will only work without a cutting head inserted in the machine. Completely loosen slide plate bolts. Use cylinder lift lever to raise or lower machine to move slide plate up or down.

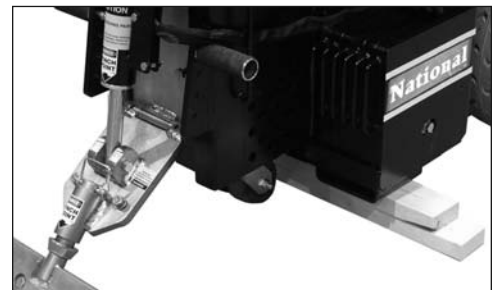

FIG. H

Machine Operation

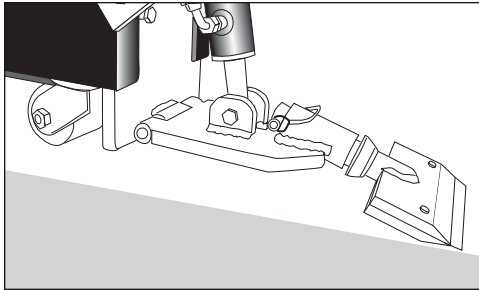

FIG. A

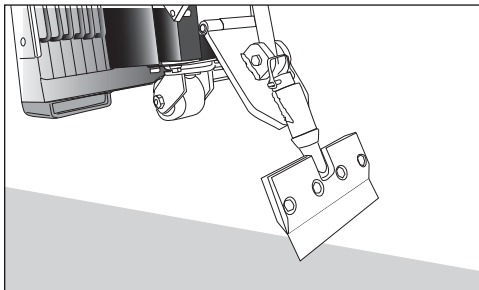

FIG. B

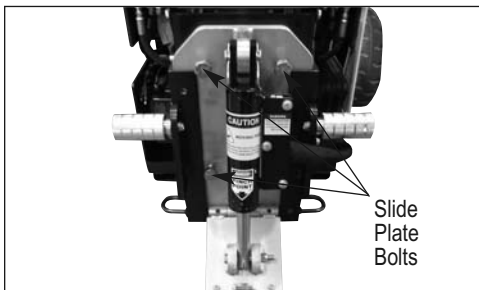

FIG. C

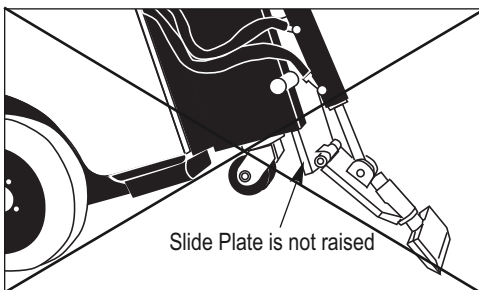

FIG. D

DIALING IN THE MACHINE

Dialing in the machine is matching the correct cutting head, blade size, blade angle and blade width to the machine to make the material removal as easy as possible. For every material being removed, there is an optimum blade width, thickness, sharpness, angle and bevel (bevel up or bevel down).

ADJUSTING THE MANUAL SLIDE PLATE AND CUTTING HEAD (FIGURE A & B)

Caution: Pinch point. When adjusting slide plate, keep feet and hands out from underneath the cutting head and slide plate. Failure to do so could cause severe bodily injury. When bolts are removed from the slide plate, the cutting head and the slide plate will drop down to the floor.

- Loosen the four bolts on the front of the slide plate with a 1-1/8" wrench (Figure C).
- Slide plate up or down to achieve the desired height of the cutting head.
- A low setting orients the slide plate approximately 1" off the floor. This is for normal removal of most materials.
- A high setting orients the slide plate approximately 6" off the floor. This is for re-scraping glue and some thin-soft coatings.
- Firmly retighten both bolts.

ADJUSTING THE DUAL LIFT SLIDE PLATE AND CUTTING HEAD

- For safety prior to adjusting the dual lift hydraulic slide plate make sure the channel guide is free of any debris and the machine is safely positioned on a flat surface.
- Be properly seated in the operator's seat.
- Twist the Red Emergency Stop switch located on the right side of the operator, the spring-loaded switch will pop up when twisted.
- Push the Green 'ON' button to start the machine.
- Adjacent to the left hand steering lever is a straight and narrow handle rod, this handle rod raises and lowers the front cylinder and is referred to as the 'cutting head lever'. To set the height of the hydraulic slide plate start by first adjusting the angle or pitch of the cutting head holder.
- Pull back on the cutting head lever and raise the cutting head holder to an angle higher than the bottom of the slide plate.
- Using the lever adjacent to the right hand steering lever raises and lowers the hydraulic slide plate and is referred to as the 'slide plate lever'. To lower the slide plate the operator must push forward on the slide plate lever. Reversely, to raise the slide plate the operator must pull back on the slide plate lever.

While the hydraulic slide plate can be adjusted to multiple positions there are two basic slide plate settings.

- **Low Setting:** the hydraulic slide plate is positioned 1" off the floor. This setting is most commonly used during initial scraping or removal applications; such as carpet, VCT, ceramic tile and wood flooring. (Note: The "low" setting on older model hydraulic slide plates may stop the plate within one to two inches of the floors surface.)
- **High Setting:** the hydraulic slide plate is positioned 6" off the floor or in most cases flush with the bottom of the slide plate channel guide. This setting is most often used for re-scraping glues, mastics, thin sets and soft coating.

SHEAR POINT

The shear point is the point where material to be removed will cut cleanly from the floor. If the blade is too wide, too dull, or too steep, the shear point is lost.

WEIGHT VS. SHARPNESS

The most common way to compensate for a dull blade is to add more weight and raise the blade angle (see high setting). Weight allows dull blades to be used to a point. Weight also causes blades to dull and break easier. Blades of any thickness tend to catch cracks and expansion joints and will bend or break the blade if set at a high angle. For best results, run a small ditching blade at a low angle to identify as many cracks and joints as possible. If blades are breaking, you are misunderstanding the conditions.

CUTTING HEAD ANGLE

Set the cutting head angle to where the material comes up the easiest. Start with a lower angle setting and raise slightly as the blade wears to maximize the shear point.

STEEP CUTTING HEAD ANGLE

A steep angle is only used for re-scraping. The slide plate has to be raised so the bottom of the slide plate is higher or even with the bottom of the guide channels (Figure B). Not raising the slide plate when operating the machine at a steep angle will cause the machine to jump and buck. It does not give the operator a clear vision of the cutting head and it raises the machine to operate at a unsafe operating height (Figure D). Failure to raise the slide plate could cause machine damage and/or bodily injury.

SWIVEL HEAD

The swivel head keeps the blade in contact with the floor even when the floor is uneven. When using a flat blade, by swiveling the head over 180° allows another sharp edge on the blade without having to replace the blade.

CUTTING HEAD INSERTION

With machine off, insert desired cutting head into cutting head holder. Secure with cutting head clip.

SAVING TIME WITH EXTRA CUTTING HEADS

The machine is supplied with one cutting head. Having additional cutting heads will save time on the job. Insert blades into the extra cutting heads before starting a job. When the blade is dull, instead of taking the time to replace it or sharpen it on the job, take out the cutting head and replace it with another. Or when a different type or size of blade is needed, you have them ready to use.

Machine Operation

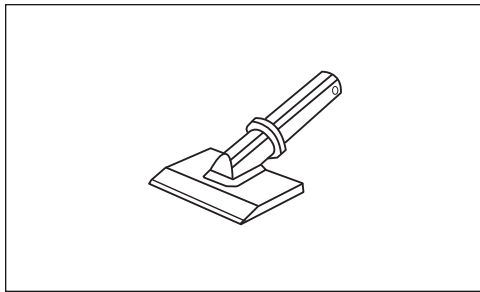

FIG. E

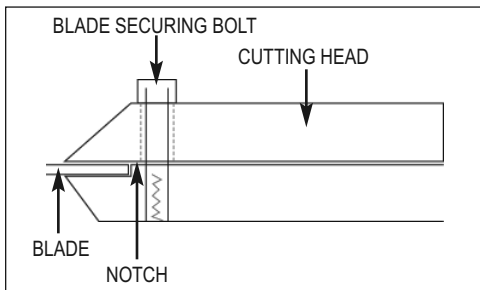

FIG. F

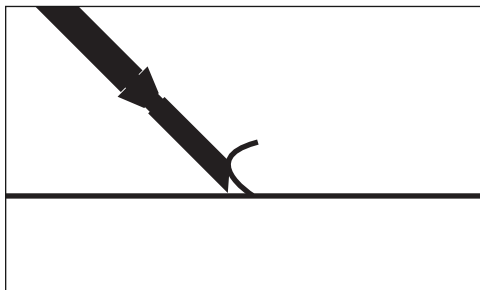

FIG. G

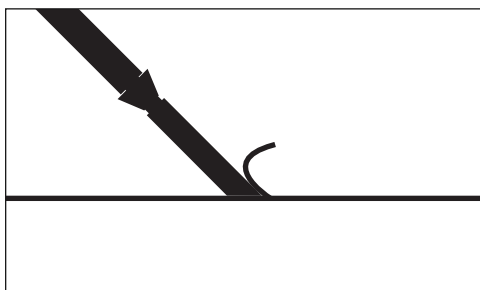

FIG. H

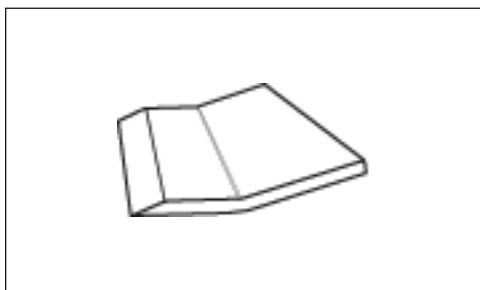

FIG. I

SHANK BLADE INSERTION

Shank blades (Figure E) do not require a cutting head. Insert desired shank blade into cutting head holder. Secure with cutting head clip.

BLADE INSERTION OR BLADE CHANGING (FIGURE F)

Using a 3/4" socket wrench, loosen bolts on cutting head. Quantity of bolts will vary depending upon cutting head size. Insert blade into the cutting head to back of notch (Figure A). Tighten firmly. **Note:** A cordless 3/8" drive impact wrench will speed up this process especially out on the job.

WARNING: ALWAYS WEAR GLOVES WHEN HANDLING BLADES

BLADE SETTING

- Proper blade size and placement, depending on material and sub-floor type, affects performance.
- The harder a job comes up, for best results, use a smaller blade.
- Start with a narrow blade, then increase blade size to optimize cutting pass. Narrower blades work easier than wider blades and usually clean the floor better. Wider is not always better or faster.
- Normally bevel on blade is up for concrete (Figure G). Bevel down for wood (Figure H) and shoe blades (Figure I) for soft sub-floors.
- KEEP BLADES SHARP.
- Dull blades greatly affect the performance of the machine and reduce cutting ability, sharpen or replace as needed.
- Keep your work area clean and clear of debris.
- After you have removed a portion of material, remove it out of the way. This will give the machine maximum performance and help to keep the work area safe.
- Always wear gloves when handling blades.
- Everyone in work area should wear eye protection.

SELF-SCORING BLADES

Instead of pre-scoring a job, for soft goods (carpet, vinyl, linoleum, membrane) the self-scoring blades automatically do the scoring.

APPLICATION SET-UP

CERAMIC SET-UP (FIGURE A)

The slide plate should be adjusted to a low setting (1") on inch off the floor. Use a Shank Blade or a Shank Blade with a carbide tip.

WOOD SET-UP (FIGURE B)

CAUTION: BLADES ARE SHARP; USE EXTREME CAUTION WHEN HANDLING.

CAUTION: NEVER CHANGE CUTTING HEAD OR SERVICE BLADES WHILE MACHINE IS RUNNING.

WARNING: DISARM MACHINE WHEN IT IS NOT IN USE. REMOVE THE CUTTING HEAD OR DROP CUTTING HEAD TO THE FLOOR. FAILURE TO DO SO COULD CAUSE BODILY INJURY.

Machine Operation

The slide plate should be adjusted to a low setting (1") one inch off the floor. Use Shank Blades, Shank Blades with carbide tips or a 6" or 8" Cutting Head with Shoe Blades, Bent Shoe Blades or Heavy Duty Blades. **Note:** Run machine 45° to the grain of the wood.

SECONDARY BACKING CARPET SET-UP

The slide plate should be adjusted to a low setting (1") one inch off the floor. Use a Cutting head from 10" to 27" with Heavy Duty Blades or a Cutting Head from 10" to 14" with a Self-Scoring Blade.

FOAM BACK CARPET SET-UP

The slide plate should be adjusted to a low setting (1") one inch off the floor. Use Cutting Heads from 10" to 14" with Self-Scoring Blades (Figure C). If it is not stuck tight, use a Cutting Head from 14" to 27" with a Standard Blade.

DOUBLE STICK CARPET SET-UP

The slide plate should be adjusted to a low setting (1") one inch off the floor. It is best to test to see which is the easiest way to remove double stick. Start with a Cutting Head from 10" to 14" with Self-Scoring Blades (Figure C). If self-scoring blades do not work, score thru the carpet (Figure D) the width of the blade (Standard Blade) and scrape up. In some cases, carpet might pull off the pad and then scrape up the pad separately. Usually leaving carpet connected to the pad works the best. Sharp blades are necessary for proper operation.

Note: When removing carpet from over VCT Tile and the tile needs to be saved, run the machine at a 45° angle over the tile. This should help to save the tile.

VCT TILE SET-UP

The slide plate should be adjusted to a low setting (1") one inch off the floor. If goods come up easily, change to a larger Cutting Head. If goods come up harder, use a Cutting Head from 6" to 8" with a Premium High Tempered Blade (.062) to match cutting head size. Sometimes a .094 blade may work better. If goods remove easily, a Tile Box #7074 can be used. A tile box also works for wind rowing, assists for a fast clean-up and collection of tile debris for quick removal.

RUBBER TILE SET-UP

The slide plate should be adjusted to a low setting (1") one inch off the floor. Use a Cutting Head from 6" to 14" with self-scoring blades or use ditching method with a flat blade.

RE-SCRAPING SET-UP

Slide plate should be set high, 6" to 8" off the floor. Use a Cutting Head from 8" to 27" with Scraper Blades to match cutting head size. A 15" scrapper blade would use a 14" Cutting Head. Razor Blades are faster but a Cutting Head from 8" to 14" can be used with a Standard Blade. Flip head regularly.

THIN COATING SET-UP

Slide plate could be set high, 6" to 8" or low 1" off the floor. Test to see which works best. Use a Cutting Head from 8" to 27" with Razor Blades to match cutting head size.

WORKING OVER CONCRETE

Blade should be bevel up when working over concrete. Pretty much anything over concrete works. Try different set-ups to see which works best. If goods come up difficult, the slide plate should be at a low setting, 1" off the floor. Use a smaller size blade. If goods come up easily, a wider blade can be used.

WORKING OVER WOOD

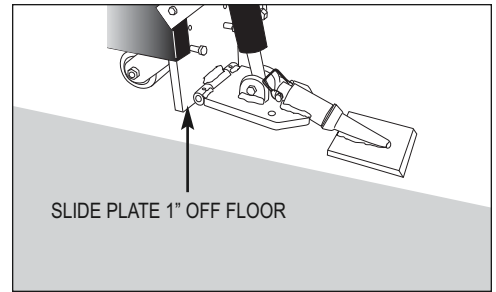

FIG. A

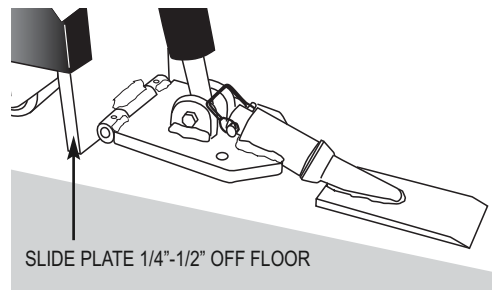

FIG. B

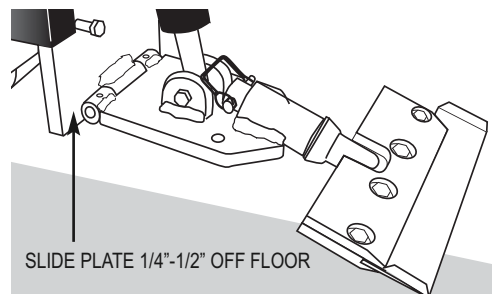

FIG. C



FIG. D

Machine Operation

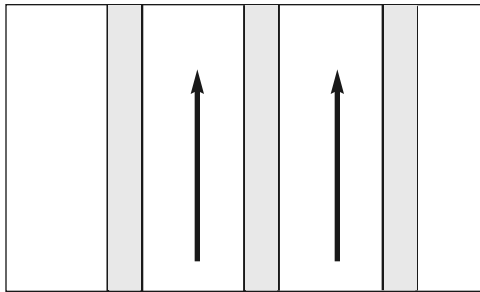

FIG. E

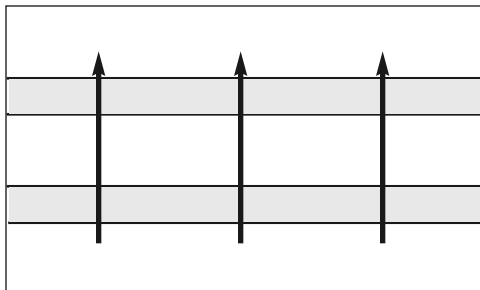

FIG. F

A heavy machine cannot be used on wood subfloors or raised panel computer floors. Keep machine light, remove all weights. A weighted machine could break through the floor. The slide plate should be adjusted to a low setting (1") on inch off the floor. Blades should be as flat of an angle as possible. Use a "shoe blade", Extra Heavy Duty Blade (these blades have a bend to them) or a regular blade, bevel up. When using a regular blade, bending up the corners of the blade will help from the blade digging into the floor. Sometimes a shank blade or a shank blade with a carbide tip will work. Allow blade to shear material from the floor. The trick on wood floors is to run the blade flat. Approach should be at a 45° angle to the board. This keeps from digging into the board and hanging up at the seams.

WORKING OVER SOFT SUB-FLOOR

The slide plate should be adjusted to a low setting (1") one inch off the floor. Blades should be as flat of an angle as possible. Use a "shoe blade", Extra Heavy Duty Blade (these blades have a bend to them) or a regular blade, bevel up. When using a regular blade, bending up the corners of the blade will help from the blade digging into the floor. Sometimes a shank blade or a shank blade with a carbide tip will work.

DITCHING

CROSS ROOM DITCHING

When removing hard to remove ceramic, VCT--- or vat, cross-room ditching will help to make the removal easier. Using a blade 2" to 6" in width, make ditches 1' to 2' apart in the same direction the machine will be removing the goods (Figure E). This "relieves" the pressure holding the tiles together. If ditching helps and the goods are coming up easy, try using a wider blade to ditch with.

CHECKER BOARD DITCHING

To make carpet removal and debris cleanup easier, checker board ditching is very helpful. Using as wide of a self-scoring blade as possible, make ditches 4' to 6' apart crossways from the way the machine will be removing the goods (Figure F). Running the machine crossways from the ditches will make smaller pieces of debris to be hauled away. Instead of large gummy rolls of carpet, there are small squares that can be rolled, palletized, put on a dolly or folded with the sticky side in. This makes removing the debris easier and reduces the amount of debris.

▲ **CAUTION:** BLADES ARE SHARP; USE EXTREME CAUTION WHEN HANDLING.

▲ **CAUTION:** NEVER CHANGE CUTTING HEAD OR SERVICE BLADES WHILE MACHINE IS RUNNING.

▲ **WARNING:** DISARM MACHINE WHEN IT IS NOT IN USE. REMOVE THE CUTTING HEAD OR DROP CUTTING HEAD TO THE FLOOR. FAILURE TO DO SO COULD CAUSE BODILY INJURY.

CUTTING HEADS (FIGURE A)

Swivel heads rotate to use the second sharp edge of the blade without having to remove the blade. Swivel head allows blade to stay in contact with the floor.

PART#	DESCRIPTION
7050-6	6" CUTTING HEAD
7050-8	8" CUTTING HEAD
7050-10	10" CUTTING HEAD
7050-12	12" CUTTING HEAD
7050-14	14" CUTTING HEAD
7050-27	27" CUTTING HEAD

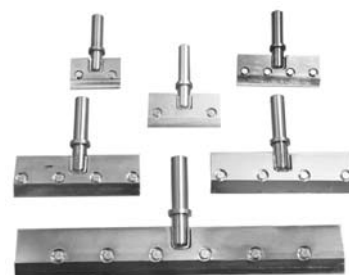

FIG. A

TYPES OF BLADES

STANDARD BLADES (FIGURE B)

PART#	DESCRIPTION	THICKNESS (IN.)
135	5" X 16" BLADE	.062
147	4" X 6" BLADE	.062
148	5" X 6" BLADE	.062



FIG. B

PREMIUM HIGH TEMPERED BLADES (FIGURE C)

Ultra high quality spring steel is extra hard for long blade life between sharpening. Works on all glued down carpets, VCT, VAT, rubber tile, cork, re-scraping adhesive, elastomeric coatings. Great for floor accumulations.

PART#	DESCRIPTION	THICKNESS (IN.)
7050-200	3" X 6" PREMIUM HIGH TEMPERED BLADE	.062
7050-201	3" X 8" PREMIUM HIGH TEMPERED BLADE	.062
7050-202	3" X 10" PREMIUM HIGH TEMPERED BLADE	.062
7050-203	3" X 12" PREMIUM HIGH TEMPERED BLADE	.062
7050-204	3" X 14" PREMIUM HIGH TEMPERED BLADE	.062
7050-205	3" X 27" PREMIUM HIGH TEMPERED BLADE	.062



FIG. C

HEAVY DUTY BLADES (FIGURE D)

A heavy duty blade that still has a little flex. Made with National's proven blade hardening process, these blades will stay sharper longer with better overall performance than any other blade on the market. Works on VCT, VAT, wood, tile, rubber, epoxy, elastomeric coatings, scraping thin-set, glued ceramic.

PART#	DESCRIPTION	THICKNESS (IN.)
6281	3" X 8" HEAVY DUTY BLADE	.094
6282	3" X 14" HEAVY DUTY BLADE	.094
6283	3" X 27" HEAVY DUTY BLADE	.094
6284	3" X 12" HEAVY DUTY BLADE	.094
6285	3" X 6" HEAVY DUTY BLADE	.094
6286	3" X 10" HEAVY DUTY BLADE	.094
6240	4" X 6" HEAVY DUTY BLADE	.094
6241	4" X 8" HEAVY DUTY BLADE	.094
6242	4" X 12" HEAVY DUTY BLADE	.094
6243	4" X 15" HEAVY DUTY BLADE	.094
6244	4" X 24" HEAVY DUTY BLADE	.094
6245	4" X 10" HEAVY DUTY BLADE	.094
6246	4" X 27" HEAVY DUTY BLADE	.094



FIG. D

Blades



FIG. E

EXTRA HEAVY DUTY BLADES (FIGURE E)

Extremely hard, high abrasion alloy for tough tear up situations. VCT, VAT, wood, tile, lighter ceramic, rescraping thin-set, all carpets, cork, elastomeric coatings, rescraping rubber and urethane coatings. Holds the edge extremely well.

PART#	DESCRIPTION	THICKNESS (IN.)
6290	3" X 6" EXTRA HEAVY DUTY BLADE	.187
6291	3" X 8" EXTRA HEAVY DUTY BLADE	.187
6292	3" X 12" EXTRA HEAVY DUTY BLADE	.187
6293	3" X 14" EXTRA HEAVY DUTY BLADE	.187
6294	3" X 27" EXTRA HEAVY DUTY BLADE	.187



FIG. F

STRAIGHT SHANK BLADES (FIGURE F)

Works well for ceramic, wood and thick epoxy. The ultimate for the toughest removals. Made from an ultra-tough alloy, which is put through special processing to give these blades unbelievable edge holding ability for ceramic epoxy, thin- set, mud set, decorative concrete toppings and much more.

PART#	DESCRIPTION	THICKNESS (IN.)
7070-2	4" X 2" STRAIGHT SHANK BLADES	.500
7070-3	4" X 3" STRAIGHT SHANK BLADES	.500
7070-4	4" X 4" STRAIGHT SHANK BLADES	.500
7070-6	4" X 6" STRAIGHT SHANK BLADES	.500



FIG. G

ANGLE SHANK BLADES (FIGURE G)

Works well for ceramic and thick epoxy. The same application as the #7070 blades, but is mounted at an angle to achieve the optimum shear point for optimum performance.

PART#	DESCRIPTION	THICKNESS (IN.)
7071-2	4" X 2" ANGLE SHANK BLADES	.500
7071-3	4" X 3" ANGLE SHANK BLADES	.500
7071-4	4" X 4" ANGLE SHANK BLADES	.500
7071-6	4" X 6" ANGLE SHANK BLADES	.500



FIG. H

STRAIGHT SHANK BLADES WITH CARBIDE TIP (FIGURE H)

Works well for ceramic and thick epoxy. The same application as the #7070 blades, but are carbide tipped for holding a sharp edge for long periods. Nothing else performs like carbide when no other blade will work. Works well on elastomeric coatings.

PART#	DESCRIPTION	THICKNESS (IN.)
7072-2	4" X 2" STRAIGHT SHANK W/CARBIDE TIP	.500
7072-3	4" X 3" STRAIGHT SHANK W/CARBIDE TIP	.500
7072-4	4" X 4" STRAIGHT SHANK W/CARBIDE TIP	.500
7072-6	4" X 6" STRAIGHT SHANK W/CARBIDE TIP	.500



FIG. I

ULTRA HEAVY DUTY CERAMIC EPOXY ANGLE SHANK BLADES WITH CARBIDE TIPS (FIGURE I)

Designed for ceramic removal and thin-set rescraping. 1/2" of carbide. The extra carbide allows for maximum resharp- ening. Strong enough to work on machines up to 3500 lbs.

PART#	DESCRIPTION	THICKNESS (IN.)
7079-2	2" X 6" ULTRA HD CERAMIC EPOXY BLADE	.500
7079-4	4" X 6" ULTRA HD CERAMIC EPOXY BLADE	.500
7079-6	6" X 6" ULTRA HD CERAMIC EPOXY BLADE	.500

TAPERED CUTTING HEAD SHANK BLADES (FIGURE A)

The longer taper works great on tough wood floors (glued & nailed). The long length allows the blade to easily slide under tough material. Works well on most ceramics and VCT.

PART#	DESCRIPTION	THICKNESS (IN.)
7075-8	2" X 8" TAPERED CUTTING HEAD SHANK	.300
7075-11	2" X 11" TAPERED CUTTING HEAD SHANK	.300
7077-8	3.5" X 8" TAPERED CUTTING HEAD SHANK	.300
7077-11	3.5" X 11" TAPERED CUTTING HEAD SHANK	.300



FIG. A

SELF-SCORING BLADES (FIGURE B)

Tough, long lasting, self-scoring blades. 90° angled self-scoring wings. Made from National's proven blade hardening process, performs up to ten times longer than the competition. Works on attached cushion, Unitary or secondary backing, vinyl back, soft to medium PVC, linoleum, carpet tiles, soft cork, Enhancer and Unibond hot melts.

PART#	DESCRIPTION	THICKNESS (IN.)
6257-BU	3" X 9" SELF-SCORING BLADE	.062
6258-BU	3" X 12" SELF-SCORING BLADE	.062
6259-BU	3" X 14" SELF-SCORING BLADE	.062
6260-BD	3" X 6" HEAVY DUTY DITCHING	.094
6276-BU	3" X 10" SELF-SCORING BLADE	.094
6277-BU	3" X 12" SELF-SCORING BLADE	.094
6278-BU	3" X 14" SELF-SCORING BLADE	.094
6279-BU	3" X 27" SELF-SCORING BLADE	.094
6247	4" X 10" SELF-SCORING BLADE	.094
6249	4" X 12" SELF-SCORING BLADE	.094
6248	4" X 24" SELF-SCORING BLADE	.094
6256-BU	4" X 6" W/ 4" BU SELF-SCORING BLADE	.062
6261-BU	3" X 12" W/ 4" BU SELF-SCORING BLADE	.062



FIG. B

INCREASED ANGLE BLADES (FIGURE C)

Mainly used for VCT, but can be used on most other applications. Supplies more of an angle when angle is needed. Prevents machine from jumping off material.

PART#	DESCRIPTION	THICKNESS (IN.)
7081	3" X 10" INCREASED ANGLE BLADE	.062
7083	3" X 8" INCREASED ANGLE BLADE	.062



FIG. C

RAZOR/SCRAPER BLADES (FIGURE D)

Razor sharp, super hard for scraping thin epoxies, thin mil coatings like urethane paint, poured elastomeric coatings up to 60 mil, hard to remove adhesives and much more.

PART#	DESCRIPTION	THICKNESS (IN.)
363-2	3/4" X 8" RAZOR/SCRAPER BLADE (50/PKG)	.032
368-8	7/8" X 8" RAZOR/SCRAPER BLADE (50/PKG)	.045
368-12	7/8" X 12" RAZOR/SCRAPER BLADE (50/PKG)	.045
368-15	7/8" X 15" RAZOR/SCRAPER BLADE (50/PKG)	.045



FIG. D

TILE BOX (FIGURE E)

Assists for a fast cleanup and collection of tile debris for quick removal. Can be used to remove easy to remove tile. Extremely high abrasion alloy for a long lasting edge. Edge can be re-sharpened.

PART#	DESCRIPTION	THICKNESS (IN.)
7074	5" X 27" TILE BOX WITH 6" HIGH BOX	.187



FIG. E

Blades

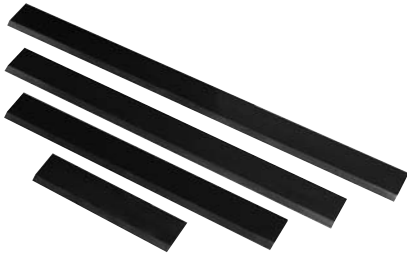

FIG. F

1" BLADES (FIGURE F)

Short profile blades where a rigid blade application is needed. Thickness greatly reduces breakage. Used for VCT & adhesive rescrapes. Works well for parking deck coatings, epoxies & elastomeric coatings.

PART#	DESCRIPTION	THICKNESS (IN.)
7091	1" X 4" BLADE	.094
7092	1" X 8" BLADE	.094
7093	1" X 10" BLADE	.094
7094	1" X 12" BLADE	.094

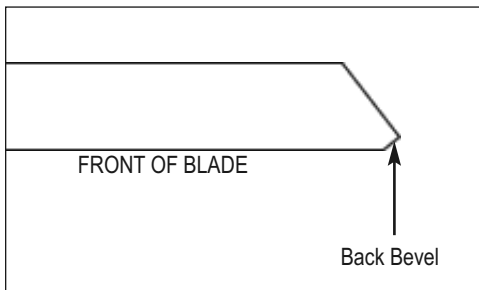

FIG. G

BLADE SHARPENING

Dull blades greatly reduce cutting ability. Re-sharpen or replace as needed. In use, blades develop a back-bevel (Figure G). When re-sharpening, blade will not be truly sharp until all back-bevel is gone.

Note: Thinner blades are easier to sharpen, but they also break easier.

- Always wear gloves and safety glasses.
- Grind blade using a 4" diameter disk with 120 or finer grit. Be careful not to catch disk on edge or corner of blade.
- Pass grinder along blade edge starting on one end and continuing in one direction being careful to hold grinder at proper angle of blade. Grind until sharp.
- Using a good quality fine tooth hand file, use same procedure as above.
- Blades are sharp. Use extreme caution.
- Have plenty of sharp blades on each job so on-the-job blade sharpening is eliminated.
- It is best to resharpen dull blades on proper bench or belt grinder in the shop, so the blades are ready for the next job.

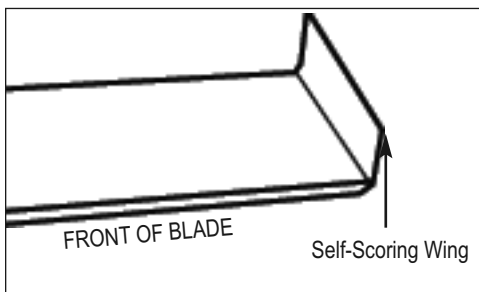

FIG. H

SELF-SCORING BLADE SHARPENING

It is important to keep the "wings" on a self-scoring blade sharp (Figure H). Use a file on the "wing" edge. Sharpen the flat part of the blade, the same way as described above.

CARBIDE TIPPED BLADE SHARPENING

To sharpen carbide tipped blades, a wheel to grind carbide is necessary, ie: silicon carbide or a green wheel.

▲

WARNING: ALWAYS DISCONNECT BATTERY BEFORE MAINTAINING.

MANUAL SLIDE PLATE REMOVAL

1. Disconnect machine from power.
2. Remove slide plate pin (A). Remove cutting head bolt (E). Remove cylinder from slide plate. Remove slide plate.

OR

1. Disconnect machine from power.
2. Unplug hydraulic lines from cylinder (F). A small amount of oil leak out of lines. Cap lines or bleed into a container. Wipe up spillage immediately.
3. With lines removed, loosen slide plate bolts (B). Hold slide plate at the top of the cylinder.
4. Remove slide plate, cylinder and lower cutting head support.

▲

CAUTION: SLIDE PLATE WILL DROP TO THE FLOOR WHEN SLIDE PLATE SECURING BOLTS ARE DISENGAGED. KEEP HANDS AND FEET OUT FROM UNDERNEATH SLIDE PLATE, FAILURE TO DO SO COULD CAUSE SEVERE BODILY INJURY.

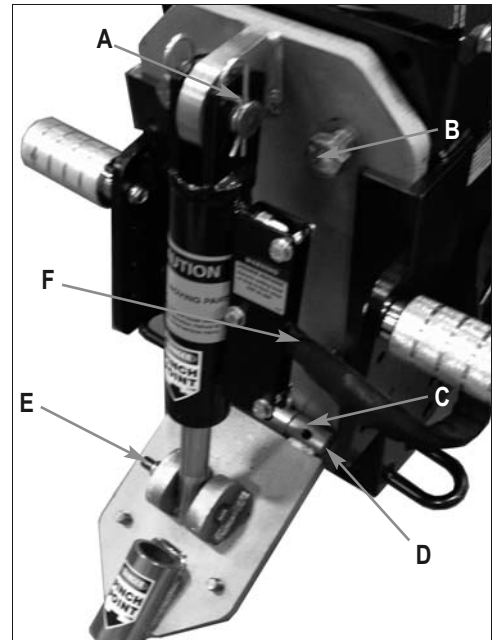

FIG. A

RAISING OR LOWERING THE SLIDE PLATE

This will only work without a cutting head inserted in the machine. Completely loosen slide plate bolts (B). Use cylinder lift lever to raise or lower machine to move slide plate up or down.

LOWER CUTTING HEAD SUPPORT REMOVAL

1. Lower slide plate so cutting head hinge pin (D) is below machine bottom. Retighten.
2. Loosen both cutting head pin set screws (C) at the base of the lower cutting head support (hinge area).
3. Drive cutting head hinge pin (D) out using a punch and hammer.
4. Remove cylinder securing hex head bolt.

DUAL SLIDE PLATE REMOVAL

1. Lower the slide plate to the floor and place a block under the assembly.
2. Remove the front cylinder by taking the 1/2" bolt out of the bottom and removing the pin from the top of the cylinder.
3. Remove the E-clips from the pin at the bottom of the internal cylinder, then remove the pin.
4. Remove the pin from the top of the internal cylinder and then remove the cylinder from the machine.
5. Loosen the bolt from the lower right side of the frame.
6. Remove the lock nut from securing bolts at the top of the slide plate.
7. Remove the socket head screws at the top of the dual slide from both sides of the assembly.
8. Install 3/8-16x5" bolts into the holes the socket head screws were removed from. Once installed the bolts should be used as lifting handles.
9. Lift the frame out of the machine.

Machine Maintenance

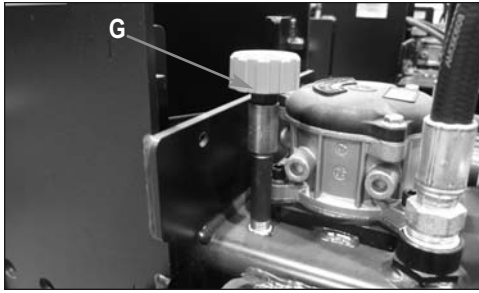

FIG. A

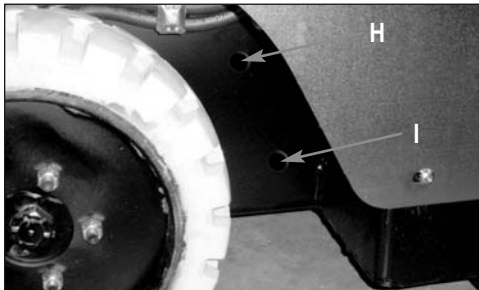

FIG. B

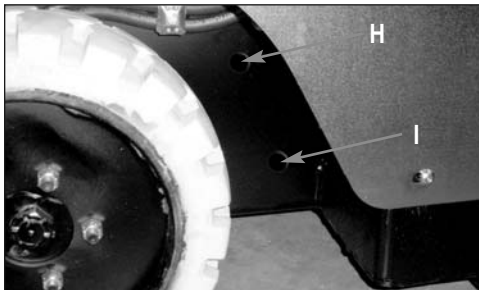

FIG. C

LEAK MAINTENANCE

All fittings on this machine are O-ring style.

1. Disconnect machine from power.
2. If a leak is detected, tighten fitting with the proper wrench size. DO NOT over tighten. Over tightening could damage O-rings.

CHECK OIL LEVEL

1. Remove Breather Dip Stick (G).
2. Check to see that Hydraulic Fluid is visible on Dip Stick.

OR

1. Remove Filler plug (H).
2. Oil should be visual 2" below hole.
3. Reinsert plug.

OIL CHANGE OUT

1. Disconnect machine from power (charger or battery).
2. Drain fluid by removing the drain plug from side of tank (I).
3. Replace drain plug (I).
4. Remove filler plug (H).
5. Add oil into the filler plug hole until visual 2" below hole.

^A

CAUTION: THIS UNIT CONTAINS 7-1/2 GALLONS OF FLUID. MAKE SURE YOU HAVE THE PROPER AMOUNT OF CONTAINERS TO CATCH FLUID.

HOSE CHANGE OUT/REMOVAL

1. Disconnect machine from power.
2. Remove hood.
3. Using proper wrench size, remove hose from fitting.
4. When replacing, make sure O-ring is properly seated on hose fitting.

WHEEL MOTOR CHANGE OUT

1. Disconnect machine from power.
2. Block up machine to remove wheel. See wheel changing on page 30.
3. Remove wheel.
4. Remove oil lines from wheel motor. A small amount of oil will run out of the lines. Drain into a container. Wipe up spills immediately.
5. Remove four 1/2" wheel motor securing nuts.
6. Pull out on wheel motor to remove.

FOOT PEG REMOVAL/REPLACE

1. Insert a socket wrench into foot peg and secure bolt head.
2. Remove nut.
3. Remove bolt and foot peg.
4. Replace foot peg before operating machine. DO NOT use machine without foot pegs.

PUMP CHANGE OUT

1. Remove doghouse to expose pump.
2. Disconnect hydraulic lines.
3. Remove two 5/16" pump securing bolts.
4. Remove pump by pulling pump straight out from pump motor.

VALVE CHANGE OUT

1. Disconnect machine from power (charger or battery).
2. Lift hood and secure in place.
3. Remove hoses from valve body. have a container ready to catch leakage from lines.
4. Take notice of angle of valve fittings.
5. Remove two 1/4" bolts securing valve body.

MOTOR CHANGE OUT

1. Disconnect motor from power.
2. Lift hood and secure in place.
3. Remove pump (see pump change out).
4. Loosen the bracket holding the motor.
5. Remove motor.

HYDRAULIC CYLINDER CHANGE OUT

1. Disconnect machine from power.
2. Disconnect cylinder lines. Have a container ready to catch oil from lines.
3. Remove cylinder securing hexhead bolt from lower cutting head support.
4. Remove clips and pin from cylinder and slide plate.
5. Remove cylinder upper pin.
6. Remove cylinder.

CHANGING HYDRAULIC FLUID FILTER (FIG. A)

Note: Filter should be replaced yearly.

1. Remove old filter by turning counter-clockwise
2. Install new filter by turning clockwise

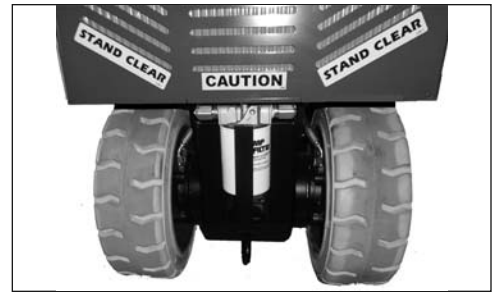

FIG. A



FIG. B

CAUTION: MAKE SURE MACHINE IS SUPPORTED PROPERLY OR SERIOUS INJURY COULD OCCUR.

REAR WHEEL CHANGING (FIG. B)

1. Jack machine up by pushing the cylinder lift forward to lower and adjust the angle of the cutting head to raise machine.
2. Place blocks under Forklift Cups on the side of the machine that wheel is being changed.
3. Let cylinder down resting machine on blocks allowing rear wheel to be lifted off the floor.
4. Remove five 1/2" lug nuts with an extended arm wrench, remove wheel.
5. Replace wheel.
6. Replace five lug nuts and tighten, making sure lug nuts are very tight.
7. Raise cylinder to raise machine off of blocks. Remove blocks and lower machine.

Machine Maintenance



FIG. C



FIG. D

REAR WHEEL CHANGING (CONT.)

8. Repeat to other side if necessary.

CASTER WHEEL MAINTENANCE

1. Keep clean and free of debris, make sure it can move freely.
2. Give a shot of grease in grease zerc on caster every six months to keep moving freely.
3. To remove caster, machine will need to be raised. Push the cylinder lift lever forward to lower and adjust the angle of the cutting head to jack up the machine (Figure C). Block up machine (Figure D). Remove four bolts, pull caster off, clean/replace as needed.
4. Replace caster.
5. Replace and firmly tighten the four bolts.
6. Lower the machine.

Note: A spacer is needed with caster when using an 18 inch wheel.

SEAT REPLACEMENT

1. Remove four (4) hexhead screws on each side of the hood (4 times).
2. Slightly raise seat plate & unplug wire harness.
3. Lift hood off.
4. Remove seat.
5. To replace seat, set seat on top of hood.
6. Replace the four 3/8" x 16" x 3/4" hexhead screws from underneath the hood.
7. Firmly tighten.
8. Reconnect back-up beeper and seat switch wires.
9. Replace hood and screws.

▲

WARNING: DO NOT ALTER A SWITCH OR LEVER. DO NOT DEFEAT A SAFETY DEVICE.

▲

WARNING: THE BACK-UP BEEPER IS ON THE MACHINE FOR SAFETY. IT IS IMPORTANT TO KEEP IT IN GOOD WORKING CONDITION. FAILURE TO DO SO COULD CAUSE BODILY INJURY.

Troubleshooting Guide

Problem	Cause	Solution
Machine will not start.	Seat Safety Switch is engaged.	Make sure that you're sitting on the seat.
	The Emergency Stop (E-Stop) switch is engaged.	Twist the E-Stop switch to expose the green ring.
	The circuit breaker is in the OFF position.	Verify the circuit breaker is in the ON position.
	The 48 volt blue plugs are not connected.	Make sure that connection plugs are fully installed.
	The "start" button did not fully engage.	Firmly press down the green start button.
Machine doesn't run as long as it used to.	Battery is not fully charging.	Verify that you are charging machine with provided seven foot power cord. Verify that the charger is working properly. Charger has a LED light to indicate.
	The 48 volt blue plugs are not connected.	Check that the connection plugs are fully installed.
	Batteries no longer hold a charge.	Call National for procedure to have batteries load tested.
Machine is making rattling noises.	Loose hardware on machine.	Inspect and tighten bolts as needed.
Charger is hot.	Charger is in use.	This is normal.
Fluid is leaking from the machine.	Hose connections/ or fittings have loosened through normal use.	Tighten hydraulic hoses and fittings as needed.
	Pin hole in the hoses.	Replace affected hose.
	Oil and/or oil filter are old.	Replace oil and oil filter yearly on machine.
Tires/Wheel motors make a slight clicking noise.		Normal noise with proper operation.
Machine is jerky or jumpy.	New operator	Additional time is required to become familiar with machine.
	Control levers are being moved to quickly.	Operate control levers with wrist resting on knees for additional support or purchase arm rest.
Coupling leaks at thread or seat.	Missing or damaged O-rings.	Check for missing or damaged O-rings; replace if necessary.
	Damaged threads due to misalignment or improper seat angle.	Correct seat angle. Check for thread damage; replace if necessary.
	Over or under torquing.	Only hand tighten hardware.
Any issues not listed above.		Please contact NFE to speak with a technician.

Parts List and Diagrams

COMPLETE PARTS LIST

PART#	DESCRIPTION	QTY	PART#	DESCRIPTION	QTY		
1	1009	GLASSES, SAFETY	1	56	5200 1G	GASKET, PUMP	1
2	400099	HOSE, SUCTION, 1/2" X 20" W/ FITTINGS	2	57	5200 258	DEFLECTOR, DEBRIS	1
3	400132	BOLT, HEX HEAD, 1/2 13 X 3 1/2	1	58	5200 261	HOSE, WHEEL MOTOR	4
4	400133	MOTOR, WHEEL, HYDRAULIC, 10MM BOLT	2	59	5200 261 1A	CLAMP	2
5	6280 1	OIL, 1 GALLON	8	60	5200 261 1B	BODY ONLY, CLAMP	4
6	400327	HANDGRIP, CUT FOR RIDE ONS	2	61	5200 30	DOGHOUSE BASE, ASSEMBLY	1
7	6280 170A	GRIP, HANDLE BAR	1	62	5200 603	GUIDE, HOSE	1
8	5110 100	WHEEL, TRANSPORT, RIDE ON	1	63	5200QL 13	SPACER, VALVE LEVER	1
9	5110 100D	BRACKET, TRANSPORT WHEEL	1	64	5200QL 1A	PLATE, HYDRAULIC PUMP ADAPTOR	1
10	5110 100W	WHEEL ONLY, FRONT ASSEMBLY	2	65	5200QL 50	PAD, SHOCK, BATTERY	1
11	73207	NUT, NYLOCK 3/8 16	8	66	5213 2	BATTERY, 8 VOLT, 2900	12
12	73208	BOLT, HEX HEAD CAP 3/8 16X1 1/2	8	67	5215	BATTERY CHARGER, INBOARD	1
13	73264	WASHER, FLAT, ZINC USS 3/8	8	68	5700 100	WIRE SET	1
14	5110 111	SEAT, RIDE ON	1	69	5700 102D	NAME PLATE, NAME EMERGENCY STOP	1
15	5110 114 2	FITTING, WHEEL MOTOR	4	70	5700 102	SWITCH, E STOP	1
16	5110 115	SPOOL CONTROL, SINGLE	1	71	5700 103	SWITCH, START	1
17	5110 116	SPOOL CONTROL, DOUBLE	1	72	5700 104	CONTACTOR	1
18	5110 117	WHEEL, HUB	2	73	5700 105	BATTERY FUEL GAUGE	1
19	5110 157	PLUG, DRAIN FILLER	2	74	5700 106	BREAKER, CIRCUIT, 70 AMP	1
20	5110 166	PLATE, SLIDE	1	75	5700 13	TUB, COVER FRONT	1
21	5110 167	SUPPORT, LOWER CUTTING HEAD	1	76	5700 18	BATTERY HOLD DOWN	3
22	5110 170	PIN, CUTTING HEAD	1	77	5700 19	TUB WELDMENT	1
23	5110 180	PEG, FOOT	2	78	5700 20	COVER, BATTERY, UPPER	1
24	5110 207	SWITCH, SEAT	1	79	5700 21	TRAY, BATTERY, UPPER	1
25	5110 218	SWITCH, BACK UP BEEPER	1	80	5700 30	EXTENSION, DOGHOUSE	1
26	5110 234	COUPLER, RELIEF VALVE	1	81	5700 35	SPACER, MOTOR	2
27	5110 234 1	PIPE, RELIEF VALVE	1	82	5700 36	GUARD, HOSE	2
28	5110 237	FILTER SCREEN	2	83	5700 40	COVER, BACKUP SWITCH	1
29	5110 250	CYLINDER NN16	1	84	5700 41	HANDLE, WELDMENT RIGHT	1
30	5110 251	ROD, CYLINDER CONNECT	1	85	5700 42	HANDLE, WELDMENT LEFT	1
31	5110 267	HOSE, CYLINDER	1	86	5700 48	BRACKET, RIGHT VALVE	1
32	5110 268	FITTING, VALVE STRAIGHT	2	87	5700 49	BRACKET, LEFT VALVE	1
33	5110 405	WHEEL, RIM & TIRE 18"	2	88	5700 54	SLEEVE, HAND GRIP	2
34	5110 113 1	WHEEL CENTER, LARGE	1	89	5700 56	SPACER, BATTERY	4
35	5110 18	WHEEL, ONLY 18X6X12 1/8"	1	90	5700 58	BRACKET, FILTER	1
36	5175	KIT, ACCESSORY	1	91	5700 59	BRACKET, BLADE HANDLE	1
37	6260 BD	BLADE, HEAVY DUTY DITCHING 3 X 6	1	92	5700 60	BOLT, BLADE HANDLE	1
38	6277 BU	BLADE, BEVEL UP, 3" X 12"	1	93	5700 62	COVER, BATTERY HOLD DOWN	3
39	6284	BLADE, HEAVY DUTY 3" X 12"	1	94	5700 65	FILTER	1
40	6285	BLADE, HEAVY DUTY 3" X 6"	1	95	5700 66	FILTER HEAD	1
41	6286	BLADE, HEAVY DUTY, 3" X 10"	1	96	5700 67	PLUG, TANK	1
42	7050 10	CUTTING HEAD, 10"	1	97	5700 70	T FITTING	1
43	73422	BOLT, HEX HEAD CAP 1/2 13X3/4	4	98	5700 71	HOSE, RETURN RIGHT	1
44	7050 12	CUTTING HEAD, 12"	1	99	5700 72	HOSE, RETURN LEFT	1
45	73422	BOLT, HEX HEAD CAP 1/2 13X3/4	6	100	5700 76	HOSE, 25"	2
46	7050 6	CUTTING HEAD, 6"	1	101	5700 77	ASSEMBLY, HOSE	1
47	7077 8	SHANK, CUTTING HEAD, TAPERED 3.5" X 8"	1	102	5700 79	HARNES, SEAT	1
48	7079 2	SHANK, ULTRA HD 2" X 6"	1	103	5700 80	HARNES, MAIN	1
49	7079 2B	CARBIDE, .210X2X.875	4	104	5700 81	HOSE, SUCTION LINE	1
50	7079 6	SHANK, ULTRA HD 6" X 6"	1	105	5700 85	COVER, TERMINAL STRIP	1
51	5200 116	BEEPER, BACK UP	1	106	5700 88	METER, HOUR	1
52	5200 118 8	CONNECTOR, BLUE 48V BATTERY	2	107	5700 89	HANDLE, CHEST	2
53	5200 162A	FRAME, RIDE ON	1	108	5700 90	RELAY, SOCKET	1
54	5200 18	CLAMP, FRONT MOTOR	2	109	5700 91	RELAY	1
55	5200 194	CASTER, DOUBLE GRAY	1	110	5700 93	GASKET	1

****PARTS ARE SOLD INDIVIDUALLY. PLEASE NOTE THE QUANTITY NEEDED WHEN ORDERING****

Parts List and Diagrams

COMPLETE PARTS LIST

PART#	DESCRIPTION	QTY	PART#	DESCRIPTION	QTY
111 6280 118	FITTING, SUCTION HOSE TO PUMP	2	166 73259	BOLT, FLANGE, SERRATED, SAE 3/8 16X3/4	11
112 6280 162G	MAGNET, TANK	2	167 73263	WASHER, FLAT SEA ZINC 3/8	2
113 70354	HOSE, 3/4", RETURN LINE TO TANK	1	168 73264	WASHER, FLAT, ZINC USS 3/8	2
114 70355	HOSE, 3/4", RETURN LINE TO FILTER	1	169 73270	PIN, 3/8 X 3	1
115 70549	WRENCH, SLIDE PLATE 1 1/8"	1	170 73303	WASHER, SPLIT LOCK 5/16	4
116 5110 402 1A	WRENCH ONLY WO/SOCKET	1	171 73311	SCREW, SH CAP, GRADE 5 5/16 18X1	8
117 70549 1	SOCKET, 1 1/8", 6PT 1/2" DR	1	172 73315	BOLT, FLAT HEAD SOCKET 5/16 18X1	6
118 70549 2	SOCKET, 3/4", 6PT 1/2" DRIV	1	173 73318	BOLT, WIZLOCK FLANGE 5/16 18X5/8	2
119 70602	TUBE, INSTRUCTION MANUAL	1	174 73320	BOLT, SOCKET HEAD CAP 5/16 18X2	1
120 70603	CAP, INSTRUCTION TUBE	1	175 73321	BOLT, SOCKET HEAD CAP 5/16 18X3	1
121 70613	BRACKET, OIL FILTER	1	176 73322	NUT, NYLOCK 5/16 18	7
122 70651	PLUG, VALVE BODY	4	177 73334	BOLT, HEX HEAD CAP 5/16 18X1 1/2	3
123 70652	FITTING	2	178 73345	BOLT, BUTTON HEAD CAP 5/16 18X1	4
124 70653	FITTING, 90 DEGREE	4	179 73351	WASHER, FLAT SAE ZINC 5/16	3
125 70654	FITTING, REDUCER	1	180 73402	NUT, NYLOCK 1/2 13	9
126 70655	PIPE, MALE, 10" X 3/4"	1	181 73403	WASHER, SPLIT LOCK 1/2	7
127 70905 D4	PUMP, DOUBLE, MARZOCCHI	1	182 73414	BOLT, HEX HEAD 1/2 13X7	1
128 71703	PROTECTOR, BATTERY TERMINAL, RED	17	183 73424	WASHER, FLAT, ZINC SAE 1/2	7
129 71704	PROTECTOR, BATTERY TERMINAL, BLK	13	184 73427	BOLT, HEX HEAD CAP 1/2 13X1 1/2	7
130 72385	MOTOR, 4 HP, XP2135	1	185 73430	NUT, NYLOCK 1/2 20	10
131 72801	FITTING, 90 DEGREE, 1/4"	2	186 73531	WASHER, FLAT SAE ZINC 5/8	1
132 72816	FITTING, ELBOW, 90 DEGREE, 3/8"	6	187 73536	PIN, HITCH CLIP 5/8"	2
133 72823	CLAMP, METAL CABLE 3/8"	4	188 73605	BOLT, HEX HEAD, GRADE 8, 3/4 10X1 1/2	4
134 72840	TIE, CABLE, BLACK 4	3	189 74406	SCREW, PHILLIPS PAN HEAD 10 32X3/8	2
135 72844	TIE, CABLE, MOUNTING BASE, FOURWAY	3	190 74425	NUT, KEPS LOCK 10 32	12
136 73002	WASHER, SPLIT LOCK 1/4	4	191 74431	SCREW, PHILLIPS FH, ZINC H10 32X1/2	10
137 73005	SCREW, HEX HEAD CAP 1/4 20X1/2	2	192 74501	WASHER, #6 FLAT SAE	4
138 73008	NUT, NYLOCK 1/4 20	4	193 74517	SCREW, PHILLIPS PAN HEAD MAC 6 32X1	2
139 73013	BOLT, HEX HEAD CAP 1/4 20X1 1/4	2	194 74518	NUT, HEX W/TOOTH WASHER 6 32	2
140 73020	BOLT, WIZLOCK 1/4 20X5/8	2	195 74834	FITTING, 90 DEG	2
141 73020	BOLT, WIZLOCK 1/4 20X5/8	2	196 74854	WEIGHT, POCKET, CAST, RIDE ON	5
142 73021	BOLT, HEX HEAD CAP 1/4 20X2 1/4	1	197 80058	BREATHER, W/6" DIP STICK	1
143 73023	BOLT, HEX HEAD CAP 1/4 20X2	4	198 L08 1	LABEL, STAND CLEAR	2
144 73027	BOLT, FLANGE 1/4 20X3/4	3	199 L106	LABEL, PINCH POINT	2
145 73092	WASHER, FLAT USS ZINC 1/4	2	200 L118	LABEL, OPERATOR MUST BE SEATED	2
146 73063	BOLT, HEX HEAD CAP 1/4 20X1 3/4	2	201 L127	LABEL, CAUTION OPERATING	1
147 73091	WASHER, FLAT, ZINC, SAE 1/4	2	202 L137	LABEL, DISARM MACHINE	3
148 73091	WASHER, FLAT, ZINC, SAE 1/4	6	203 L141	LABEL, FLAG MADE IN US	2
149 73131	PIN, KOTTER 3/32X1 3/4	2	204 L155	LABEL, GENERAL WARNING	1
150 73202	WASHER, INTERNAL LOCK 3/8	2	205 L176	LABEL, NATIONAL	2
151 73204	WASHER, SPLIT LOCK 3/8	4	206 L176	LABEL, NATIONAL	1
152 73205	BOLT, HEX HEAD CAP 3/8 16X3/4	6	207 L223	LABEL, PATENT NUMBER	1
153 73207	NUT, NYLOCK 3/8 16	2	208 L305	LABEL, DO NOT GET CHARGER WET	1
154 73207	NUT, NYLOCK 3/8 16	6	209 L308	LABEL, 5700	2
155 73210	WASHER, INTERNAL/EXTERNAL LOCK 3/8	1	210 L309	LABEL, "A"	6
156 73211	NUT, FLANGE ZINC 3/8 16	1	211 L310	LABEL, "B"	6
157 73212	BOLT, BUTTON HEAD CAP 3/8 16X1/2	2	212 L311 2	LABEL, BATTERY	12
158 73224	BOLT, FLANGE 3/8 16X1/2	4	213 L33B	LABEL, CAUTION MOVING PART	1
159 73227	SCREW, SET 3/8 24X1	2	214 L33C	LABEL, INSTRUCTION MANUAL	1
160 73233	BOLT, HEX HEAD CAP 3/8 16X3 1/2	1	215 L33D	LABEL, AUTHORIZED PERSONEL ONLY	1
161 73235	NUT, HEX JAMB 3/8 24	2	216 L37	LABEL, CAUTION SHRP BLDS	4
162 73238	BOLT, FLANGE 3/8 16X1 1/2	3	217 L38	LABEL, DISCONNECT POWER	1
163 73242	SCREW, BH CAP WITH FLANGE 3/8 16 X 1	2	218 L66	LABEL, LARGE CAUTION	1
164 73248	SCREW, SET 3/8 16X1/4	2	219 L95F	LABEL, FLUID LEAK	2
165 73254	BOLT, FH, SOCKET CAP, 3/8 16 X 1 1/4	4	220 L98	LABEL, BLADE LIFT	1

****PARTS ARE SOLD INDIVIDUALLY. PLEASE NOTE THE QUANTITY NEEDED WHEN ORDERING****

Parts List and Diagrams

EXTERNAL PARTS

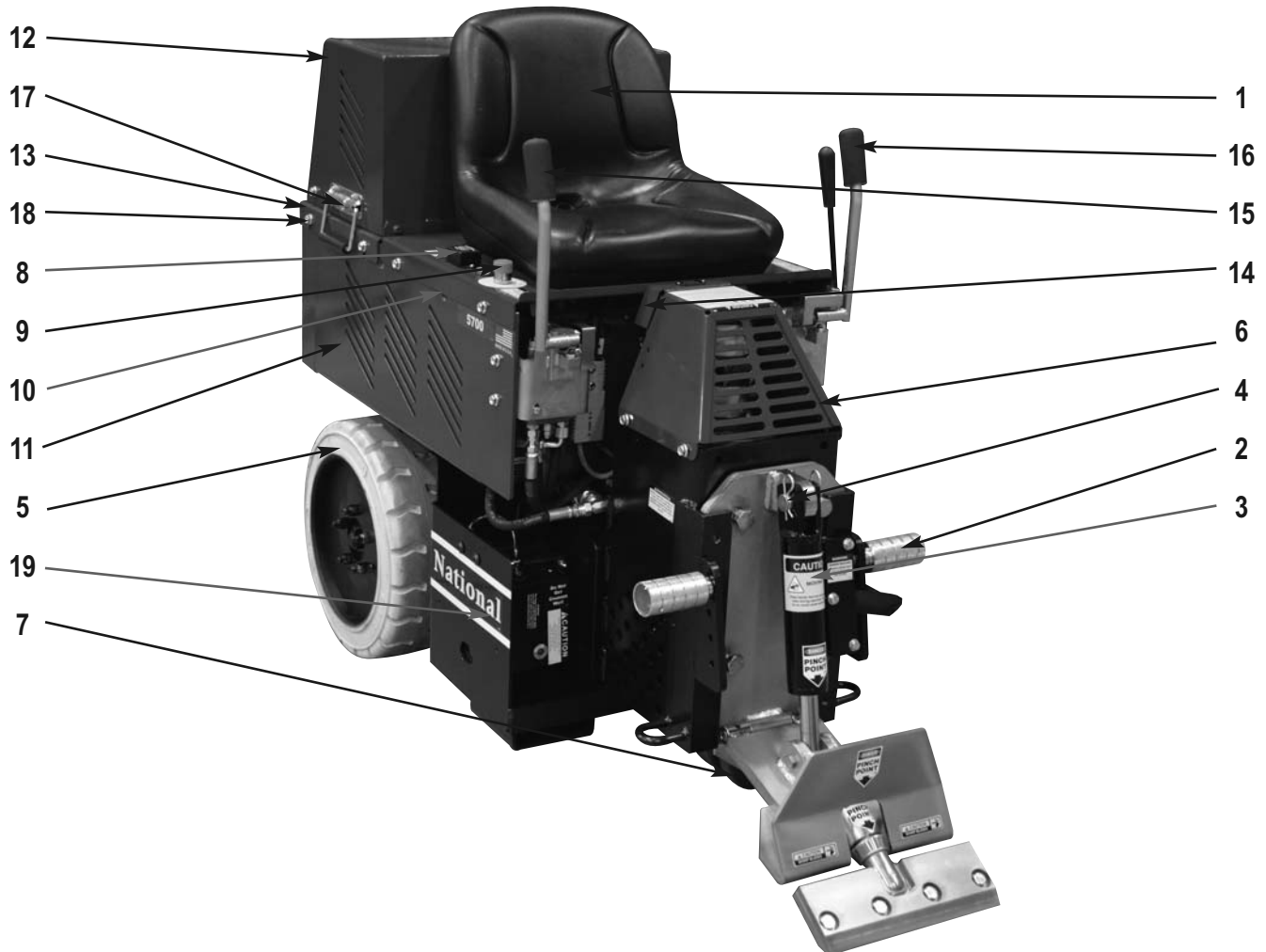

PART#	DESCRIPTION	QTY	PART#	DESCRIPTION	QTY
1	5110 111 SEAT, RIDE ON	1	12	5700 20 COVER, BATTERY, UPPER	1
2	5110 180 PEG, FOOT	2	13	5700 21 TRAY, BATTERY, UPPER	1
3	5110 250 CYLINDER NN16	1	14	5700 30 EXTENSION, DOGHOUSE	1
4	5110 251 ROD, CYLINDER CONNECT	1	15	5700 41 HANDLE, WELDMENT RIGHT	1
5	5110 405 WHEEL, RIM & TIRE 18"	2	16	5700 42 HANDLE, WELDMENT LEFT	1
6	5200 30 DOGHOUSE BASE, ASSEMBLY	1	17	5700 89 HANDLE, CHEST	2
7	5200 194 CASTER, DOUBLE GRAY	1	18	73212 BOLT, BUTTON HEAD CAP 3/8 16X1/2	2
8	5700 103 SWITCH, START	1	19	5215 BATTERY CHARGER, INBOARD	1
9	5700 102 SWITCH, E STOP	1	20	72705 50 AMP 48 VOLT CHARGER CONNECTOR	1
10	5700 13 TUB, COVER FRONT	1			
11	5700 19 TUB WELDMENT	1			

****PARTS ARE SOLD INDIVIDUALLY. PLEASE NOTE THE QUANTITY NEEDED WHEN ORDERING****

Parts List and Diagrams

CYLINDER ASSEMBLY

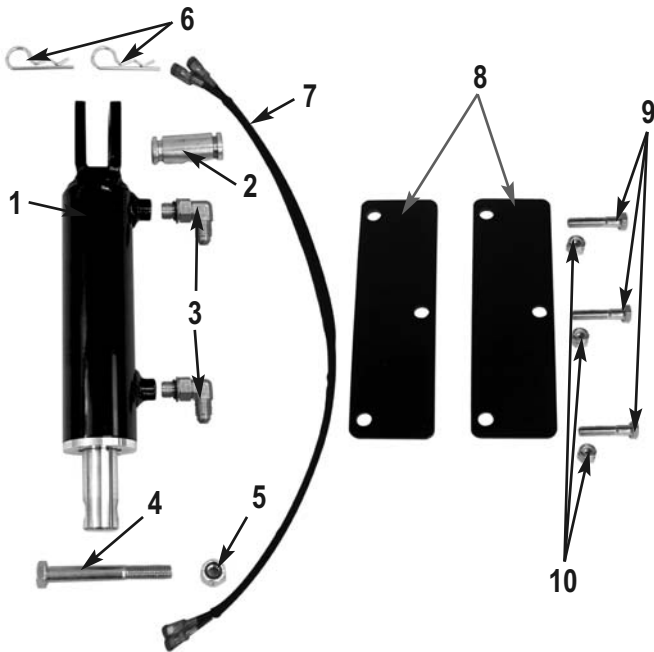

PART#	DESCRIPTION	QTY
1	5110 250 CYLINDER NN16	1
2	5110 251 ROD, CYLINDER CONNECT	1
3	72801 FITTING, 90 DEGREE, 1/4"	2
4	400132 BOLT, HEX HEAD, 1/2 13 X 3 1/2	1
5	73402 NUT, NYLOCK 1/2 13	1
6	73536 PIN, HITCH CLIP 5/8"	2
7	5110 267 HOSE, CYLINDER	1
8	5700 36 GUARD, HOSE	2
9	73334 BOLT, HEX HEAD CAP 5/16 18X1 1/2	3
10	73322 NUT, NYLOCK 5/16 18	2

SLIDE PLATE ASSEMBLY

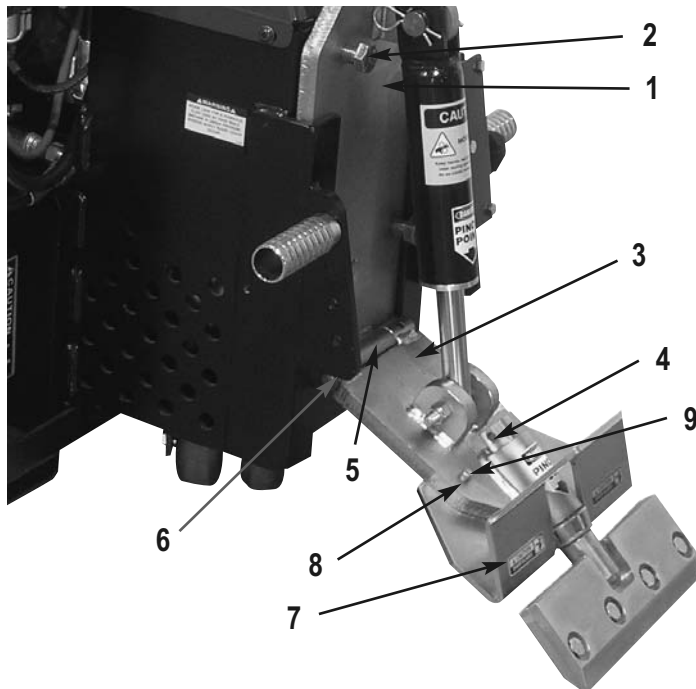

PART#	DESCRIPTION	QTY
1	5110 166 PLATE, SLIDE	1
2	73605 BOLT, HEX HEAD, GRADE 8, 3/4 10X1 1/2	4
3	5110 167 SUPPORT, LOWER CUTTING HEAD	1
4	73270 PIN, 3/8 X 3	1
5	5110 170 PIN, CUTTING HEAD	1
6	73248 SCREW, SET 3/8 16X1/4	2
7	5200 258 DEFLECTOR, DEBRIS	1
8	73403 WASHER, SPLIT LOCK 1/2	2
9	73427 BOLT, HEX HEAD CAP 1/2 13X1 1/2	2

****PARTS ARE SOLD INDIVIDUALLY. PLEASE NOTE THE QUANTITY NEEDED WHEN ORDERING****

Parts List and Diagrams

CASTER WHEEL ASSEMBLY

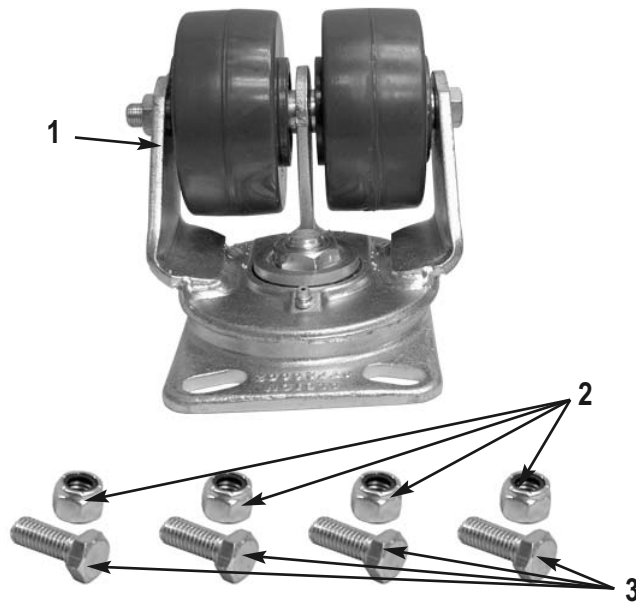

	PART#	DESCRIPTION	QTY
1	5200 194	CASTER, DOUBLE GRAY	1
2	73402	NUT, NYLOCK 1/2 13	8
3	73427	BOLT, HEX HEAD CAP 1/2 13X1 1/2	4

REAR WHEEL ASSEMBLY

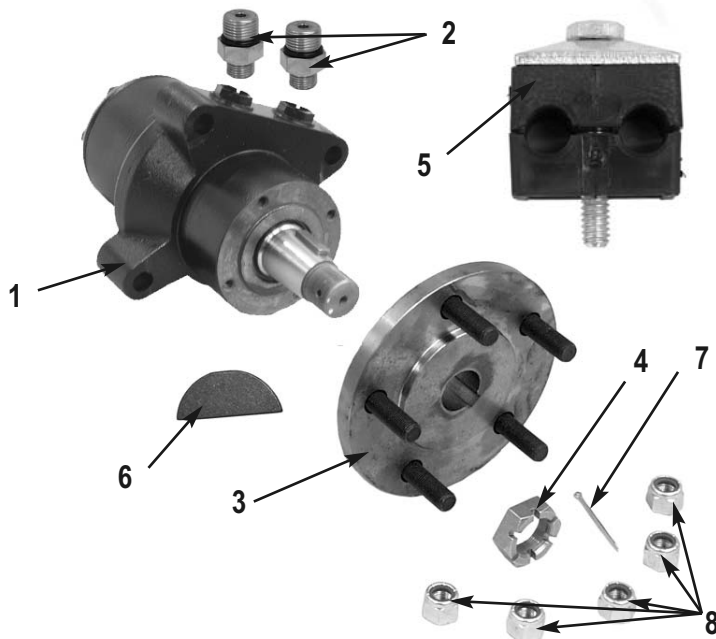

	PART#	DESCRIPTION	QTY
1	400133	MOTOR, WHEEL, HYDRAULIC, 10MM BOLT	2
2	5110 114 2	FITTING, WHEEL MOTOR	4
3	5110 117	WHEEL, HUB	2
4	5110 117 2	NUT, HUB	2
5	5200 261 1A	CLAMP	2
6	73047	KEY, WOODRUFF 1/4 X 1	1
7	73131	PIN, KOTTER 3/32X1 3/4	2
8	73430	NUT, NYLOCK 1/2 20	10
9	5110 405	WHEEL, RIM & TIRE 18" (NOT SHOWN)	2

****PARTS ARE SOLD INDIVIDUALLY. PLEASE NOTE THE QUANTITY NEEDED WHEN ORDERING****

Parts List and Diagrams

ELECTRICAL BOX ASSEMBLY

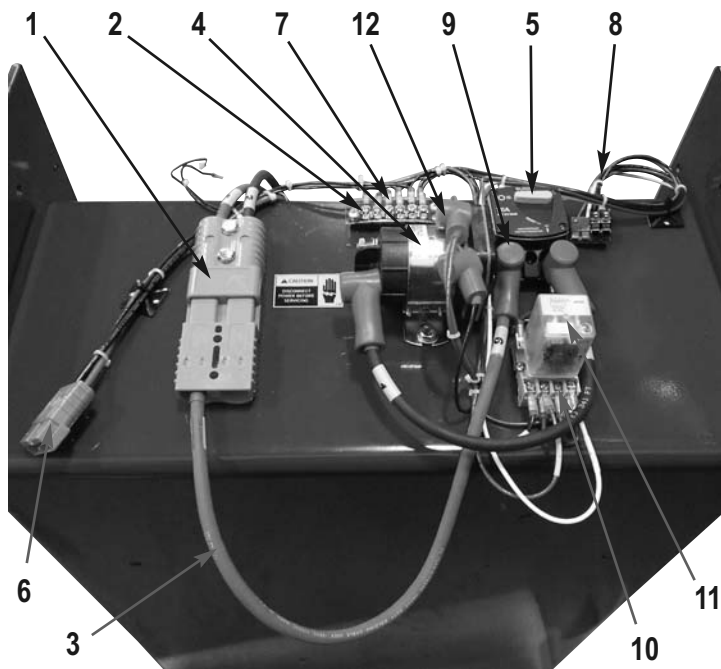

PART#	DESCRIPTION	QTY
1	5200 118 8 CONNECTOR, BLUE 48V BATTERY	2
2	5200 127 STRIP, ELECTRICAL	1
3	5700 100 WIRE SET (PARTIAL SHOWN)	1
4	5700 104 CONTACTOR	1
5	5700 106 BREAKER, CIRCUIT, 70 AMP	1
6	72705 PLUG, 48V	1
7	5700 85 COVER, TERMINAL STRIP	1
8	5700 80 HARNESS, MAIN	1
9	71703 PROTECTOR, BATTERY TERMINAL, RED	3
10	5700 90 RELAY, SOCKET	1
11	5700 91 RELAY	1
12	72834 PROTECTOR, SMALL	2
13	5200 118 9 CONNECTOR, BLUE 48V BATTERY (NOT SHOWN)	2

BATTERY

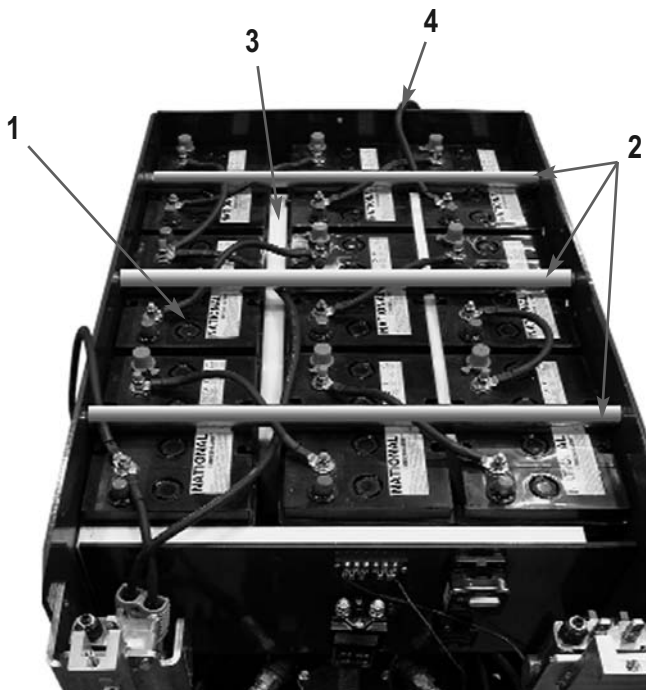

PART#	DESCRIPTION	QTY
1	5213 2 BATTERY, 8 VOLT, 2900	12
2	5700 18 BATTERY HOLD DOWN	3
3	5700 56 SPACER, BATTERY	4
4	5700 100 WIRE SET (PARTIAL SHOWN)	1

****PARTS ARE SOLD INDIVIDUALLY. PLEASE NOTE THE QUANTITY NEEDED WHEN ORDERING****

Parts List and Diagrams

BACK UP BEEPER ASSEMBLY



	PART#	DESCRIPTION	QTY
1	5200 116	BEEPER, BACK UP	1

HANDLE SWITCH (FOR BEEPER)

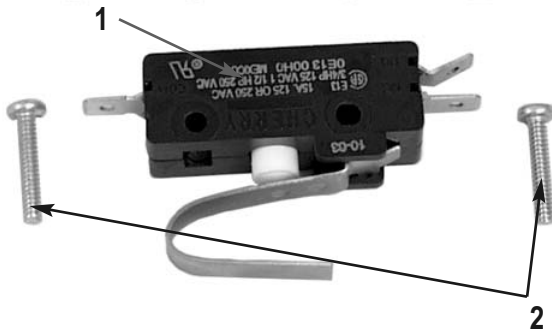

	PART#	DESCRIPTION	QTY
1	5110 218	SWITCH, BACK UP BEEPER	1
2	574517	SCREW, PHILLIPS PAN HEAD MAC 6 32X1	2
3	700 40	COVER, BACKUP SWITCH (NOT SHOWN)	1

INSTRUCTION TUBE ASSEMBLY

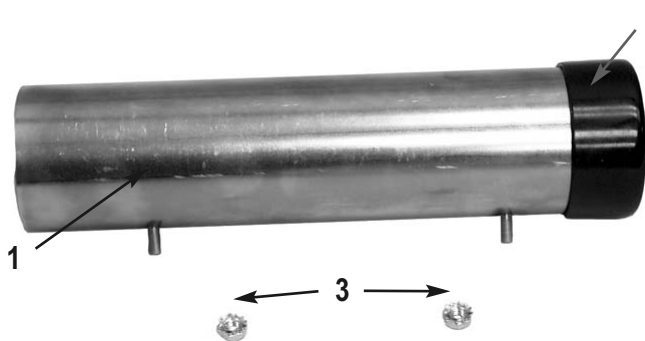

	PART#	DESCRIPTION	QTY
1	70602	TUBE, INSTRUCTION MANUAL	1
2	70603	CAP, INSTRUCTION TUBE	1
3	74425	NUT, KEPS LOCK 10 32	2

FOOT PEG ASSEMBLY

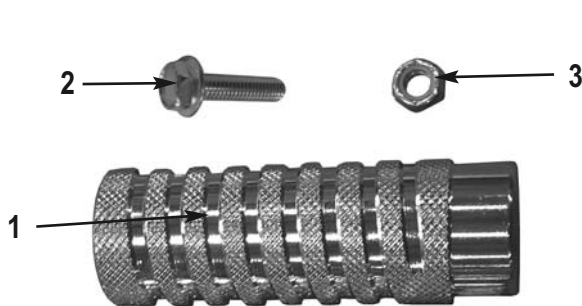

	PART#	DESCRIPTION	QTY
1	5110 180	PEG, FOOT	2
2	73238	BOLT, FLANGE 3/8 16X1 1/2	2
3	73207	NUT, NYLOCK 3/8 16	2

****PARTS ARE SOLD INDIVIDUALLY. PLEASE NOTE THE QUANTITY NEEDED WHEN ORDERING****

Parts List and Diagrams

SPOOL AND HOSE PARTS

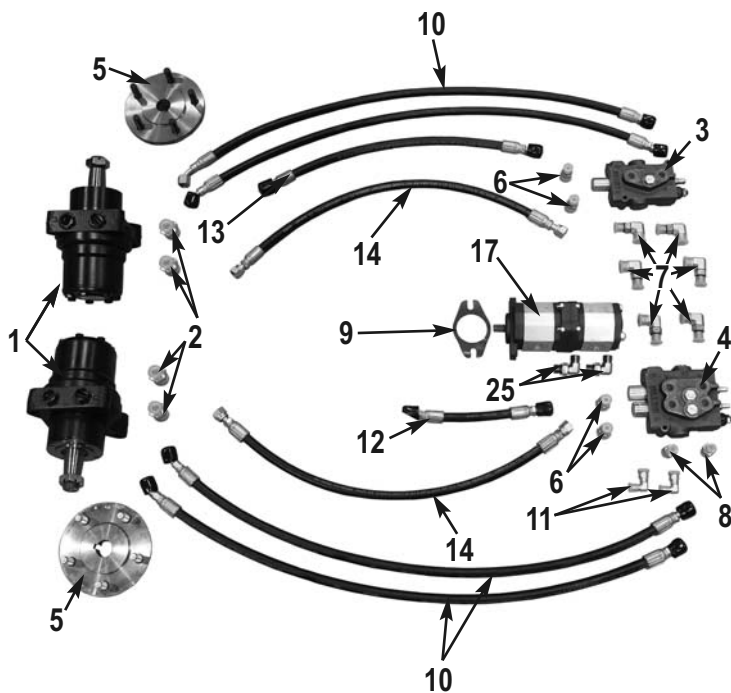

PART#	DESCRIPTION	QTY
1	400133 MOTOR, WHEEL, HYDRAULIC, 10MM BOLT	2
2	5110 114 2 FITTING, WHEEL MOTOR	4
3	5110 115 SPOOL CONTROL, SINGLE	1
4	5110 116 SPOOL CONTROL, DOUBLE	1
5	5110 117 WHEEL, HUB	2
6	70651 PLUG, VALVE BODY	4
7	72816 FITTING, ELBOW, 90 DEGREE, 3/8"	6
8	5110 268 FITTING, VALVE STRAIGHT	2
9	5200 1G GASKET, PUMP	1
10	5200 261 HOSE, WHEEL MOTOR	4
11	74834 FITTING, 90 DEG	2
12	5700 71 HOSE, RETURN RIGHT	1
13	5700 72 HOSE, RETURN LEFT	1
14	5700 76 HOSE, 25"	2
15	5700 77 ASSEMBLY, HOSE	1
16	5700 81 HOSE, SUCTION LINE	1
17	70905 D4 PUMP, DOUBLE, MARZOCCHI	1
18	5700 65 FILTER	1
19	5700 66 FILTER HEAD	1
20	70653 FITTING, 90 DEGREE	2
21	70354 HOSE, 3/4", RETURN LINE TO TANK	1
22	70355 HOSE, 3/4", RETURN LINE TO FILTER	1
23	5110 250 CYLINDER NN16	1
24	5110 267 HOSE, CYLINDER	1
25	6280 118 FITTING, SUCTION HOSE TO PUMP	2
26	5110 237 FILTER SCREEN	2
27	5110 234 COUPLER, RELIEF VALVE	1
28	5110 234 1 PIPE, RELIEF VALVE	1
29	5110 157 PLUG, DRAIN FILLER	2
30	5700 64 FITTING, FILTER	1
31	5700 67 PLUG, TANK	1
32	70654 FITTING, REDUCER	1
33	5700 70 T FITTING	1

FILTER AND TANK PARTS

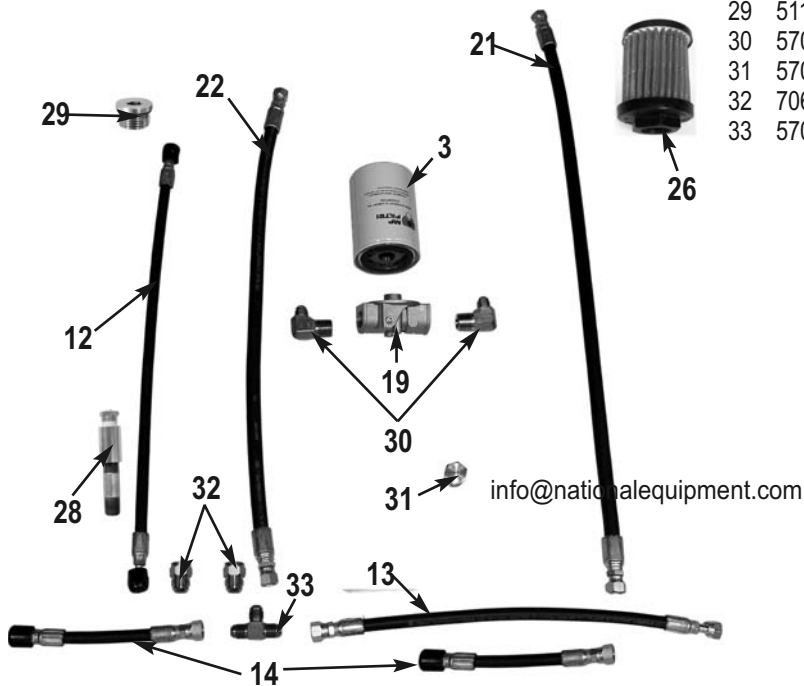

****PARTS ARE SOLD INDIVIDUALLY. PLEASE NOTE THE QUANTITY NEEDED WHEN ORDERING****

Parts List and Diagrams

HYDRAULIC FLOW DIAGRAM

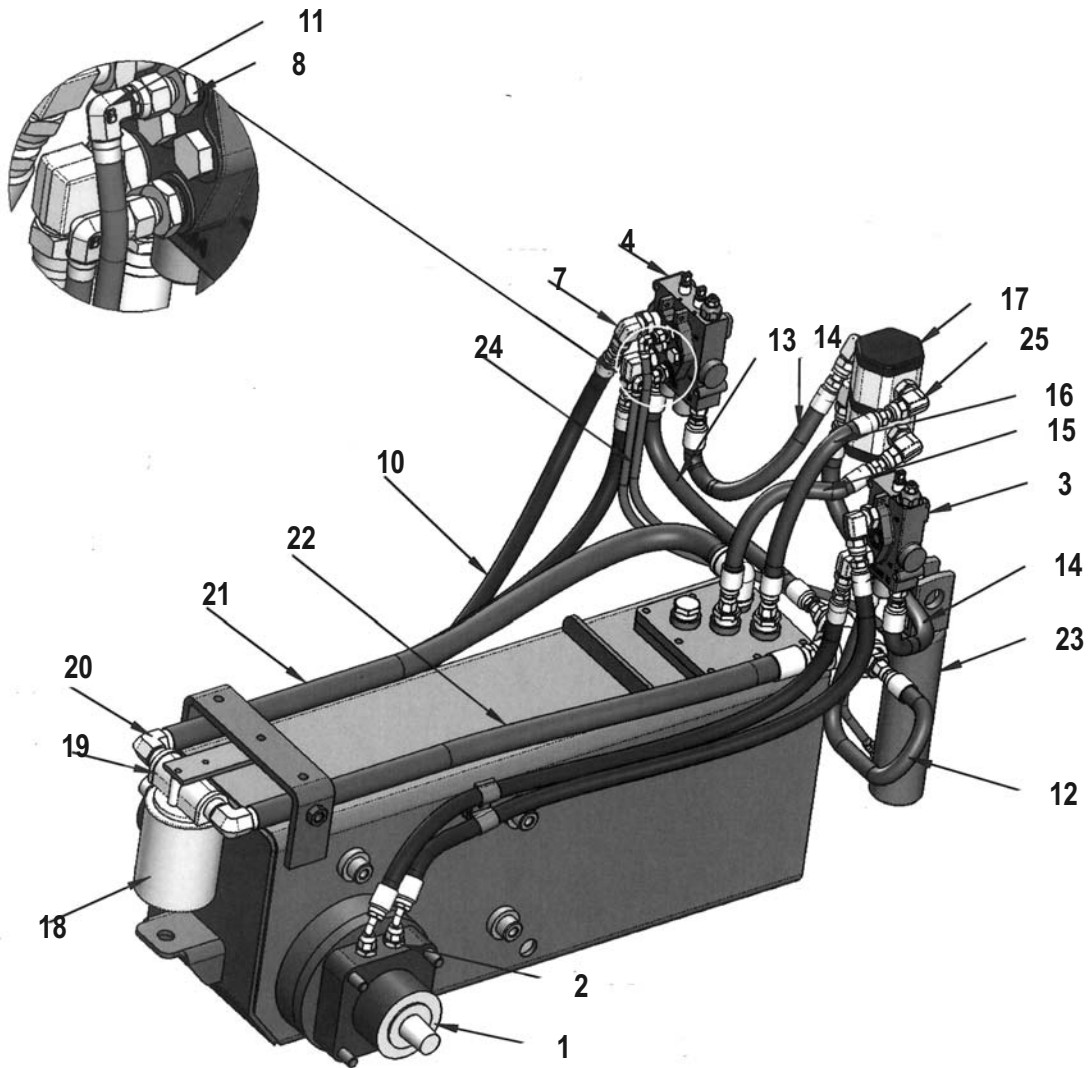

THE ASSOCIATED NUMBERS FOR THESE CALLOUTS ARE ON PAGE 40

****PARTS ARE SOLD INDIVIDUALLY. PLEASE NOTE THE QUANTITY NEEDED WHEN ORDERING****

Parts List and Diagrams

MOTOR

PART#	DESCRIPTION	QTY
1	72385 MOTOR, 4 HP, XP2135	1
2	5200QL 1A PLATE, HYDRAULIC PUMP ADAPTOR	1
3	73242 SCREW, BH CAP WITH FLANGE 3/8 16 X 1	4
4	5200 18 CLAMP, FRONT MOTOR	2
5	73201 SCREW, HEX HEAD CAP 3/8 16X1	2
6	73204 WASHER, SPLIT LOCK 3/8	2
7	5700 35 SPACER, MOTOR	2

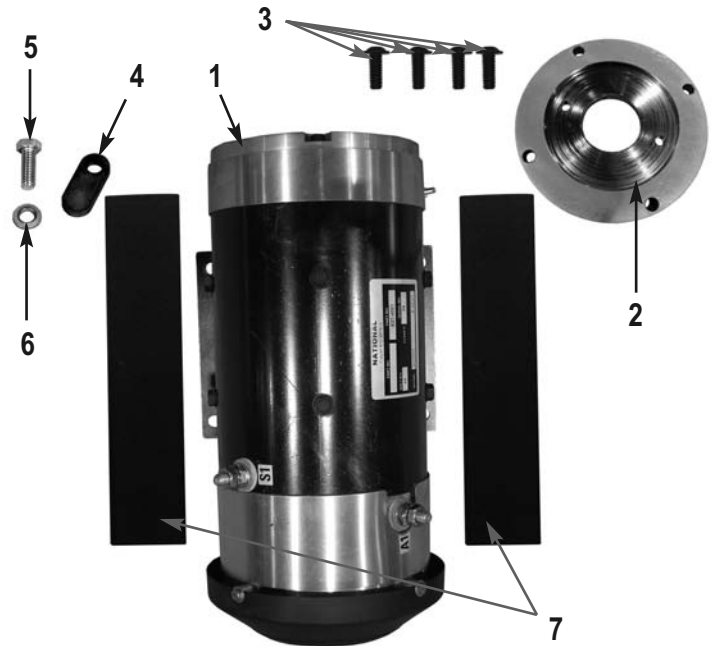

GEAR PUMP ASSEMBLY

PART#	DESCRIPTION	QTY
1	70905 D4 PUMP, DOUBLE, MARZOCCHI	1
2	5200 1G GASKET, PUMP	1
3	72816 FITTING, ELBOW, 90 DEGREE, 3/8"	2
4	6280 118 FITTING, SUCTION HOSE TO PUMP	2
5	73263 WASHER, FLAT SEA ZINC 3/8	2
6	73204 WASHER, SPLIT LOCK 3/8	2
7	73205 BOLT, HEX HEAD CAP 3/8 16X3/4	2

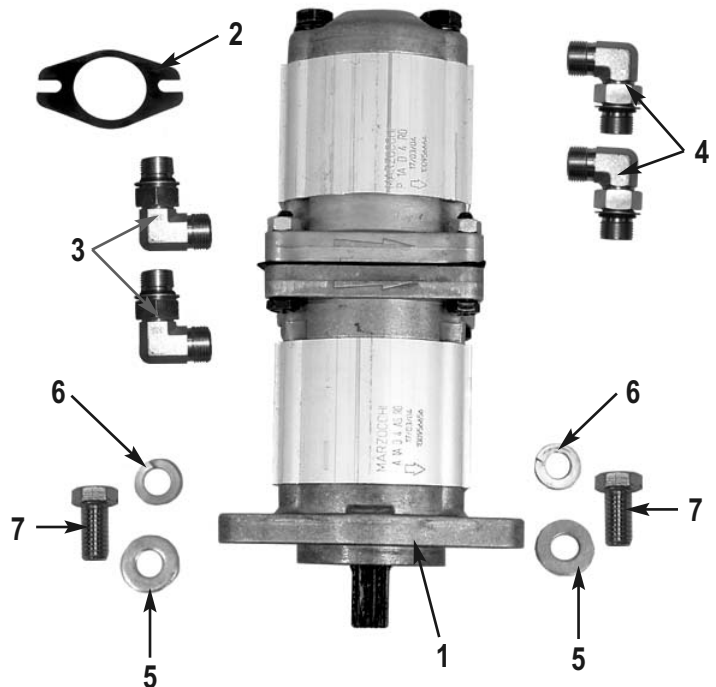

****PARTS ARE SOLD INDIVIDUALLY. PLEASE NOTE THE QUANTITY NEEDED WHEN ORDERING****

Parts List and Diagrams

LABELS

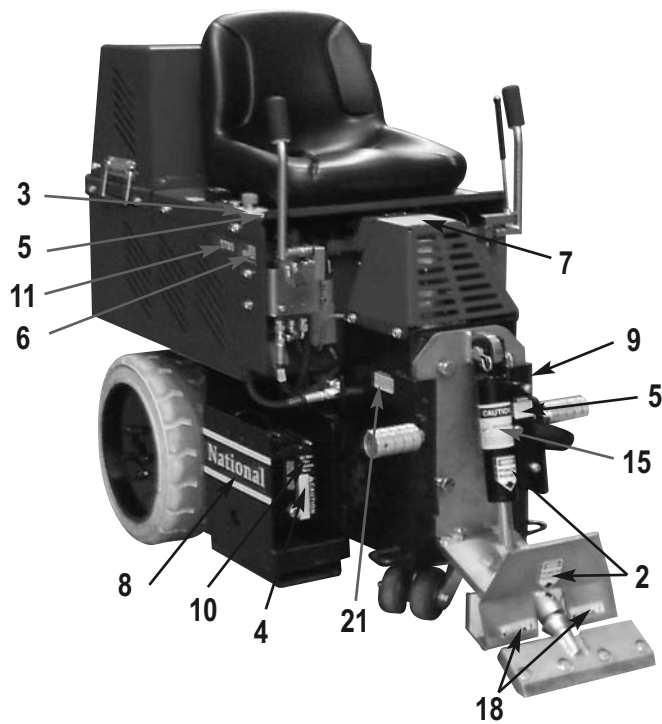

	PART#	DESCRIPTION	QTY
1	L08 1	LABEL, STAND CLEAR	2
2	L106	LABEL, PINCH POINT	2
3	L118	LABEL, OPERATOR MUST BE SEATED	2
4	L127	LABEL, CAUTION OPERATING	1
5	L137	LABEL, DISARM MACHINE	3
6	L141	LABEL, FLAG MADE IN US	2
7	L155	LABEL, GENERAL WARNING	1
8	L176	LABEL, NATIONAL	3
9	L223	LABEL, PATENT NUMBER (NOT VISIBLE)	1
10	L305	LABEL, DO NOT GET CHARGER WET	1
11	L308	LABEL, 5700	2
12	L309	LABEL, "A" (ON BATTERY, NOT SHOWN)	6
13	L310	LABEL, "B" (ON BATTERY, NOT SHOWN)	6
14	L311 2	LABEL, BATTERY (NOT SHOWN)	12
15	L33B	LABEL, CAUTION MOVING PART	1
16	L33C	LABEL, INSTRUCTION MANUAL	1
17	L33D	LABEL, AUTHORIZED PERSONEL ONLY	1
18	L37	LABEL, CAUTION SHARP BLADES	4
19	L38	LABEL, DISCONNECT POWER	1
20	L66	LABEL, LARGE CAUTION	1
21	L95F	LABEL, FLUID LEAK	2
22	L98	LABEL, BLADE LIFT	1

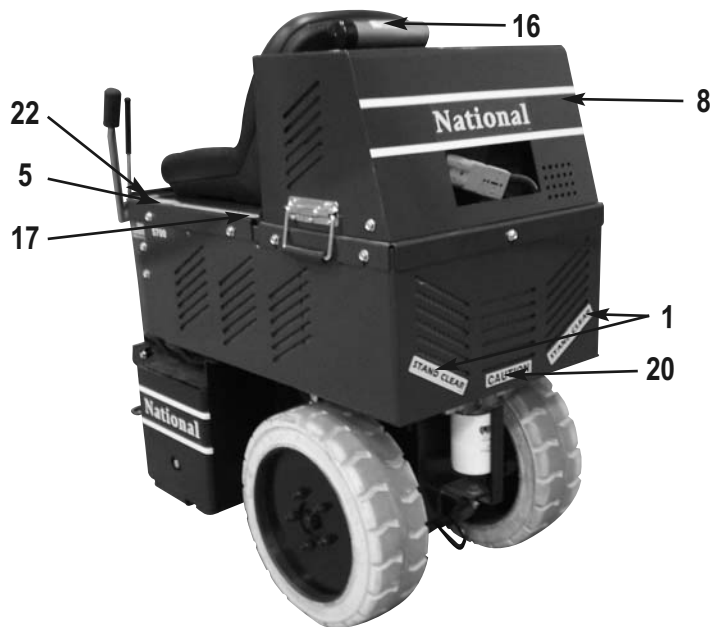

****PARTS ARE SOLD INDIVIDUALLY. PLEASE NOTE THE QUANTITY NEEDED WHEN ORDERING****

Parts List and Diagrams

WEIGHTS

	PART#	DESCRIPTION	QTY
1	74854	WEIGHT, 36 LB. REMOVABLE	5
2	73424	WASHER, FLAT, ZINC SAE 1/2	7
3	73403	WASHER, SPLIT LOCK 1/2	7
4	73414	BOLT, HEX HEAD 1/2 13X7	1
5	73406	SCREW, CAP HEXHEAD 1/2-13 X 1-1/4 (NS)	?



WRENCH

	PART#	DESCRIPTION	QTY
1	70549	WRENCH, SLIDE PLATE 1 1/8"	1



****PARTS ARE SOLD INDIVIDUALLY. PLEASE NOTE THE QUANTITY NEEDED WHEN ORDERING****

Parts List and Diagrams

5700 BATTERY WIRING

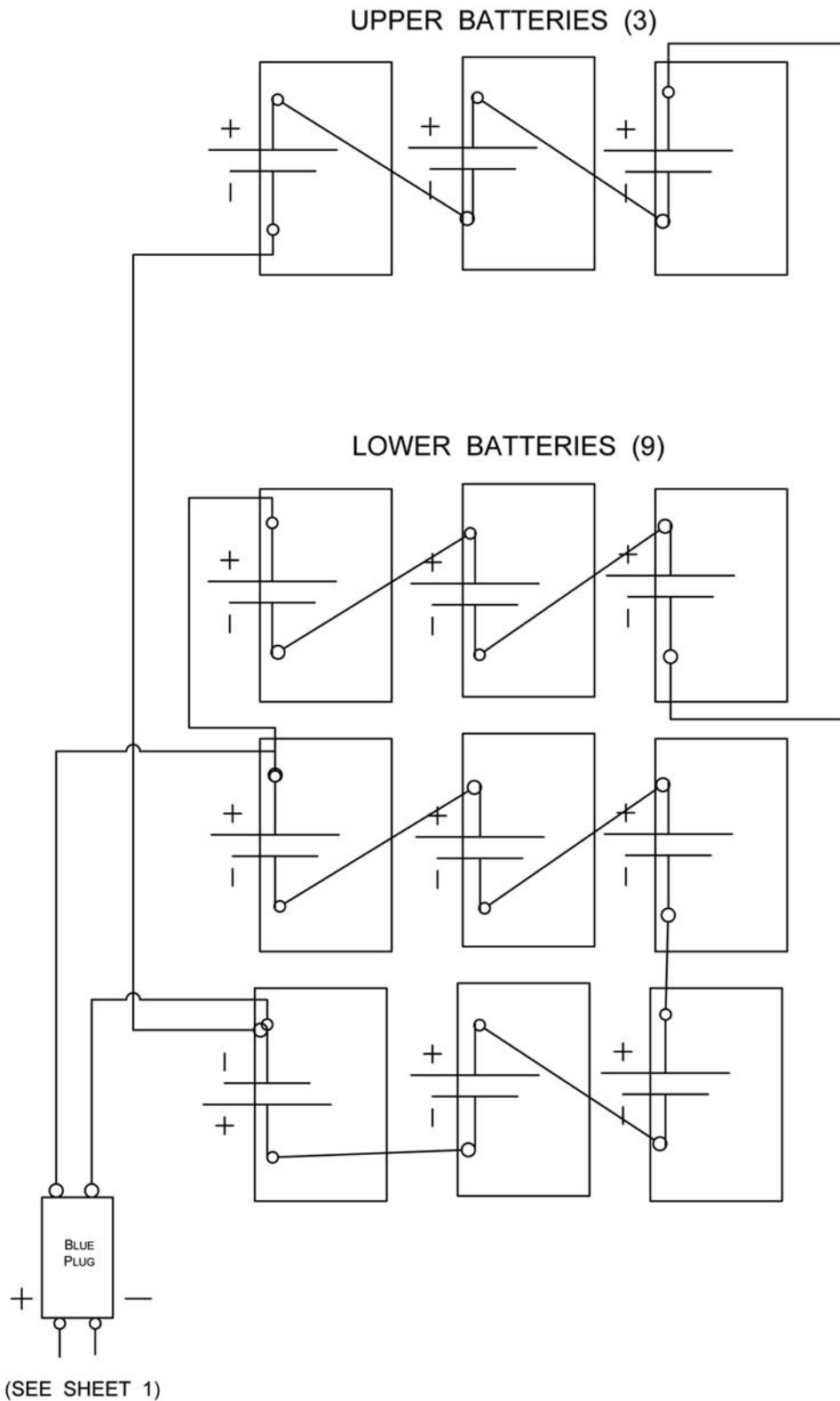

5700 SEAT WIRING

(SEE SHEET 1)

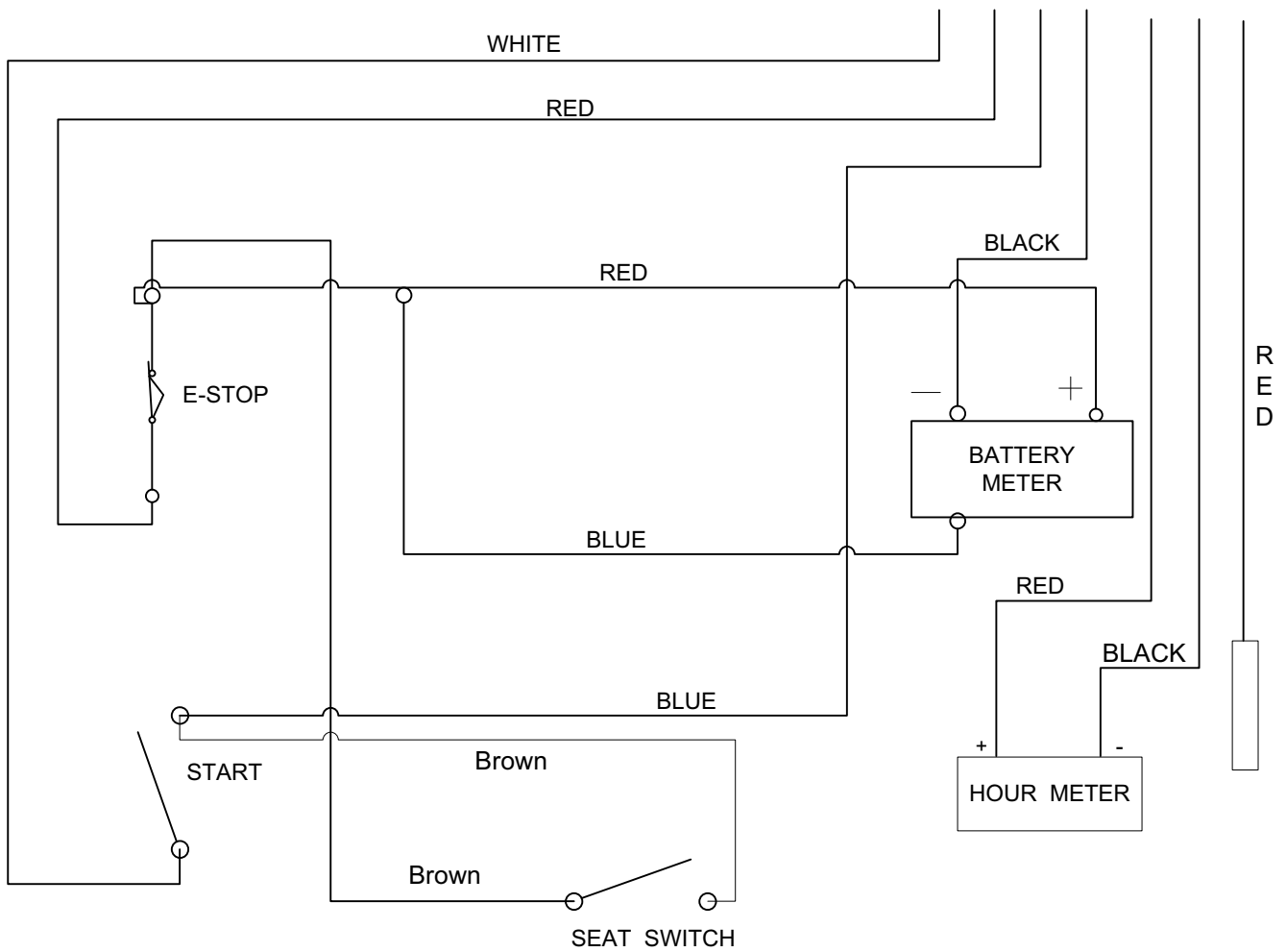

Parts List and Diagrams

5700 MACHINE WIRING

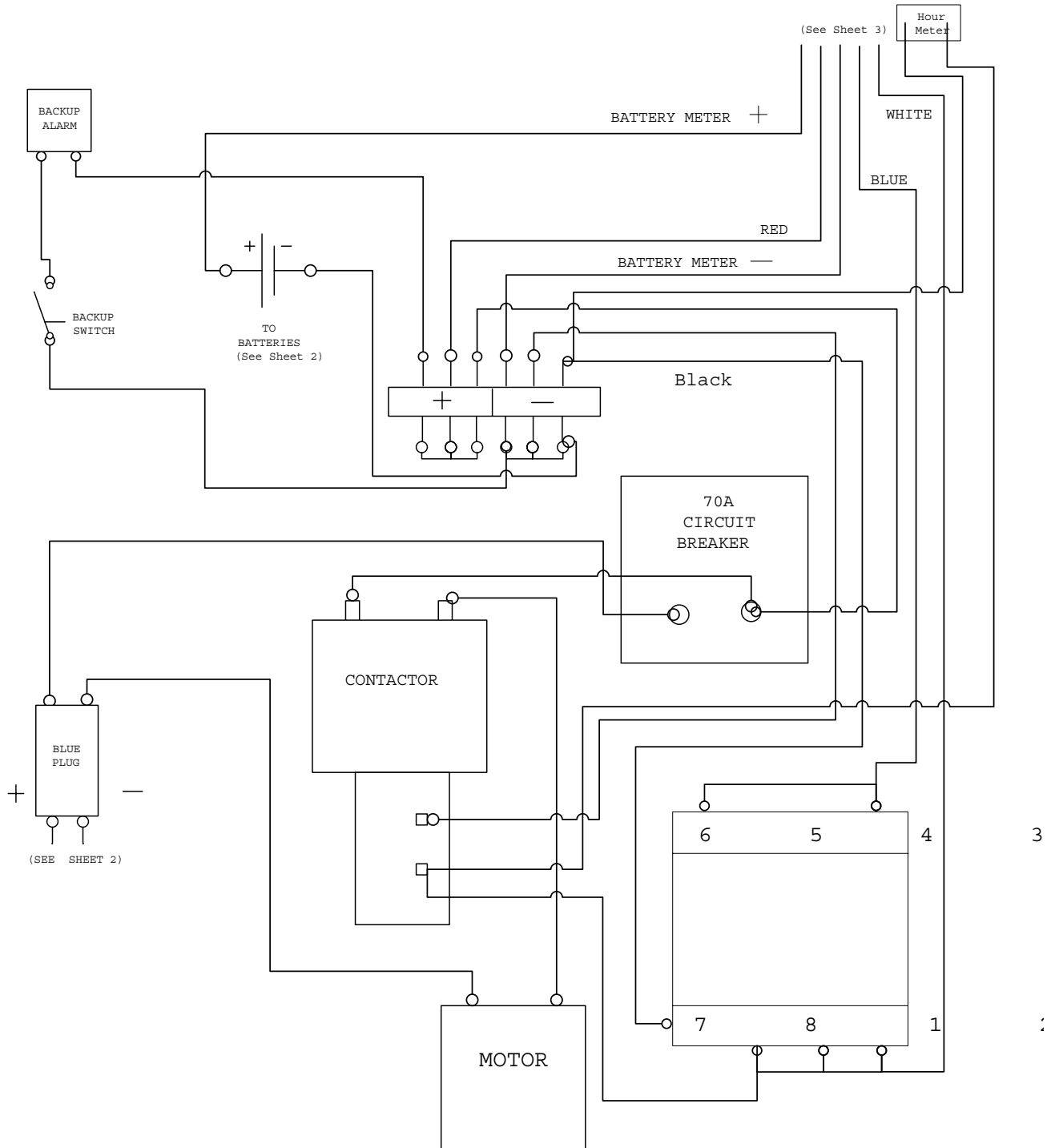

TILE BOX

PART #7074

The Tile Box works for wind rowing and assists for a fast clean-up and collection of tile debris for quick removal. High abrasion alloy for a long lasting edge. Resharpens just like a blade. 5" x 27" x 6" box. Attaches to the #7050-27 Cutting Head (required).



FRONT WHEEL ASSEMBLY

PART #5110-100

Allows stability and safe transportation over any surface. Easy and quick to attach.

5110-100W Replacement Wheel Only



CUTTING HEAD EXTENSION

PART #7050-15

Extension for cutting heads to reach under tight areas.



OPTIONAL ARM RESTS

PART #400321

Optional arm rests for added comfort. Set includes left and right arm rest and mounting hardware.



****PARTS ARE SOLD INDIVIDUALLY. PLEASE NOTE THE QUANTITY NEEDED WHEN ORDERING****

Parts List and Diagrams

HYDRAULIC SLIDE PLATE



PART #6701

Cutting head slide plate assembly is now available with hydraulic operation. Provides the operator the ability to adjust the height of the slide plate and allows precise angle adjustment of the cutting head with hydraulic hand control. No need to get off the machine, no lifting and no manual labor required to adjust the plate height. Adds 200 lbs of added weight to the front of the machine where it is most effective. Increases productivity by over 20%. Quick, simple and efficient hand control adjustments.

Material Safety Data Sheet (MSDS) Information

VALVE REGULATED (VRLA) BATTERIES - ABSORBED ELECTROLYTE (AGM)

PRODUCT IDENTIFICATION AND COMPANY IDENTIFICATION

Product Number(S): 5214-1, 5213-1, 5213-3

Chemical / Trade Name (Identity used on label):

Absorbed Electrolyte Battery/HGL,DC,HGHL Sealed Valve Regulated Lead-Acid Battery

Manufacturer's Name: Fullriver Battery Manufacture Co. Ltd.

Address: P.O. Box 511475, Taishi Industrial Area, Yuwotou Town, Panyu Zone, Guangzhou, China

Chemical Family / Classification: Electric Storage Battery

Date Revised: October 5th, 2010

Telephone: 86-20-84916671

Website: <http://www.fullriverdcbattery.com>

HAZARDOUS INGREDIENTS / IDENTIFY INFORMATION

NOTE: Inorganic lead and electrolyte (water and sulfuric acid solution) are the primary components of every battery manufactured by Fullriver Technologies or its subsidiaries. Other ingredients may be present dependent upon battery type.

MATERIALS / COMPONENTS	% BY WT.	CAS NUMBER	EXPOSURE LIMITS		
			OSHA	ACGIH	NIOSH
Specific Chemical Identity / Common Name INORGANIC LEAD / LEAD COMPOUNDS	65%-75%	7439-92-1	50 µg/m ³	150 µg/m ³	100 µg/m ³
Specific Chemical Identity / Common Name TIN	<0.5%	7440-31-5	2000 µg/m ³	2000 µg/m ³	NA
Specific Chemical Identity / Common Name CALCIUM	<0.2%	7440-70-2	NA	NA	NA
Specific Chemical Identity / Common Name SULFURIC ACID (40%)/BATTERY ELECTROLYTE (ACID)	16%-21%	7664-93-9	1 mg/m ³	1 mg/m ³	1 mg/m ³
Specific Chemical Identity / Common Name FIBERGLASS SEPARATOR	5%	-	NA	NA	NA
Specific Chemical Identity / Common Name ACRYLONITRILE BUTADIENE STYRENE (ABS)	5%-10%	9003-56-9	NA	NA	NA

FIRE AND EXPLOSION HAZARD DATA

Fire and Explosive Properties: Hydrogen Flash Point: N/A Hydrogen Auto Ignition Point: 580°C
Hydrogen Flammabl Limits in Air (% by Volume): LEL: 4.1 UEL: 74.2
Low Explosion Limit (LEL), Upper Explosion Limit (UEL)

Extinguishing Media: Dry Chemical, Foam, CO2

Special Fire Fighting Hazards: Use Positive Pressure, Self-Contained breathing apparatus.

Unusual Fire and Explosion Hazards:

If AGM batteries are properly charged they will not release any flammable hydrogen gas. If they are excessively overcharged the safety relief valve can open and release flammable hydrogen gas. They must always be assumed to contain this gas which, if ignited by burning cigarette, naked flame or spark, may cause battery explosion with dispersion of casing fragments and corrosive liquid electrolyte. Carefully follow manufacturer's instruction for installation and service. Keep away all sources of gas ignition and do not allow metallic articles to simultaneously contact the negative and positive terminals of a battery.

Material Safety Data Sheet (MSDS) Information

VALVE REGULATED (VRLA) BATTERIES - ABSORBED ELECTROLYTE (AGM)(CONT.)

HEALTH HAZARD INFORMATION

ROUTES OF ENTRY

Sulfuric Acid: Harmful by all routes of entry.

Lead Compounds: Hazardous exposure can occur only when product is heated, oxidized or otherwise processed or damaged to create dust, vapor or fumes.

INHALATION

Sulfuric Acid: Breathing of sulfuric acid vapors or mists may cause severe respiratory irritation.

Lead Compounds: Inhalation of lead dust or fumes may cause irritation of upper respiratory tract and lungs.

Fiberglass Separator: Fiberglass is an irritant to the upper respiratory tract, skin and eyes. For exposure up to 10F°/use MSA Comfall with type H filter. Above 10F° use Ultra Twin with type H filter. This product is not considered carcinogenic by NTP or OSHA.

INGESTION

Sulfuric Acid: May cause severe irritation of mouth, throat, esophagus and stomach.

Lead Compounds: Acute ingestion may cause abdominal pain, nausea, vomiting, diarrhea and severe cramping. This may lead rapidly to system toxicity and must be treated by a physician.

SKIN CONTACT

Sulfuric Acid: Severe irritation, burns and ulceration.

Lead Compounds: Not absorbed through the skin.

EYE CONTACT

Sulfuric Acid: Severe irritation, burns, cornea damage, and blindness.

Lead Compounds: May cause eye irritation.

EFFECTS OF OVEREXPOSURE - ACUTE

Sulfuric Acid: Severe skin irritation, damage to cornea, upper respiratory irritation.

Lead Compounds: Symptoms of toxicity include headache, fatigue, abdominal pain, loss of appetite, muscular aches and weakness, sleep disturbances and irritability.

EFFECTS OF OVEREXPOSURE - CHRONIC

Sulfuric Acid: Possible erosion of tooth enamel, inflammation of nose, throat and bronchial tubes. **Lead Compounds:** Anemia; neuropathy, particularly of the motor nerves, with wrist drop; kidney damage; reproductive changes in males and females.

CARCINOGENICITY

Sulfuric Acid: The International Agency for Research on Cancer (IARC) has classified "strong inorganic acid mist containing sulfuric acid" as a Category I carcinogen, a substance that is carcinogenic to humans. This classification does not apply to liquid forms of sulfuric acid or sulfuric acid solutions contained within a battery. Inorganic acid mist (sulfuric acid mist) is not generated under normal use of this product. Misuse of the product, such as overcharging, may result in the generation of sulfuric acid mist.

Lead Compounds: Lead is listed as a 2B carcinogen, likely in animals at extreme doses. Proof of carcinogenicity in humans is lacking at present.

MEDICAL CONDITIONS GENERALLY AGGRAVATED BY EXPOSURE

Overexposure to sulfuric acid mist may cause lung damage and aggravate pulmonary conditions. Contact of sulfuric acid with skin may aggravate diseases such as eczema and contact dermatitis. Lead and its compounds can aggravate some forms of kidney, liver and neurologic diseases.

Material Safety Data Sheet (MSDS) Information

VALVE REGULATED (VRLA) BATTERIES - ABSORBED ELECTROLYTE (AGM)(CONT.)

EMERGENCY AND FIRST AID PROCEDURES

INHALATION

Sulfuric Acid: Remove to fresh air immediately. If breathing is difficult, give oxygen.

Lead Compounds: Remove from exposure, gargle, wash nose and lips; consult physician.

INGESTION

Sulfuric Acid: Give large quantities of water; do not induce vomiting; consult physician.

Lead Compounds: Consult physician immediately.

PRECAUTIONS FOR SAFE HANDLING AND USE

HANDLING AND STORAGE

Store batteries in cool, dry, well-ventilated areas with impervious surfaces and adequate containment in the event of spills. Batteries should also be stored under roof for protection against adverse weather conditions. Separate from incompatible materials. Store and handle only in areas with adequate water supply and spill control. Avoid damage to containers. Keep away from fire, sparks and heat.

PRECAUTIONARY LABELING

POISON - CAUSES SEVERE BURNS DANGER - CONTAINS SULFURIC ACID

CHARGING

There is a possible risk of electric shock from charging equipment and from strings of series connected batteries, whether or not being charged. Shut-off power to chargers whenever not in use and before detachment of any circuit connections. If batteries are properly charged they will not release any flammable hydrogen gas. If they are excessively overcharged the safety relief valve can open and release flammable hydrogen gas. Charging space should be ventilated. Keep battery vent caps in position. Prohibit smoking and avoid creation of flames and sparks nearby. Wear face and eye protection when near batteries being charged.

SPILL OR LEAK PROCEDURES

Stop flow of material; contain/absorb small spills with dry sand, earth and vermiculite. Do not use combustible materials. If possible, carefully neutralize spilled electrolyte with soda ash, sodium bicarbonate, lime, etc. Wear acid-resistant clothing, boots, gloves, and face shield. Do not allow discharge of un-neutralized acid to sewer.

WASTE DISPOSAL METHOD

Spent batteries: Send to secondary lead smelter for recycling.

CONTROL MEASURES

ENGINEERING CONTROLS: Store and handle in well-ventilated area. If mechanical ventilation is used, components must be acid-resistant.

WORK PRACTICES: Handle batteries cautiously to avoid spills. Make certain vent caps are on securely. Avoid contact with internal components. Wear protective clothing when filling or handling batteries.

RESPIRATORY PROTECTION: None required under normal conditions. When concentrations of sulfuric acid mist are known to exceed the PEL, use NIOSH or MSHA-approved respiratory protection.

PROTECTIVE GLOVES: Rubber or plastic acid-resistant gloves with elbow-length gauntlet.

EYE PROTECTION: Chemical goggles or face shield.

OTHER PROTECTION: Acid-resistant apron. Under severe exposure emergency conditions, wear acid-resistant clothing and boots.

EMERGENCY FLUSHING: In areas where sulfuric acid is handled in concentrations greater than 1%, emergency eyewash stations and showers should be provided, with unlimited water supply.

Material Safety Data Sheet (MSDS) Information

VALVE REGULATED (VRLA) BATTERIES - ABSORBED ELECTROLYTE (AGM)(CONT.)

PHYSICAL DATA

ELECTROLYTE:

Boiling Point:	203-240°F	Specific Gravity (H₂O=1):	1.300-1.330
Melting Point:	N/A	Vapor Pressure (mm Hg):	10
Solubility in Water:	100%	Vapor Density (AIR = 1):	3.4
Evaporation Rate:	(Butyl Acetate = 1) Less than 1	% Volatile by Weight:	N/A

Appearance and Odor: Manufactured article; no apparent odor. Electrolyte is a clear liquid with a sharp, penetrating, pungent odor.

REACTIVITY DATA

Stability: Stable

Conditions to Avoid: High temperature, Sparks and other sources of ignition

INCOMPATIBILITY (MATERIALS TO AVOID)

Electrolyte (Water and Sulfuric Acid Solution): Contact with combustibles and organic materials may cause fire and explosion. Also reacts violently with strong reducing agents, metals, sulfuric trioxide gas, strong oxidizers, and water. Contact with metals may produce toxic sulfur dioxide fumes and may release flammable hydrogen gas.

Lead Compounds: Avoid contact with strong acids, bases, halides, halogenated, potassium nitrate, permanganate, peroxides, nascent hydrogen, and reducing agents.

HAZARDOUS BYPRODUCTS

Sulfuric Acid: Sulfur trioxide, carbon monoxide, sulfuric acid mist, sulfur dioxide, and hydrogen. **Lead Compounds:** High temperatures likely to produce toxic metal fume, vapor, or dust; contact with strong acid or base or presence of nascent hydrogen may generate highly toxic arsine gas.

ECOLOGICAL INFORMATION

Lead and its compounds can pose a threat if released into the environment.

TRANSPORT INFORMATION

All Fullriver AGM batteries, when transported by air, surface or by vessel are identified as “**Battery, Electric Storage, Wet, Nonspillable, Not Regulated**”.

The battery(s) must be identified as above on the Bill of Lading and properly packaged with their terminals protected from short circuit. NA or UN numbers do not apply.

Fullriver AGM battery(s) warning label identifies each battery as NONSPILLABLE.

Fullriver AGM battery(s) preprinted cartons identify each battery as NONSPILLABLE.

Fullriver AGM battery(s) shipped without Fullriver cartons (bulk packed) need to be identified as NONSPILLABLE or NONSPILLABLE BATTERY on the outer packaging.

Air: Fullriver AGM batteries meet the conditions in IATA/ICAO Special Provision A67.

Surface: Fullriver AGM batteries meet the conditions for DOT Haz Mat Regulations CFR-Title 49 parts 171-189.

Vessel: Fullriver Batteries meet the conditions of IMDG.

REGULATORY INFORMATION

See 29 CFR 1910.268(b)(2)

OTHER INFORMATION

The information herein is given in good faith, but no warranty, expressed or implied, is made.

Material Safety Data Sheet (MSDS) Information

CHEVRON HD 22 - 68 - HYDRAULIC FLUID

PRODUCT IDENTIFICATION AND COMPANY IDENTIFICATION

Product Number(S): CPS221655, CPS221658, CPS221659
Synonyms: Texaco Rando HD22, Texaco Rando HD 32, Texaco Rando HD 46, Texaco Rando HD 68

Company Information

Chevron Products Company
a division of Chevron U.S.A. Inc.
6001 Bollinger Canyon Road
San Ramon, CA 94583
United States of America
www.chevronlubricants.com

Transportation Emergency Response

CHEMTREC: (800) 424-9300 or (703) 527-3887

Health Emergency

Chevron Emergency Information Center: Located in the USA.

International collect calls accepted.

(800) 231-0623 or (510) 231-0623

Product Information

email: lubemsds@chevron.com

Product Information: 800-LUBE-TEK

MSDS Requests: 800-414-6737

HAZARDOUS INGREDIENTS / IDENTIFY INFORMATION

MATERIALS / COMPONENTS	CAS NUMBER	AMOUNT
HIGHLY REFINED MINERAL OIL (C15 - C50)	mixture	90-100% weight

HAZARDS IDENTIFICATION

IMMEDIATE HEALTH EFFECTS

Eye: Not expected to cause prolonged or significant eye irritation.

Skin: Contact with the skin is not expected to cause prolonged or significant irritation. Not expected to be harmful to internal organs if absorbed through the skin. High-Pressure Equipment Information: Accidental high-velocity injection under the skin of materials of this type may result in serious injury. Seek medical attention at once should an accident like this occur. The initial wound at the injection site may not appear to be serious at first; but, if left untreated, could result in disfigurement or amputation of the affected part.

Ingestion: Not expected to be harmful if swallowed.

Inhalation: Not expected to be harmful if inhaled. Contains a petroleum-based mineral oil. May cause respiratory irritation or other pulmonary effects following prolonged or repeated inhalation of oil mist at airborne levels above the recommended mineral oil mist exposure limit. Symptoms of respiratory irritation may include coughing and difficulty breathing.

FIRST AID MEASURES

Eye: No specific first aid measures are required. As a precaution, remove contact lenses, if worn, and flush eyes with water.

Skin: No specific first aid measures are required. As a precaution, remove clothing and shoes if contaminated. To remove the material from skin, use soap and water. Discard contaminated clothing and shoes or thoroughly clean before reuse.

Ingestion: No specific first aid measures are required. Do not induce vomiting. As a precaution, get medical advice.

Inhalation: No specific first aid measures are required. If exposed to excessive levels of material in the air, move the exposed person to fresh air. Get medical attention if coughing or respiratory discomfort occurs.

Note to Physicians: In an accident involving high-pressure equipment, this product may be injected under the skin. Such an accident may result in a small, sometimes bloodless, puncture wound. However, because of its driving force, material injected into a fingertip can be deposited into the palm of the hand. Within 24 hours, there is usually a great deal of swelling, discoloration, and intense throbbing pain. Immediate treatment at a surgical emergency center is recommended.

FIRE FIGHTING MEASURES

Leaks/ruptures in high pressure system using materials of this type can create a fire hazard when in the vicinity of ignition sources (eg. open flame, pilot lights, sparks, or electric arcs).

FIRE CLASSIFICATION: OSHA Classification (29 CFR 1910.1200): Not classified by OSHA as flammable or combustible.

NFPA RATINGS: Health: 0 Flammability: 1 Reactivity: 0

FLAMMABLE PROPERTIES:

Flashpoint: (Cleveland Open Cup) 150 C (302 F) (Min)

Autoignition: No Data Available

Flammability (Explosive) Limits (% by volume in the air): Lower: Not Applicable Upper: Not Applicable

Material Safety Data Sheet (MSDS) Information

CHEVRON HD 22 - 68 - HYDRAULIC FLUID (CONTINUED)

EXTINGUISHING MEDIA: Use water fog, foam, dry chemical or carbon dioxide (CO₂) to extinguish flames.

PROTECTION OF FIRE FIGHTERS: Fire Fighting instructions: This material will burn although it is not easily ignited. For fires involving this material, do not enter any enclosed or confined fire space without proper protective equipment, including self-contained breathing apparatus.

Combustion Products: Highly dependent on combustion conditions. A complex mixture of airborne solids, liquids, and gases including carbon monoxide, carbon dioxide, and unidentified organic compounds will be evolved when pounds will be evolved when this material undergoes combustion.

ACCIDENTAL RELEASE MEASURES

Protective Measures: Eliminate all sources of ignition in vicinity of spilled material.

Spill Management: Stop the source of the release if you can do it without risk. Contain release to prevent further contamination of soil, surface water or groundwater. Clean up spill as soon as possible, observing precautions in Exposure Controls/Personal Protection. Use appropriate techniques such as applying non-combustible absorbent materials or pumping. Where feasible and appropriate, remove contaminated soil. Place contaminated materials in disposable containers and dispose of in a manner consistent with applicable regulations.

Reporting: Report spills to local authorities and/or the U.S. Coast Guard's National Response Center at (800) 424-8802 as appropriate or required.

HANDLING AND STORAGE

Precautionary Measures: DO NOT USE IN HIGH PRESSURE SYSTEMS in the vicinity of flames, sparks and hot surfaces. Use only in well ventilated areas. Keep container closed.

General Handling Information: Avoid contaminating soil or releasing this material into sewage and drainage systems and bodies of water.

: Electrostatic charge may accumulate and create a hazardous condition when handling this material. To minimize this hazard, bonding and grounding may be a necessary but may not, by themselves, be sufficient. Review all operations which have the potential of generating and accumulating an electrostatic charge and/or a flammable atmosphere (including tank and container filling, splash filling, tank cleaning, sampling, gauging, switch loading, filtering, mixing, agitation, and vacuum truck operations) and use appropriate mitigating procedures. For more information, refer to OSHA standard 29 CFR 1910.106, 'Flammable and Combustible Liquids', National Fire Protection Association (NFPA 77, 'Recommended Practice on Static Electricity', and/or the American Petroleum Institute (API) Recommended Practice 2003, 'Protection Against Ignitions Arising Out of Static, Lightning, and Stray Currents'.

Container Warnings: Container is not designed to contain pressure. Do not use pressure to empty container or it may rupture with explosive force. Empty containers retain product residue (solid, liquid, and/or vapor) and can be dangerous. Do not pressurize, cut, weld, braze, solder, drill, grind, or expose such containers to heat, flame, sparks, static electricity, or other sources of ignition. They may explode and cause injury or death. Empty containers should be completely drained, properly closed, and promptly returned to a drum reconditioner or disposed of properly.

EXPOSURE CONTROLS/PERSONAL PROTECTION

GENERAL CONSIDERATIONS: Consider the potential hazards of this material (see Section 3), applicable exposure limits, job activities, and other substances in the workplace when designing engineering controls and selecting personal protective equipment. If engineering controls or work practices are not adequate to prevent exposure to harmful levels of this material, the personal protective equipment listed below is recommended. The user should read and understand all instructions and limitations supplied with the equipment since protection is usually provided for a limited time or under certain circumstances.

ENGINEERING CONTROLS: Use in a well-ventilated area.

PERSONAL PROTECTIVE EQUIPMENT

Eye/Face Protection: No special eye protection is normally required. Where splashing is possible, wear safety glasses with side shields as a good safety practice.

Skin Protection: No special protective clothing is normally required. Where splashing is possible, select protective clothing depending on operations conducted, physical requirements and other substances in the workplace. Suggested materials for protective gloves include: 4H (PE/EVAL), Nitrile Rubber, Silver Shield, Viton.

Respiratory Protection: No respiratory protection is normally required. If user operations generate an oil mist, determine if airborne concentrations are below the occupational exposure limit for mineral oil mist. If not, wear an approved respirator that provides adequate protection from measured concentrations of this material. For air-purifying respirators use a particulate cartridge. Use a positive pressure air-supplying respirator in circumstances where air-purifying respirators may not provide adequate protection.

Material Safety Data Sheet (MSDS) Information

CHEVRON HD 22 - 68 - HYDRAULIC FLUID (CONTINUED)

PHYSICAL AND CHEMICAL PROPERTIES

Attention: The data below are typical values and do not constitute a specification.

Color: Yellow

Physical State: Liquid

Odor: Petroleum odor

pH: Not applicable

Vapor Pressure: <0.01 mmHg @ 37.8 C (100 F)

Vapor Density (Air = 1): >1

Boiling Point: >315.6 C (600 F)

Solubility: Soluble in hydrocarbons; insoluble in water

Freezing Point: Not Applicable

Melting Point: Not Applicable

Specific Gravity: 0.86 - 0.87 @ 15.6 C (60.1 F) / 15.6 (60.1F)

Density: 0.86 kg/l - 0.9 kg/l @ 15 C (59 F)

Viscosity: 22 cSt - 61.2 cSt @40 C (104 F) (Min)

STABILITY AND REACTIVITY

Chemical Stability: This material is considered stable under normal ambient and anticipated storage and handling conditions of temperature and pressure.

Incompatibility With Other Materials: May react with strong acids or strong oxidizing agents, such as chlorates, nitrates, peroxides, etc.

Hazardous Decomposition Products: None known. (None expected)

Hazardous Polymerization: Hazardous polymerization will not occur.

TOXICOLOGICAL INFORMATION

IMMEDIATE HEALTH EFFECTS

Eye Irritation: The eye irritation hazard is based on evaluation of data for similar materials or product components.

Skin Irritation: The skin irritation hazard is based on evaluation of data for similar materials or product components.

Skin Sensitization: No product toxicology data available.

Acute Dermal Toxicity: The acute dermal toxicity hazard is based on evaluation of data for similar materials or product components.

Acute Oral Toxicity: The acute oral toxicity hazard is based on evaluation of data for similar materials or product components.

Acute Inhalation Toxicity: The acute inhalation toxicity hazard is based on evaluation of data for similar materials or product components.

ADDITIONAL TOXICOLOGY INFORMATION

This product contains petroleum base oils which may be refined by various processes including severe solvent extraction, severe hydrocracking, or severe hydrotreating. None of the oils requires a cancer warning under the OSHA Hazard Communication Standard (29 CFR 1910.1200). These oils have not been listed in the National Toxicology Program (NTP) Annual Report nor have been classified by the International Agency for Research on Cancer (IARC) as: carcinogenic to humans (Group 1), probably carcinogenic to humans (Group 2), or possibly carcinogenic to humans (Group 2B). These oils have not been classified by the American Conference of Governmental Industrial Hygienists (ACGIH) as: confirmed human carcinogen (A1), suspected human carcinogen (A2), or confirmed animal carcinogen with unknown relevance (A3).

ECOLOGICAL INFORMATION

ECOTOXICITY

This material is not expected to be harmful to aquatic organisms. The ecotoxicity hazard is based on an evaluation of data for the components of a similar material.

ENVIRONMENTAL FATE

This material is not expected to be readily biodegradable.

DISPOSAL CONSIDERATIONS

Use material for its intended purpose of recycle is possible. Oil collection services are available for used oil recycling or disposal. Place contaminated materials in containers and dispose of in a manner consistent with applicable regulations. Contact your sales representative or local environmental or health authorities for approved disposal or recycling methods.

TRANSPORT INFORMATION

The description shown may not apply to all shipping situations. Consult 49CFR, or appropriate Dangerous Goods Regulations, for additional description requirements (e.g., technical name) and mode-specific or quantity-specific shipping requirements.

DOT Shipping Description: PETROLEUM LUBRICATING OIL, NOT REGULATED AS A HAZARDOUS MATERIAL FOR TRANSPORTATION UNDER 49 CFR Additional Information: NOT HAZARDOUS BY U.S. DOT. ADR/RID HAZARD CLASS NOT APPLICABLE

IMO/IMDG Shipping Description: PETROLEUM LUBRICATING OIL; NOT REGULATED AS DANGEROUS GOODS FOR TRANSPORT UNDER THE IMDG CODE

ICAO/IATA Shipping Description: PETROLEUM LUBRICATING OIL; NOT REGULATED AS DANGEROUS GOODS FOR TRANSPORT UNDER ICAO

Material Safety Data Sheet (MSDS) Information

CHEVRON HD 22 - 68 - HYDRAULIC FLUID (CONTINUED)

REGULATORY INFORMATION

EPCRA 311/312 CATAGORIES:

1. Immediate (Acute) Health Effects: NO
2. Delayed (Chronic) Health Effects: NO
3. Fire Hazard: NO
4. Sudden Release of Pressure Hazard: NO
5. Reactivity Hazzard: NO

REGULATORY LISTS SEARCHED:

01-1=IARC Group1
01-2A=IARC Group 2A
01-2B=IARC Group 2
02=NTP Carcinogen
03=EPCRA 313
04=CA Proposition 65
05=MA RTK
06=NJ RTK

No components of this material were found on the regulatory lists above.

CHEMICAL INVENTORIES:

All components comply with the following chemical inventory requirments: AICS (Australia), DSL (Canada), ENCS (Japan), IECSC (China), KECl (Korea), PICCS (Philippines), TSCA (United States)

One or more components is listed on ELINCS (European Union). Secondary notification by the importer may be required.

NEW JERSEY RTK CLASSIFICATION:

Under the New Jersey Right-to-Know Act L. 1983 Chapter 315 N.J.S.A. 34:5A-1 et. seq., the product is to be identified as follows: PETROLEUM OIL (Hydraulic oil)

WHMIS CLASSIFICATION:

This product is not considered a controlled product according to the criteria of the Canadian Controlled Products Regulations.

OTHER INFORMATION

NFPA RATINGS: Health: 0 Flammability: 1 Reactivity: 0

HMIS RATINGS: Health: 1 Flammability: 1 Reactivity: 0

(0-Least, 1-Slight, 2-Moderate, 3-High, 4-Extreme, PPE:- Personal Protection Equipment Index recommendation,*-Chronic Effect Indicator). These values are obtained using the guidelines or published evaluations prepared by the National Fire Protection Association (NFPA) or the National Paint and Coating Association (for HMIS ratings).

LABEL RECOMMENDATION: Label Category: INDUSTRIAL OIL 1 - IND1

REVISION STATEMENT: This revision updates the following sections of this Material Safety Data Sheet:

Revision Date: January 15, 2007

ABBREVIATIONS THAT MAY HAVE BEEN USED IN THIS DOCUMENT:

TLV - Threshold Limit Value	TWA - Time weighted Average
STEL - Short-term Exposure Llimit	PEL - Permissible Exposure Limit
CAS - Chemical Abstract Service Number	IMD?IMDG - International Maritime Dangerous Goods Code
API - American Petroleum Institute	MSDS - Material Safety Data Sheet
ACGIH - American Confrence of Government Industrial Hygienists	CVX - Chevron
NFPA - National Fire Protection Association (USA)	DOT - Department of Transportation
NFPA - NationalToxicology Program(USA)	IARC - International Agency for Research on Cancer
OSHA - Occupational Safety and Health Administration	

Prepared according to the OSHA Hazard Communication Standard (29 CFR 1910.1200) and the ANSI MSDS Stanard (Z400.1) by the Chevron Energy Technology Company, 100 Chevron Way, Richmond, California 94802.

The above information is based on the data of which we are aware and is believed to be correct as of the date hereof. Since this information may be applied under conditions beyond our control and with which we may be unfamiliar and since data made available subsequent to the date hereof may suggest modifications of the information, we do not assume any responsibility for the results of its use. This information is furnished upon condition that the person receiving it shall make his own determintion of the suitability of the material for his particular purpose.

National Flooring Equipment, Inc. (National) warrants to the first consumer/purchaser that this National brand product (**5700 Ride-on Floor Scraper**), when shipped in its original container, will be free from defective workmanship and materials and agrees that it will, at its option, either repair the defect or replace the defective product or part thereof at no charge to the purchaser for parts or labor for the period(s) set forth below.

This warranty does not apply to any appearance items of the product, to the additional excluded items set forth below, or to any product, the exterior of which has been damaged or defaced, which has been subjected to misuse, abnormal service or handling, or which has been altered or modified in design or construction.

In order to enforce the rights under this limited warranty, the purchaser should follow the steps set forth below and provide proof of purchase to National.

The limited warranty described herein is in addition to whatever implied warranties may be granted to purchasers by law. ALL IMPLIED WARRANTIES INCLUDING THE WARRANTIES OF MERCHANTABILITY AND FITNESS FOR USE ARE LIMITED TO THE PERIODS FROM THE DATE OF PURCHASE AS SET FORTH BELOW. Some states do not allow time limitations on an implied warranty, so the above limitation may not apply to you.

Neither the sales person of the seller, nor any other person, is authorized to make any other warranties other than those described herein, or to extend the duration of any warranties beyond the time period described herein on behalf of National.

The warranties described herein shall be the sole and exclusive warranties granted by National and shall be the sole and exclusive remedy available to the purchaser. Correction of defects in the manner and for the period of time described herein, shall constitute complete fulfillment of all liabilities and responsibilities of National to the purchaser with respect to the product and shall constitute full satisfaction of all claims, whether based on contract, negligence, strict liability or otherwise. In no event shall National be liable, or in any way responsible for any damage or defects in the product which were caused by repairs or attempted repairs performed by anyone other than National. Nor shall National be liable, or in any way responsible, for any incidental or consequential, economics or property damage. Some states do not allow the exclusion of incidental or consequential damages, so the above exclusion may not apply to you.

THIS WARRANTY GIVES YOU SPECIFIC LEGAL RIGHTS. YOU MAY ALSO HAVE OTHER RIGHTS WHICH VARY FROM STATE TO STATE.

WARRANTY PERIOD

The **5700 Ride-on Floor Scraper** is guaranteed to be free of manufacturer defective workmanship and in quality of materials for a period of one year.

Items excluded from warranty coverage, unless found and reported defective immediately upon removal from the original shipping container and before being used by the original purchaser.

A freight damage claim must be filed with the carrier by the purchaser, the shipper cannot file the freight claim.

TO OBTAIN SERVICE CONTACT NATIONAL FLOORING EQUIPMENT, INC. TOLL FREE AT 800-245-0267 FOR A REPAIR AUTHORIZATION NUMBER. COD FREIGHT RETURNS WILL NOT BE ACCEPTED. FREIGHT COLLECT SHIPMENTS WILL NOT BE ACCEPTED. WARRANTY REPAIRS MUST BE ACCOMPANIED BY DATE OF PURCHASE RECEIPT AND A RETURN/REPAIR AUTHORIZATION NUMBER.

RETURN/REPAIR AUTHORIZATION NUMBER: _____

MACHINE SERIAL NUMBER: _____



9250 XYLON AVENUE N • MINNEAPOLIS, MN 55445 • U.S.A.
TOLL-FREE 800-245-0267 • PHONE 763-315-5300 • FAX 800-648-7124 • FAX 763-535-8255
WEB SITE: www.nationalequipment.com • E-MAIL: info@nationalequipment.com

080813