

6280 COMMANDER WALK-BEHIND SCRAPER

SERVICE MANUAL



Read Manual Before Servicing Machine

402963 Rev E

Table of Contents

Table of Contents	3
Specifications	4
Safety	5
General Rules for Safe Operation	5
Walk-Behind Scraper Safety Guidelines	6
Hydraulic Safety Tips	7
Maintenance Schedule	10
Troubleshooting Guide	11
Maintenance	8
Wheel Cleaner Adjustment	8
Wheel Removal	8
Adding/Changing Hydraulic Fluid	8
Inspection of Internal Parts	8
Tank Removal	9
Control Valve Replacement	9
Power Cord	9
Isolators	9
Cutting Head Bearing	9
Parts List and Diagrams	12
External	12
Tank	13
Motor	14
Pump	14
Body	15
Idler Mount	15
Weights	16
Front Wheel Assembly	16
Cutting Head	17
Bottom and Back Cover	18
Wheels	18
Eccentric, Chain, and Belt	19
Hydraulic Motor	19
Base	20
Upper Handle Assembly	21
Hydraulic Hoses	22
Lower Sub-Assembly	22
Lever and Weldment	23
Front Cover	24
Knob	25
Adjustment Rod	25
115V Wiring	26
Hydraulics	27
Warranty	28

Specifications

Product Specifications										
Width	Length (Handle Folded)	Height	Weight	Speed	RPM	HP	Amps (full load)	Vibration		
								X Axis	Y Axis	Z Axis
17.75" (451 mm)	29" (736.6 mm)	46" (1,168 mm) (max. height) 30" (762 mm) (handle folded)	334 lbs (151.5 kg) (machine only) 424 lbs (192.3 kg) (with weights)	10-45 ft/min (USA only) 0-20 m/min	3450	1.5	13	3.2 m/s ²	6.3 m/s ²	4.8 m/s ²

Differences Between Machine Models			
Region	Serial Number	Input Power	Body Panels
Domestic	6280-COM-10XXXX	120V / 60 Hz	Silver Vein
	6280-COM-23XXXX	120V / 60 Hz	Silver Vein
	6280-COM-12XXXX	120V / 60 Hz	Green
International	6280-COM-11XXXX	230V / 50 Hz	Silver Vein
	6280-COM-15XXXX	230V / 50 Hz	Orange
	6280-COM-20XXXX	110V / 50 Hz	Silver Vein
	6280-COM-13XXXX	230V / 50 Hz	Silver Vein
	6280-COM-26XXXX	230V / 50 Hz	Silver Vein
	6280-COM-28XXXX	100V / 50/60 Hz	Silver Vein

GENERAL RULES FOR SAFE OPERATION

Before use, anyone operating or performing maintenance on this equipment must read and understand this manual, as well as any labels packaged with or attached to the machine and its components. Read the manual carefully to learn equipment applications and limitations, as well as potential hazards associated with this type of equipment. Keep manual near machine at all times. If your manual is lost or damaged, contact National Flooring Equipment (NFE) for a replacement.

Personal

Dress properly and use safety gear.

Do not wear loose clothing; it may be caught in moving parts. Anyone in the work area must wear safety goggles or glasses, hearing protection during extended use, and a dust mask for dusty operations. Hard hats, face shields, safety shoes, etc. should be worn when specified or necessary.

Maintain control; stay alert.

Keep proper footing and balance, and maintain a firm grip. Observe surroundings at all times and use common sense. Do not use when tired, distracted, or under the influence of drugs, alcohol, or any medication that may cause decreased control.

Keep hands away from all moving parts and tooling.

Wear gloves when changing tooling. Remove tooling when machine is not in use and/or lower cutting head to the floor.

Do not force equipment.

Equipment will perform best at the rate for which it was designed. Excessive force only causes operator fatigue, increased wear, and reduced control.

Environment

Avoid use in dangerous environments.

Do not use in rain, damp or wet locations, or in the presence of explosive atmospheres (gaseous fumes, dust, or flammable materials). Remove materials or debris that may be ignited by sparks. Keep work area tidy and well-lit - a cluttered or dark work area may lead to accidents. Extreme heat or cold may affect performance.

Protect others in the work area and be aware of surroundings.

Provide barriers or shields as needed to protect others from debris and machine operation. Children and other bystanders should be kept at a safe distance from the work area to avoid distracting the operator and/or coming into contact with the machine. Operator should be aware of who is around them and their proximity. Support personnel should never stand next to, in front of, or behind the machine while the machine is running. Operator should look behind them before backing up.

Do not come within 3 ft. of the machine's perimeter during operation.

Guard against electric shock.

Ensure that machine is connected to a properly grounded outlet. Prevent bodily contact with grounded surfaces, e.g. pipes, radiators, ranges, and refrigerators. When scoring or making cuts, always check the work area for hidden wires or pipes.

Maintenance & Repairs

Begin maintenance work only when the machine is shut down, unplugged, and cooled down.

Use proper cleaning agents.

Ensure that all cleaning rags are fiber-free; do not use any aggressive cleaning products.

Schedule regular maintenance check-ups.

Ensure machine is properly cleaned and serviced. Remove all traces of oil, combustible fuel, or cleaning fluids from the machine and its connections and fittings. Retighten all loose fittings found during maintenance and repair work. Loose or damaged parts should be replaced immediately; use only NFE parts.

Do not weld or flame-cut on the machine during repairs, or make changes to machine without authorization from NFE.

Equipment

Use proper parts and accessories.

Only use NFE-approved or recommended parts and accessories. Using any that are not recommended may be hazardous.

Ensure accessories are properly installed and maintained.

Do not permanently remove a guard or other safety device when installing an accessory or attachment.

Inspect for damaged parts.

Check for misalignment, binding of moving parts, loose fasteners, improper mounting, broken parts, and any other conditions that may affect operation. If abnormal noise or vibration occurs, turn the machine off immediately. Do not use damaged equipment until repaired. Do not use if power switch does not turn machine on and off. For all repairs, insist on only identical NFE replacement parts.

Maintain equipment and labels.

Keep handles dry, clean, and free from oil and grease. Keep cutting edges sharp and clean. Follow instructions for lubricating and changing accessories. Motor and switches should be completely enclosed at all times with no exposed wiring. Inspect cord regularly. Labels carry important information; if unreadable or missing, contact NFE for a free replacement.

Avoid accidental starting; store idle equipment.

When not in use, ensure that the machine is unplugged; do not turn on before plugging in. Store in a dry, secured place. Remove tooling when storing, and keep away from children.



CAUTION! ENSURE PROPER USE OF EXTENSION CORDS. IF AMP DRAW IS HIGHER THAN SHOWN ON TABLE OR CORD IS LONGER THAN 50 FT, SEE AN ELECTRICIAN.

ASSUMPTIONS: 3% ALLOWABLE VOLTAGE DROP, COPPER CONDUCTORS RATED FOR 75°C, 1.25 SAFETY FACTOR, CORD VOLTAGE RATING OF 600VAC, PROPER CORD TYPES (STO, STOW, SOOW).

Amp Draw	Gauge
0-12	14
13-16	12
14-24	10
25-40	8

Safety

WALK-BEHIND SCRAPER SAFETY GUIDELINES

Before use, anyone operating this equipment must read and understand these safety instructions.

Scraping

Beware of hidden obtrusions.

Watch out for hidden dangers and protrusions in flooring. Do not use on largely uneven surfaces.

Observe location of electrical supplies and extension cords.

Do not allow cutting heads to come into contact with any electrical supply or extension cord.

Use correct tooling and accessories.

Provide barriers or shields as needed to protect others from debris. After mounting tooling, check for proper alignment.

Use for correct applications.

Do not force equipment to do heavier duty work than it was made for.



WARNING: GRINDING/CUTTING/DRILLING OF MASONRY, CONCRETE, METAL AND OTHER MATERIALS CAN GENERATE DUST, MISTS AND FUMES CONTAINING CHEMICALS KNOWN TO CAUSE SERIOUS FATAL INJURY OR ILLNESS, SUCH AS RESPIRATORY DISEASE, CANCER, BIRTH DEFECTS OR OTHER REPRODUCTIVE HARM. IF YOU ARE UNFAMILIAR WITH THE RISKS ASSOCIATED WITH THE PARTICULAR MATERIAL BEING CUT, REVIEW THE MATERIAL SAFETY DATA SHEET AND/OR CONSULT YOU EMPLOYER, THE MATERIAL MANUFACTURER/SUPPLIER, GOVERNMENTAL AGENCIES SUCH AS OSHA AND NIOSH AND OTHER AUTHORITIES ON HAZARDOUS MATERIALS. CALIFORNIA AND SOME OTHER AUTHORITIES, FOR INSTANCE, HAVE PUBLISHED LISTS OF SUBSTANCES KNOWN TO CAUSE CANCER, REPRODUCTIVE TOXICITY, OR OTHER HARMFUL EFFECTS. CONTROL DUST, MIST AND FUMES AT THE SOURCE WHERE POSSIBLE. IN THIS REGARD USE GOOD WORK PRACTICES AND FOLLOW THE RECOMMENDATIONS OF THE MANUFACTURER/SUPPLIER, OSHA/NIOSH, AND OCCUPATIONAL AND TRADE ASSOCIATIONS. WHEN THE HAZARDS FROM INHALATION OF DUST, MISTS AND FUMES CANNOT BE ELIMINATED, THE OPERATOR AND ANY BYSTANDERS SHOULD ALWAYS WEAR A RESPIRATOR APPROVED BY OSHA/MSHA FOR THE MATERIAL BEING CUT.

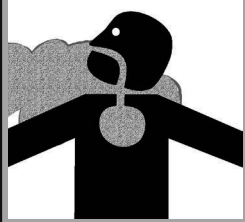

Safety

HYDRAULIC SAFETY

Maintaining a Safe Work Environment

Establishing a safe work environment in and around your hydraulic equipment is extremely important. The easiest and most effective way to avoid problems is to make sure associates understand their equipment, know how to operate the machines safely, and recognize the dangers if handled carelessly. A few things to be aware of are:

- **Pressure:** Hydraulic fluid under pressure is dangerous and can cause serious injury. Never look for a leak when unit is under pressure. Using your hand could cause serious injury. A few common ways to encounter hydraulic fluid under pressure include:
 - Pinhole: Fluid under pressure can cause serious injury. It can be almost invisible escaping from a pinhole, and it can pierce the skin into the body.



DANGER: DO NOT TOUCH A PRESSURIZED HYDRAULIC HOSE ASSEMBLY WITH ANY PART OF THE BODY. IF FLUID PUNCTURES THE SKIN, EVEN IF NO PAIN IS FELT, A SERIOUS EMERGENCY EXISTS. OBTAIN MEDICAL ASSISTANCE IMMEDIATELY. FAILURE TO DO SO COULD RESULT IN LOSS OF THE INJURED BODY PART OR DEATH.

- Leak: Keep fittings and hoses tight. Only check and service when not under pressure. Leaking hydraulic fluid is hazardous; in addition to making workplace floors slippery and dangerous, it also contaminates the environment. Before cleaning an oil spill, always check EPA, state, and local regulations.
- Burst: Whether due to improper selection or damage, a ruptured hose can cause injury. If it bursts, a worker can be burned, cut, injected, or may slip and fall.
- Coupling Blow-Off: If the assembly is not properly made or installed, the coupling could come off and hit or spray a worker, possibly resulting in serious injury. Never operate machine without guards.
- **Flammability:** When ignited, some hydraulic fluids can cause fires and/or explode. With the exception of those comprised primarily of water, all hydraulic fluid is flammable (including many “fire-resistant” hydraulic fluids) when exposed to the proper conditions. Leaking pressurized hydraulic fluids may develop a mist or fine spray that can flash or explode upon contact with a source of ignition. These explosions can be very severe and could result in serious injury or death. Precautions should be taken to eliminate all ignition sources from contact with escaping fluids, sprays or mists resulting from hydraulic failures. Sources of ignition could be electrical discharges (sparks), open flames, extremely high temperatures, sparks caused by metal-to-metal contact, etc.



CAUTION: NEVER USE YOUR HANDS TO CHECK FOR LEAKS OVER HOSE OR HYDRAULIC CONNECTIONS. USE A PIECE OF CARDBOARD TO LOCATE A PRESSURIZED LEAK. FOR LOW PRESSURE LEAKS (DRIPS), USE A RAG TO CLEAN THE AREA AND DETERMINE WHERE THE LEAK ORIGINATES.

- **Mechanical:** Hydraulic fluid creates movement, which means some equipment may move. Observe surroundings and equipment at all times.
- **Moisture:** Do not use in wet or high moisture conditions.
- **Electrical:** Faulty wiring can be an electrical hazard. A regular preventive maintenance program should always include a wiring check. If applicable, disconnect battery before servicing.
- **Temperature:** Because this machine operates at a relatively low pressure, overheating is not common. If surface of tank becomes too hot to touch by hand (above 130°F or 55°C), shut off machine and allow it to cool.

Hydraulic Fluid

Only use Texaco Rando 46 Hydraulic Oil or compatible fluid like ISO or AW #46 from a brand name manufacturer. Non-compatible fluids could cause damage to unit or serious injury.

Maintenance



WARNING: ALWAYS UNPLUG MACHINE BEFORE PERFORMING MAINTENANCE.

WHEEL CLEANER ADJUSTMENT

1. Loosen wheel cleaner with 9/16" wrench (Figure 1).
2. Slide cleaner up to the face of the wheel until it touches, but does not dig into the wheel surface.
3. Re-tighten firmly. **Note:** Too much interference between the wheel and cleaner will damage wheel.

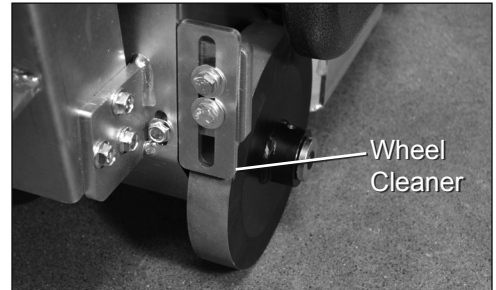

FIG. 1

WHEEL REMOVAL

1. Turn off and unplug machine.
2. Examine back of wheels for built-up debris.
3. Remove yarn build-up.
4. Lay machine on its side.
5. Disengage and remove axle pin (Figure 2).
6. Remove wheel-securing screw with a 3/16" Allen wrench (Figure 2).
7. Remove wheel-securing cap. Wheel will slide off.
8. Remove wheel spacer. This should be inspected at regular intervals.

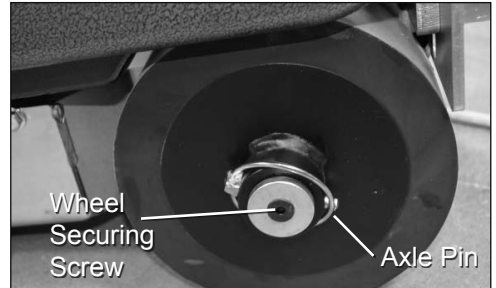

FIG. 2

ADDING OR CHANGING HYDRAULIC FLUID

- Change or add fluid when needed; check fluid level if there has been a leak, damaged or ruptured hose, or a loose fitting. Fluid should be level with bottom of tank plug hole (Figure 3).
- **To add fluid**, unscrew filler port cap from top of machine (Figure 4); add fluid through a filter or funnel with a screen to keep fluid clean.
- **To change fluid**, remove filler port cap. Remove drain plug from side of machine (Figure 4). A two gallon container will be needed to drain the fluid into. (Fluid will not be removed from hoses.) Regardless of the machine's straining system, add fluid through a filter or funnel with a screen to keep fluid clean.



FIG. 3

INSPECTION OF INTERNAL PARTS

Visual inspection of internal parts can be done without draining the tank.

1. Remove two lifting bail eyebolts and the two bolts from the back of the tank.
2. Carefully lift tank 3-4" (8-10 cm).
3. Using a flashlight, inspect the drive chain, hoses, front seal on hydraulic motor, and suction and pressure line on pump.
4. If service is necessary, follow the procedure for tank removal.



FIG. 4

Note: Figures 1-4 are shown without sliding side weights for clarity.

TANK REMOVAL

It is necessary to remove the tank in order to repair the pump, or to replace or service internal hoses.

1. Drain tank by removing the top filler port cap and drain plug on the side of the machine (Figure 12). A two gallon container will be needed to drain the fluid into.
2. Replace drain plug and filler port cap.
3. Remove two lifting bail eyebolts and the two bolts from the back of the tank.
4. Disconnect return line on the back of the tank; carefully lift tank 3-4" (8-10 cm) and disconnect suction line. The tank can now be removed.

POWER CORD

If the power cord is damaged, it must be replaced by NFE or a qualified professional.

ISOLATORS

Inspection

1. Perform the wheel removal procedure to access the bottom cover.
2. Remove one wheel at a time; remove the bottom cover bolt behind each wheel.
3. Carefully remove the bottom cover to expose the underside.
4. Inspect the isolators from the side for damage or wear.

Replacement

1. Remove the side slide weights, side weights, and front weight.
2. Loosen the top five hex head bolts holding the isolators in place. Grip each isolator with locking pliers to aid in loosening.
3. Remove and replace each isolator.

CUTTING HEAD BEARING

Inspection

1. Perform the wheel removal procedure to access the bottom cover.
2. Remove one wheel at a time; remove the bottom cover bolt behind each wheel.
3. Carefully remove the bottom cover to expose the underside.
4. Inspect the cutting head bearing for damage or wear.

Replacement

1. Remove the bottom cover.
2. Remove the cutting head bearing from the bottom cover by removing the four bolts that hold down the bearing.
3. Replace the cutting head bearing and re-tighten the four bolts.
4. Place the bottom cover and re-tighten the eight bolts that hold the bottom cover in place.

Maintenance

Maintenance to be performed	Interval			
	Daily	50 hrs	1000 hrs	2000 hrs
Inspect fasteners, wheels and blade holders for damage.	•			
Clean built-up glue and debris from wheels, front weight, and blade holder.	•			
Visually inspect internal parts.		•		
Inspect safety devices and switches (power cord, wheel cleaners, switches).		•		
Inspect and replace isolators.			•	
Inspect and replace cutting head bearing.			•	
Change hydraulic fluid.				• ○

○ - Perform maintenance at least once a year

Troubleshooting Guide

Problem	Cause	Solution
Machine will not start.	Insufficient power.	Ensure use of properly rated extension cord.
	Loose capacitor leads.	Check capacitor leads to ensure good connection.
	Overload button on motor has been tripped.	Button is located on the bottom of the electric box on motor. If tripped, hold button in until it clicks.
	Faulty ON/OFF switch.	Replace if needed.
Machine will not move under power.	Wheels are not in the "engage mode."	Install wheel pins for "engage mode."
	Broken belt.	Remove wheels and bottom cover to inspect. Replace if needed.
	Broken chain.	Remove wheels and bottom cover to inspect; repair or replace if needed.
	Control handle mechanism failure.	Inspect control mechanism; repair or replace as needed.
Motor is humming, but machine does not run or breakers are blown.	Failed isolators.	Remove wheels and bottom cover to inspect.
	Failed capacitors.	Replace as needed.
	Motor start switch connections are dirty.	Remove fan cover and fan. Clean the motor start switch (set of points) with an emery board or cloth between the points; reassemble.
Machine is leaking hydraulic fluid.	Leak in hose(s).	Tighten; replace if needed.
	Hydraulic fittings are loose.	Tighten; replace if needed.
Motor is heating up.	Motor shaft is binding.	Remove wheels and cover to inspect isolators. Inspect cutting head bearing and eccentric to ensure that they are not binding. If issue continues, contact NFE for additional support.

Parts List and Diagrams

EXTERNAL

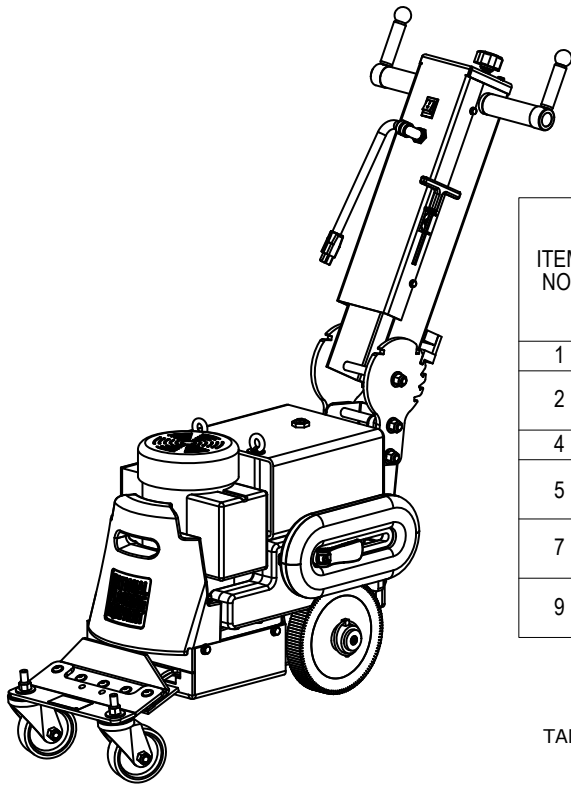

ITEM NO.	6280-10XXXX 6280-12XXXX 6280-23XXXX	6280-11XXXX 6280-13XXXX 6280-15XXXX 6280-20XXXX 6280-26XXXX 6280-28XXXX	DESCRIPTION	QTY
1	401546	401546	Motor, Hydraulic, Sub, 6280	1
2	401577	400025	Assembly, Commander Handle, 115V	1
			Assembly, Commander Handle, 230V	
4	6280-299	6280-299	Wheel Assembly, Front	1
5	6280-401B	5280-137W	Wrench, Allen, 7/32	1
			Wrench, Blade	
7	6280S-BASEASSY	401639	Subassembly, Base, 6280, 7 Isolators	1
			Subassembly, Base, 6280, Metric	
9	73222	74650	Bolt, Flange 3/8-16 x 1	3
			Bolt, Hex Flange M10-25	

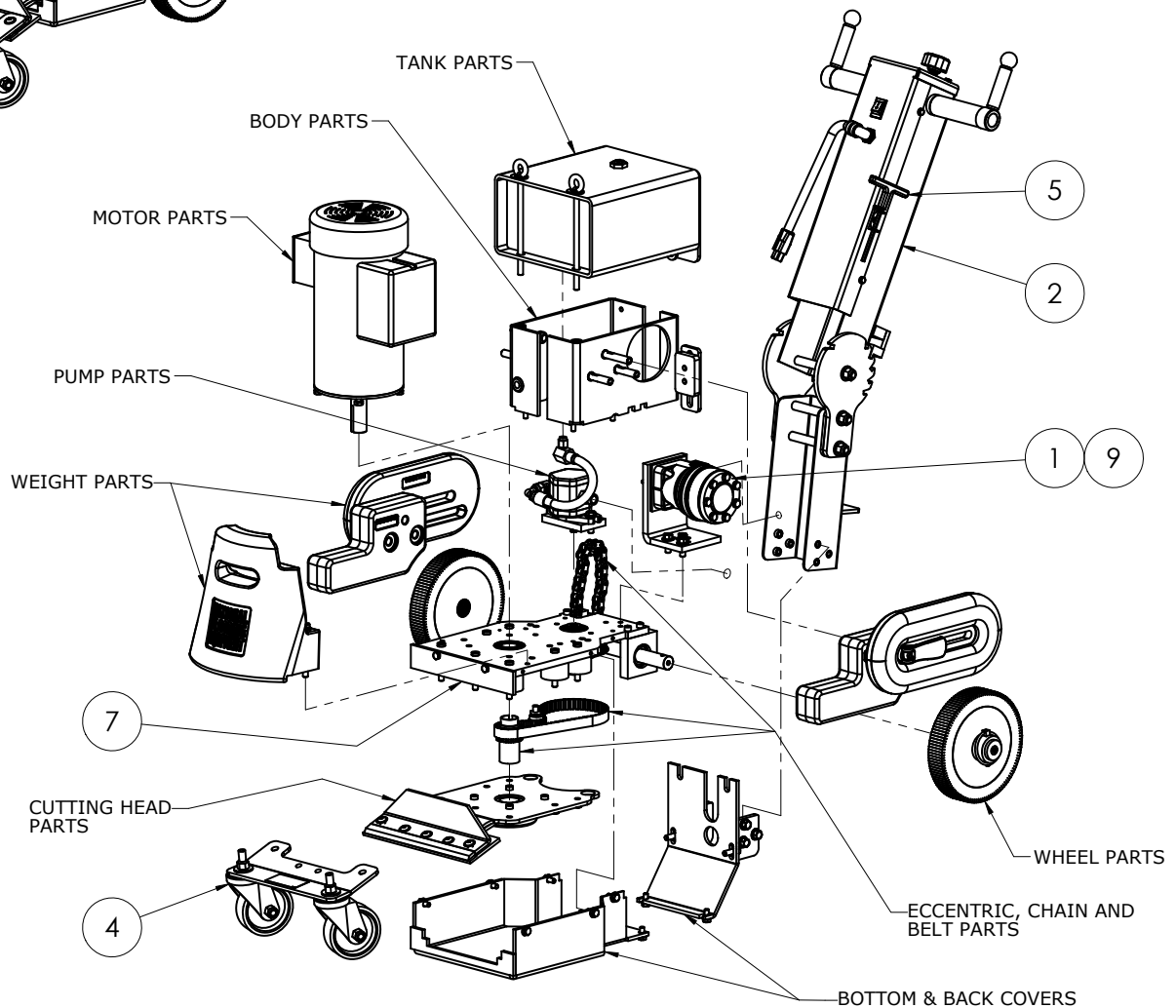

Parts List and Diagrams

TANK

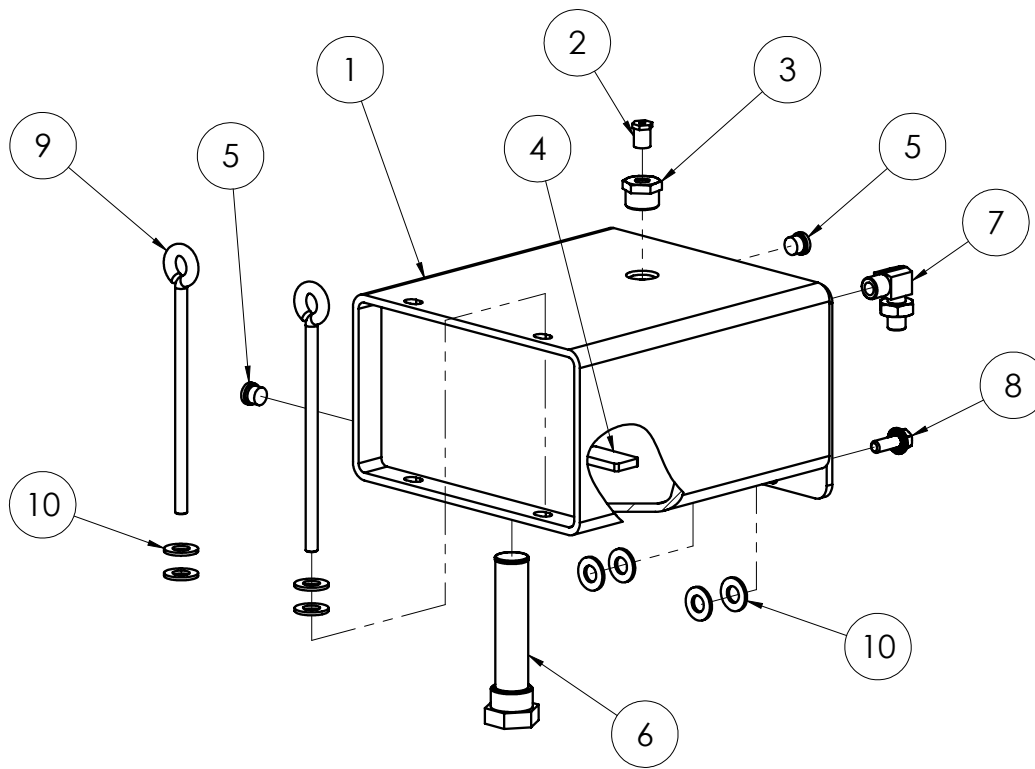

ITEM NO.	6280-10XXXX 6280-11XXXX 6280-13XXXX 6280-20XXXX 6280-23XXXX 6280-26XXXX 6280-28XXXX	6280-12XXXX	6280-15XXXX	DESCRIPTION	QTY.
1	6280-162-SV	6280-162-G	6280-162-O	Tank, Hydraulic, Weldment, Green Tank, Hydraulic, Weldment, Orange Tank, Hydraulic, Weldment, Silver Vein	1
2	6280-161B	6280-161B	6280-161B	Plug, Vent, Filler Cap	1
3	6280-161D	6280-161D	6280-161D	Plug, Filler Port	1
4	6280-162G	6280-162G	6280-162G	Magnet, Tank	1
5	6280-214	6280-214	6280-214	Plug, Tank	2
6	70601	70601	70601	Strainer, Tank Mounted	1
7	72816	72816	72816	Fitting, Elbow, 90 Deg. 3/8	1
8	73222	73222	73222	Bolt, Flange 3/8-16 x 1	2
9	73228	73228	73228	Eye Bolt, 3/816x8	2
10	401452	401452	401452	Washer, Flat, 1/2", SAE	8

Parts List and Diagrams

MOTOR

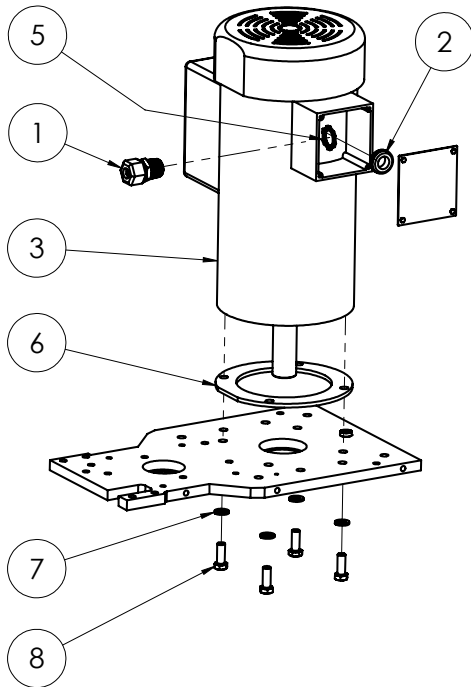

ITEM NO.	6280-10XXXX 6280-12XXXX 6280-23XXXX	6280-11XXXX 6280-13XXXX 6280-15XXXX 6280-20XXXX 6280-26XXXX 6280-28XXXX	DESCRIPTION	QTY.
1	73502	73502	Strain Relief, Straight 1/2 in	1
2	74730	74730	Grommet, Rubber 5/8"	1
3	72365		Motor, 1-1/2 HP 115 Volt	1
		72367W	Motor, 230V, 1.5 HP, 116943	
5	73401		Nut, Strain Relief, Steel, 1/2"	1
6	6280-179	6280-179	Ring, Motor Spacer	1
7	73204	73204	Washer, Lock, 3/8	4
8	73201	73201	Screw, Hex Head Cap, 3/8-16 x 1	4
9*	72810	72810	Caps, Splice	3
10*	72811	72811	Caps, Insulator, Splice	3
11*	72821	72821	Terminal, Ring, 16-14 Gauge, Nylon, 10 Stud	1

*NOT SHOWN

PUMP

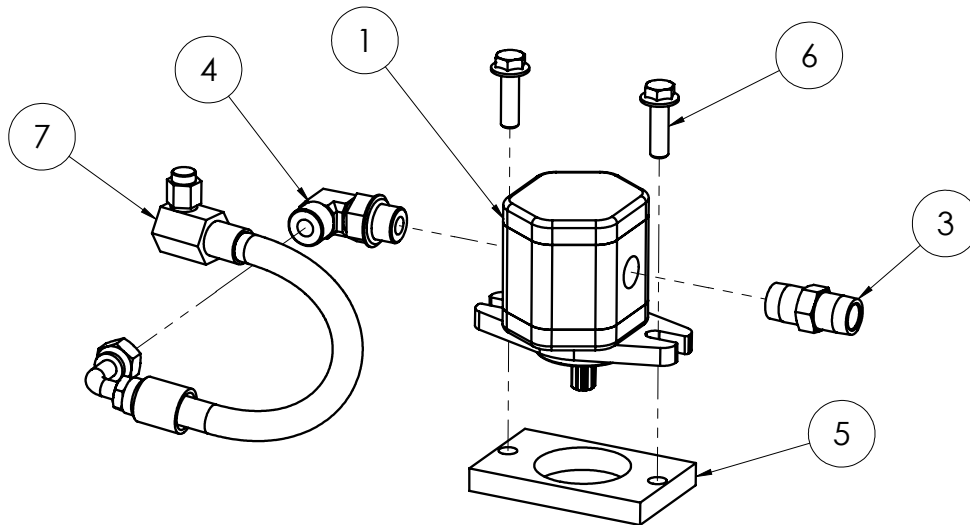

ITEM NO.	6280-10XXXX 6280-12XXXX	6280-11XXXX 6280-13XXXX 6280-15XXXX 6280-20XXXX 6280-26XXXX 6280-28XXXX	DESCRIPTION	QTY.
1	6280-113S		Pump, Spline #4	1
		70925	Pump, Hydraulic, Single, #7, Splined	
3	6280-117	6280-117	Fitting, Pump	1
4	6280-118	6280-118	Fitting, Suction Hose to Pump	1
5	6280-119	6280-119	Spacer, Pump	1
6	73223	73223	Bolt, Flange 3/8-16x1-1/4	2
7	6280-120	6280-120	Suction Hose	1

Parts List and Diagrams

BODY

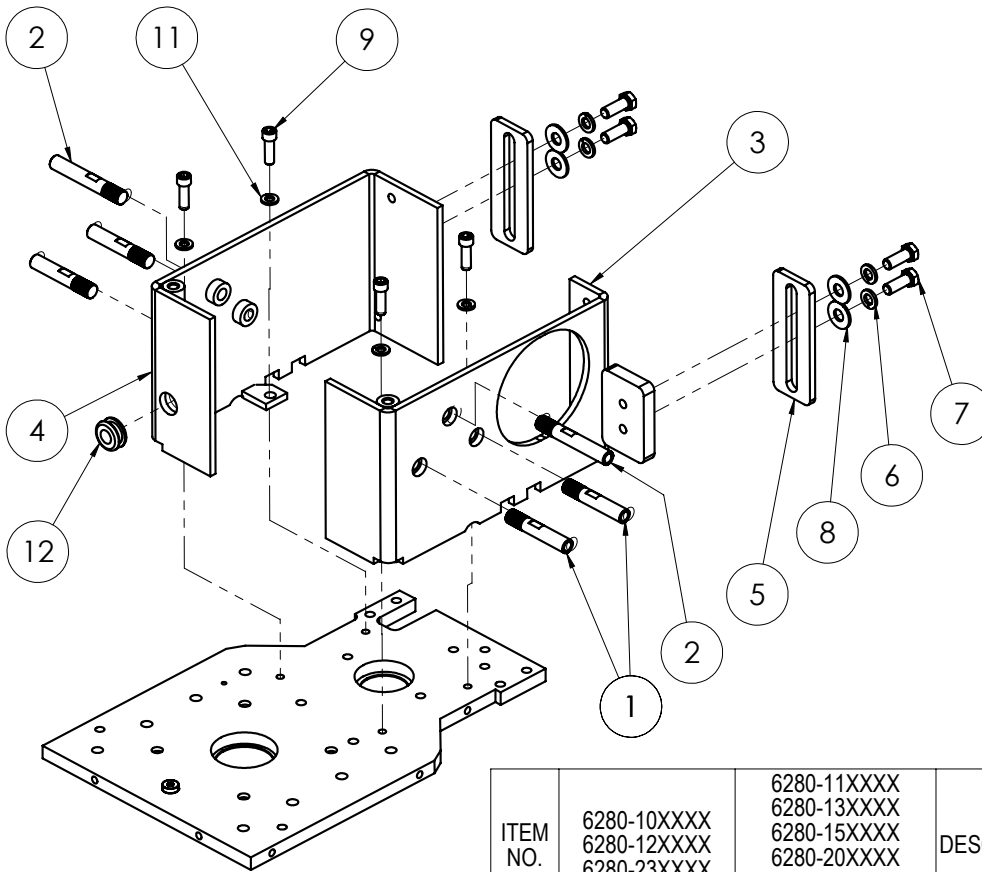

ITEM NO.	6280-10XXXX 6280-12XXXX 6280-23XXXX	6280-11XXXX 6280-13XXXX 6280-15XXXX 6280-20XXXX 6280-26XXXX 6280-28XXXX	DESCRIPTION	QTY.
1	400061	400061	Standoff, Slide Weight Short, Metric	4
2	400062	400062	Standoff, Slide Weight Long	2
3	6280-156L	6280-156L	Body, Main, Upper, Left	1
4	6280-156R	6280-156R	Body, Main, Upper, Right	1
5	6280-165	6280-165	Cleaner, Wheel	2
6	73204	73204	Washer, Lock, 3/8	4
7	73201	73201	Screw, Hex Head Cap, 3/8-16 x 1	4
8	73264	73264	Washer, Flat, Zinc USS 3/8	4
9	73311		Screw, Socket Head Cap, 5/16-18 x 1	4
		401848	Screw, Socket Head Cap, M8-1.25 x 25	
11	73303	73303	Washer, Split Lock 5/16	4
12	74763	74763	Grommet, Rubber 1/2"	1

IDLER MOUNT

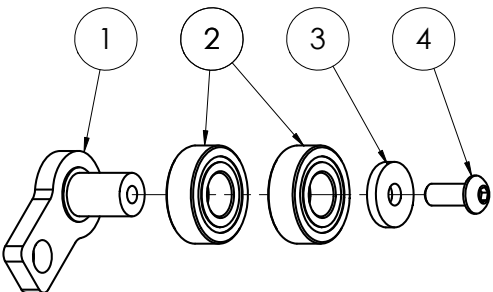

ITEM NO.	PART NUMBER	DESCRIPTION	QTY.
1	6280-125W	Bracket and Pin, Idler Mount	1
2	71072	Bearing, 1/2 ID DCTN-1616	2
3	6280-126A	Cap, Idler Bearing	1
4	73003	Screw, Button Head Socket Cap 1/4-20x5/8	1

Parts List and Diagrams

WEIGHTS

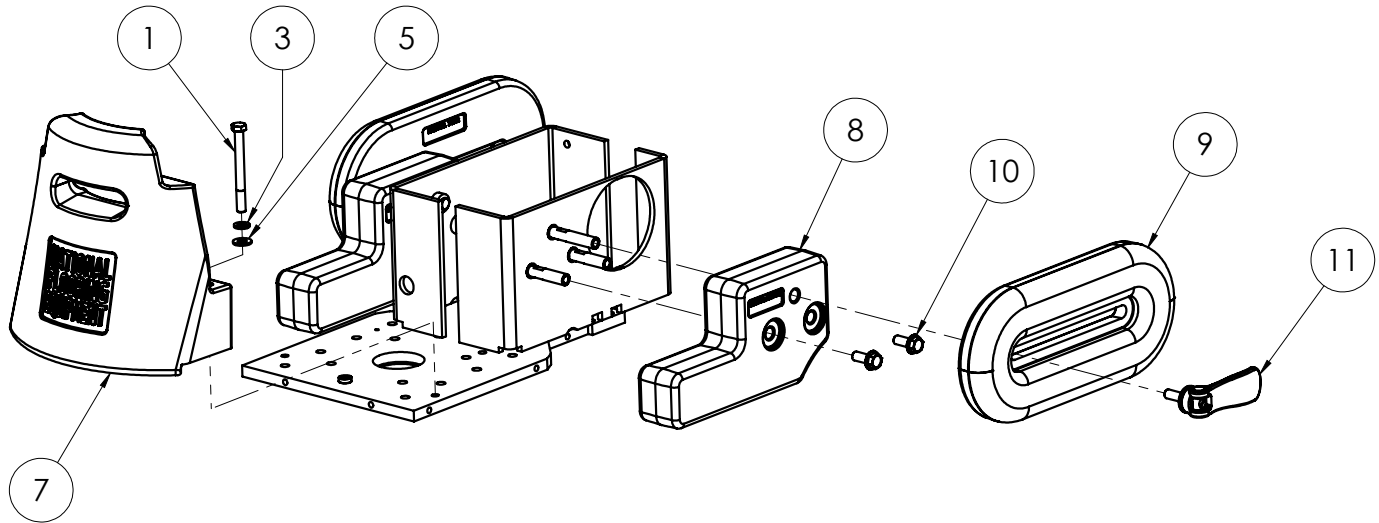

ITEM NO.	6280-10XXXX 6280-23XXXX	6280-12XXXX	6280-11XXXX 6280-13XXXX 6280-20XXXX 6280-26XXXX 6280-28XXXX	6280-15XXXX	DESCRIPTION	QTY.
1	400269	400269			Bolt, Hex Head, 3/8-16 x 3-3/4	2
			400184	400184	Bolt, M10-1.5 x 90, HHCS	
3	73204	73204			Washer, Lock, 3/8	2
			74657	74657	Washer, Lock, M10	
5	73263	73263			Washer, Flat SAE Zinc 3/8	2
			74655	74655	Washer, Flat, M10	
7	74852-SV	74852-G	74852-SV	74852-O	Weight, Front, Green Weight, Front, Orange Weight, Front, Silver Vein	1
8	74853-BLK	74853-BLK	74853-BLK	74853-BLK	Side weight	2
9	74851-SV	74851-G	74851-SV	74851-O	Weight, Slide, Green Weight, Slide, Orange Weight, Slide, Silver Vein	2
10	74650	74650	74650	74650	Bolt, Hex Flange M10-25	4
11	400119	400119	400119	400119	Lever, Cam, M10	2

FRONT WHEEL ASSEMBLY

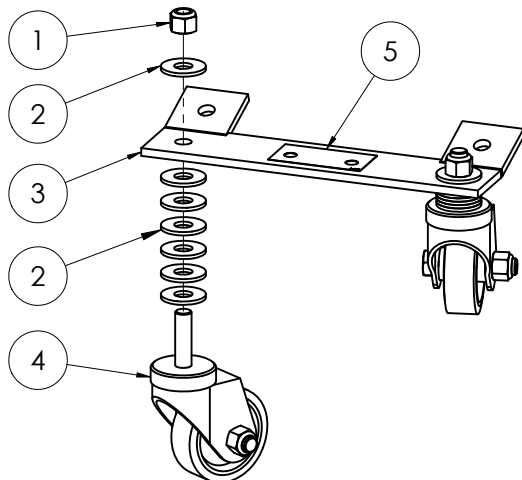

ITEM NO.	PART NUMBER	DESCRIPTION	QTY.
1	73402	Nut, Nylock 1/2-13	2
2	73425	Washer, Flat USS Zinc 1/2	14
3	6280-300	Bracket, Transport Wheel	1
4	6280-301	Caster Assy, Swivel, 3-inch, Stem	2
5	L191	Label Caution	1

Parts List and Diagrams

CUTTING HEAD

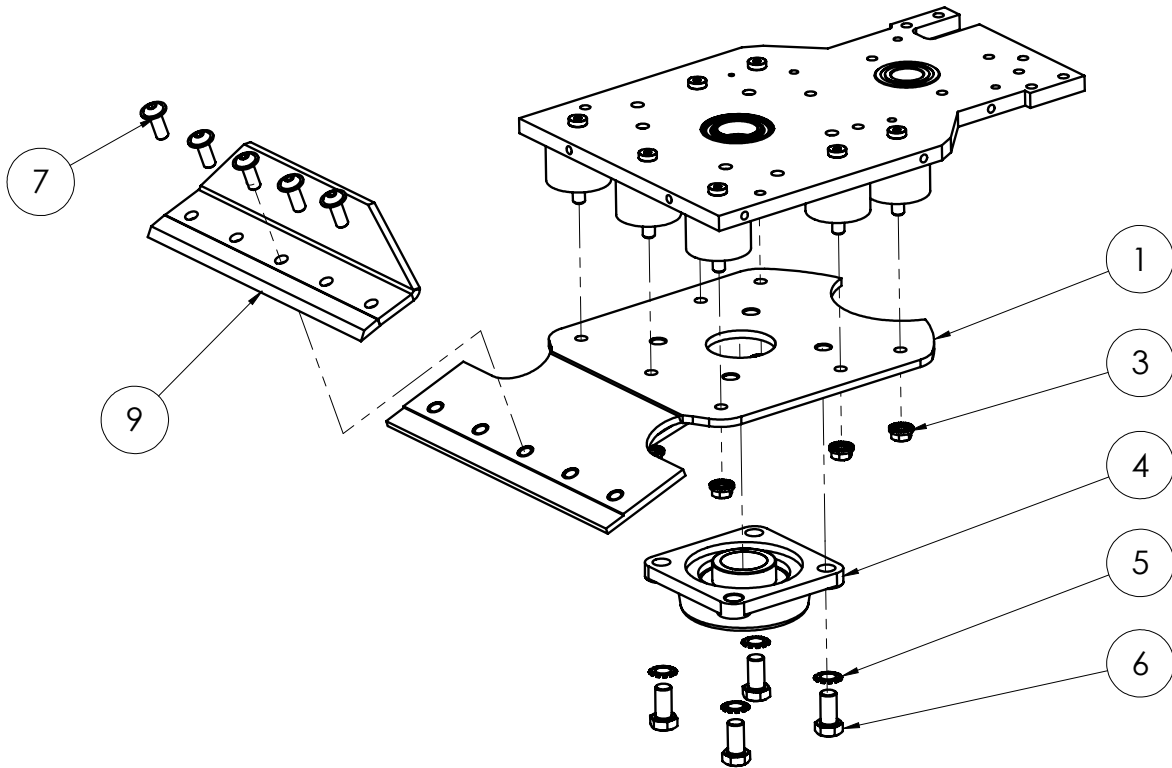

ITEM NO.	6280-10XXXX 6280-12XXXX 6280-23XXXX	6280-13XXXX 6280-15XXXX 6280-11XXXX 6280-20XXXX 6280-26XXXX 6280-28XXXX	DESCRIPTION	QTY.
1	6280-330		Head, Cutting, Heavy Duty	1
		401638	Head, Cutting, Metric	1
3	73211	73211	Nut, Flange, Serrated, 3/8-16	7
4	71141	71141	Bearing, 1-7/16" ID 16SC4FB Dodge Housing Assy	1
5	73423	73423	Washer, Interior/Exterior Lock 1/2"	4
6	73418	73418	Bolt, Hex Head 1/2-20x1	4
7	73242		Screw, Button Head Cap with Flange 3/8-16 x 1	5
		74649	Screw, Button Head Cap With Flange M10-25	5
9	6280-136	6280-136	Cover, Blade	1

Parts List and Diagrams

BOTTOM AND BACK COVER

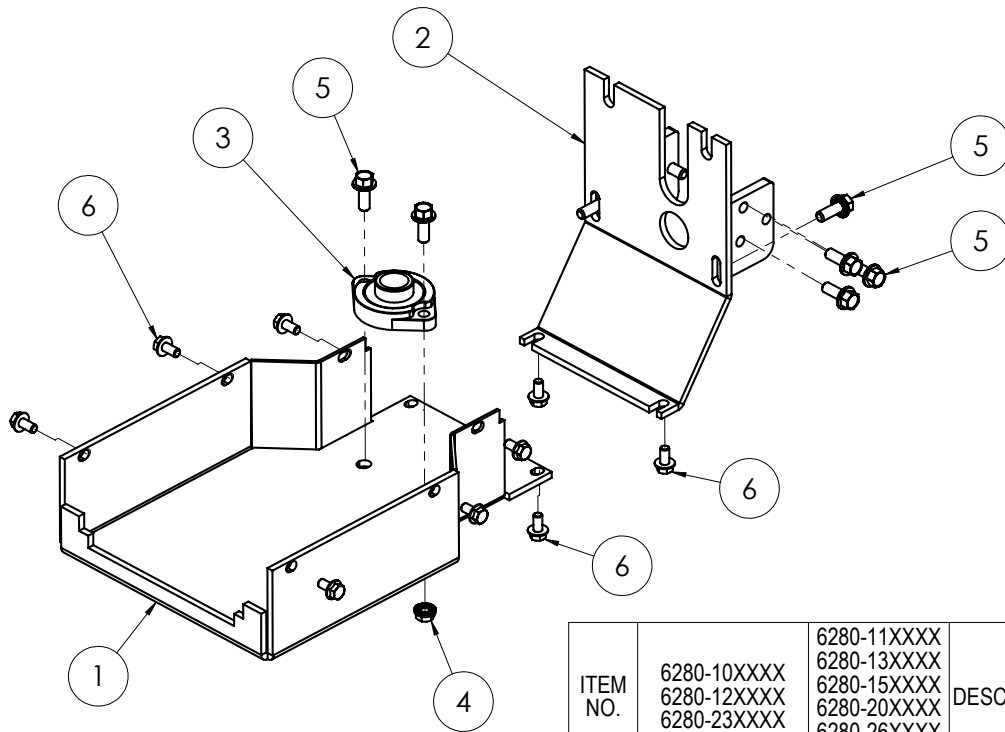

ITEM NO.	6280-10XXXX 6280-12XXXX 6280-23XXXX	6280-11XXXX 6280-13XXXX 6280-15XXXX 6280-20XXXX 6280-26XXXX 6280-28XXXX	DESCRIPTION	QTY.
1	6280-138	6280-138	Cover, Main Bottom	1
2	6280-139	6280-139	Cover, Rear	1
3	71118	71118	Bearing, Flange	1
4	73211	73211	Nut, Flange, Serrated, 3/8-16	2
5	73222	73222	Bolt, Flange 3/8-16 x 1	10
6	73318		Bolt, Wizlock Flange 5/16-18x5/8	10
		74631	Bolt, Hex Flange Bolt M6-16	

WHEELS

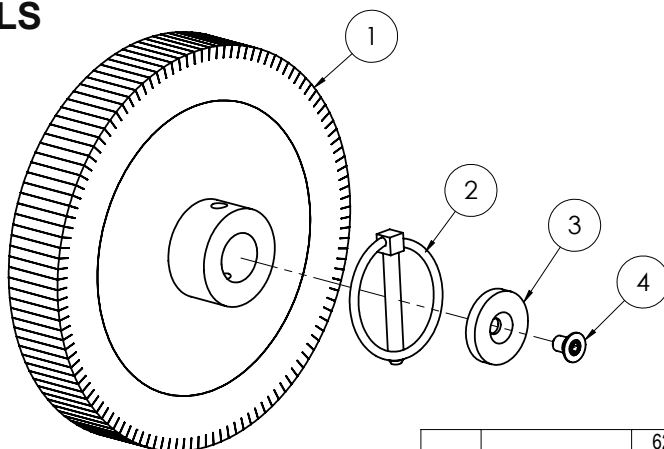

ITEM NO.	6280-10XXXX 6280-12XXXX 6280-23XXXX	6280-11XXXX 6280-13XXXX 6280-15XXXX 6280-20XXXX 6280-26XXXX 6280-28XXXX	DESCRIPTION	QTY.
1	402591	402591	Wheel, Drive, Siped, Med. Duty, 8.25 x 1.38	2
2	402311	402311	Pin, Lynch, 5/16 x 2-1/16	2
3	6280-112	6280-112	Cap, Wheel	2
4	73313		Screw, Flat Head Socket Cap 5/16-18x1/2	2
		400342	Bolt, Flat Socket Head, M8 1.25 x 14mm	

Parts List and Diagrams

ECENTRIC, CHAIN, AND BELT

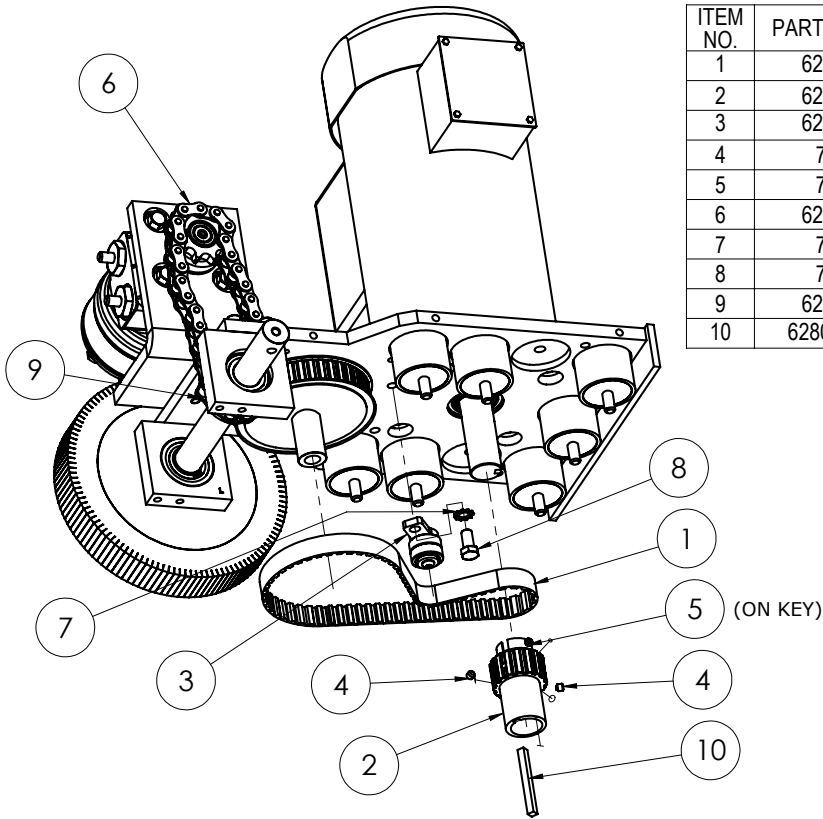

ITEM NO.	PART NUMBER	DESCRIPTION	QTY.
1	6280-124	Belt, Pump Drive, DD12	1
2	6280-405	Eccentric	1
3	6280-125	Assembly, Idler	1
4	73010	Screw, Set 1/4-20x1/4	2
5	73039	Screw, Set, 1/4-20x3/16	1
6	6280-228	Chain, Drive	1
7	73215	Washer, External Lock 3/8	1
8	73218	Bolt, HHCS, 3/8-24x.75	1
9	6280-229	Link, Master, Drive Chain	1
10	6280HD-131	Key, Eccentric	1

HYDRAULIC MOTOR

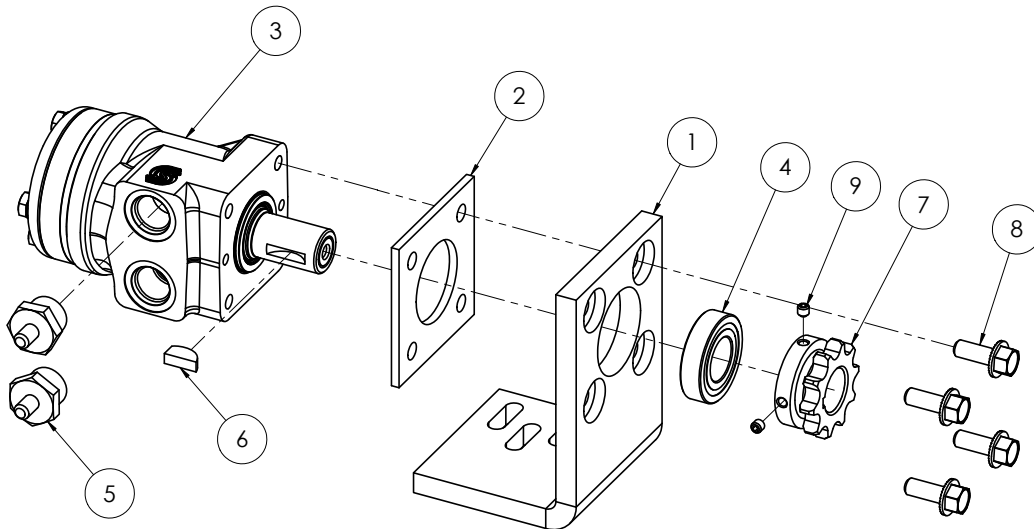

ITEM NO.	PART NUMBER	DESCRIPTION	QTY.
1	6280-226	Bolt, Hex Head Cap 5/16-18x5/8	1
2	6280-225	Spacer, Hydraulic Motor	1
3	6280-220A	Motor, Hydraulic	1
4	71115	Bearing, 1x2x1/2	1
5	6280-221	Connector, Hydraulic Motor	2
6	6280-223	Key, Shaft, Hydraulic Motor	1
7	401541	Sprocket, Axle, Heavy Duty	1
8	73222	Bolt, Flange 3/8-16 x 1	4
9	73010	Screw, Set 1/4-20x1/4	2

Parts List and Diagrams

BASE

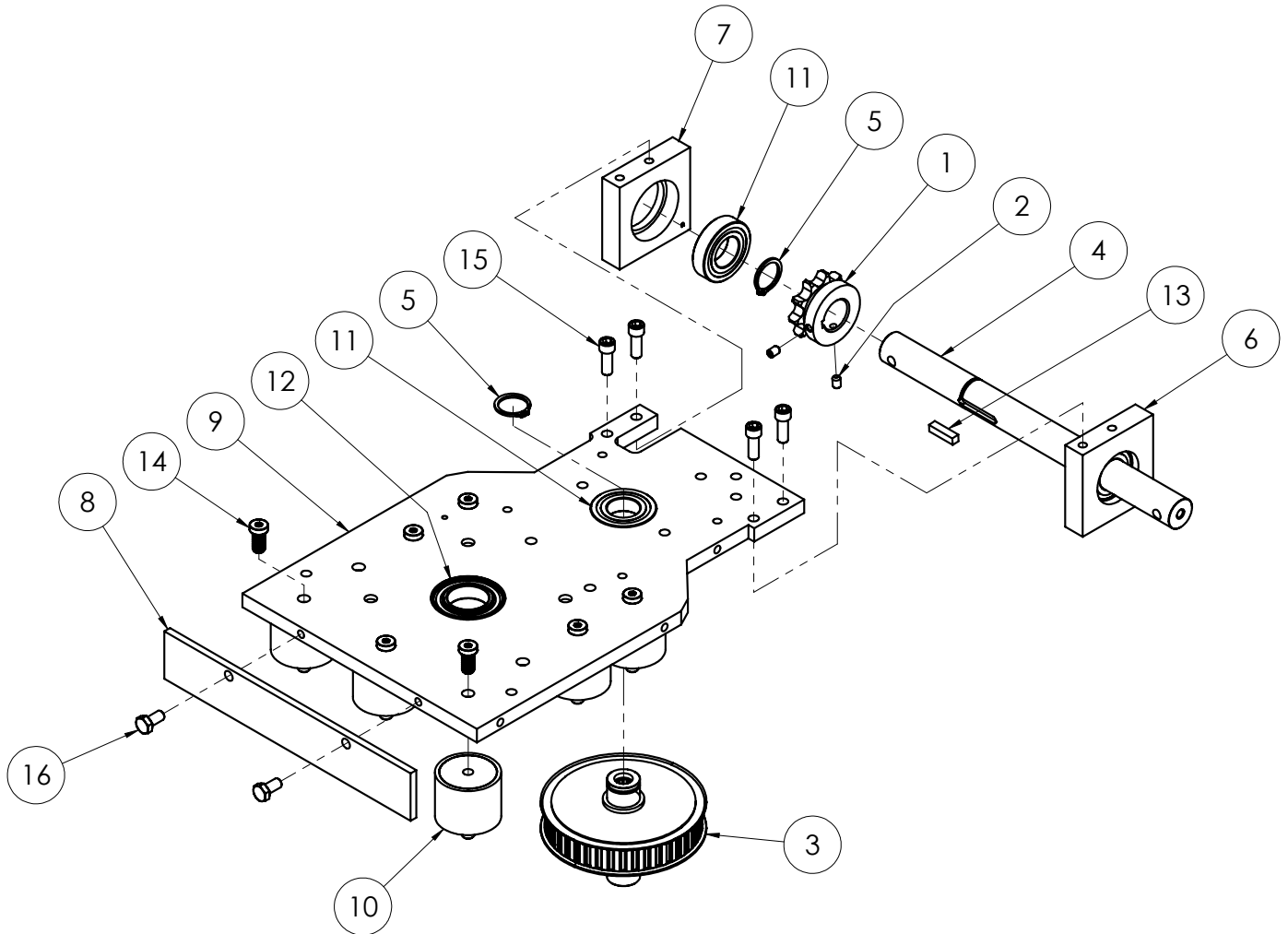

ITEM NO.	6280-10XXXX 6280-12XXXX 6280-23XXXX	6280-11XXXX 6280-13XXXX 6280-15XXXX 6280-20XXXX 6280-26XXXX	DESCRIPTION	QTY.
1	401541	401541	Sprocket, Axle, Heavy Duty	1
2	73012	73012	Screw, Set, 1/4-20 x 3/8	2
3	401627	401627	Pump Drive Assembly, Splined	1
4	6280-103-1	6280-103-1M	Shaft, Axle	1
5	6280-103A	6280-103A	Ring, Retaining, Ext, Axial, 1"	3
6	6280-105L	6280-105LM	Support, Axle Bearing, Left	1
7	6280-105R	6280-105RM	Support, Axle Bearing, Right	1
8	6280-145	6280-145	Cover, Front	1
9	6280HD-107	401526	Plate, Base, 6280HD	1
10	70810	70810	Isolator, Vibration	7
11	71115	71115	Bearing, 1x2x1/2	3
12	71132	71132	Bearing, 1-1/4	1
13	73033	73033	Key, 1/4x1/4x1	1
14	73217	73217	Screw, Socket Head Cap, Low, 3/8-16 x 3/4	7
15	73310	73310	Screw, Socket Head Cap, Grade 5 5/16-18x7/8	4
16	73332		Bolt, Hex Head Cap 5/16-18x5/8	2
		74631	Bolt, Hex Flange Bolt M6-16	2

Parts List and Diagrams

UPPER HANDLE ASSEMBLY

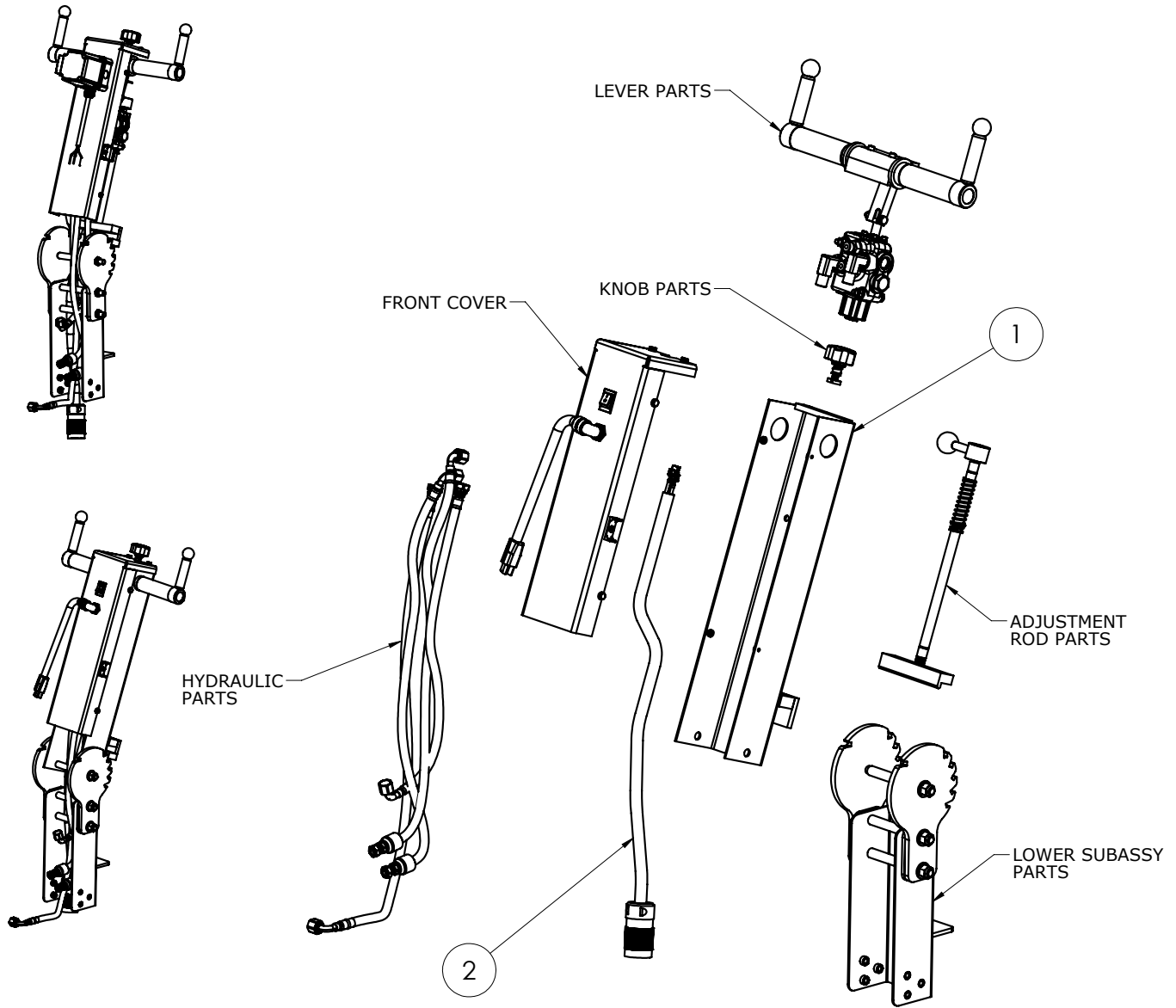

ITEM NO.	6280(HD)-10XXXX 6280(HD)-12XXXX 6280(HD)-23XXXX	6280(HD)-11XXXX 6280(HD)-13XXXX 6280(HD)-15XXXX 6280(HD)-20XXXX 6280(HD)-26XXXX 6280HD-27XXXX 6280(HD)-28XXXX	DESCRIPTION	QTY.
1	6280-601	6280-601	Weldment, Upper Handle	1
2	401588		Cord, Handle, Commander, 6280, 110V	1
		401589	Cord, Handle, Commander, 6280, 220V	

Parts List and Diagrams

HYDRAULIC HOSES

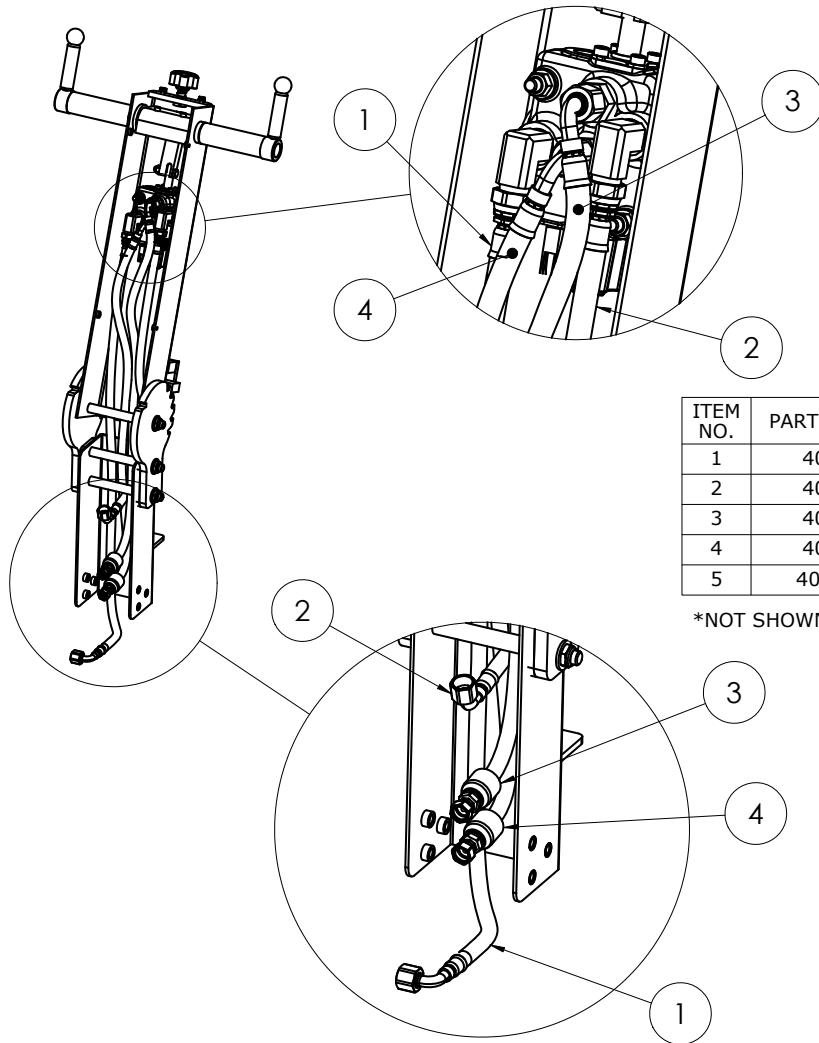

ITEM NO.	PART NUMBER	DESCRIPTION	QTY.
1	400031	Hose, Hydraulic, 1/4 x 40, F/90F	1
2	400033	Hose, Hydraulic, 3/8 x 36, F/F	1
3	400032	Hose, Hydraulic, 1/4 x 33, F/90F	1
4	400032	Hose, Hydraulic, 1/4 x 33, F/90F	1
5	400097*	Wrap, Kevlar	21"

*NOT SHOWN

LOWER SUB-ASSEMBLY

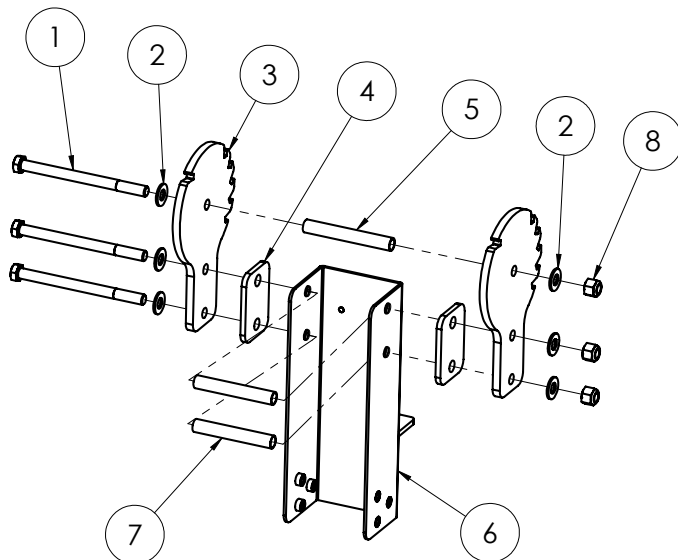

ITEM NO.	6280(HD)-10XXXX 6280(HD)-12XXXX 6280(HD)-23XXXX	6280(HD)-11XXXX 6280(HD)-13XXXX 6280(HD)-15XXXX 6280(HD)-20XXXX 6280(HD)-26XXXX 6280HD-27XXXX 6280(HD)-28XXXX	DESCRIPTION	QTY.
1	400056		Bolt, Hex Head 1/2-13x6-1/2	3
2	73424		Washer, Flat, Zinc SAE 1/2	6
3	6280-600	403816	PLATE, INDEX, HANDLE	2
4	400077		Gasket, Handle	2
5	6280-618		Tube, Spacer, Long	1
6	401629		Handle, Lower, Rack Pins	1
7	6280-619		Spacer Tube, Short	2
8	73402		Nut, Nylock 1/2-13	3

Parts List and Diagrams

LEVER AND WELDMENT

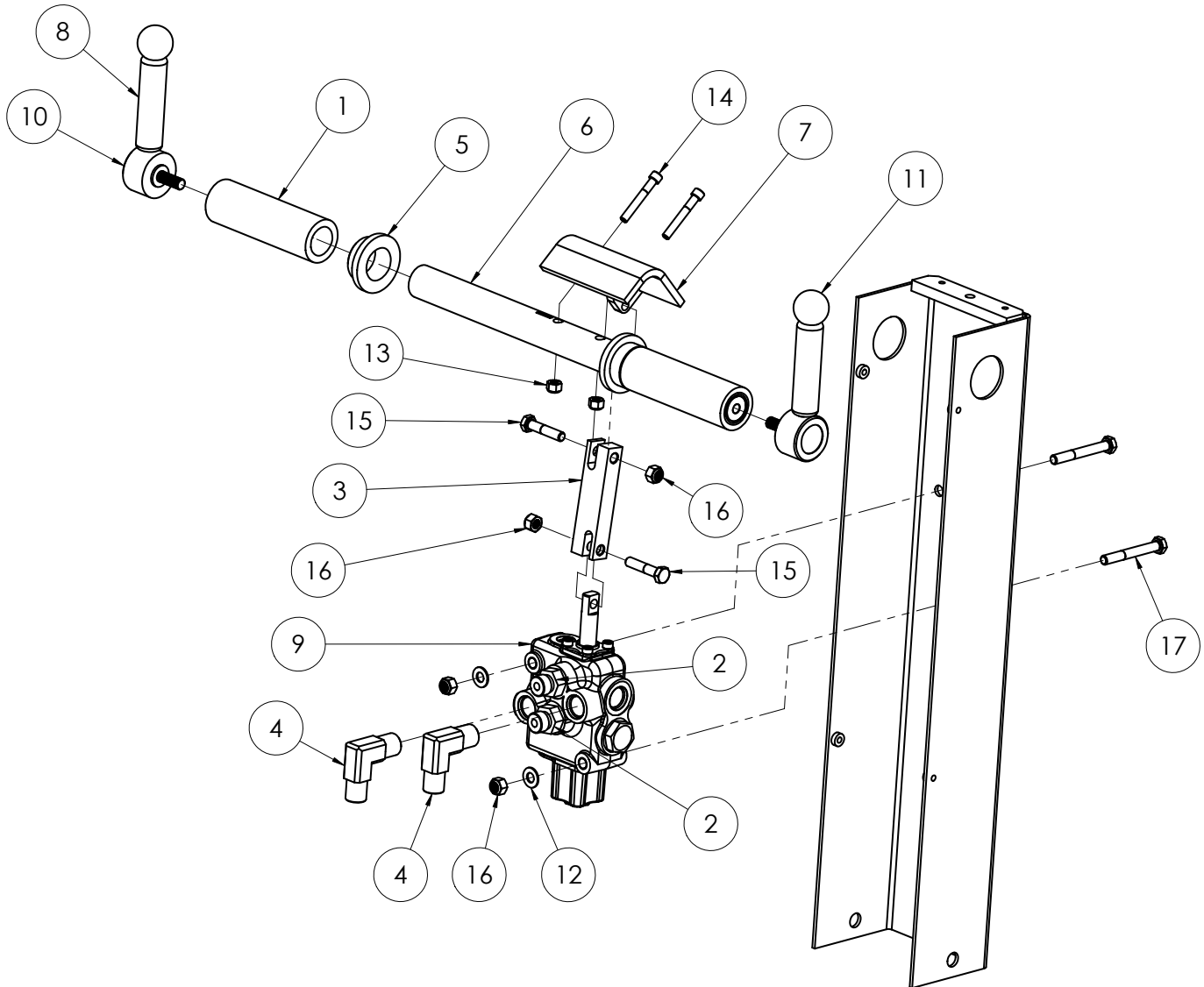

ITEM NO.	PART NUMBER	DESCRIPTION	QTY.
1	400024	Grip, Foam, 1"	2
2	400034	Fitting, FF1231-06-08	2
3	401434	Linkage, Valve, Handle	1
4	5280-118	Fitting, 90 Degree	2
5	6280-607	Bushing, Handle Bar	2
6	6280-608	Weldment, Handle Bar	1
7	6280-613	Bracket, Valve Connector	1
8	70623	Grip, Foam	2
9	70624	Valve, Single Spool, Tapered	1
10	70636	Lever, Adjustable, Right Hand	1
11	70637	Lever, Adjustable, Left Hand	1
12	73351	Washer, Flat, 5/16, SAE	2
13	73008	Nut, Nylock 1/4-20	2
14	73066	Bolt, SHCS, 1/4-20x1.75	2
15	73334	Bolt, Hex Head Cap 5/16-18x1-1/2	2
16	73322	Nut, Nyloc, 5/16-18	4
17	73327	Bolt, Hex Head Cap 5/16-18x2 1/2	2

Parts List and Diagrams

FRONT COVER

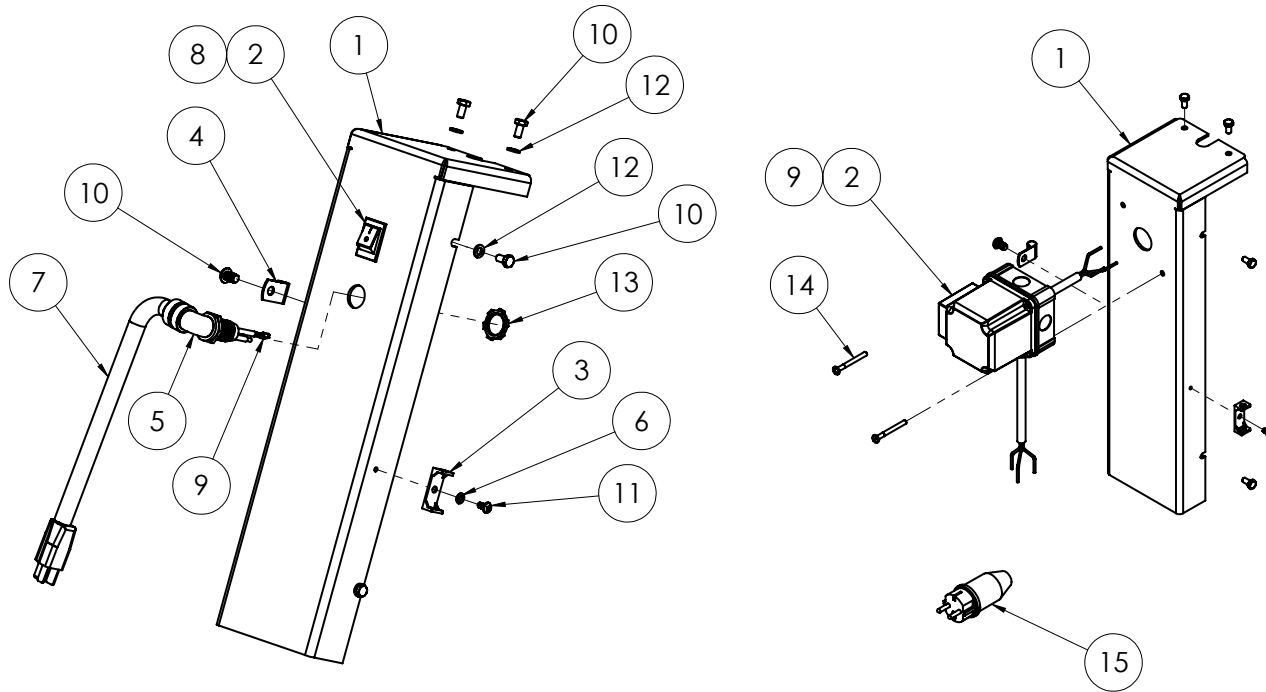

ITEM NO.	6280(HD)-10XXXX 6280(HD)-12XXXX 6280(HD)-23XXXX	6280(HD)-11XXXX 6280(HD)-15XXXX 6280(HD)-26XXXX	6280(HD)-13XXXX	6280(HD)-20XXXX	6280(HD)-27XXXX	6280(HD)-28XXXX	DESCRIPTION	QTY.
1	6280-602	403807	403807	403807	6280-602	403807	Cover, Upper Handle	1
2	6280-207	403776	403776	403814	6280-207	403815	Switch, On-Off	1
3	6280-404	6280-404	6280-404	6280-404	6280-404	6280-404	Holder, Blade Wrench	1
4	72873	72873	72873	72873	72873	72873	3/8 Cable Clamp	1
5	401682	N/A	N/A	N/A	401682	N/A	Connector, 1/2", 90 Degree	1
6	74413	74413	74413	74413	74413	74413	Washer, Internal Lock #10	1
7	6280-168	N/A	N/A	N/A	402839	N/A	Cord, Power, New Style Cord, Power, UK1-13P, BS1363A, Angle Plug, 13A 250 Volt	1
8	92819	92819	92819	92819	92819	92819	Disconnect, Quick, Nylon, 16-14 Gauge	2
9	72812	72812	72812	72812	72812	72812	Disconnect, 12-10 Gauge, Female, Nylon	1
10	73301	73301	73301	73301	73301	73301	Bolt, Button Head Socket Cap 5/16-18x1/2	1
11	74406	74406	74406	74406	74406	74406	Screw, Phillips Pan Head 10-32x3/8	1
12	74619	N/A	N/A	N/A	74619	N/A	Washer, Lock, M6	6
13	73401	N/A	N/A	N/A	73401	N/A	Nut, Strain Relief, Steel, 1/2"	1
14	N/A	403797	403797	403797	N/A	403797	Screw, Phillips Pan Head, M5-0.8 x 50mm	2
15	N/A	401438	72715	401486	N/A	403719	Power Cord Plug	1

Parts List and Diagrams

KNOB

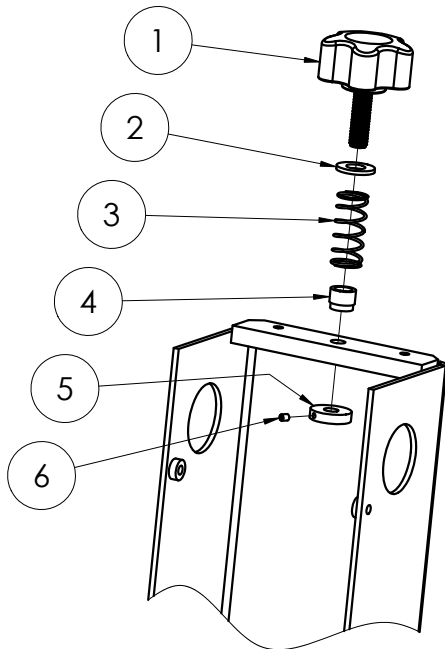

ITEM NO.	PART NUMBER	DESCRIPTION	QTY.
1	70638	Knob, Adjustable, 1-1/4"	1
2	73263	Washer, Flat SAE Zinc 3/8	1
3	402290	Spring, .66"OD x 1.50"L x .049"w	1
4	402256	Sleeve, Knob, Commander Handle	1
5	401997	Stopper, Speed Control	1
6	400340	Screw, 6-32 x 3/16 SSS CP	1

ADJUSTMENT ROD

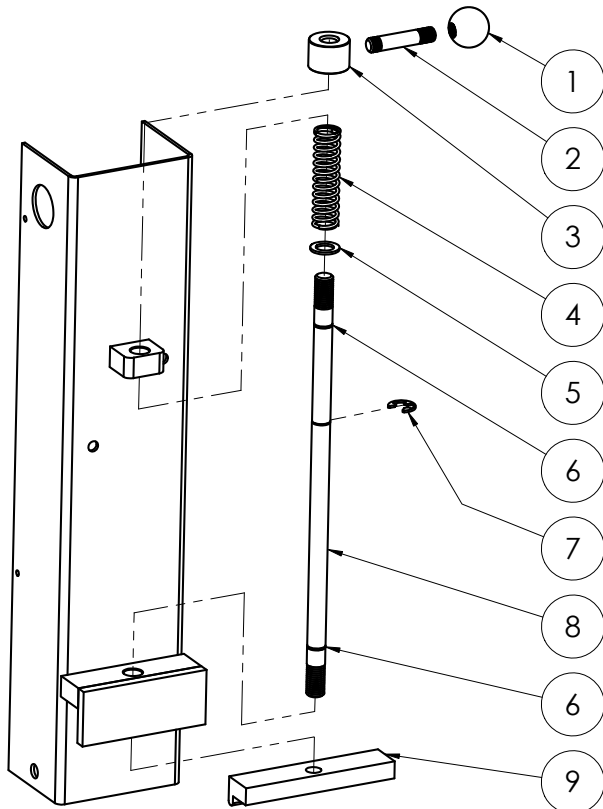

ITEM NO.	PART NUMBER	DESCRIPTION	QTY.
1	6280-606	Handle, Ball	1
2	92800-98	Rod, Adjustment, Short	1
3	92800-99	Collar, Adjustment Rod	1
4	92800-12	Spring, Adjustment, 3.5"	1
5	402201	Washer, .625 ID x 1.000 OD	1
6	402197	O-ring, .489 ID X .629 OD X .070 W	2
7	402200	E-Clip, Shaft, .625	1
8	402219	Rod, Adjustment, Large, 3X Groove	1
9	6280-611	Lock, Adjustment Bar	1

Parts List and Diagrams

115V WIRING

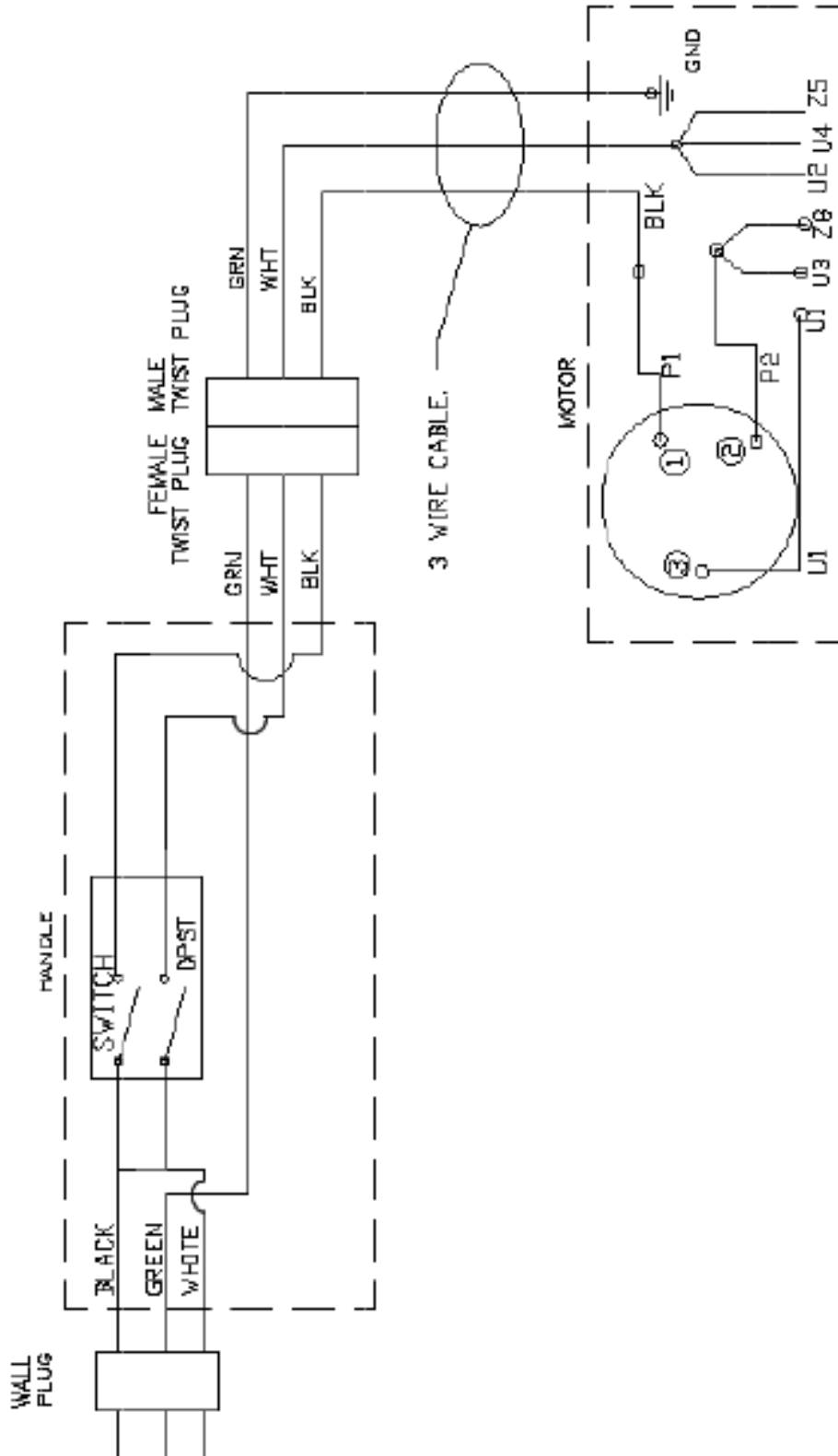

Parts List and Diagrams

HYDRAULICS

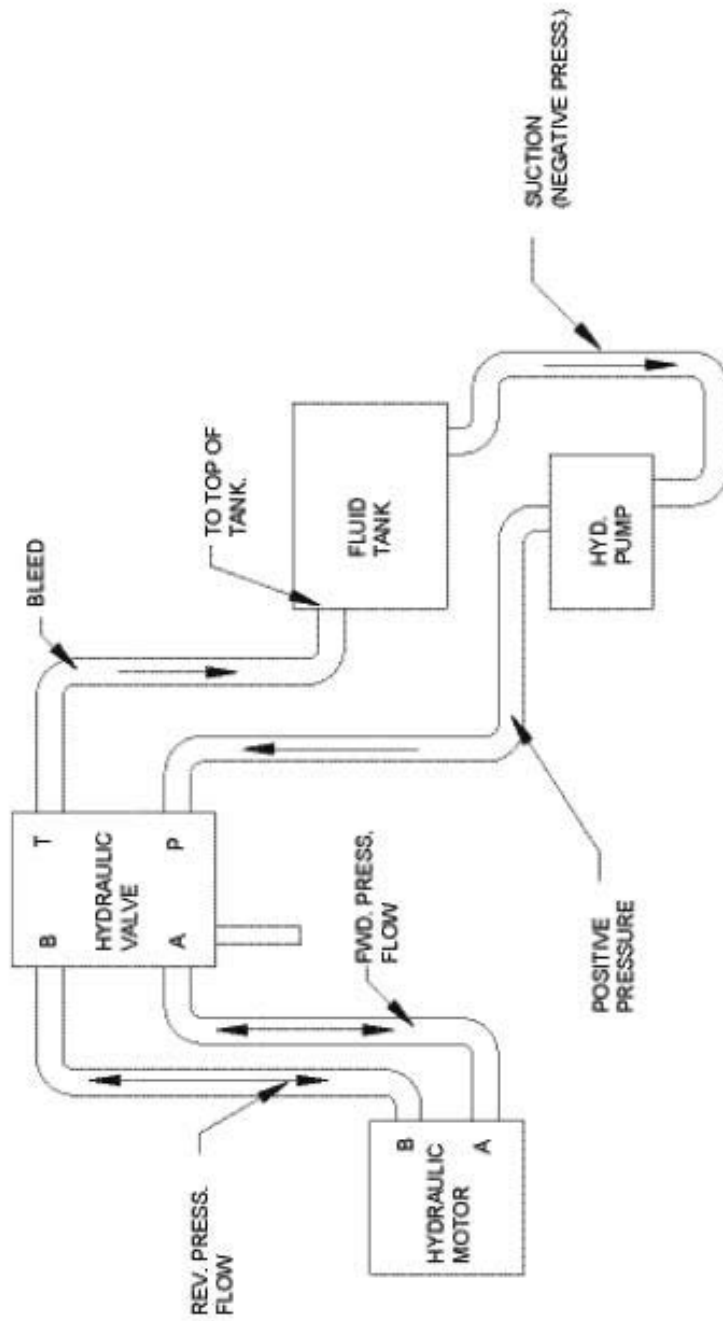

Warranty

National Flooring Equipment Inc. (referred to as "the Company") warrants that each new unit manufactured by The Company, to be free from defects in material and workmanship in normal use and service for a period of twelve (12) months from date of shipment from the Company. For administrative ease, will honor warranty for a period of fifteen (15) months from date of shipment from the company. Accessories or equipment furnished and installed on the product by the Company but manufactured by others, including but not limited to: engines, motors, electrical components, transmissions etc., shall carry the accessory manufacturers own warranty. Battery warranties are prorated over the warranty period. Customer is responsible for the inspection of equipment / parts upon delivery. Freight damages reported beyond authorized time frame will not be honored.

The Company, at its determination of defect, will repair or replace any product or part deemed to be defective in material or workmanship within specified warranty time period. All product determinations and / or repairs will take place at the designated Company repair facility, or at a certified warranty location designated by the Company. The Company will coordinate and be responsible for all freight expenses associated with valid warranty claims. Freight and shipping expenses associated with abuse or misuse will be back charged to the Distributor/Customer. The Company reserves the right to modify, alter or improve any part / parts without incurring any obligation to replace any part / parts previously sold without such modified, altered or improved part / parts. In no event shall the seller or manufacturer of the product be liable for special, incidental, or consequential damages, including loss of profits, whether or not caused by or resulting from the negligence of seller and / or the manufacturer of the product unless specifically provided herein. This warranty shall not apply to any products or portions there of which have been subjected to abuse, misuse, improper installation or operation, lack of recommended maintenance, electrical failure or abnormal conditions and to products which have been tampered with, altered, modified, repaired, reworked by anyone not approved or authorized by the Company or used in any manner inconsistent with the provisions of the above or any instructions or specifications provided with or for the product. Any and all unauthorized onsite warranty work conducted by unauthorized personnel or any outside person(s), is not covered by the Company unless the work has been pre-authorized by a predetermined manufacturer representative. This excludes wearable parts and/or consumables.

Defective or failed material or equipment shall be held at the purchaser's premises until authorization has been granted by the Company to return or dispose of defective products. Products returned for final inspection must be returned with a manufacturer authorized Return Material Authorization (RMA). Any unauthorized return of equipment will be declined at the dock by the Company. Any non-approved items returned with approved returned items are subject to rejection and will not be credited. Credit will be issued for material found to be defective upon the Company's inspection based on prices at time of purchase.

TO OBTAIN SERVICE CONTACT NATIONAL FLOORING EQUIPMENT, INC. TOLL FREE AT 800-245-0267 FOR A REPAIR AUTHORIZATION NUMBER. COD FREIGHT RETURNS WILL NOT BE ACCEPTED. FREIGHT COLLECT SHIPMENTS WILL NOT BE ACCEPTED. WARRANTY REPAIRS MUST BE ACCOMPANIED BY DATE OF PURCHASE RECEIPT AND A RETURN/ REPAIR AUTHORIZATION NUMBER.

RETURN/REPAIR AUTHORIZATION NUMBER: _____

MACHINE SERIAL NUMBER: _____



9250 Xylon Avenue N • Minneapolis, MN 55445 • U.S.A.
Toll-free 800-245-0267 • Phone 763-315-5300 • Fax 800-648-7124 • Fax 763-535-8255
Web Site: www.nationalequipment.com • E-Mail: info@nationalequipment.com