

# 2900

## HIGH SPEED RIDE-ON INSTRUCTION MANUAL



Caution: Read Manual Before Operating Machine



# Table of Contents

<b>Table of Contents</b> .....	<b>3-4</b>
<b>Features and Specifications</b> .....	<b>5</b>
<b>Safety</b> .....	<b>6-9</b>
General Rules for Safe Operation .....	6-7
Characteristics of a Defensive Operator .....	7
Hydraulic Safety Tips .....	7
Safety Switch .....	8
Battery Safety .....	8
Safety Precautions.....	9
<b>Battery/Charger Information</b> .....	<b>10-13</b>
Battery Operation.....	10
Installation.....	10
Cooling Time .....	10
Battery General Information.....	10
Machine Charging.....	11
Commonly Asked Battery Questions .....	12
Battery/Charger Troubleshooting.....	13
<b>Machine Operation</b> .....	<b>14-24</b>
Power On Switch .....	14
Machine Start-up Procedure.....	14
Hydraulic Levers .....	14
Emergency Stop Switch.....	15
Seat Switch.....	15
Cylinder Lift.....	15
Caster .....	16
Foot Peg .....	16
Seat .....	16
Raising or Lowering The Slide Plate.....	16
Loading/Unloading.....	17
Center of Gravity.....	17
Job Site Movement.....	18-19
Wheel Size.....	19
Cutting Head and Blades.....	20
Adjusting Slide Plate and Cutting Head.....	20
Blade Setting .....	21-23
Ditching .....	24
Blade Sharpening .....	24
<b>Blades</b> .....	<b>25-27</b>
<b>Machine Maintenance</b> .....	<b>28-32</b>
Slide Plate.....	28
Hydraulic Fluid .....	28-29
Hydraulic Cylinder Change Out .....	29
Engine Oil Change Out.....	29
Hose Change Out.....	29
Foot Peg Change Out.....	29
Pump Change Out.....	30
Valve Change Out.....	30
Wheel Changing .....	30
Changing Hydraulic Fluid Filter.....	31
Seat Replacement .....	31
Caster Maintenance.....	31
Debris Deflector Mounting Instructions.....	32
<b>Troubleshooting Guide</b> .....	<b>33</b>
<b>Complete Parts List</b> .....	<b>34-35</b>
<b>Parts Lists and Diagrams</b> .....	<b>36-53</b>
External Parts .....	36-37
Hood Lever Parts .....	37
Backup Beeper Assembly.....	38
Handle Switch (For Beeper) .....	38

# Table of Contents

---

Instruction Tube Parts .....	38
Electric Box & Battery Connector Parts .....	39
Motor Parts .....	40
Pump Parts .....	41
Wheel Motor Parts .....	42
Filter Parts .....	43
Control Lever Parts .....	44
Cylinder Parts .....	45
Cylinder Hose Guard Parts .....	45
Slide Plate Parts .....	46
Caster Parts .....	46
Foot Peg Parts .....	46
Weights .....	47
Batteries .....	47
Charger .....	47
Labels .....	48-49
Accessories .....	50
Control Box Wiring Diagram .....	51
Seat Wiring Diagram .....	52
Battery Wiring Diagram .....	53
<b>Material Safety Data Sheet .....</b>	<b>54-66</b>
<b>Guarantee .....</b>	<b>67</b>

# Features and Specifications

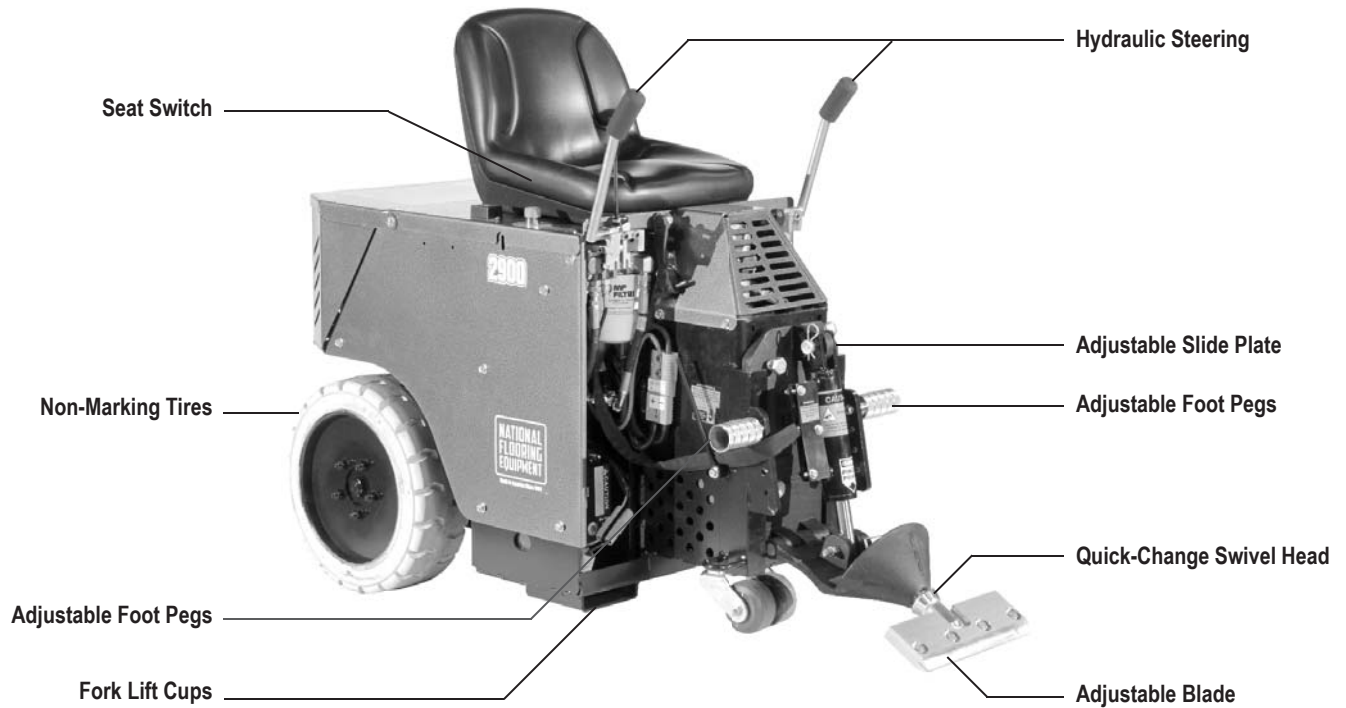

The 2900 High Speed Battery Ride-On is a durable, emission-free, budget conscious work horse specifically designed for high speed soft goods removal. The compact design enables the scraper to fit through standard door frames and most passenger and freight elevators.

## FEATURES

**Non-marking Tires** - Large non-marking tires, work on all types of application and debris build up.

**Seat Switch** - Seat switch and E-Stop knob for safety.

**Hydraulic Steering** - Forward, reverse, turn and brake with easy move control levers.

**Adjustable Slide Plate** - Affords maximum versatility in blade settings.

**Adjustable Foot Pegs** - Adjustable foot pegs provide optimal comfort and ergonomics.

**Quick-Change Swivel Head** - Assures continuous blade contact with the floor.

**Adjustable Blade** - Adjustable blade pitch and angle.

**Fork Lift Cups** - Easily accessible fork lift cups for easy loading and unloading.

## Product Specifications

Width	Length	Height	Weight	Fully Weighted	HP	Speed	Voltage
24.5" (62.2 cm)	52" (132.1 cm)	49.5" (125.7 cm)	1565 lb (709.9 kg)	1740 lb (789.3 kg)	4	Up to 160 ft. per minute	115

# Safety

---

## GENERAL RULES FOR SAFE OPERATION

**READ AND SAVE ALL INSTRUCTIONS FOR FUTURE USE.** Before use, ensure operators reads and understand this manual. Read and understand labeling on machine and components. All operators must view the instruction video. Extra copies of the manual and video are available by contacting National Flooring Equipment.

1. **KNOW YOUR EQUIPMENT:** Read this manual carefully to learn equipment applications and limitations, potential hazards associated with this type of equipment. Keep this manual with the equipment it is associated with.
2. **DISARM MACHINE:** Remove cutting head or drop cutting head to the floor when machine is not in use.
3. **DO NOT "SIDE HILL" MACHINE.**
4. **DISCONNECT CHARGER:** Disconnect machine from charger before operating machine.
5. **AVOID DANGEROUS ENVIRONMENTS:** Do not use in rain, damp or wet locations, or in the presence of explosive atmospheres (gaseous fumes, dust or flammable materials). Remove materials or debris that may be ignited by sparks.
6. **KEEP WORK AREA CLEAN AND WELL LIT:** Cluttered, dark work areas invite accidents.
7. **DRESS PROPERLY:** Do not wear loose clothing. These may be caught in moving parts. When working wear gloves and insulated non-skid footwear. Keep hands and gloves away from moving parts.
8. **USE SAFETY EQUIPMENT:** Proper eye protection should be worn at all times. Wear hearing protection during extended use and a dust mask for dusty operations. Hard hats, face shields, safety shoes, etc. should be worn when specified or necessary.
9. **KEEP BYSTANDERS AWAY:** Children and other bystanders should be kept at a safe distance from the work area to avoid distracting the operator and contacting the equipment or extension cord. Operator should be aware of the proximity of bystanders. This machine is not intended for use by persons (including children) with reduced physical, sensory or mental capabilities or lack of experience and knowledge.
10. **PROTECT OTHERS IN THE WORK AREA:** Provide barriers or shields as needed to protect others from debris.
11. **USE PROPER ACCESSORIES:** Using accessories that are not recommended may be hazardous. Be sure accessories are properly installed and maintained. Do not delete a guard or other safety device when installing an accessory or attachment.
12. **CHECK FOR DAMAGED PARTS:** Inspect guards and other parts before use. Check for misalignment, binding of moving parts, improper mounting, broken parts and other conditions that may affect operation. If abnormal noise or vibration occurs, turn off immediately and have the problem corrected before further use. Do not use damaged equipment. Tag damaged equipment "DO NOT USE" until repaired. Missing or damaged parts should be properly repaired or replaced immediately. For all repairs, use only identical National replacement parts.
13. **REMOVE ALL ADJUSTING KEYS AND WRENCHES:** Make a habit of checking that the adjusting keys, wrenches, etc. are removed from the tool before turning it on.
14. **GUARD AGAINST ELECTRIC SHOCK:** Prevent body contact with grounded objects such as pipes, radiators, ranges and any other related surfaces. When making cuts, always check the work area for hidden wires or pipes. Hold your equipment by insulated nonmetal grasping surfaces. Use a Ground Fault Circuit Interrupter (GFCI) to reduce shock hazards.
15. **AVOID ACCIDENTAL STARTING:** Be sure equipment is turned off before plugging in. Do not use equipment if the power switch does not turn the equipment on and off.
16. **DO NOT FORCE EQUIPMENT:** Equipment will perform best at the rate for which it was designed. Excessive force only causes operator fatigue, increased wear and reduced control.
17. **KEEP HANDS AWAY FROM ALL CUTTING EDGES AND MOVING PARTS.**
18. **WEAR** gloves when changing accessories.
19. **DO NOT ABUSE CORD:** Never unplug by pulling the cord from the outlet. Pull plug rather than cord to reduce the risk of damage. Keep the cord away from heat, oil, sharp objects, cutting edges and moving parts.
20. **DO NOT OVERREACH. MAINTAIN CONTROL:** Keep proper footing and balance at all times. Maintain a firm grip.
21. **STAY ALERT:** Watch what you are doing and use common sense. Do not use when you are tired, distracted or under the influence of drugs, alcohol or any medication causing decreased control.
22. **CHARGING MACHINE:** On/Off switch must be in off position before connecting to power source.
23. **UNPLUG EQUIPMENT:** When not in use and before changing accessories or performing recommended maintenance, unplug machine.
24. **MAINTAIN EQUIPMENT CAREFULLY:** Keep handles dry, clean and free from oil and grease. Keep cutting edges sharp and clean. Follow instructions for lubricating and changing accessories. Inspect equipment cords and extension cords for damage. Replace damaged parts. Use only identical National replacement parts.

25. **STORE IDLE EQUIPMENT:** When not in use, store in a dry, secured place. Keep away from children.
26. **MAINTAIN LABELS AND NAMEPLATES:** These carry important information. If unreadable or missing, contact National for a replacement.
27. **MACHINE IS HEAVY, DO NOT DROP.** Ensure proper lifting procedures are followed when transporting.
28. **DO NOT USE ON STEPS.**
29. **DO NOT ALLOW** the cutting heads to come into contact with the supply cord.
30. **BATTERIES:** Periodically inspect batteries, charger and all plug connections. Only the manufacturer or an authorized servicing agent should replace the batteries. Do not open or tamper with batteries. Doing so voids all warranties and could cause injury due to electrical shock.
31. **REGULARLY EXAMINE** the supply cord for damage, such as cracking or aging. If damaged, replace the cord before further use. Only replace the supply cord with the type specified in this manual.

## CHARACTERISTICS OF A DEFENSIVE OPERATOR

A Good Operator is a “Defensive” Operator!

### QUALITIES INCLUDE:

**Education:** Acquires knowledge of the machine, jobsite condition and the surrounding environment.

**Alert:** Stays alert at all times and never lets guard down.

**Skills:** Only performs duties they are qualified to do. Continually tries to improve.

**Judgment:** Use sound judgement and does not take careless chances.

**Common Sense:** Applies knowledge in practical situations.

**Recognizes the Hazards:** Maintains alertness and anticipates danger.

**Understands the Defense:** Knows that safety isn't an accident. A person must choose to follow a forward-thinking mind set.

**Acts Correctly:** Does not give in to peer pressure. Performs correctly when supervised or not.

## HYDRAULIC SAFETY TIPS

### MAINTAINING A SAFE WORK ENVIRONMENT

Establishing a safe work environment around your hydraulic equipment is paramount to safe and effective machine operation. The easiest and most effective way to avoid problems is to make sure coworkers understand equipment, know how to operate safely and recognize the danger represented if handled carelessly. A few things to be aware of:

1. **Pressure:** Hydraulic fluid under pressure is dangerous and can cause serious injury.
2. **Flammability:** When ignited, some hydraulic fluids can explode and/or cause fires.
3. **Mechanical:** Hydraulic fluid creates movement, which causes parts of your equipment to move or rotate. Always be aware of what you are doing.
4. **Moisture:** Use caution when operating in wet or high moisture conditions. Make sure all electrical fittings, switches, cords plus strain reliefs are in good condition. Always unplug when not in use and when doing any service work.
5. **Electrical:** Faulty wiring can also be an electrical hazard. A regular preventive maintenance program should always include a wiring check. Unplug batteries and/or charger before servicing.
6. **Temperature:** Because this machine operates at a relatively low pressure, overheating is not common. If surface of tank becomes too hot to touch by hand (above 130° F, 55°C), shut off machine and allow to cool off.

## PRESSURE

Our system runs at or below 3,000 psi. Never look for a leak when unit is under pressure. Using your hand could cause serious injury. A few common ways to encounter hydraulic fluid under pressure include:

1. **Pinhole:** Fluid under pressure can cause serious injury. It can be almost invisible escaping from a pinhole and it can pierce the skin into the body. Do not touch a pressurized hydraulic hose assembly with any part of your body. If fluid punctures the skin, even if no pain is felt, a serious emergency exists. Obtain medical assistance immediately. Failure to do so can result in loss of the injured part or death.
2. **Leak:** Keep fittings and hoses tight. Only check and service when not under pressure. Leaking hydraulic fluid is not only unsightly, it's hazardous. In addition to making workplace floors slippery and dangerous, leaks also contaminate the environment. Before cleaning an oil spill, always check EPA, state and local regulations.

# Safety

3. **Burst:** Whether due to improper selection or damage, a ruptured hose can cause injury. If it bursts, a worker can be burned, cut, injected or may slip and fall.
4. **Coupling Blow-off:** If the assembly is not properly made or installed, the coupling could come off and hit or spray a worker, possibly resulting in serious injury. Never operate machine without guards.



**CAUTION:** NEVER USE YOUR HANDS TO CHECK FOR LEAKS OVER HOSE OR HYDRAULIC CONNECTIONS. USE A PIECE OF CARDBOARD TO LOCATE A PRESSURIZED LEAK. FOR LOW PRESSURE LEAKS (DRIPS), USE A RAG TO CLEAN THE AREA AND DETERMINE WHERE THE LEAK ORIGINATES.

## FLAMMABILITY

With the exception of those comprised primarily of water, all hydraulic fluid is flammable when exposed to the proper conditions (including many "fire-resistant" hydraulic fluids).

Leaking pressurized hydraulic fluids may develop a mist or fine spray that can flash or explode upon contact with a cause of ignition. These explosions can be very severe and could result in serious injury or death.

Precautions should be taken to eliminate all ignition sources from making contact with escaping fluids, sprays or mists resulting from hydraulic failures. Sources of ignition could be electrical discharges (sparks), open flames, extremely high temperatures, sparks caused by metal-to-metal contact, etc.

## HYDRAULIC FLUID

Only use Texaco Rando 46 Hydraulic Oil or Compatible Fluid like IS032. Non-compatible fluids could cause damage to unit or serious injury.

## SAFETY SWITCH

The 2900 High Speed Battery Ride-On has been equipped with a safety switch under the seat, which requires the operator to be seated before the 2900 can be operated. Do not attempt the start-up procedure with out being seated on the machine.

## BATTERY

- Contact with electrolytic acid can cause skin irritation and damage clothing. Wear a protective apron, gloves and goggles when working with batteries. Have plenty of fresh water and soap nearby in case battery acid contacts your skin, clothing, or eyes.
- Remove personal metal items such as bracelets, rings, necklaces, and watches when working with batteries. A battery can produce a short circuit current sufficient enough to weld metal objects, causing severe burns.
- Never smoke or allow a spark or flame in the vicinity of the batteries. Caution must be taken to reduce the risk of dropping metal tools onto the battery. A spark or short circuit may result in an explosion.

## FIRST AID

Immediately flush eyes with cold, fresh water for a minimum of 10 minutes if electrolytic acid comes in contact with eyes. Seek professional medical attention.

## VENTILATION

Blocking louvers or air flow perforations of convection or fan cooled battery chargers and/or machine will result in damage to the unit. When installing the unit leave space for air to flow freely through the intake and discharge louvers and/or perforations.



**WARNING: SILICA DUST WARNING** SCRAPING/GRINDING/CUTTING/DRILLING OF MASONRY, CONCRETE, METAL AND OTHER MATERIALS CAN GENERATE DUST, MISTS AND FUMES CONTAINING CHEMICALS KNOWN TO CAUSE SERIOUS FATAL INJURY OR ILLNESS, SUCH AS RESPIRATORY DISEASE, CANCER, BIRTH DEFECTS OR OTHER REPRODUCTIVE HARM. IF YOU ARE FAMILIAR WITH THE RISKS ASSOCIATED WITH THE PARTICULAR MATERIAL BEING CUT, REVIEW THE MATERIAL SAFETY DATA SHEET AND/OR CONSULT YOU EMPLOYER, THE MATERIAL MANUFACTURER/SUPPLIER, GOVERNMENTAL AGENCIES SUCH AS OSHA AND NIOSH AND OTHER AUTHORITIES ON HAZARDOUS MATERIALS. CALIFORNIA AND SOME OTHER AUTHORITIES, FOR INSTANCE, HAVE PUBLISHED LISTS OF SUBSTANCES KNOWN TO CAUSE CANCER, REPRODUCTIVE TOXICITY, OR OTHER HARMFUL EFFECTS. CONTROL DUST, MIST AND FUMES AT THE SOURCE WHERE POSSIBLE. IN THIS REGARD USE GOOD WORK PRACTICES AND FOLLOW THE RECOMMENDATIONS OF THE MANUFACTURER/SUPPLIER, OSHA/NIOSH, AND OCCUPATIONAL AND TRADE ASSOCIATIONS. WHEN THE HAZARDS FROM INHALATION OF DUST, MISTS AND FUMES CANNOT BE ELIMINATED, THE OPERATOR AND ANY BYSTANDERS SHOULD ALWAYS WEAR A RESPIRATOR APPROVED BY OSHA/MSHA FOR THE MATERIAL BEING CUT.





## **GROUNDING AND A/C POWER CONNECTION INSTRUCTIONS**

The charger is equipped with an electrical cord with a equipment grounding conductor and grounding plug. The plug must be attached into an outlet that is properly installed and grounded in accordance with all local codes and ordinances.

## **SAFETY PRECAUTIONS (OPERATOR/PERSONNEL TRAINING)**

Operating and maintenance personnel must verify availability of appropriate fire protection equipment, be properly trained in the use of the equipment and know how to contact the Fire Department or Emergency Medical Service if needed.

## **SAFETY PRECAUTIONS**

- Only qualified, trained personnel should operate this unit.
- Loose or damaged parts should be replaced immediately. Failure to do so could cause equipment damage or serious injury.
- Switches and levers should be inspected. (Disconnect battery charger from wall outlet and machine from batteries before repairs to prevent electrical shock). Do not use if defective. Power on/off switch should return to off when lever is released.
- Power control box, motor and switches should be completely enclosed at all times with no exposed wiring.
- Disconnect negative lead before servicing. Failure to do so can cause damage to electrical system and/or electrical shock.
- Only use National components. Failure to do so could cause damage or serious injury.
- Always be aware of support personnel and their proximity when in operation. Block off work area.
- Support personnel should never stand next to machine, in front of or behind machine while machine is running. Failure to do so could cause serious bodily injury or death.
- Manual should be kept with machine in supplied holder for access by operator at all times.
- Always wear eye protection when running machine.
- Never defeat switches or guards.
- Remove blade when machine is not in use and/or lower cutting head to floor. Failure to do so could cause serious bodily injury.
- Wear gloves when changing blades. Always shut machine off when changing blades.

## **BEFORE CARRYING OUT MAINTENANCE OR REPAIR WORK:**

- Remove all traces of oil, combustible fuel or cleaning fluids from the scraper, its connections and fittings in particular.
- Do not use any aggressive cleaning products.
- Be sure that all cleaning rags are fiber free.
- Retighten all loose fittings found during maintenance and repair work.

# Battery/Charger Information

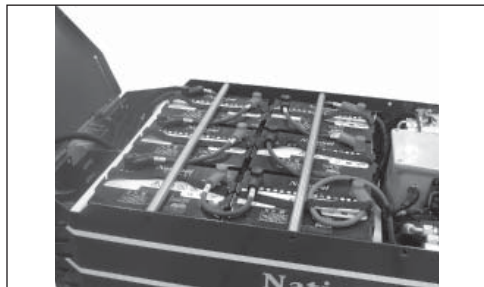

FIG. A

## BATTERY OPERATION

**Batteries do not take a memory allowing recharge at any state.**

Do not over discharge. Over discharging could cause damage to batteries.

### REMOVING BATTERIES

- Remove back lid
- Remove seat plate
- Disconnect back-up alarm
- Disconnect all wiring
- Remove batteries

### REPLACING BATTERIES

- Reverse procedure from above. Replace all six batteries at the same time.
- Store in a safe dry place.

SEE BATTERY MATERIAL SAFETY DATA INFORMATION ON PAGES 65-66

## INSTALLATION

1. To provide maximum reliability, charger must be installed in a well-ventilated area, so that free airflow is not restricted through the side intake and exhaust vents.
2. Check polarity of battery posts. Positive (POS, P, +) and Negative (NEG, N, -). Attach positive (red) charger lead to the positive battery post. Attach negative (black) charger lead to the negative battery post.



**WARNING:** DO NOT DISCONNECT DC CHARGER LEADS DURING CHARGING. DAMAGE TO THE CHARGER COULD RESULT AND VOID THE WARRANTY.



**WARNING:** DO NOT CONNECT DC CHARGER LEADS IF THE CHARGER IS CONNECTED TO AC POWER. DC CHARGER LEADS MUST BE CONNECTED FIRST.

## COOLING TIME

Although it is not necessary, but if the batteries are allowed to cool back to room temperature after being charged, you will get more life out of the batteries and charge cycle.

## BATTERY GENERAL INFORMATION

Batteries are designed to withstand high continuous shock load. They can be safely laid on the side, although keeping them upright at all time is suggested. Batteries are heavy, each battery is 86 lb (39 kg). Get help to remove batteries if weight is too much or you are under lifting restrictions. **Do not drop.**

When batteries have used their full life, they are recyclable at locations all over the US and Europe. Call National for recycle center. Batteries should only be maintained by certified National Technician.

Batteries are lead acid constructions. If packs are allowed to reach temperatures above 125° F (51.6°C), ventilation can occur and discharge explosive gases (see warning label). How is this done wrong? Improper charger's or improper connections, allowing for direct short.

# Battery/Charger Information

## MACHINE CHARGING

Machine has an on board charger (Figure B).

1. To eliminate accidental machine start-up while charging depress E-Stop Button (Figure C) before connecting to power source.
2. Connect to power source using a 7½ foot (2.25 m) 12-gauge extension cord.  
**NOTE:** Not using the proper gauge & length extension cord could cause improper charging and/or charger damage.

**Note:** Green light indicates battery at full charge, Yellow light indicates battery is 80% or above and Red light indicates below 80% charge.

3. Complete charging sequence.
4. Disconnect cord from the power source. Make sure the cord/plug is completely secured to the machine. Cord can fall under machine which causing damage to cord and/or plug.
5. Release E-Stop.

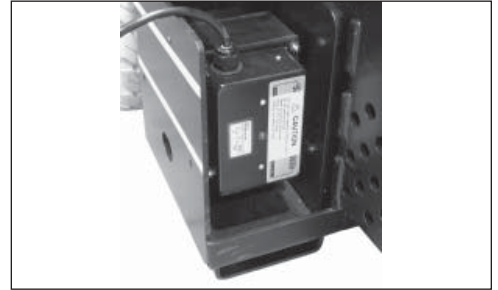

FIG. B



FIG. C



**WARNING:** ALWAYS FIND A SAFE PLACE FOR RECHARGING POWER PACKS WITH GOOD VENTILATION AWAY FROM SPARKS OR FLAME SOURCES AND AWAY FROM BYSTANDERS. ROPE OFF IF NECESSARY.



**WARNING:** ELECTRICAL SHOCK HAZARD. ONLY USE NATIONAL'S APPROVED CHARGING SYSTEM.



**WARNING:** DISCONNECT FROM POWER SOURCE BEFORE OPERATING. FAILURE TO DO SO COULD CAUSE DAMAGE TO MACHINE OR BODILY INJURY.

# Battery/Charger Information

---

## COMMONLY ASKED QUESTIONS

1. **Question:** When the charging battery has not been fully discharged will it take a memory set?

**Answer:** No, the design of these batteries allow charging at any stage of discharge without memory problems.

2. **Question:** Do I lose a complete cycle when I charge batteries that are only partially discharged?

**Answer:** No when 70% or higher useable charge is left. If below 70%, cycle will be used.

3. **Question:** Does the battery slow down as it discharges?

**Answer:** No, this design will give full power to 90% of the battery cycle. There will be an audible alarm alerting the operator to plug the scraper's charger into a suitable power source before a slowdown occurs.

4. **Question:** Can the battery spill?

**Answer:** No, unlike other batteries there is no liquid to spill out which allows for high shock load applications.

5. **Question:** Will batteries go dead during storage?

**Answer:** No, the battery design will hold up to 90% of it's charge up to 2 years without being used or charged.

6. **Question:** Does severe cold effect the batteries?

**Answer:** If fully charged, no. If allowed to warm up (room temperature) battery will perform better. If battery is under 75% charge, severe cold will destroy the battery.

7. **Question:** Do I have to let batteries cool down after charge?

**Answer:** No, but if you do, you will get more life out of the battery.

8. **Question:** Can the battery overheat and discharge gases?

**Answer:** Yes, if improper charger is used or the battery heats to over 50°C (125° F), gases off the vents inside of the batteries is possible. Caution must always be taken when charging batteries. Charge in a good ventilated area, away from sparks and open flame and away from bystanders.

9. **Question:** Can I leave the charger on too long?

**Answer:** No, the charging system is designed to read batteries state of charge constantly if left on for long periods of time (over the week-end) it will not hurt batteries or cause over charging problem.

10. **Question:** Can I leave the charger running while I am running the machine?

**Answer:** No, the charger must be unplugged from power supply before using.

# Battery/Charger Information

Problem	Cause	Solution
When plugged into AC power LED flashes red/green.	Connected reverse to battery, or not connected to battery.	Correct polarity, or connect to battery.
	Break in DC cord, or connector.	Have a qualified person make repair.
	Battery too dead to charge.	Replace.
When plugged into AC power LED does not come on.	No AC power.	Check circuit.
		Check extension cord for breaks or damage.
When I put a volt meter across the output of charger there is no power coming out when I plug it in.	Charger must be connected to a battery to turn on.	Connect charger to battery.
Batteries don't receive a full charge.	Charger is too small for the battery.	Check that charger's output is about 10% of the amp hour rating of the battery.
	Charge profile is not set correctly.	Recheck the dip switch setting. If in doubt, contact National.
	Cycle needs more time.	Use only a 7' (3 m) properly gauged extension cord when charging.
	Battery is defective.	Replace.
When switched on, LED flashes red/yellow.	Charger and battery voltage mismatch.	Connect charger to a battery(s) with the same voltage rating.
When powered up LED is solid red with a yellow flash.	Battery is very low, and charger is in a slow charge phase until the voltage rises to a safe level before full turn on.	Leave connected, it may take hours, but if the voltage rises even a little bit, it should recover and turn the charger full on. (Do not allow your batteries to deep discharge, it is the number one cause of premature battery failure.)
Charger blows it's fuse, or branch circuit fuse/circuit breaker as soon as it's switched on.	Charger is shorted.	Contact National or an authorized distributor's service facility.
Charger blows the branch circuit fuse/circuit breaker a short while after being switched on.	Branch circuit is too small.	Relocate charger to a branch circuit with a heavier rating, or remove other loads on the circuit.
After a full charge, the batteries die quickly.	Batteries are sulfated.	Sometimes batteries can be recovered. Leave charger on for some hours, if voltage falls and current begins to rise, it is a good sign they can recover under normal charging.
All other issues.		Please call National or an authorized distributor's service facility.

# Machine Operation

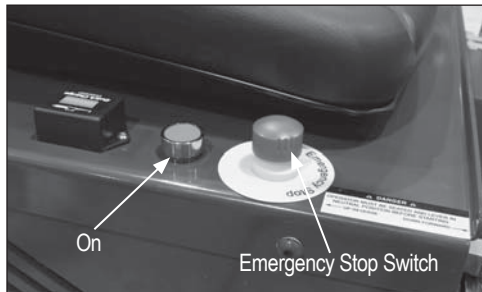

FIG. D

## POWER ON SWITCH (FIGURE D)

Never use the power On/Off switch as a method for speed control. Speed control is achieved by the hydraulic valve only. Using the On/Off switch repeatedly will cause excessive wear, causing premature replacement of electrical components. An Emergency Stop Switch (E-Stop) is located by right hand (Figure D). To start machine, the E-Stop switch should be up (green band will be visible). There is also a seat safety switch (operator must be properly seated for machine to operate). Push the On/Off button to start machine.

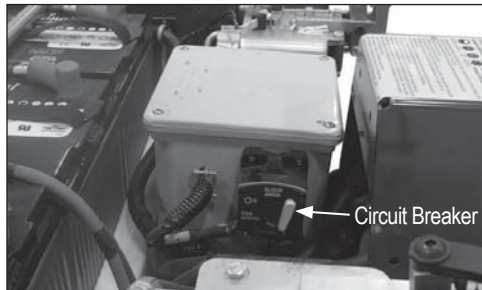

FIG. E

## MACHINE START-UP PROCEDURE

- Verify 70 amp circuit breaker is in "On" position (Figure E).
- Verify 48-volt blue plugs are firmly connected (Figure F).
- Operator should be properly positioned on seat.
- Twist E-Stop (Figure B) to "up" position exposing green ring.
- Push green "On" button.
- Maneuver machine with hydraulic levers (see instruction below).

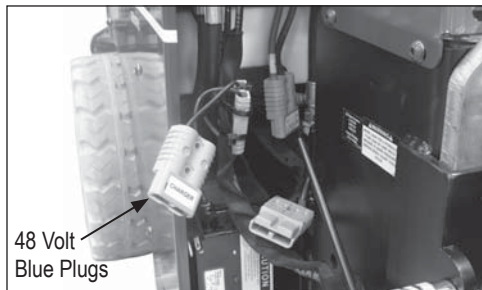

FIG. F

## HYDRAULIC LEVERS (FIGURE G)

The hydraulic levers steer the machine. They are feathered spool valves. For smooth even movement, always move levers slowly. Fast movement on control levers will result in jerky, uneven movement.

- Move levers slowly.
- Both levers forward  $\uparrow\uparrow$  move the machine forward.
- Both levers backward  $\downarrow\downarrow$  move the machine backward.
- The left lever forward and the right lever backward  $\uparrow\downarrow$  turn the machine quickly to the right.
- The left lever backward and the right lever forward  $\downarrow\uparrow$  turn the machine quickly to the left.
- Only using the left or right lever forward  $\uparrow$ , turns the machine slowly to the right or left.
- Only using the left or right lever backwards  $\downarrow$ , turns the machine slowly to the left or right.
- Correcting direction while moving forward is accomplished by slightly reducing pressure on one lever or the other while moving.
- The center position on levers causes wheels to lock-up.
- Always chock wheels and tie down machine when transporting.



FIG. G

# Machine Operation

## EMERGENCY STOP SWITCH (FIGURE H)

The emergency stop switch is designed to kill the power to the system.

## SEAT SWITCH

The seat has a safety switch. Operator must be properly positioned for machine to run.

## TO STORE MACHINE (FIGURE I & J)

When the machine is in storage, remove the blue connections and turn circuit breaker to off. This will help to keep someone from operating the machine when it shouldn't be.

## CYLINDER LIFT (FIGURE K)

The cylinder lift lever raises and lowers the cylinder and cutting head. After setting slide plate to proper height, use the cylinder lift lever to set blade to proper cutting angle.

Pull back ↓ on the cylinder lift lever to raise the cutting head. Push the cylinder lift lever forward ↑ to lower the cutting head. Continuing to push the cylinder lift lever forward and it will adjust the angle of the cutting head. This will also jack up the front of the machine (Figure K). This will need to be done when doing maintenance on the machine (ie: wheel changing, front caster maintenance etc). When doing machine maintenance, besides raising the cutting head angle, place blocks under the machine (Figure L). Never use the cutting head only.

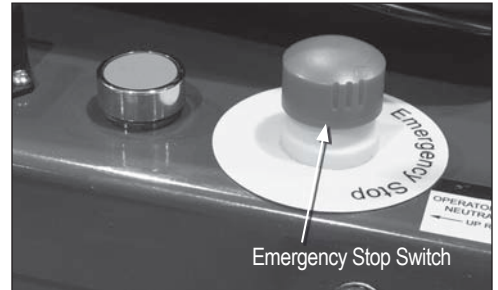
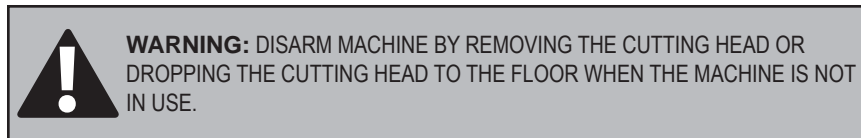
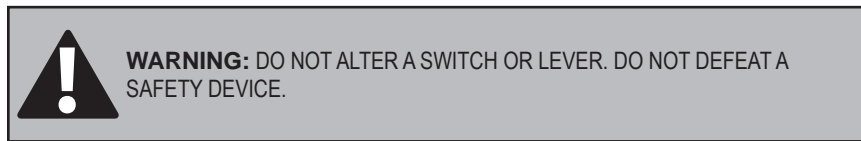

FIG. H

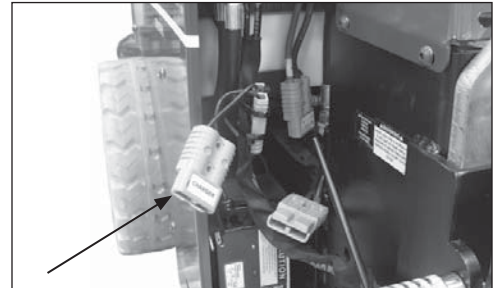

FIG. I

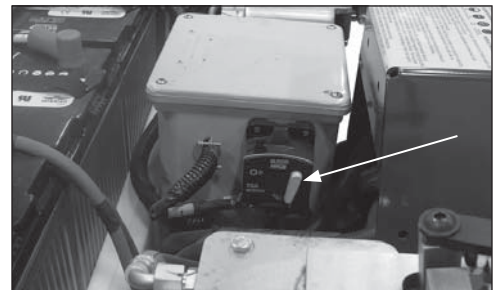

FIG. J

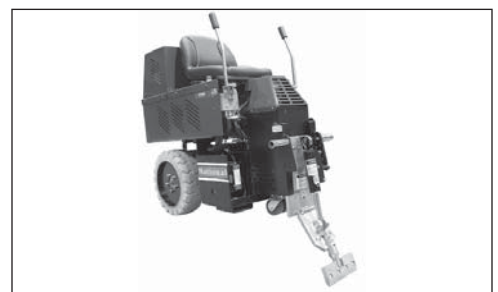

FIG. K

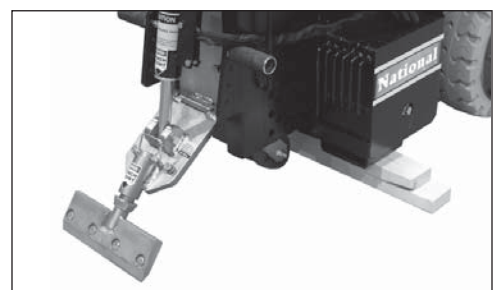

FIG. L

# Machine Operation

---

## CASTER

Keep clean and free of debris, make sure it can move freely. Clean as needed. Inspect before each use. Grease once a month.

Moving a “weighted” machine only on the front caster and not on the cutting head or the Front Wheel Assembly can seem to make the machine turn sluggish. It might turn hard to the right or the left; this is normal.

## FOOT PEG

Keep feet resting and secured on foot pegs when operating machine. Foot pegs are adjustable. Make sure securing nut is securely tightened

## SEAT

Always be properly seated before operating machine. Machine will not run if the operator is not properly seated

## DISARM MACHINE

Remove blade or drop cutting head to the floor when machine is not in use.

## TURN MACHINE OFF

Never change cutting head or service blade while machine is running.

## LEAKAGE

Keep fittings and hoses tight. If a leak is noticeable, retighten fitting. If leakage persists, remove the connection and inspect.

## ANGLE OF THE HEAD IS SET STEEP

When raising the front of the machine to a steep angle, the bottom of the slide plate should be raised so it is higher or even with the bottom of the guide channels, 6” to 7” (15.2 to 17.8 cm) off the floor. This will allow for a steep blade angle without tipping the machine too far back (usually used for re-scrape). The most common mode for take up, is the slide plate is almost to the floor (1/4” to 1/2” from the floor).

## RAISING OR LOWERING THE SLIDE PLATE

This will only work without a cutting head inserted in the machine. Completely loosen slide plate bolts. Use cylinder lift lever to raise or lower machine to move slide plate up or down.



**WARNING:** ALWAYS DISCONNECT ON BOARD CHARGER BEFORE OPERATING MACHINE.



# Machine Operation

## LOADING/UNLOADING

- Always remove blade and cutting head when machine is being moved or transported
- Cutting head and slide plate can be removed to make the machine more compact.
- NEVER leave machine unattended on an incline.
- Removing added weights help to make the machine easier and safer to move in and out of a vehicle.

 **WARNING:** MACHINE HAS A SWIVEL FRONT CASTER. NEVER SIDE HILL (SEE FIGURE A). THE MACHINE ON A INCLINE WITHOUT POWER, THE FRONT CASTER WILL CAUSE MACHINE TO SWING TO THE LOWEST POINT. IF IT IS NECESSARY TO RUN MACHINE ON AN INCLINE, RUN MACHINE ON CUTTING HEAD. PLACE AT LEAST A 8" CUTTING HEAD IN MACHINE. TO KEEP FROM DAMAGING FLOOR, CLAMP A PIECE OF CARPET INTO CUTTING HEAD TO SLIDE ON THE FLOOR. THIS WILL GIVE POSITIVE CONTACT WITH THE FLOOR WHEN POWER IS DISENGAGED FROM THE WHEELS.

## DOCK HEIGHTS

It is best to load or unload the machine from a level/equal dock height (a van from a van dock height, a truck/semi from a regular dock height).

## POWER-GATE

A power-gate can be used when the dock height is not available. Make sure gate is properly rated for 2300 lb (1043 kg). Make certain the machine is secure so it does not roll off the power-gate. To better secure machine, raise machine onto the lowered cutting head, raising machine off the caster. Tie machine down, chock wheels.

## RAMPS

To be safe, the ramp needs to be very long to accommodate the machine being loaded/unloaded. Remove added weight. Make sure ramp is secured. Do not have at a steep incline. The use of a power winch or hand come-a-long is much safer. For a van, the ramp should be 12 to 18' (3.6 to 5.5 m) in length depending on the depth of the incline. For truck height taller than a van, longer ramps will be needed. See OSHA guidelines. It is not recommended to drive the machine, connected with power, on a ramp. Make sure ramp is secure and has good contact before using. Failure to do so could cause ramp to fall away from the vehicle.

**NOTE:** SEE CORRECT AND SAFE OPERATING ANGLES AND CENTER OF GRAVITY ON PAGE 18.

## FORKLIFT CUPS

There are two forklift cups mounted under the front of the machine (See Figure O). Slide fork lift forks through forklift cups. Slide forks all the way back to touch the rear tire (See Figure P). Before lifting machine, secure machine to fork lift with heavy 3000 lb (1365 kg) or heavier rope or chain. Tilt forks back to lift machine (See Figure Q).

## WINCHES

Winches should be used for safety when loading or unloading with ramps. 2000 lb (900 kg) winch minimum.

## TRANSPORTING

Secure machine down with ratchet straps when transporting the machine. Chock wheels to keep machine from rolling, hydraulic levers should not be locked in the forward or backward position. Hydraulic levers should be straight up in the "neutral" position. This helps to lock drive wheels. Lift machine off swivel caster by lowering cutting head for better stabilization. Proper securing straps need to be rated at least twice the weight of the machine.

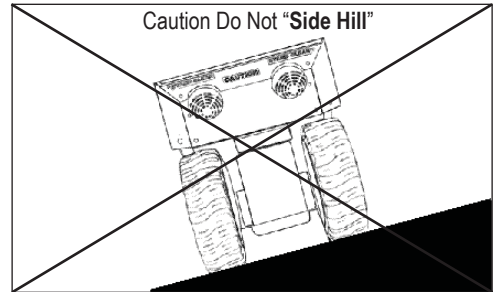

FIG. M

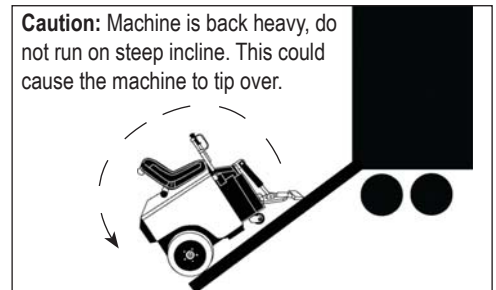

FIG. N

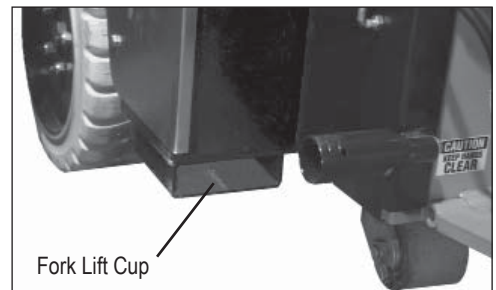

FIG. O

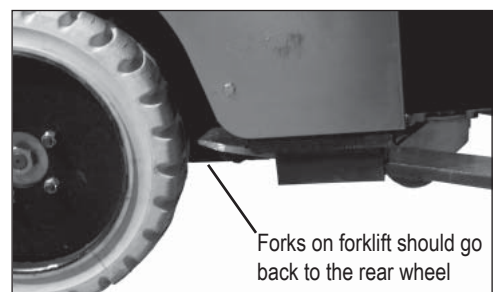

FIG. P

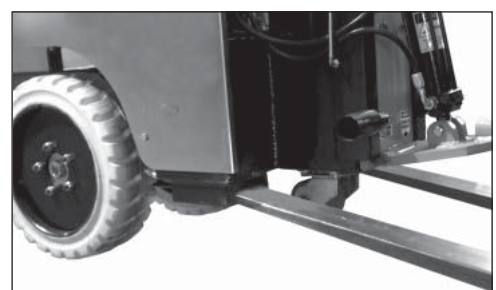

FIG. Q

# Machine Operation

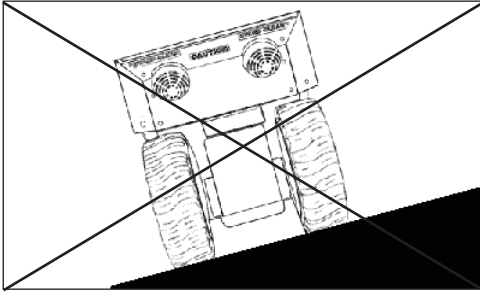

FIG. R

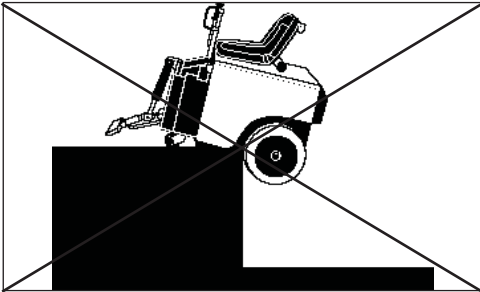

FIG. S

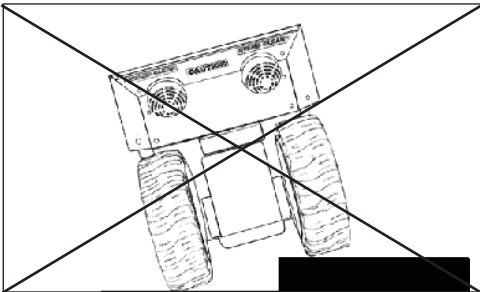

FIG. T

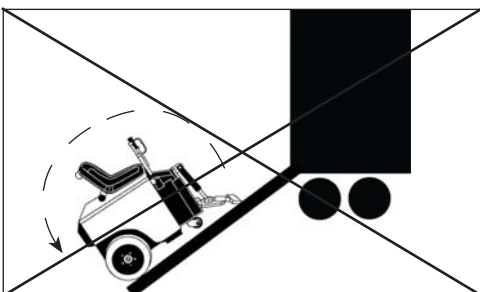

FIG. U

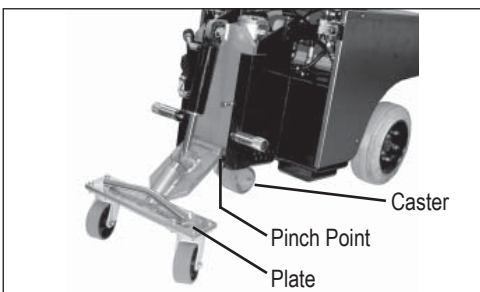

FIG. V

## WHEEL CHOCKS

Wheel chocks will help to secure the machine but DO NOT use wheel chocks alone to secure the machine.

## CENTER OF GRAVITY

Be aware of your surroundings and machines operating angles. When changing from a low slide plate to a high slide plate setting or a low cutting head angle to a high cutting head angle, the operating “attitude” of the machine changes. When a floor surface is not level (ramps, inclines, large amounts of debris which would lift the drive wheel of the machine, etc.), the center of gravity changes (See Figure R, S, T & U). Too much of an angle could make the machine unsafe (a cause for tip-over). **Do Not** run the machine in unsafe environments.

## JOB SITE MOVEMENT

- Always remove blade and cutting head when machine is being moved or transported
- Cutting head and slide plate can be removed to make the machine more compact.
- NEVER leave machine unattended on an incline.
- Removing added weights help to make the machine easier to move.

## TAPING WHEELS

Taping the wheels with a wide masking tape helps to prevent damage and dirt to floors during move-in and move-out.

## LEAP FROGGING BOARDS

Leap frogging boards help to protect floors from damage. Use two or three ¼” luan or plywood sheets, approximately 27” (68.58 cm) wide by 6’ (1.8 M) long. Cover one side of the board with a thin a carpet. With the carpet side to the floor, place a board in front of the machine. Drive onto the board. Set the next board in front of the machine. As you drive off one board, pick it up and set it in front of the machine.

## PALLETIZING

Only use a solid platform pallet. If a solid platform pallet is not available, place a piece of ¾” plywood on top of a pallet. Using a forklift with the forks inserted in the forklift cups, place machine on pallet. Use ratchet straps to secure machine to pallet.

## FRONT WHEEL ASSEMBLY (FIGURE V)

The Front Wheel Assembly is an optional attachment (#5110-100) that is very helpful when moving the machine around on a job-site or loading the machine that is not on a pallet. It allows machine stability and safe transportation over most surfaces. It is easy and quick to attach or detach. Raise slide plate so the bottom of the slide plate is higher or even with the bottom of the guide channels. Raise cylinder, insert Front Wheel Assembly into cutting head. Secure with securing pin.



**CAUTION:** WHEN MOVING THE SLIDE PLATE, BE AWARE OF PINCH POINT AT THE BOTTOM OF THE PLATE. FAILURE TO DO SO COULD CAUSE SERIOUS BODILY INJURY.



**WARNING:** PROTECT OTHERS IN WORK AREA. PROVIDE BARRIERS OR SHIELDS AS NEEDED TO PROTECT OTHERS FROM DEBRIS AND MACHINE OPERATION. OPERATOR SHOULD BE AWARE OF WHO IS AROUND THEM AND THEIR PROXIMITY.

NOTE: Make sure the plate is parallel with the floor so the caster swivels freely.

# Machine Operation

## TO MOVE MACHINE WITHOUT POWER (PUSHING MACHINE)

**Forward:** To move the machine forward, levers need to be pushed forward. To lock levers in place, connect a bungee-strap from each lever (pushing levers forward), pulling straps down to and connecting to the front plate (See Figure W). Never leave machine unattended with strap holding levers open.

**Backward:** To move machine backward, levers need to be pulled backwards. To lock levers in place, connect a bungee-strap from each lever (pushing levers backward), Pulling straps to the back of the machine and connecting behind the seat or the rear of the machine (See Figure X). Never leave machine unattended with strap holding levers open.

## MOVING MACHINE ON CASTER

Moving a “weighted” machine only on the front caster and not on the cutting head or the Front Wheel Assembly can seem to make the machine turn sluggish. It might turn hard to the right or the left; this is normal.



FIG. W



FIG. X



**WARNING:** ALWAYS REMOVE STRAPS BEFORE STARTING MOTORS. FAILURE TO DO SO WILL MAKE MACHINE MOVE AND MAY CAUSE PROPERTY DAMAGE AND/OR BODILY INJURY.

## WHEEL SIZE

The 18” (45.72 cm) wheel comes standard on the machine. This wheel will work on all job types of application and heavy debris build-up (VCT, ceramic etc.). It also works best for slippery/slimy residue, ie. double stick.

Keep wheels clean and free of debris, make sure it can move freely. Clean as needed. Inspect before each use.

To change wheels, see **Wheel Changing** on page 30.



**WARNING:** WHEN DOING MAINTENANCE OR CHANGING A WHEEL, MAKE SURE MACHINE IS SUPPORTED PROPERLY OR SERIOUS INJURY COULD OCCUR.

# Machine Operation

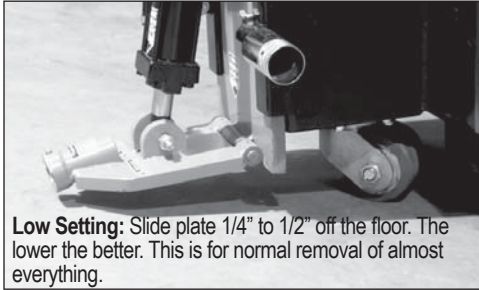

FIG. Y

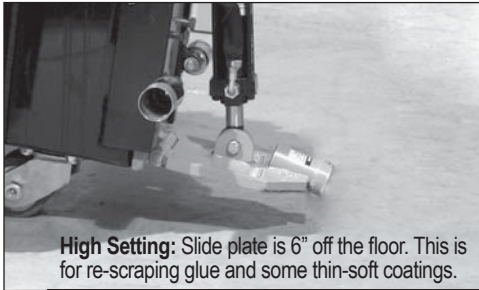

FIG. Z

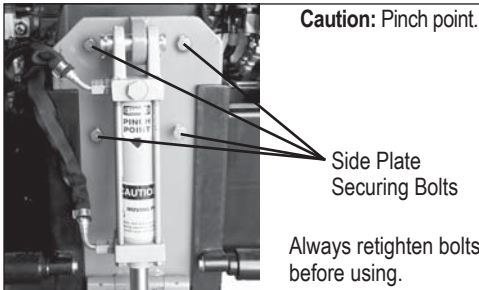

FIG. AA

## CUTTING HEAD & BLADES

### DIALING IN THE MACHINE

Dialing in the machine is matching the correct cutting head, blade size, blade angle and added weight to the machine to make the material removal as easy as possible. For every material being removed, there is an optimum blade width, thickness, sharpness, angle and bevel (bevel up or bevel down).

### SAVING TIME WITH EXTRA CUTTING HEADS

The machine is supplied with one cutting head. Having additional cutting heads will save time on the job. Insert blades into the extra cutting heads before starting a job. When the blade is dull, instead of taking the time to replace it or sharpen it on the job, take out the cutting head and replace it with another. Or when a different type or size of blade is needed, you have them ready to use.

### ADJUSTING SLIDE PLATE AND CUTTING HEAD (FIGURE Y & Z)

**Caution:** Pinch point. When adjusting slide plate, keep feet and hands out from underneath the cutting head and slide plate. Failure to do so could cause severe bodily injury. When bolts are removed from the slide plate, the cutting head and the slide plate will drop down to the floor.

- Loosen the two bolts on the front of the slide plate with a 3/4" wrench (see Figure AA).
- Slide plate up or down to achieve the desired height of the cutting head.
- Firmly retighten both bolts.

### SHEAR POINT

The shear point is the point where material to be removed will cut cleanly from the floor. If the blade is too wide, too dull, or too steep, the shear point is lost.



**CAUTION:** BLADES ARE SHARP, USE EXTREME CAUTION.



**CAUTION:** NEVER CHANGE CUTTING HEAD OR SERVICE BLADES WHILE MACHINE IS RUNNING.



**WARNING:** DISARM MACHINE WHEN MACHINE IS NOT IN USE. REMOVE THE CUTTING HEAD OR DROP CUTTING HEAD TO THE FLOOR. FAILURE TO DO SO COULD CAUSE SEVERE BODILY INJURY.

### WEIGHT VS. SHARPNESS

The most common way to compensate for a dull blade is to add more weight and raise the blade angle (see **Re-scrape** setting Page 23). Weight allows dull blades to be used to a point. Weight also causes blades to dull and break easier. Blades of any thickness tend to catch cracks and expansion joints and will bend or break the blade if set at a high angle. For best results, run a small ditching blade at a low angle to identify as many cracks and joints as possible. If blades are breaking, you are misunderstanding the conditions.

### CUTTING HEAD ANGLE

Set the cutting head angle to where the material comes up the easiest. The lowest is usually the best.

# Machine Operation

## STEEP CUTTING HEAD ANGLE

A steep angle is only used for re-scraping. The slide plate has to be raised so the bottom of the slide plate is higher or even with the bottom of the guide channels (see Figure BB). Not raising the slide plate when operating the machine at a steep angle will cause the machine to jump and buck. It does not give the operator a clear vision of the cutting head and it raises the machine to operate at a unsafe operating height (see Figure CC). Failure to raise the slide plate could cause machine damage and/or bodily injury.

## SWIVEL HEAD

The swivel head keeps the blade in contact with the floor even when the floor is uneven. When using a flat blade, by swiveling the head over 180° allows another sharp edge on the blade without having to replace the blade.

## CUTTING HEAD INSERTION

With machine off, insert desired cutting head into cutting head holder. Secure with cutting head clip.

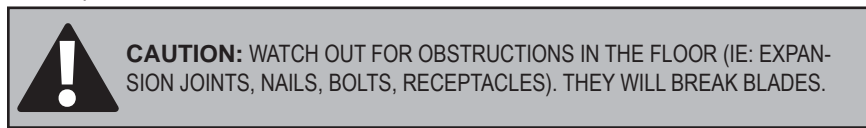

## SHANK BLADE INSERTION

Shank blades do not require a cutting head. Insert desired shank blade into cutting head holder. Secure with cutting head clip.

## BLADE SETTING

- Dull blades greatly reduce cutting ability. Re-sharpen or replace as needed.
- Proper blade size and placement, depending on material and sub-floor type, affects performance.
- The harder a job comes up, for best results, use a smaller blade.
- Start with a narrow blade, then increase blade size to optimize cutting pass. Narrower blades work easier than wider blades and usually clean the floor better. Wider is not always better or faster.
- Normally bevel on blade is up for concrete. Bevel down for wood and shoe blades for soft sub-floors.



- KEEP BLADES SHARP.
- Dull blades greatly affect the performance of the machine and reduce cutting ability, resharpen or replace as needed.
- Keep your work area clean and clear of debris.
- After you have removed a portion of material, remove it out of the way. This will give the machine maximum performance and help to keep the work area safe.
- Always wear gloves when handling blades.
- Everyone in work area should wear eye protection.

## SELF-SCORING BLADES

Instead of pre-scoring a job, for soft goods (carpet, vinyl, linoleum, membrane) the self-scoring blades automatically do the scoring.

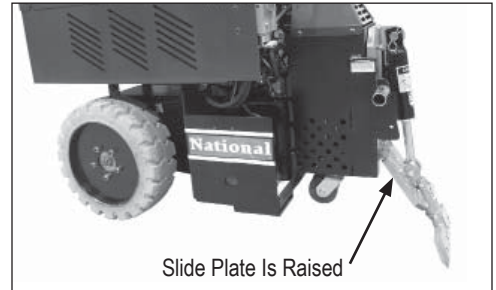

FIG. BB

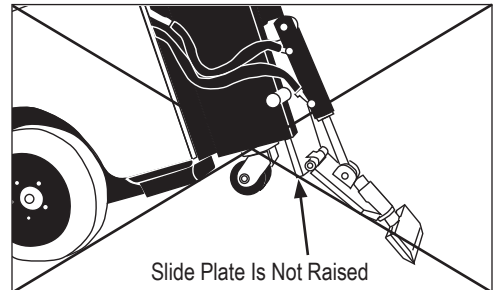

FIG. CC

# Machine Operation

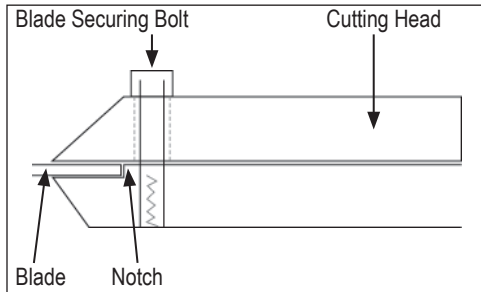

FIG. DD

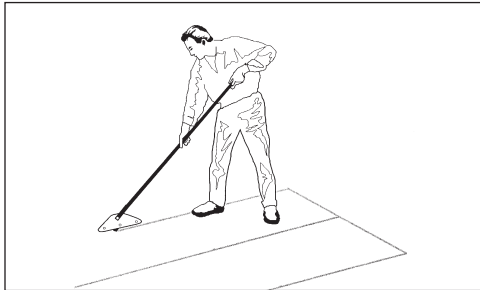

FIG. EE

## BLADE INSERTION OR BLADE CHANGING

Using a 3/4" socket wrench, loosen bolts on cutting head. Quantity of bolts will vary depending upon cutting head size. Insert blade into the cutting head to back of notch (See Figure DD). Tighten firmly.

Note: A cordless 3/8" drive impact wrench will speed up this process especially out on the job.

- Sharp blades are imperative for good performance.
- Always wear gloves when handling blades.



**WARNING:** BLADES ARE SHARP, USE EXTREME CAUTION.



**WARNING:** NEVER CHANGE CUTTING HEAD OR SERVICE BLADES WHILE MACHINE IS RUNNING.



**WARNING:** DISARM MACHINE WHEN MACHINE IS NOT IN USE. REMOVE THE CUTTING HEAD OR DROP CUTTING HEAD TO THE FLOOR. FAILURE TO DO SO COULD CAUSE SEVERE BODILY INJURY.

## CERAMIC SET-UP

The slide plate should be adjusted to a low setting 1" (2.5 cm) off the floor. Use a Shank Blade or a Shank Blade with a carbide tip.

## WOOD SET-UP

The slide plate should be adjusted to a low setting 1" (2.5 cm) off the floor. Use Shank Blades, Shank Blades with carbide tips or a 6" or 8" (15 to 20 cm) Cutting Head with Shoe Blades, Bent Shoe Blades or Heavy Duty Blades. Note: Run machine 45° to the grain of the wood.

## SECONDARY BACKING CARPET SET-UP

The slide plate should be adjusted to a low setting 1" (2.5 cm) off the floor. Use a Cutting head from 10" to 27" (25 to 68.5 cm) with Heavy Duty Blades or a Cutting Head from 10" to 14" (25 to 35.5 cm) with a Self-Scoring Blade.

## FOAM BACK CARPET SET-UP

The slide plate should be adjusted to a low setting 1" (2.5 cm) off the floor. Use Cutting Heads from 10" to 14" (25 to 35.5 cm) with Self-Scoring Blades. If it is not stuck tight, use a Cutting Head from 14" to 27" (25 to 68.5 cm) with a Standard Blade.

## DOUBLE STICK CARPET SET-UP

The slide plate should be adjusted to a low setting 1" (2.5 cm) off the floor. It is best to test to see which is the easiest way to remove double stick. Start with a Cutting Head from 10" to 14" (25 to 35.5 cm) with Self-Scoring Blades (Figure HH). If self-scoring blades do not work, score thru the carpet (Figure II) the width of the blade (Standard Blade) and scrape up. In some cases, carpet might pull off the pad and then scrape up the pad separately. Usually leaving carpet connected to the pad works the best. Sharp blades are necessary for proper operation.

Note: When removing carpet from over VCT Tile and the tile needs to be saved, run the machine at a 45° angle over the tile. This should help to save the tile.

# Machine Operation

## VCT TILE SET-UP

The slide plate should be adjusted to a low setting 1" (2.5 cm) off the floor. If goods come up easily, change to a larger Cutting Head. If goods come up harder, use a Cutting Head from 6" to 8" (15 to 20 cm) with a Premium High Tempered Blade (.062) to match cutting head size. Sometimes a .094 blade may work better. If goods remove easily, a Tile Box #7074 can be used. A tile box also works for wind rowing, assists for a fast clean-up and collection of tile debris for quick removal.

## RUBBER TILE SET-UP

The slide plate should be adjusted to a low setting 1" (2.5 cm) off the floor. Use a Cutting Head from 6" to 14" (15 to 35.5 cm) with self-scoring blades or use ditching method with a flat blade.

## RE-SCRAPING SET-UP

Slide plate should be set high, 6" to 8" (15 to 20 cm) off the floor. Use a Cutting Head from 8" to 27" (20 to 68.5 cm) with Scraper Blades to match cutting head size. A 15" scrapper blade would use a 14" Cutting Head. Razor Blades are faster but a Cutting Head from 8" to 14" (20 to 35.5 cm) can be used with a Standard Blade. Flip head regularly.

## THIN COATING SET-UP

Slide plate could be set high, 6" to 8" (15 to 20 cm) or low 1" (2.5 cm) off the floor. Test to see which works best. Use a Cutting Head from 8" to 27" (20 to 68.5 cm) with Razor Blades to match cutting head size.

## WORKING OVER CONCRETE

Blade should be bevel up when working over concrete. Pretty much anything over concrete works. Try different set-ups to see which works best. If goods come up difficult, the slide plate should be at a low setting, 1" (2.5 cm) off the floor. Use a smaller size blade. If goods come up easily, a wider blade can be used.

## WORKING OVER WOOD

A heavy machine cannot be used on wood subfloors or raised panel computer floors. Keep machine light, remove all weights. A weighted machine could break through the floor. The slide plate should be adjusted to a low setting 1" (2.5 cm) off the floor. Blades should be as flat of an angle as possible. Use a "shoe blade", Extra Heavy Duty Blade (these blades have a bend to them) or a regular blade, bevel up. When using a regular blade, bending up the corners of the blade will help from the blade digging into the floor. Sometimes a shank blade or a shank blade with a carbide tip will work. Allow blade to shear material from the floor. The trick on wood floors is to run the blade flat. Approach should be at a 45° angle to the board. This keeps from digging into the board and hanging up at the seams.

## WORKING OVER SOFT SUB-FLOOR

The slide plate should be adjusted to a low setting 1" (2.5 cm) off the floor. Blades should be as flat of an angle as possible. Use a "shoe blade", Extra Heavy Duty Blade (these blades have a bend to them) or a regular blade, bevel up. When using a regular blade, bending up the corners of the blade will help from the blade digging into the floor. Sometimes a shank blade or a shank blade with a carbide tip will work.



**CAUTION:** BLADES ARE SHARP, USE EXTREME CAUTION.



**CAUTION:** NEVER CHANGE CUTTING HEAD OR SERVICE BLADES WHILE MACHINE IS RUNNING.



**WARNING:** DISARM MACHINE WHEN MACHINE IS NOT IN USE. REMOVE THE CUTTING HEAD OR DROP CUTTING HEAD TO THE FLOOR. FAILURE TO DO SO COULD CAUSE SEVERE BODILY INJURY.

# Machine Operation

## DITCHING

### CROSS ROOM DITCHING

When removing hard to remove ceramic, Vct or vat, cross-room ditching will help to make the removal easier. Using a blade 2" to 6" (5 to 15.25 cm) in width, make ditches 1' to 2' (30.5 to 61 cm) apart in the same direction the machine will be removing the goods (See Figure FF). This "relieves" the pressure holding the tiles together. If ditching helps and the goods are coming up easy, try using a wider blade to ditch with.

### CHECKER BOARD DITCHING

To make carpet removal and debris cleanup easier, checker board ditching is very helpful. Using as wide of a self-scoring blade as possible, make ditches 4' to 6' (1.2 to 1.8 m) apart crossways from the way the machine will be removing the goods (See Figure GG). Running the machine crossways from the ditches will make smaller pieces of debris to be hauled away. Instead of large gummy rolls of carpet, there are small squares that can be rolled, palletized, put on a dolly or folded with the sticky side in. This makes removing the debris easier and reduces the amount of debris.

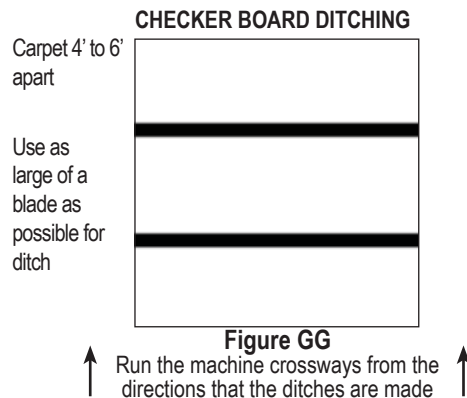
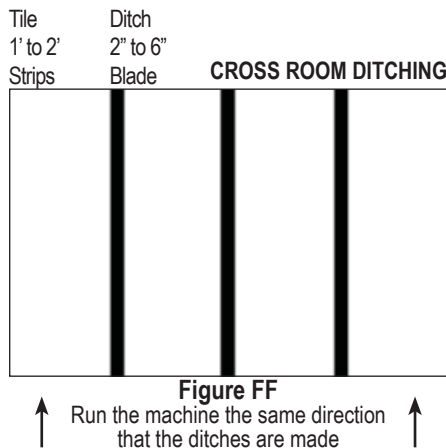

## BLADE SHARPENING

Dull blades greatly reduce cutting ability. Re-sharpen or replace as needed. In use, blades develop a back-bevel (See Figure HH). When re-sharpening, blade will not be truly sharp until all back-bevel is gone.

**Note:** Thinner blades are easier to sharpen, but they also break easier.

- Always wear gloves and safety glasses.
- Grind blade using a 4" diameter disk with 120 or finer grit. Be careful not to catch disk on edge or corner of blade.
- Pass grinder back and forth along blade edge being careful to hold grinder at proper angle of blade. Grind until sharp.
- Using a good quality fine tooth hand file, use same procedure as above.
- Blades are sharp. Use extreme caution.
- Have plenty of sharp blades on each job so on-the-job blade sharpening is eliminated.
- It is best to resharpen dull blades on proper bench or belt grinder in the shop, so the blades are ready for the next job.

### SELF-SCORING BLADE SHARPENING

It is important to keep the "wings" on a self-scoring blade sharp (See Figure II). Use a file on the "wing" edge. Sharpen the flat part of the blade, the same way as described above.

### CARBIDE TIPPED BLADE SHARPENING

To sharpen carbide tipped blades, a wheel to grind carbide is necessary, ie: green wheel or diamond wheel.

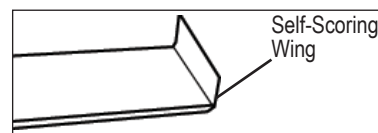
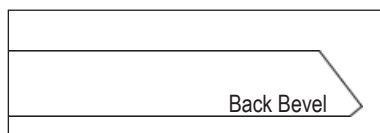



## STANDARD BLADE (FIGURE JJ)

This heavy duty blade is designed to remove soft goods, carpet, and vinyl flooring. Its .062 thickness offers flexibility to maximize the shear point angle.

PART#	DESCRIPTION	THICKNESS (IN.)
135	5" X 16" BLADE	.062
147	4" X 6" BLADE	.062
148	5" X 6" BLADE	.062

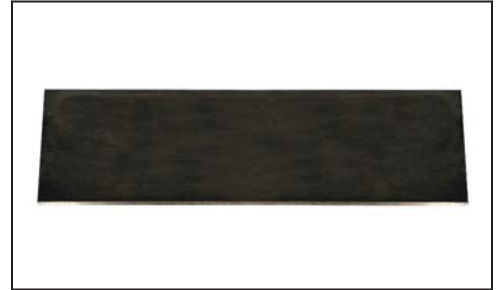

FIG. JJ

## RAZOR/SCRAPER BLADES (FIGURE KK)

These razor sharp blades are designed for super hard thin epoxies, thin mil coatings (like urethane paint), poured elastomeric coatings up to 60 mil and hard to remove adhesives.

PART#	DESCRIPTION	THICKNESS (IN.)
363-2	3/4" X 8" RAZOR/SCRAPER BLADE (50/PKG)	.032
368-8	7/8" X 8" RAZOR/SCRAPER BLADE (50/PKG)	.045
368-12	7/8" X 12" RAZOR/SCRAPER BLADE (50/PKG)	.045
368-15	7/8" X 15" RAZOR/SCRAPER BLADE (50/PKG)	.045

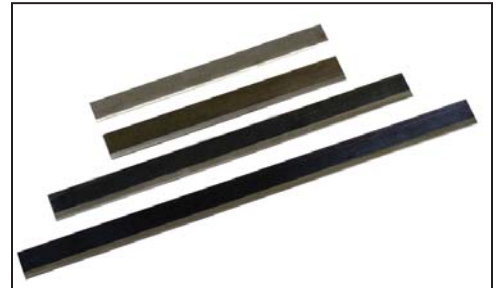

FIG. KK

## SELF-SCORING BLADES (FIGURE LL)

These 90° angled self-scoring wing tipped blades are tough and long lasting. Made from National's proven blade hardening process, they perform up to ten times longer than the competition. They work on attached cushion, unitary or secondary backing, vinyl back, soft to medium PVC, linoleum, carpet tiles, soft cork, enhancer and unibond hot melts.

PART#	DESCRIPTION	THICKNESS (IN.)
6258-BU	3" X 12" SELF-SCORING BLADE	.062
6259-BU	3" X 14" SELF-SCORING BLADE	.062
6260-BD	3" X 6" HEAVY DUTY DITCHING	.094
6276-BU	3" X 10" SELF-SCORING BLADE	.094
6277-BU	3" X 12" SELF-SCORING BLADE	.094
6278-BU	3" X 14" SELF-SCORING BLADE	.094

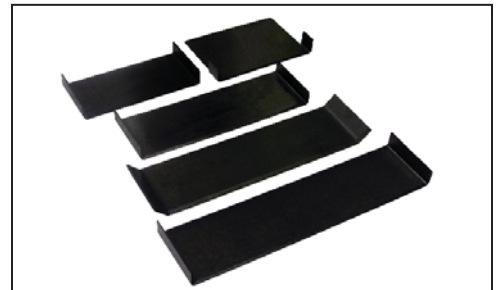

FIG. LL

## HEAVY DUTY BLADES (FIGURE MM)

This heavy duty blade is flexible and delivers jobsite versatility. Made with National's proven blade hardening process, these blades will stay sharper longer with better overall performance than any other blade on the market. They work on VCT, VAT, wood, tile, rubber, epoxy, elastomeric coatings, scraping thin-set and glued ceramic.

PART#	DESCRIPTION	THICKNESS (IN.)
6281	3" X 8" HEAVY DUTY BLADE	.094
6282	3" X 14" HEAVY DUTY BLADE	.094
6284	3" X 12" HEAVY DUTY BLADE	.094
6285	3" X 6" HEAVY DUTY BLADE	.094
6286	3" X 10" HEAVY DUTY BLADE	.094



FIG. MM

## EXTRA HEAVY DUTY BLADES (FIGURE NN)

These extremely hard, high abrasion alloy blades are designed for tough tear up situations. VCT, VAT, wood, tile, lighter ceramic, rescraping thin-set, all carpets, cork, elastomeric coatings, rescraping rubber and urethane coatings. They hold all edges extremely well.

PART#	DESCRIPTION	THICKNESS (IN.)
6290	3" X 6" EXTRA HEAVY DUTY BLADE	.187
6291	3" X 8" EXTRA HEAVY DUTY BLADE	.187
6292	3" X 12" EXTRA HEAVY DUTY BLADE	.187
6293	3" X 14" EXTRA HEAVY DUTY BLADE	.187



FIG. NN

# Blades



FIG. OO

## PREMIUM HIGH TEMPERED BLADES (FIGURE OO)

Ultra high quality spring steel is extra hard for long blade life between sharpening. Works on all glued down carpets, VCT, VAT, rubber tile, cork, re-scraping adhesive, elastomeric coatings. Great for floor accumulations.

PART#	DESCRIPTION	THICKNESS (IN.)
7050-200	3" X 6" PREMIUM HIGH TEMPERED BLADE	.062
7050-201	3" X 8" PREMIUM HIGH TEMPERED BLADE	.062
7050-202	3" X 10" PREMIUM HIGH TEMPERED BLADE	.062
7050-203	3" X 12" PREMIUM HIGH TEMPERED BLADE	.062
7050-204	3" X 14" PREMIUM HIGH TEMPERED BLADE	.062
7050-205	3" X 27" PREMIUM HIGH TEMPERED BLADE	.062



FIG. PP

## STRAIGHT SHANK BLADES (FIGURE PP)

Works well for ceramic, wood and thick epoxy. The ultimate for the toughest removals. Made from an ultra tough alloy, which is put through special processing to give these blades unbelievable edge holding ability for ceramic epoxy, thin-set, mud set, decorative concrete toppings and much more.

PART#	DESCRIPTION	THICKNESS (IN.)
7070-2	4" X 2" STRAIGHT SHANK BLADE	.500
7070-3	4" X 3" STRAIGHT SHANK BLADE	.500
7070-4	4" X 4" STRAIGHT SHANK BLADE	.500
7070-6	4" X 6" STRAIGHT SHANK BLADE	.500



FIG. QQ

## ANGLE SHANK BLADES (FIGURE QQ)

Works well for ceramic and thick epoxy. The same application as the #7070 blades, but is mounted at an angle to achieve the optimum shear point for optimum performance.

PART#	DESCRIPTION	THICKNESS (IN.)
7071-2	4" X 2" ANGLE SHANK BLADE	.500
7071-3	4" X 3" ANGLE SHANK BLADE	.500
7071-4	4" X 4" ANGLE SHANK BLADE	.500
7071-6	4" X 6" ANGLE SHANK BLADE	.500



FIG. RR

## STRAIGHT SHANK W/ CARBIDE TIP (FIGURE RR)

Works well for ceramic and thick epoxy. The same application as the #7070 blades, but are carbide tipped for holding a sharp edge for long periods. Nothing else performs like carbide when no other blade will work. Works well on elastomeric coatings.

PART#	DESCRIPTION	THICKNESS (IN.)
7072-2	4" X 2" STRAIGHT SHANK W/ CARBIDE TIP	.500
7072-3	4" X 3" STRAIGHT SHANK W/ CARBIDE TIP	.500
7072-4	4" X 4" STRAIGHT SHANK W/ CARBIDE TIP	.500
7072-6	4" X 6" STRAIGHT SHANK W/ CARBIDE TIP	.500



FIG. SS

## TAPERED CUTTING HEAD SHANKS (FIGURE SS)

The longer taper works great on tough wood floors (glued & nailed). The long length allows the blade to easily slide under tough material. Works well on most ceramics and VCT.

PART#	DESCRIPTION	THICKNESS (IN.)
7075-8	2" X 8" TAPERED CUTTING HEAD SHANK	.300
7075-11	2" X 11" TAPERED CUTTING HEAD SHANK	.300
7077-8	3.5" X 8" TAPERED CUTTING HEAD SHANK	.300
7077-11	3.5" X 11" TAPERED CUTTING HEAD SHANK	.300

## TAPERED CUTTING HEAD SHANKS (FIGURE TT)

The longer taper works great on tough wood floors (glued & nailed). The long length allows the blade to easily slide under tough material. Works well on most ceramics and VCT. Carbide tipped for holding a sharp edge for long periods.

PART#	DESCRIPTION	THICKNESS (IN.)
7076-8	2" X 8" TAPERED W/ CARBIDE TIP	.300
7076-11	2" X 11" TAPERED W/ CARBIDE TIP	.300
7078-8	3.5" X 8" TAPERED W/ CARBIDE TIP	.300
7078-11	3.5" X 11" TAPERED W/ CARBIDE TIP	.300



FIG. TT

## ULTRA HEAVY DUTY CERAMIC EPOXY ANGLE SHANKS W/ CARBIDE TIPS (FIGURE UU)

Designed for ceramic removal and thin-set rescraping. 1/2" of carbide. The extra carbide allows for maximum resharping. Strong enough to work on machines up to 3500 lbs.

PART#	DESCRIPTION	THICKNESS (IN.)
7079-2	2" X 6" ULTRA HD CERAMIC EPOXY BLADE	.500
7079-4	4" X 6" ULTRA HD CERAMIC EPOXY BLADE	.500
7079-6	6" X 6" ULTRA HD CERAMIC EPOXY BLADE	.500



FIG. UU

## INCREASED ANGLE BLADES (FIGURE VV)

Mainly used for VCT, but can be used on most other applications. Supplies more of an angle when angle is needed. Prevents machine from jumping off material.

PART#	DESCRIPTION	THICKNESS (IN.)
7081	3" X 10" INCREASED ANGLE BLADE	.062
7083	3" X 8" INCREASED ANGLE BLADE	.062



FIG. VV

# Machine Maintenance

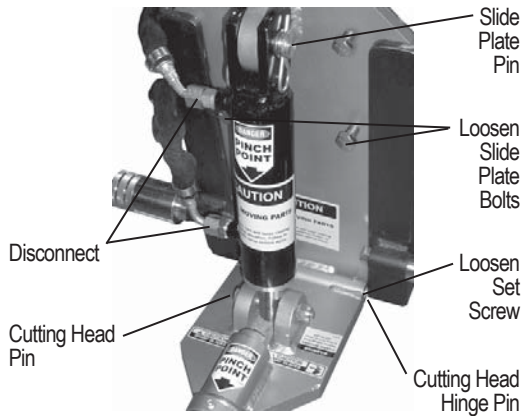

FIG. A

## SLIDE PLATE (FIGURE WW)

### TO REMOVE SLIDE PLATE

1. Disconnect machine from power.
2. Remove slide plate pin. Remove cutting head bolt. Remove cylinder from slide plate. Remove slide plate.

OR

1. Disconnect machine from power.
2. Disconnect hydraulic lines from cylinder. A small amount of oil leak out of lines. Cap lines or bleed into a container. Wipe up spillage immediately.
3. With lines removed, loosen slide plate securing bolts. Hold slide plate at the top of the cylinder. Take Caution: slide plate will drop to the floor when slide plate securing bolts are disengaged. Keep hands and feet out from underneath slide plate.
4. Remove slide plate, cylinder and lower cutting head support.

**Take Caution:** slide plate will drop to the floor when slide plate securing bolts are disengaged. Keep hands and feet out from underneath slide plate, failure to do so could cause severe bodily injury.

### RAISING OR LOWERING THE SLIDE PLATE

This will only work without a cutting head inserted in the machine. Completely loosen slide plate bolts. Use cylinder lift lever to raise or lower machine to move slide plate up or down.

### LOWER CUTTING HEAD SUPPORT

To Remove Lower Cutting Head Support:

1. Lower slide plate so cutting head hinge pin is below machine bottom. Retighten.
2. Loosen both cutting head pin set screws at the base of the lower cutting head support (hinge area).
3. Drive cutting head pin out using a punch and hammer.
4. Remove cylinder securing hex head bolt.

### LEAK MAINTENANCE

All fittings on this machine are O-ring style.

1. Disconnect machine from power.
2. If a leak is detected, tighten fitting with the proper wrench size. DO NOT over tighten. Over tightening could damage O-rings.
3. If a leak still persists, remove fitting and replace O-ring.

### HYDRAULIC FLUID LEVEL

To Check Hydraulic Fluid:

1. Remove Breather Dip Stick (See Figure B).
2. Check to see that Hydraulic Fluid is visible on Dip Stick.

OR

1. Remove Filler plug (See Figure C).
2. Oil should be visual 2" (5 cm) below hole.
3. Reinsert plug.

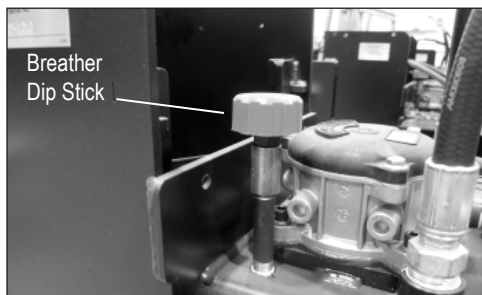

FIG. B

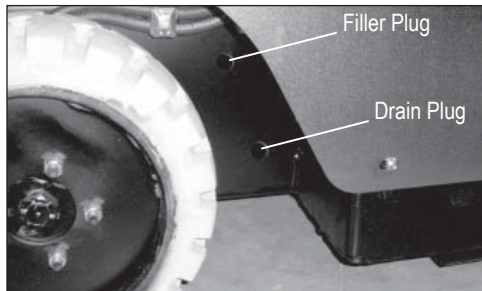

FIG. C

# Machine Maintenance

---

## HYDRAULIC OIL CHANGE OUT

1. Let Hydraulic fluid cool before maintenance.
2. Disconnect machine from battery.
3. Drain fluid by removing the drain plug from side of tank (See Figure YY). Take Caution: this unit contains twelve gallons of fluid. Make sure you have the proper amount of containers to catch fluid.
4. Replace drain plug.
5. Remove filler plug (See Figure YY).
6. Add oil into the filler plug hole until visual 2" (5 cm) below hole.

## HYDRAULIC CYLINDER CHANGE OUT

1. Disconnect machine from power.
2. Disconnect cylinder lines. Have a container ready to catch oil from lines.
3. Remove cylinder securing hexhead bolt from lower cutting head support.
4. Remove clips and pin from cylinder and slide plate.
5. Remove cylinder upper pin.
6. Remove cylinder.

## HOSE CHANGE OUT

To Remove or Change A Hose:

1. Disconnect machine from power.
2. Remove hood.
3. Using proper wrench size, remove hose from fitting.
4. When replacing, make sure O-ring is properly seated on hose fitting.

## FOOT PEG

To Remove or Replace Foot Peg:

1. Insert a socket wrench into foot peg and secure bolt head.
2. Remove nut and washer.
3. Remove bolt and foot peg.
4. Replace foot peg before operating machine. DO NOT use machine without foot pegs.

# Machine Maintenance

---

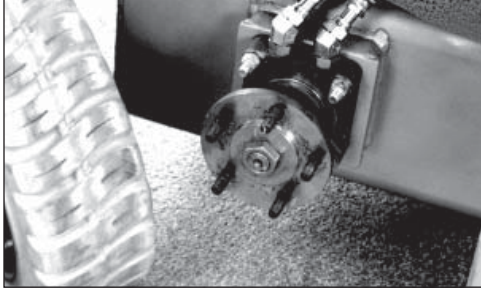

**FIG. ZZ**

## **PUMP CHANGE OUT**

1. Lift and secure hood.
2. Disconnect hydraulic lines.
3. Remove two 3/8"-16x1 pump bolts.
4. Remove pump by pulling pump straight out from pump motor.

## **VALVE CHANGE OUT**

1. Disconnect machine from power (charger or battery).
2. Lift hood and secure in place.
3. Remove hoses from valve body. have a container ready to catch leakage from lines.
4. Take notice of angle of valve fittings.
5. Remove two 1/4" bolts securing valve body.

## **WHEEL MOTOR CHANGE OUT**

1. Disconnect machine from power.
2. Block up machine to remove wheel. See wheel changing below.
3. Remove wheel.
4. Remove oil lines from wheel motor. A small amount of oil will run out of the lines. Drain into a container. Wipe up spills immediately.
5. Remove four 1/2" wheel motor securing nuts.
6. Pull out on wheel motor to remove.

## **WHEEL CHANGING (FIGURE ZZ)**

1. Jack machine up by pushing the cylinder lift forward to lower and adjust the angle of the cutting head to raise machine.
2. Place blocks under Forklift Cups on the side of the machine that wheel is being changed.
3. Take Caution: Make sure machine is supported properly or serious injury could occur.
4. Let cylinder down resting machine on blocks allowing rear wheel to be lifted off the floor.
5. Remove five 1/2" lug nuts with an extended arm wrench, remove wheel.
6. Replace wheel.
7. Replace five lug nuts and tighten, making sure lug nuts are very tight.
8. Raise cylinder to raise machine off of blocks. Remove blocks and lower machine.
9. Repeat to other side if necessary.

# Machine Maintenance

## CHANGING HYDRAULIC FLUID FILTER

Filter should be replaced yearly.

1. Remove old filter by turning counter-clockwise.
2. Install new filter by turning clockwise.

## SWITCHES

There are two switches:

- On (Start) Switch.
- Seat Switch.

**Do not defeat switches**

## SEAT REPLACEMENT

1. Remove four (4) button hexhead screws on each side of the hood (4 times).
2. Slightly raise seat plate & unplug wire harness.
3. Lift hood off.
4. Remove seat.
5. To replace seat, set seat on top of hood.
6. Replace the four 5/16 button hexhead screws from underneath the hood.
7. Firmly tighten.
8. Reconnect back-up beeper and seat switch wires.
9. Replace hood and screws.



FIG. AB

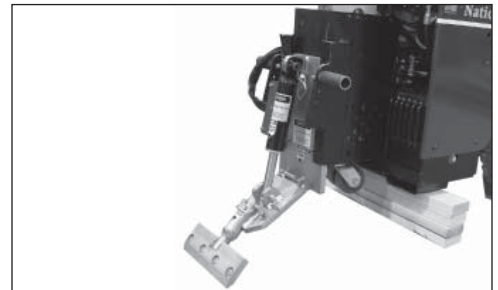

FIG. AC



**CAUTION:** THE BACKUP BEEPER IS ON THE MACHINE FOR SAFETY. IT IS IMPORTANT TO KEEP IT IN GOOD WORKING CONDITION. FAILURE TO DO SO COULD CAUSE BODILY INJURY.

## CASTER MAINTENANCE

1. Keep clean and free of debris, make sure it can move freely.
2. Give a shot of grease in grease zerc on caster every six months to keep moving freely.
3. To remove caster, machine will need to be raised. Push the cylinder lift lever forward to lower and adjust the angle of the cutting head to jack up the machine (See Figure AB). Block up machine (See Figure AC). Remove four bolts, pull caster off, clean/replace as needed.
4. Replace caster.
5. Replace and firmly tighten the four bolts.
6. Lower the machine.

# Machine Maintenance

## DEBRIS DEFLECTOR (#5200-258) MOUNTING INSTRUCTIONS

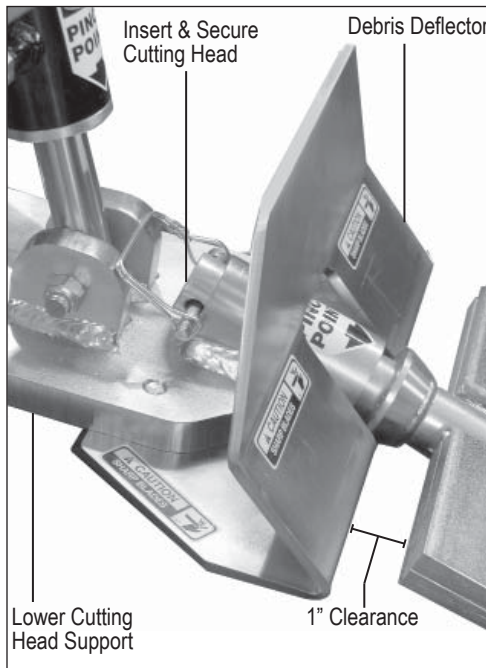

FIG. AD

1. **If there are holes on your lower cutting head support**, place debris deflector under the lower cutting head support and bolt in place.
2. **If there are not holes on the lower cutting head support**, place debris deflector on the lower cutting head support, measuring a 1" clearance between the cutting head and the front of the debris deflector. This clearance will reduce a "pinch point".
3. Secure with C-clamps.
4. Mark the holes from the debris deflector on the lower cutting head support.
5. Either drill a 1/2" hole on each mark and secure debris deflector with a bolt and lock nut **OR** drill a 27/64" hole and tap 1/2-13.
6. Firmly secure debris deflector.
7. Insert and secure a cutting head, making sure cutting head is **all the way in**.



# Troubleshooting Guide

Problem	Cause	Solution
Machine will not start.	Seat Safety Switch is engaged.	Make sure that you're sitting on the seat.
	The Emergency Stop (E-Stop) switch is engaged.	Twist the E-Stop switch to expose the green ring.
	The circuit breaker is in the OFF position.	Verify the circuit breaker is in the ON position.
	The 48 volt blue plugs are not connected.	Make sure that connection plugs are fully installed.
	The "start" button did not fully engage.	Firmly press down the green start button.
Machine doesn't run as long as it used to.	Battery is not fully charging.	Verify that you are charging machine with provided seven foot power cord. Verify that the charger is working properly. Charger has a LED light to indicate.
	The 48 volt blue plugs are not connected.	Check that the connection plugs are fully installed.
	Batteries no longer hold a charge.	Call National for procedure to have batteries load tested.
Machine is making rattling noises.	Loose hardware on machine.	Inspect and tighten bolts as needed.
Charger is hot.	Charger is in use.	This is normal.
Fluid is leaking from the machine.	Hose connections/ or fittings have loosened through normal use.	Tighten hydraulic hoses and fittings as needed.
	Pin hole in the hoses.	Replace affected hose.
	Oil and/or oil filter are old.	Replace oil and oil filter yearly on machine.
Tires/Wheel motors make a slight clicking noise.		Normal noise with proper operation.
Machine is jerky or jumpy.	New operator	Additional time is required to become familiar with machine.
	Control levers are being moved to quickly.	Operate control levers with wrist resting on knees for additional support or purchase arm rest.
Coupling leaks at thread or seat.	Missing or damaged O-rings.	Check for missing or damaged O-rings; replace if necessary.
	Damaged threads due to misalignment or improper seat angle.	Correct seat angle. Check for thread damage; replace if necessary.
	Over or under torquing.	Only hand tighten hardware.
Any issues not listed above.		Please contact NFE to speak with a technician.

# Complete Parts List

PART#	DESCRIPTION	QTY	PART#	DESCRIPTION	QTY
1	5215 ON BOARD CHARGER, 48V 115 V	1	54	5110-219 STRAIGHT VALVE BODY PLUG	8
2	70602 INSTRUCTION MANUAL TUBE	1	55	5110-233 BREATHER ASSEMBLY	1
3	70603 INSTRUCTION TUBE CAP	1	56	5110-234 RELIEF VALVE COUPLER (ONLY)	1
4	70612 BRACKET	1	57	5110-234-1 RELIEF VALVE NIPPLE (ONLY)	1
5	72385 5 HP MOTOR	1	58	5110-237 SUCTION FILTER SCREEN	1
6	72705 50 AMP 48 VOLT CHARGER CONNECTOR ONLY	1	59	5110-237-1 FILTER SUCTION LINE ASSEMBLY	2
7	72801 1/4" 90° FITTING	2	60	5110-237-1B SUCTION HOSE FITTING(ONLY)	4
8	72816 FITTING, ELBOW, 90 DEGREE, 3/8"	2	61	5110-250 CYLINDER	1
9	73005 1/4-20 X 1/2 HEXHEAD BOLT	3	62	5110-251 CYLINDER CONNECTING ROD	1
10	73007 1/4 FLAT WASHER	3	63	5110-267 CYLINDER LINE HOSES	1
11	73008 1/4-20 NYLON LOCK NUT	4	64	5110-268 STRAIGHT VALVE FITTING	2
12	73014 1/4-20 X 1-1/2 HEXHEAD BOLT	1	65	5110-271 LEVER BRACKET	1
13	73020 1/4-20 X 5/8 WIZLOCK BOLT	3	66	5110-272 CYLINDER LIFT LEVER ONLY	1
14	73025 1/4 BUTTON HEAD RIVET	1	67	5110-404 REAR WEIGHT	1
15	73201 3/8-16 X 1 HEXHEAD CAP SCREW, GR. 5	2	68	5110-405 18" WHEEL RIM & TIRE	2
16	73202 3/8 INTERNAL LOCK WASHER	6	69	5200-116 BACK-UP BEEPER ASSEMBLY	1
17	73203 3/8 SAE FLAT WASHER	2	70	5200-118-1 ELECTRICAL BOX SHELL ONLY	1
18	73204 3/8 SPLIT LOCK WASHER	2	71	5200-118-8 BLUE 48V BATTERY CHARGER CONNEC TOR	3
19	73207 3/8-16 NYLON LOCK NUT	2	72	5200-118-9 48V BATTERY CONNECTOR	2
20	73208 3/8-16 X 1 1/2 HEXHEAD CAP SCREW	2	73	5200-127 ELECTRICAL STRIP	1
21	73213 3/8-16 X 3/4 BUTTON HEAD CAP SCREW	3	74	5200-157 DRAIN/FILLER PLUG	3
22	73214 3/8-16 X 1 BUTTON HEAD SOCKET CAP SCREW	2	75	5200-18 CLAMP FRONT MOTOR	2
23	73227 3/8-24 X 1 SET SCREW	3	76	5200-194 DOUBLE WHEEL CASTER ASSEMBLY	1
24	73235 3/8-24 JAMB NUT	3	77	5200-194A REPLACEMENT WHEEL ONLY	2
25	73270 3/8 X 3 LOCK PIN	1	78	5200-1G DOUBLE PUMP GASKET	1
26	73320 5/16-18 X 2 SOCKET HEAD CAP SCREW	1	79	5200-261 WHEEL MOTOR LINE	4
27	73321 5/16-18 X 3 1/2 SOCKET HEAD CAP SCREW	1	80	5200-266 RETURN LINE	2
28	73322 5/16-18 NYLON LOCK NUT	3	81	5200-28 SIDE SUPPORT ROD	2
29	73333 5/16-18 X 1 1/2 SOCKET HEAD CAP SCREW	3	82	5200-30-SV BASE ASSEMBLY	1
30	73402 1/2-13 NYLON LOCK NUT	4	83	5200-603 HOSE GUIDE	1
31	73406 1/2-13 X 1-1/4 HEXHEAD BOLT	1	84	5200-604 FILTER BLOCK	1
32	73410 1/2-13 X 3 1/2 HEXHEAD CAP SCREW	1	85	5200QL-11-LH SINGLE SPOOL VALVE	1
33	73427 1/2 - 13 X 1-1/2 HEXHEAD CAP SCREW	4	86	5200QL-11-RH DOUBLE SPOOL VALVE	1
34	73536 CYLINDER CLIP	2	87	5200QL-13 VALVE LEVER SPACER	1
35	74425 10/32 K-LOCK NUT	2	88	5200QL-14 BACKUP BEEPER PIN ASSEMBLY	1
36	74513 6-32 X 3/4 PHILLIPS PANHEAD MACHINE SCREW	2	89	5200QL-1A MOTOR PLATE	1
37	400133 HIGH SPEED HYDRAULIC WHEEL MOTOR	2	90	5200QL-25-SV RIGHT SIDE PANEL	1
38	400327 HANDLE RUBBER COVER	2	91	5200QL-26-SV LEFT SIDE PANEL (NOT SHOWN)	1
39	401429 LOWER CUTTING HEAD SUPPORT PIN	1	92	5200QL-27 MAIN BASE (NOT SHOWN)	1
40	401553 BATTERY CHARGER - ON BOARD 48V 115V	1	93	5200QL-28-SV BATTERY HINGED COVER	1
41	401567 SLIDE PLATE	1	94	5200QL-30 HOOD LEVER ASSEMBLY	1
42	401568 LOWER CUTTING HEAD SUPPORT SEAT	1	95	5200QL-31 HOOD LEVER ONLY	1
43	5110-111 WHEEL MOTOR FITTING	4	96	5200QL-32 HOOD LEVER BRACKET ONLY	1
44	5110-114-2 SINGLE SPOOL CONTROL	1	97	5200QL-34 REVERSE CATCH	1
45	5110-115 DOUBLE SPOOL CONTROL	1	98	5200QL-42-SV COVER, HINGED TOP, SILVER VEIN	1
46	5110-116 WHEEL HUB	2	99	5213-2 8 VOLT BATTERY, 180 AH	6
47	5110-164A RETURN TANK HOSE	1	100	5600-21 HANDLE WELDMENT, LEFT	1
48	5110-164B RETURN TANK HOSE CLAMP	1	101	5600-22 HANDLE WELDMENT, RIGHT	1
49	5110-170 CUTTING HEAD PIN	1	102	5600-58 VALVE LEVER - SHORT	1
50	5110-180 FOOT PEG	2	103	5700-102 E-STOP SWITCH ASSEMBLY	1
51	5110-207 SEAT SWITCH (NOT SHOWN)	1	104	5700-103 SWITCH, START, ASSEMBLY	1
52	5110-218 BACK-UP BEEPER SWITCH	1	105	5700-104 BATTERY FUEL GAUGE	1
			106	5700-106 70 AMP CIRCUIT BREAKER	1
			107	5700-36 HOSE GUARD	2
			108	5700-52 90° VALVE FITTING	2

# Complete Parts List

PART#	DESCRIPTION	QTY	PART#	DESCRIPTION	QTY
109	5700-54 HANDLE GRIP SLEEVE	2	127	L106 PINCH POINT LABEL	2
110	5700-62 COVER, BATTERY HOLD DOWN	3	128	L118 OPERATOR MUST BE SEATED LABEL	1
111	5700-64 FILTER FITTING	2	129	L137 WARNING DISARM MACHINE LABEL	2
112	5700-65 FILTER	1	130	L142 TRAILER HITCH LABEL	1
113	5700-66 HEAD	1	131	L148 GENERAL INFO LABEL	1
114	5700-67 TANK PLUG	2	132	L155 GENERAL WARNING LABEL	1
115	5700-70 T-FITTING	1	133	L162 48 VOLT VDC LABEL	1
116	5700-71 HOSE (RETURN, RIGHT)	1	134	L165 LARGE RIDE-ON LABEL W/ BLADE INFO	1
117	5700-72 HOSE (RETURN, LEFT)	1	135	L176 NATIONAL LABEL, LARGE	2
118	5700-75 HOSE (PRESSURE, LEFT-12.5)	1	136	L304 METAL SERIAL NUMBER PLATE	1
119	5700-76 HOSE (PRESSURE, RIGHT-25)	1	137	L307 2900 STOCK NUMBER LABEL	1
120	5700-77 SUCTION HOSE ASSEMBLY	2	138	L33B CAUTION MOVING PARTS LABEL	2
121	5700-81 SUCTION LINE	1	139	L33C INSTRUCTION MANUAL LABEL	1
122	5700-90 RELAY SOCKETS	1	140	L33D AUTHORIZED PERSONNEL ONLY LABEL	1
123	5700-91 SPECIALTY VOLTAGE RELAYS	1	141	L37 CAUTION SHARP BLADES LABEL	2
124	6280-162G TANK MAGNET (NOT SHOWN)	1	142	L38 DISCONNECT BEFORE SERVICING LABEL	1
125	70905-D5 HYDRAULIC DOUBLE PUMP #5	1	143	L66 LARGE CAUTION LABEL	1
126	L08-1 STAND CLEAR LABEL	2	144	L95F FLUID LEAK LABEL	2

# Parts List and Diagrams

## EXTERNAL PARTS

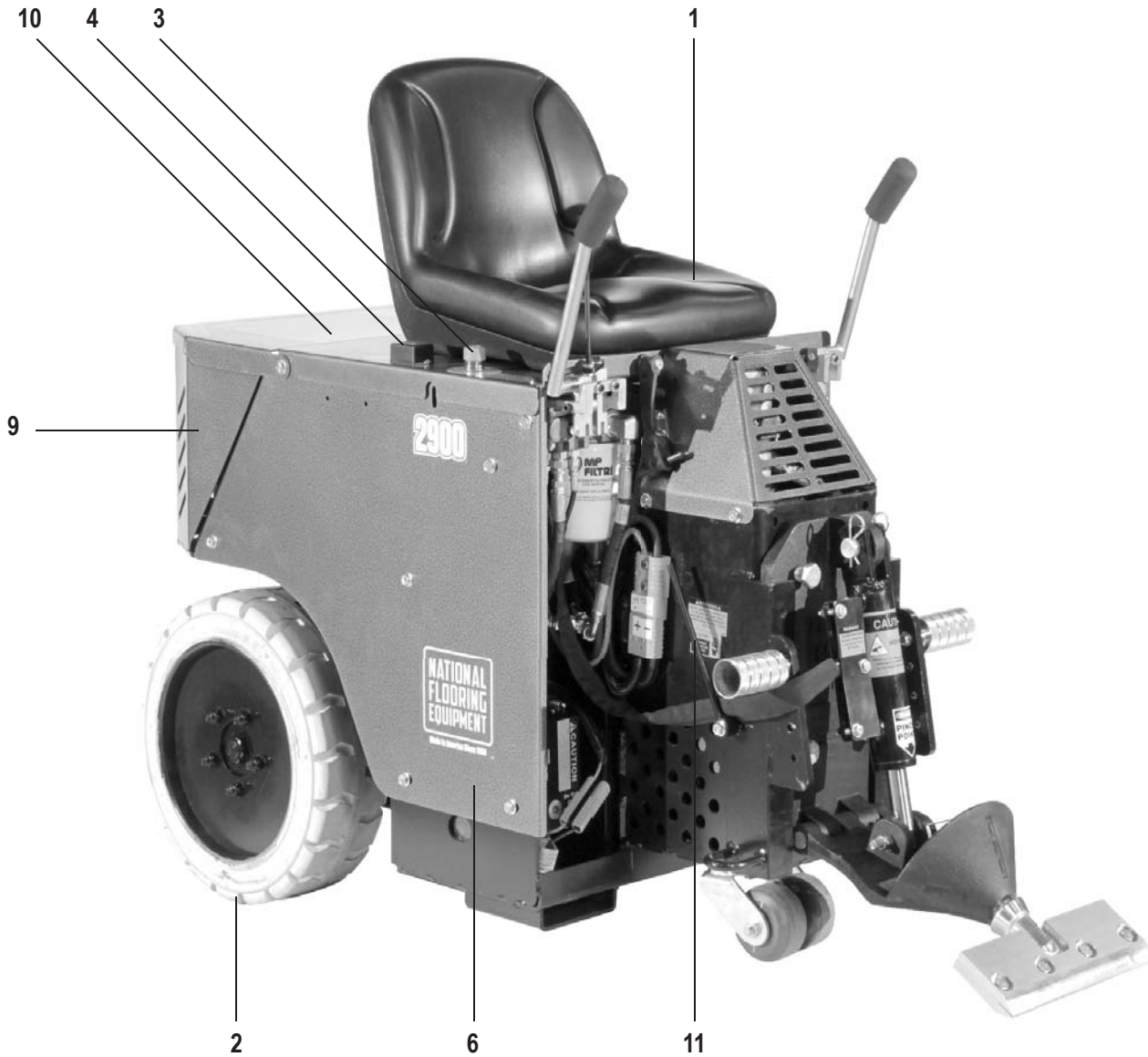

PART#	DESCRIPTION	QTY	PART#	DESCRIPTION	QTY
1	5110-111 SEAT	1	8	5200QL-27 MAIN BASE (NOT SHOWN)	1
2	5110-405 18" WHEEL RIM & TIRE	2	9	5200QL-28-SV BATTERY HINGED COVER	1
3	5700-102 E-STOP SWITCH ASSEMBLY	1	10	5200QL-42-SV COVER, HINGED TOP, SILVER VEIN	1
4	5700-105 BATTERY FUEL GAUGE	1	11	5200-603 HOSE GUIDE	1
5	5110-207 SEAT SWITCH (NOT SHOWN)	1	12	5700-103 SWITCH, START, ASSEMBLY (NOT SHOWN)	1
6	5200QL-25-SV RIGHT SIDE PANEL	1			
7	5200QL-26-SV LEFT SIDE PANEL (NOT SHOWN)	1			

# Parts List and Diagrams

PART#	DESCRIPTION	QTY	
1	401567	SLIDE PLATE	1
2	401568	LOWER CUTTING HEAD SUPPORT	1
3	5110-180	FOOT PEG	2
4	5110-250	CYLINDER	1
5	5200-30-SV	BASE ASSEMBLY	1
6	5200-194	DOUBLE WHEEL CASTER ASSEMBLY	1
7	401553	BATTERY CHARGER - ON BOARD 48V 115V	1
8	73270	3/8 X 3 LOCK PIN	1
9	401429	LOWER CUTTING HEAD SUPPORT PIN	1

## EXTERNAL PARTS

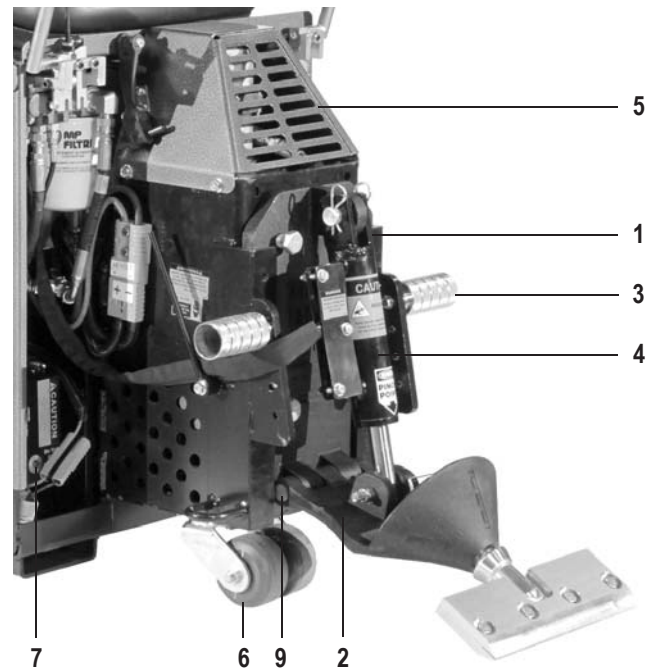

PART#	DESCRIPTION	QTY	
1	5200QL-30	HOOD LEVER ASSEMBLY	1
2	5200QL-31	HOOD LEVER ONLY	1
3	5200QL-32	HOOD LEVER BRACKET ONLY	1
4	5200QL-34	REVERSE CATCH	1
5	73005	1/4-20 X 1/2 HEXHEAD BOLT	3
6	73007	1/4 FLAT WASHER	3
7	73008	1/4-20 NYLON LOCK NUT	4
8	73014	1/4-20 X 1-1/2 HEXHEAD BOLT	1
9	73025	1/4 BUTTON HEAD RIVET	1

## HOOD LEVER PARTS

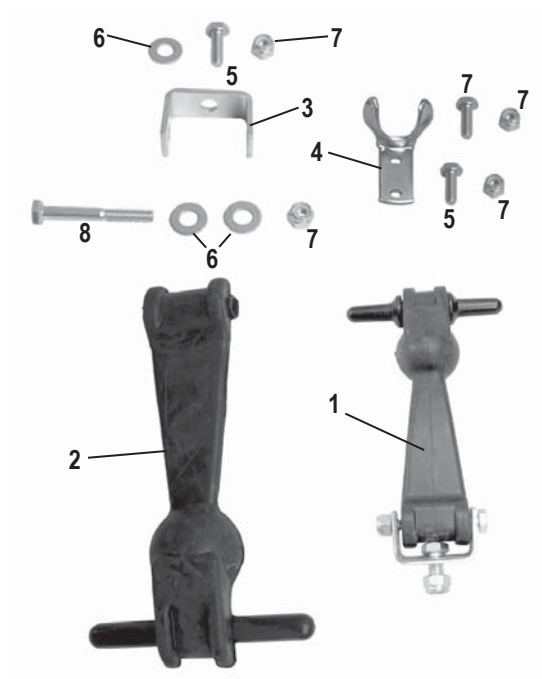

# Parts List and Diagrams

## BACKUP BEEPER ASSEMBLY

	PART#	DESCRIPTION	QTY
1	5200-116	BACK-UP BEEPER ASSEMBLY	1



## HANDLE SWITCH (FOR BEEPER)

	PART#	DESCRIPTION	QTY
1	5110-218	BACK-UP BEEPER SWITCH	1
2	74513	6-32 X 3/4 PHILLIPS PANHEAD MACHINE SCREW	2

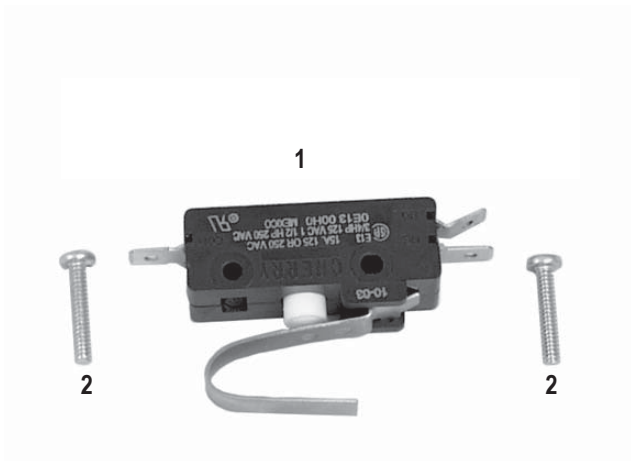

## INSTRUCTION TUBE PARTS

	PART#	DESCRIPTION	QTY
1	70602	INSTRUCTION MANUAL TUBE	1
2	70603	INSTRUCTION TUBE CAP	1
3	74425	10/32 K-LOCK NUT	2

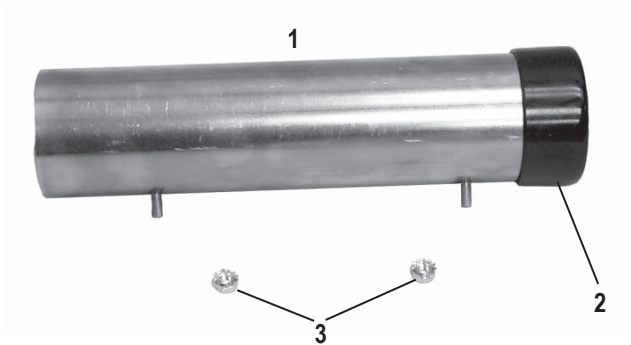

# Parts List and Diagrams

## ELECTRIC BOX & BATTERY CONNECTOR PARTS

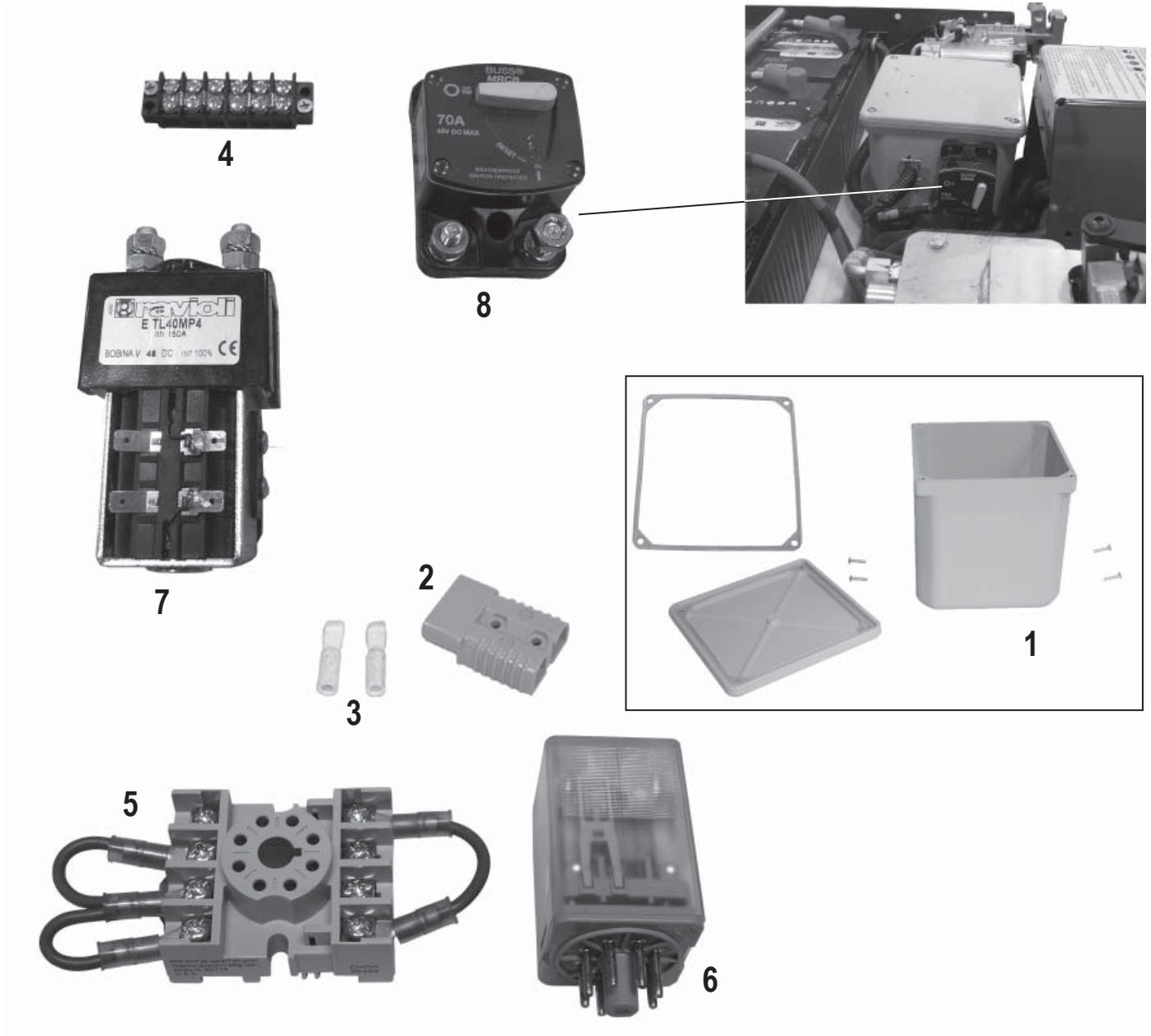

PART#	DESCRIPTION	QTY	PART#	DESCRIPTION	QTY
1	5200-118-1 ELECTRICAL BOX SHELL ONLY	1	5	5700-90 RELAY SOCKETS	1
2	5200-118-8 BLUE 48V BATTERY CHARGER CONNECTOR	3	6	5700-91 SPECIALTY VOLTAGE RELAYS	1
3	5200-118-9 48V BATTERY CONNECTOR	2	7	5700-104 CONTACTOR	1
4	5200-127 ELECTRICAL STRIP	1	8	5700-106 70 AMP CIRCUIT BREAKER	1

# Parts List and Diagrams

## MOTOR PARTS

2

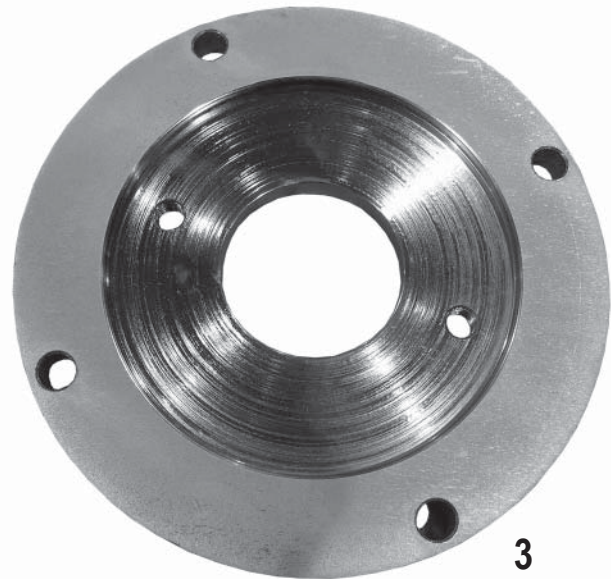
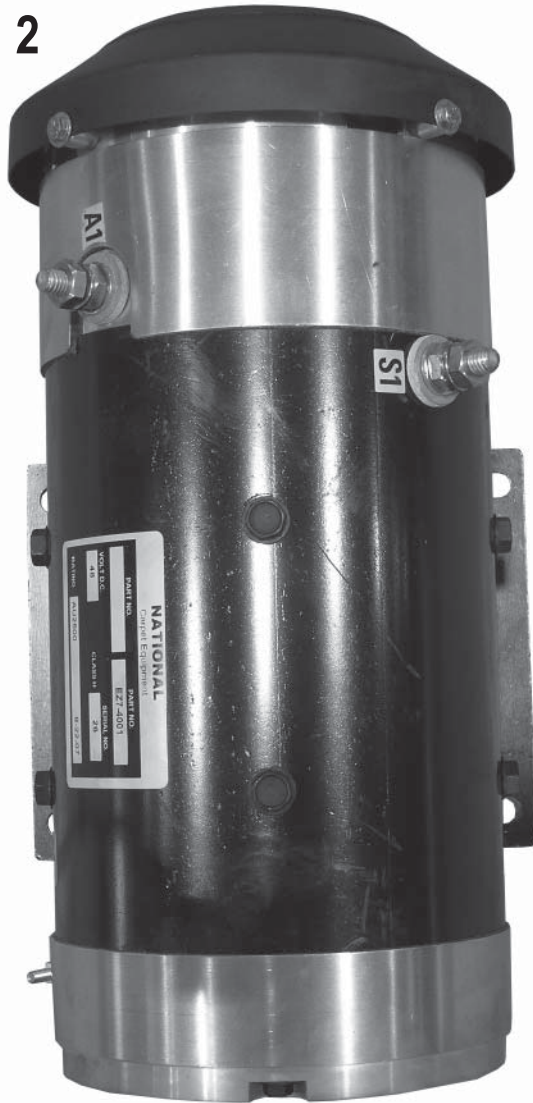

PART#	DESCRIPTION	QTY	PART#	DESCRIPTION	QTY	
1	5200-18	2	4	73201	3/8-16 X 1 HEXHEAD CAP SCREW, GR. 5	2
2	72385	1	5	73204	3/8 SPLIT LOCK WASHER	2
3	5200QL-1A	1				



# Parts List and Diagrams

## PUMP PARTS

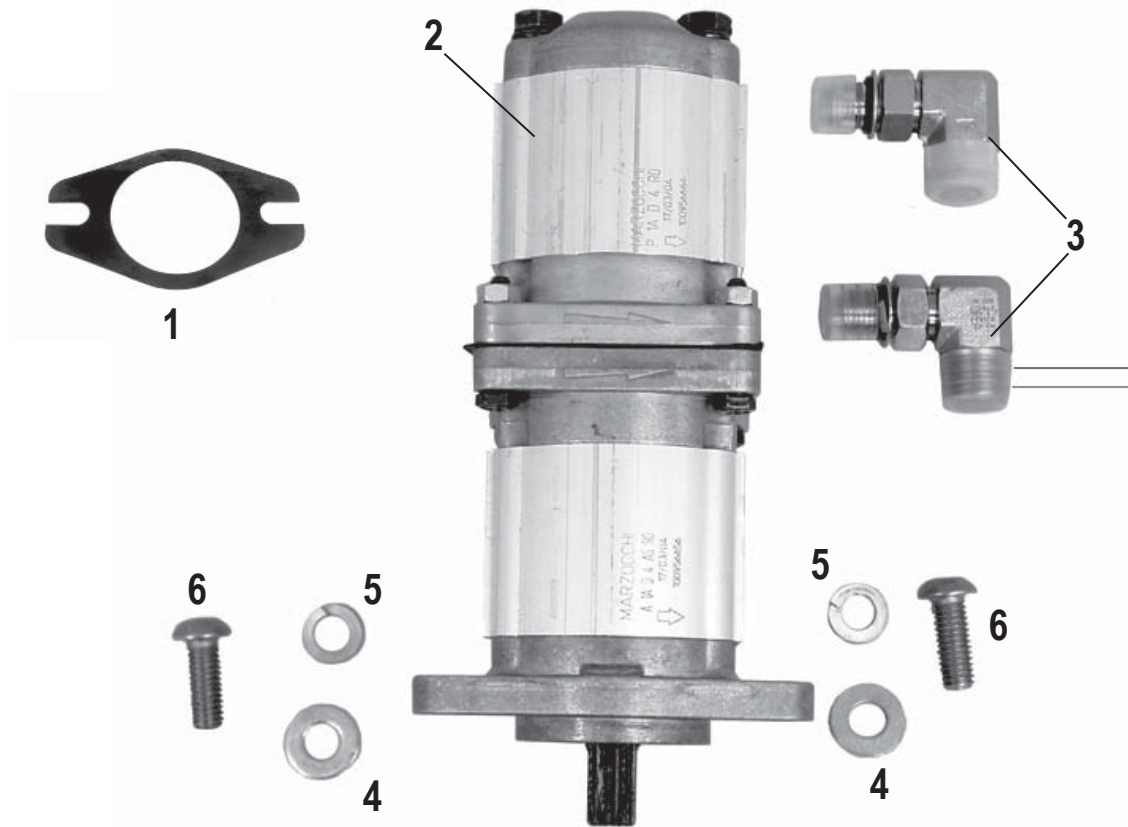

PART#	DESCRIPTION	QTY	PART#	DESCRIPTION	QTY		
1	5200-1G	DOUBLE PUMP GASKET	1	5	73204	3/8 SPLIT LOCK WASHER	2
2	70905-D5	MARZOCCHI DOUBLE PUMP #5	1	6	73214	3/8-16 X 1 BUTTON HEAD SOCKET CAP SCREW	2
3	72816	3/8 " 90° PUMP FITTING	2				
4	73203	3/8 SAE FLAT WASHER	2				

# Parts List and Diagrams

## WHEEL MOTOR PARTS

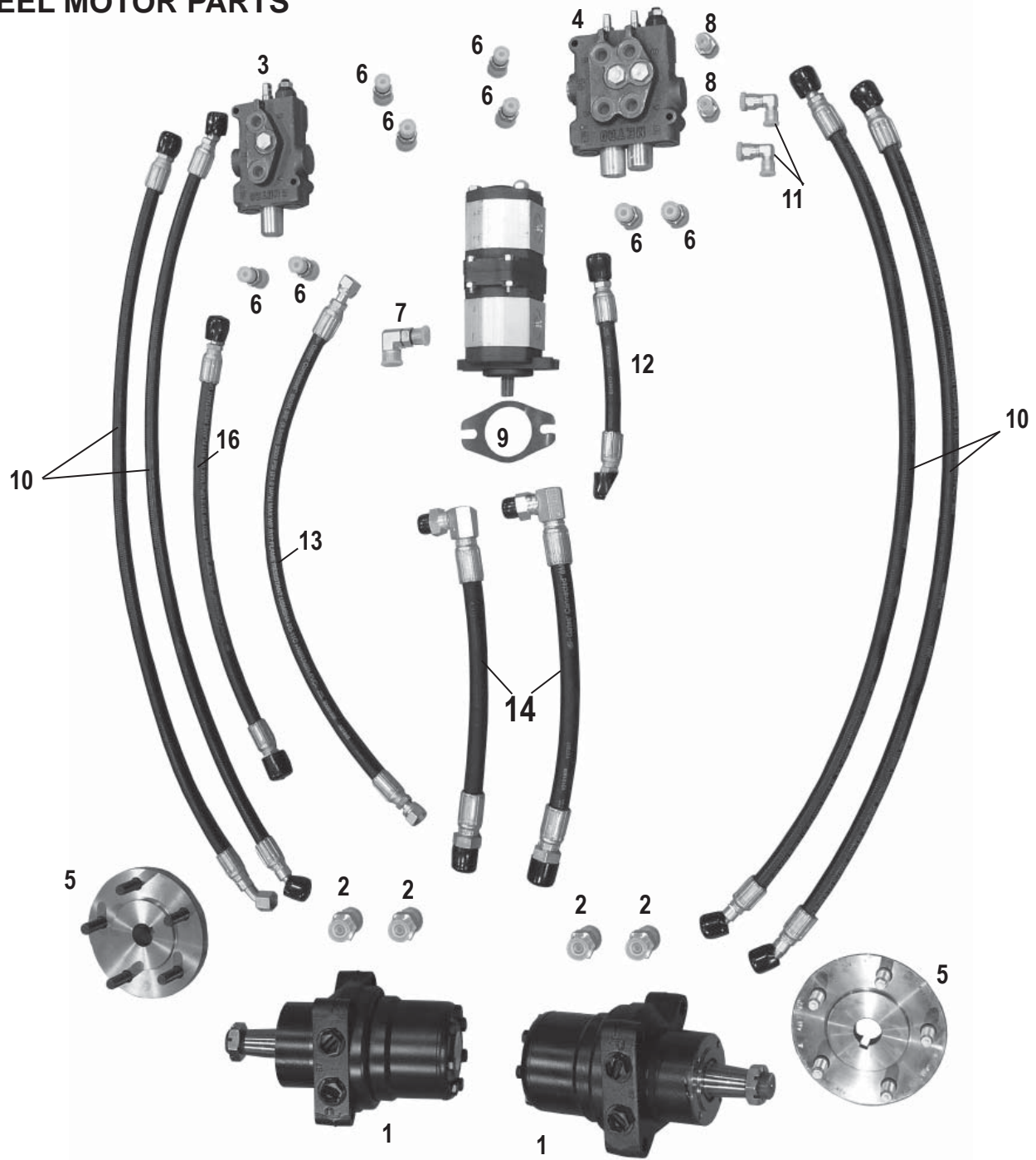

PART#	DESCRIPTION	QTY	PART#	DESCRIPTION	QTY
1	400133 HIGH SPEED HYDRAULIC WHEEL MOTOR	2	10	5200-261 WHEEL MOTOR LINE	4
2	5110-114-2 WHEEL MOTOR FITTING	4	11	5700-52 90° VALVE FITTING	2
3	5110-115 SINGLE SPOOL CONTROL	1	12	5700-71 HOSE (RETURN, RIGHT)	1
4	5110-116 DOUBLE SPOOL CONTROL	1	13	5700-72 HOSE (RETURN, LEFT)	2
5	5110-117 WHEEL HUB	2	14	5700-77 SUCTION HOSE ASSEMBLY	2
6	5110-219 STRAIGHT VALVE BODY PLUG	8	15	5700-81 SUCTION LINE	1
7	72816 FITTING, ELBOW, 90 DEGREE, 3/8"	2	16	70905-D5 HYDRAULIC DOUBLE PUMP #5	1
8	5110-268 STRAIGHT VALVE FITTING	2			
9	5200-1G DOUBLE PUMP GASKET	1			

# Parts List and Diagrams

## FILTER PARTS

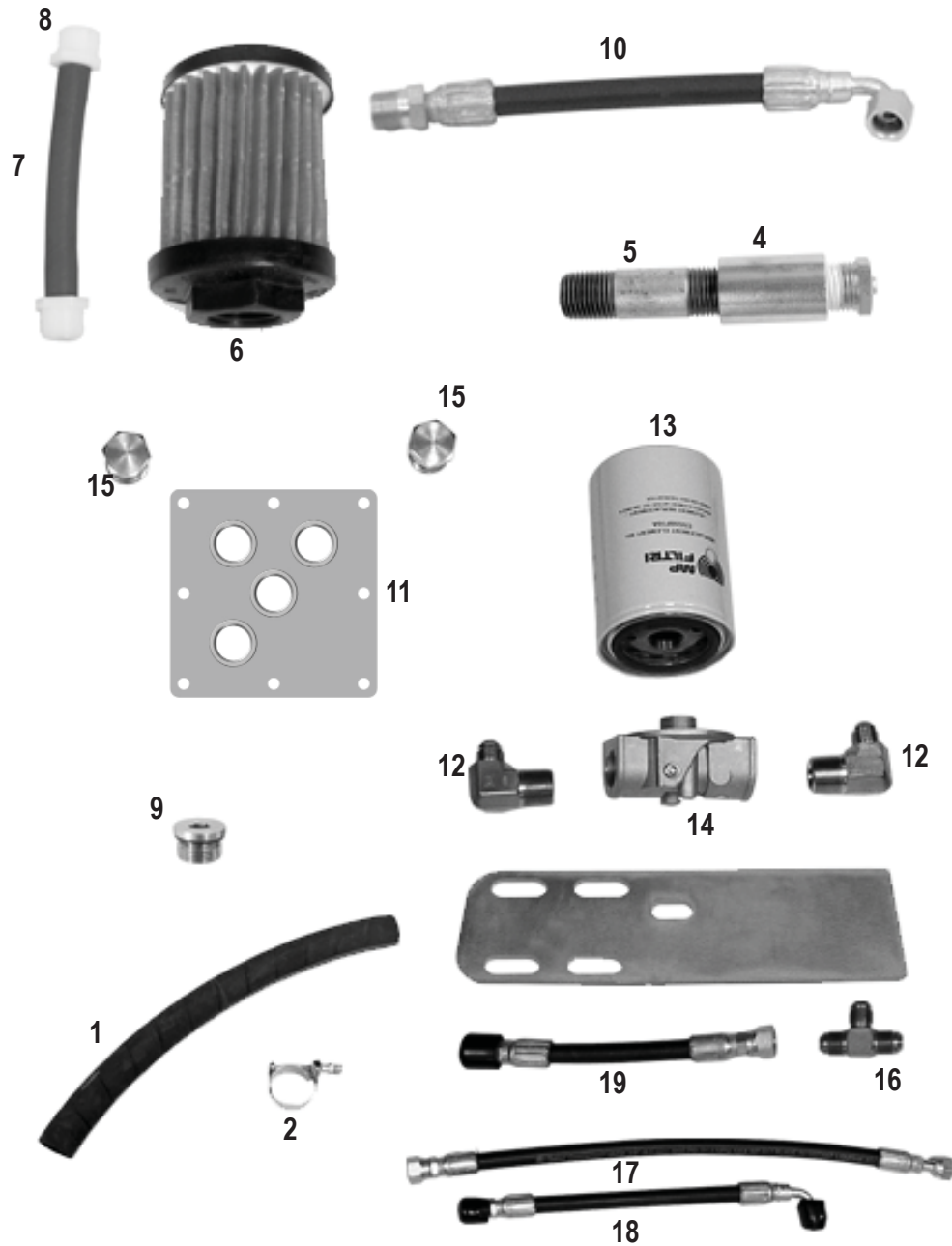

PART#	DESCRIPTION	QTY	PART#	DESCRIPTION	QTY
1	5110-164A RETURN TANK HOSE	1	12	5700-64 FILTER FITTING	2
2	5110-164B RETURN TANK HOSE CLAMP	1	13	5700-65 FILTER	1
3	5110-233 BREATHER ASSEMBLY	1	14	5700-66 HEAD	1
4	5110-234 RELIEF VALVE COUPLER (ONLY)	1	15	5700-67 TANK PLUG	2
5	5110-234-1 RELIEF VALVE NIPPLE (ONLY)	1	16	5700-70 T-FITTING	1
6	5110-237 SUCTION FILTER SCREEN	1	17	5700-72 HOSE (RETURN, LEFT)	1
7	5110-237-1 FILTER SUCTION LINE ASSEMBLY	2	18	5700-75 HOSE (PRESSURE, LEFT-12.5)	1
8	5110-237-1B SUCTION HOSE FITTING(ONLY)	4	19	5700-76 HOSE (PRESSURE, RIGHT-25)	1
9	5200-157 DRAIN/FILLER PLUG	3	20	6280-162G TANK MAGNET (NOT SHOWN)	1
10	5200-266 RETURN LINE	2	21	70612 BRACKET	1
11	5200-604 FILTER BLOCK	1			

# Parts List and Diagrams

## CONTROL LEVER PARTS

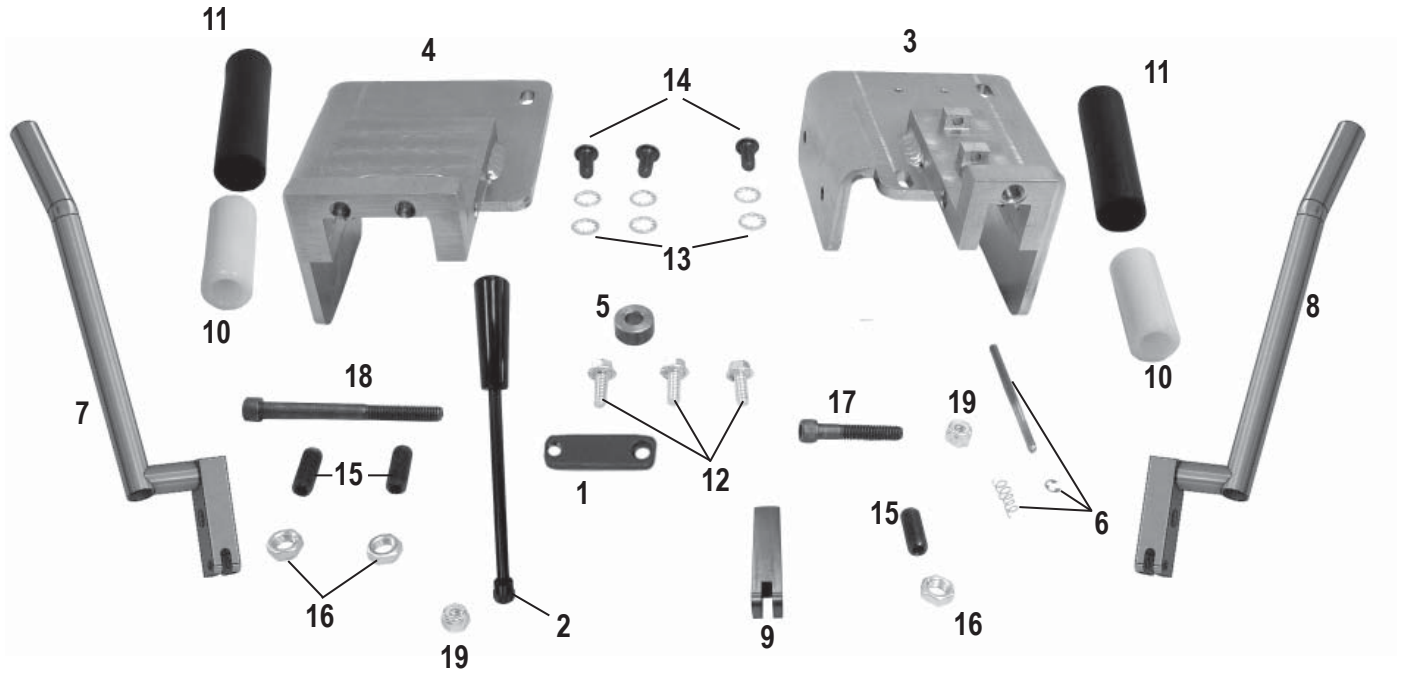

PART#	DESCRIPTION	QTY	PART#	DESCRIPTION	QTY
1	5110-271 LEVER BRACKET	1	11	400327 HANDLE RUBBER COVER	2
2	5110-272 CYLINDER LIFT LEVER ONLY	1	12	73020 1/4-20 X 5/8 WIZLOCK BOLT	3
3	5200QL-11-LH SINGLE SPOOL VALVE	1	13	73202 3/8 INTERNAL LOCK WASHER	6
4	5200QL-11-RH DOUBLE SPOOL VALVE	1	14	73213 3/8-16 X 3/4 BUTTON HEAD CAP SCREW	3
5	5200QL-13 VALVE LEVER SPACER	1	15	73227 3/8-24 X 1 SET SCREW	3
6	5200QL-14 BACKUP BEEPER PIN ASSEMBLY	1	16	73235 3/8-24 JAMB NUT	3
7	5600-21 HANDLE WELDMENT, LEFT	1	17	73320 5/16-18 X 2 SOCKET HEAD CAP SCREW	1
8	5600-22 HANDLE WELDMENT, RIGHT	1	18	73321 5/16-18 X 3½ SOCKET HEAD CAP SCREW	1
9	5600-58 VALVE LEVER - SHORT	1	19	73322 5/16 NYLON LOCK NUT	2
10	5700-54 HANDLE GRIP SLEEVE	2			

# Parts List and Diagrams

PART#	DESCRIPTION	QTY
1	5110-267 CYLINDER LINE HOSES	1
2	5110-250 CYLINDER	1
3	5110-251 CYLINDER CONNECTING ROD	1
4	73536 CYLINDER CLIP	2
5	72801 1/4" 90° FITTING	2
6	73402 1/2-13 NYLON LOCK NUT	1
7	73410 1/2-13 X 3 1/2 HEXHEAD CAP SCREW	1

## CYLINDER

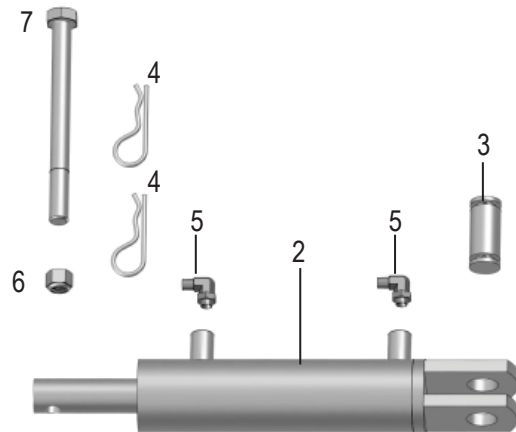

PART#	DESCRIPTION	QTY
1	5700-36 HOSE GUARD	2
2	73322 5/16-18 NYLON LOCK NUT	3
3	73333 5/16-18 X 1 1/2 SOCKET HEAD CAP SCREW	3

## CYLINDER HOSE GUARD

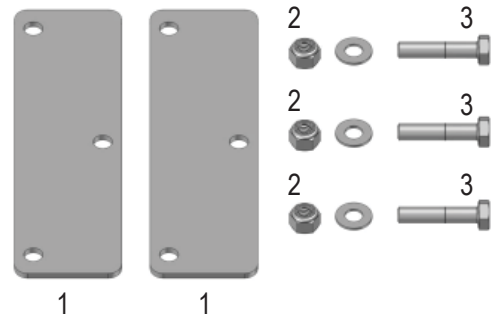

# Parts List and Diagrams

## SLIDE PLATE

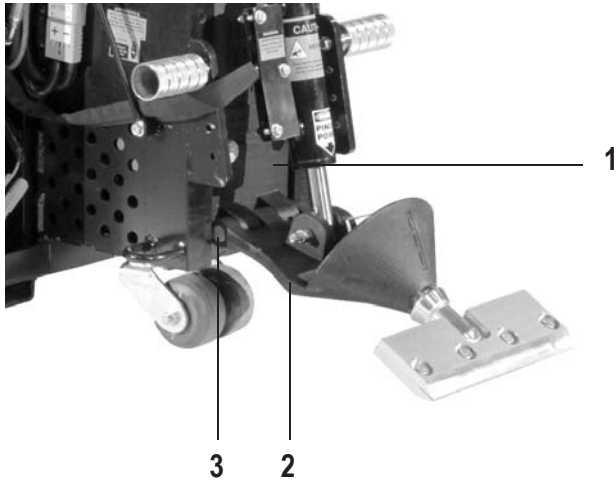

	PART#	DESCRIPTION	QTY
1	401567	SLIDE PLATE	1
2	401568	LOWER CUTTING HEAD SUPPORT	1
3	401429	CUTTING HEAD PIN	1
4	401876	SCREW, SET 3/8-24X1/4 (NOT SHOWN)	1

## CASTER

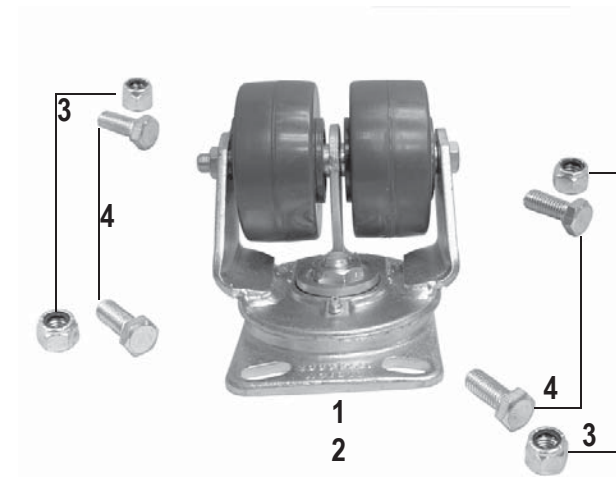

	PART#	DESCRIPTION	QTY
1	5200-194	DOUBLE WHEEL CASTER ASSEMBLY	1
2	5200-194A	REPLACEMENT WHEEL ONLY	2
3	73402	1/2-13 NYLON LOCK NUT	4
4	73427	1/2 - 13 X 1-1/2 HEXHEAD CAP SCREW	4

## FOOT PEG

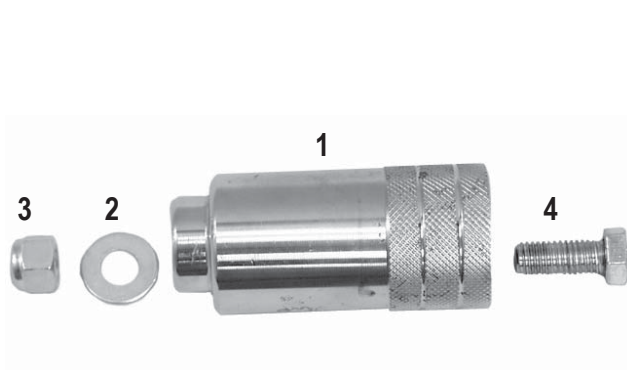

	PART#	DESCRIPTION	QTY
1	5110-180	FOOT PEG	2
2	73204	3/8 SPLIT LOCK WASHER	2
3	73207	3/8-16 NYLON LOCK NUT	2
4	73208	3/8-16 X 1 1/2 HEXHEAD CAP SCREW	2

# Parts List and Diagrams

PART#	DESCRIPTION	QTY
1 5110-404	REAR WEIGHT	1
2 73406	1/2-13 X 1-1/4 HEXHEAD BOLT	1

## WEIGHTS



PART#	DESCRIPTION	QTY
1 5200-28	SIDE SUPPORT ROD	2
2 5213-2	8 VOLT BATTERY, 180 AH	6
3 5700-62	COVER, BATTERY HOLD DOWN	3

## BATTERIES



PART#	DESCRIPTION	QTY
1 401553	ON BOARD CHARGER, 48V 115 V	1
2 72705	50 AMP 48 VOLT CHARGER CONNECTOR ONLY	1

## CHARGER

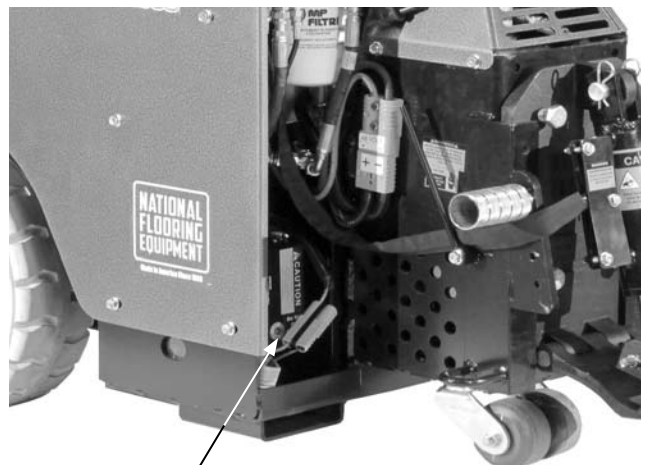

# Parts List and Diagrams

## LABELS

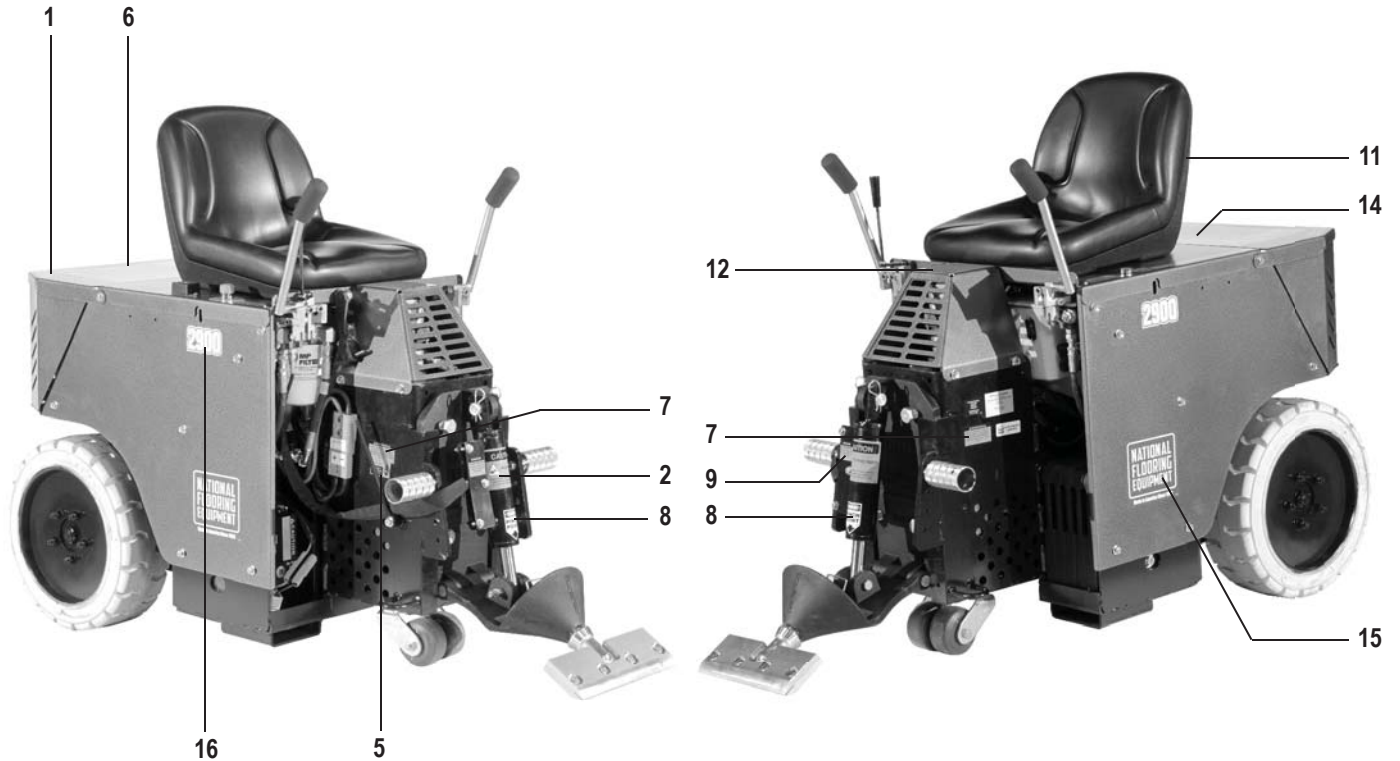

PART#	DESCRIPTION	QTY	PART#	DESCRIPTION	QTY
1	L08-1	2	10	L142	1
2	L33B	2	11	L148	1
3	L33C	1	12	L155	1
4	L37	2	13	L162	1
5	L38	1	14	L165	1
6	L66	1	15	402001	2
7	L95F	2	16	402015	2
8	L106	2			
9	L137	1			



# Parts List and Diagrams

PART#	DESCRIPTION	QTY
1 L33C	INSTRUCTION MANUAL LABEL	1
2 L162	48 VOLT VDC LABEL	1
3 L148	GENERAL INFO LABEL	1

## LABELS (CONT'D)

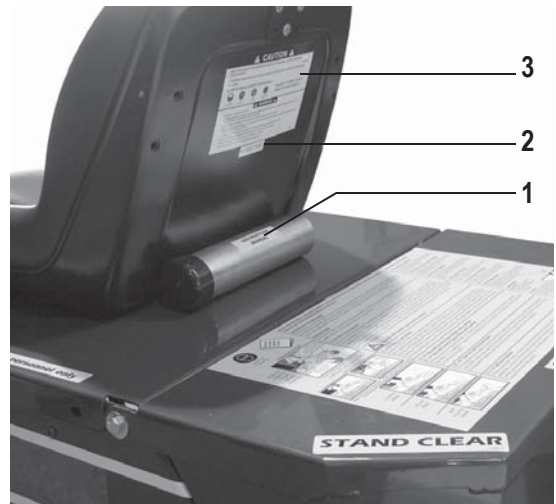

PART#	DESCRIPTION	QTY
1 L33D	AUTHORIZED PERSONNEL ONLY LABEL	1
2 L118	OPERATOR MUST BE SEATED LABEL	1
3 L137	WARNING DISARM MACHINE LABEL	2
4 L304	METAL SERIAL NUMBER PLATE	1
5 402015	2900 STOCK NUMBER LABEL	1

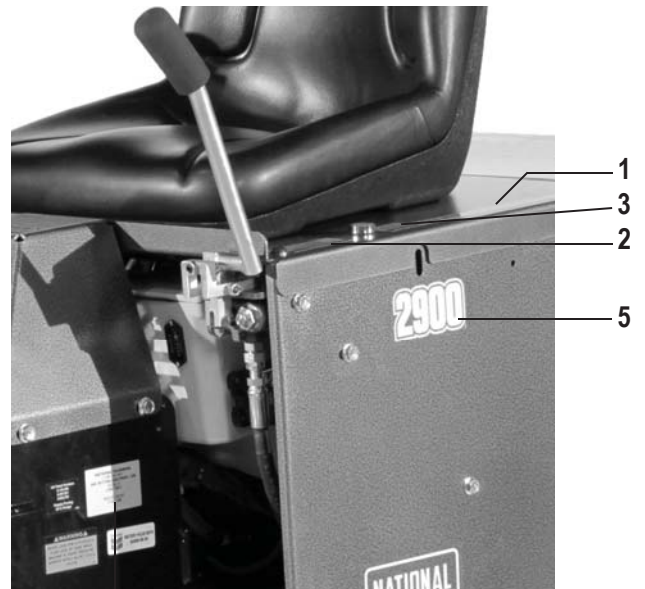

4

# Parts List and Diagrams

---

## TILE BOX

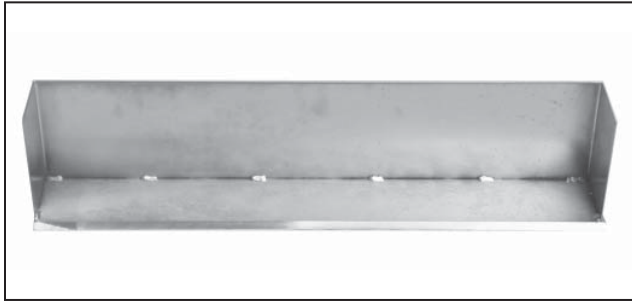

7074 Tile Box

The Tile Box works for wind rowing and assists for a fast clean-up and collection of tile debris for quick removal. High abrasion alloy for a long lasting edge. Resharpens just like a blade. 5" x 27" x 6" box. Attaches to the #7050-27 Cutting Head (required).

## FRONT WHEEL ASSEMBLY

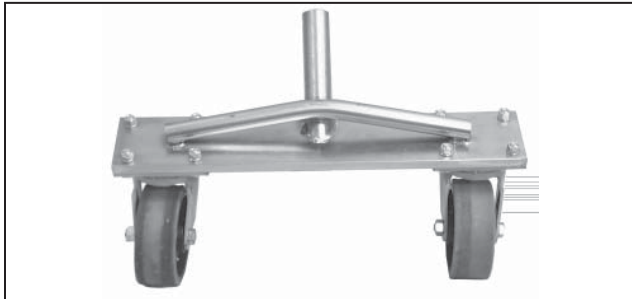

5110-100 Front Wheel Assembly

Allows stability and safe transportation over any surface. Easy and quick to attach.

## CUTTING HEAD EXTENSION

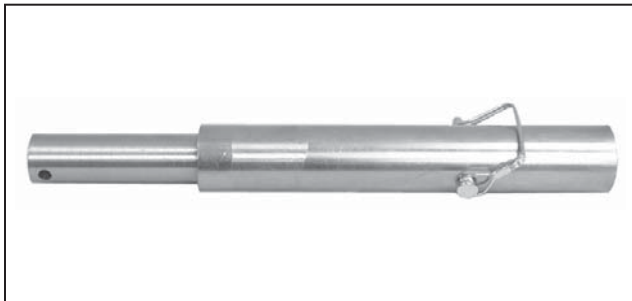

7050-15 Cutting Head Extension

Extension for cutting heads to reach under tight areas.

## OPTIONAL ARM RESTS



5110-111-3 Optional Arm Rests

Optional Arm Rests for added comfort. Set includes left and right arm rest and mounting hardware.

## SAFETY GLASSES



1009 Safety Glasses

Large frame, flat fold side shields, clear lenses, and ANSI certified safety glasses.

# Parts List and Diagrams

## CONTROL BOX WIRING DIAGRAM

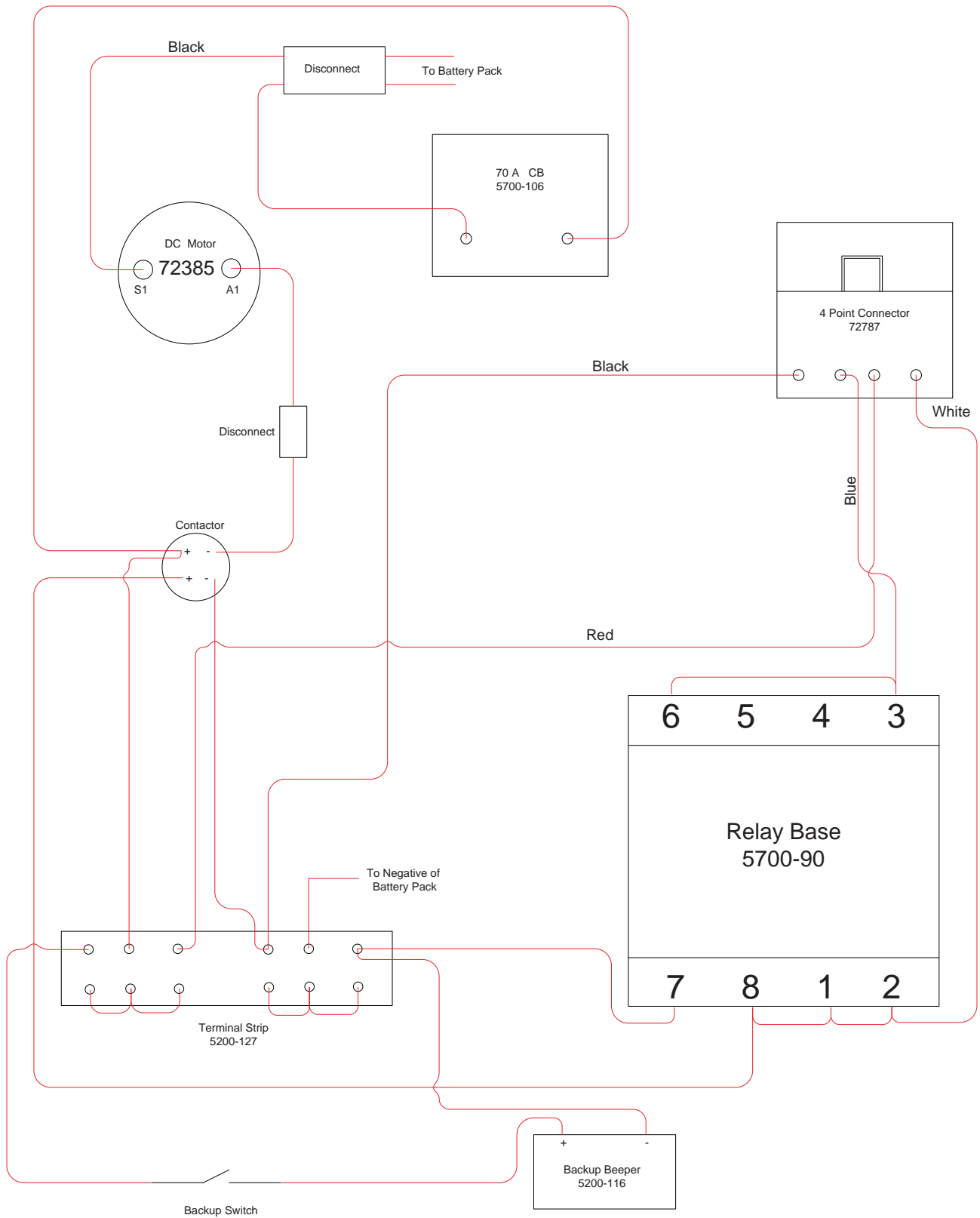

# Parts List and Diagrams

## SEAT WIRING DIAGRAM

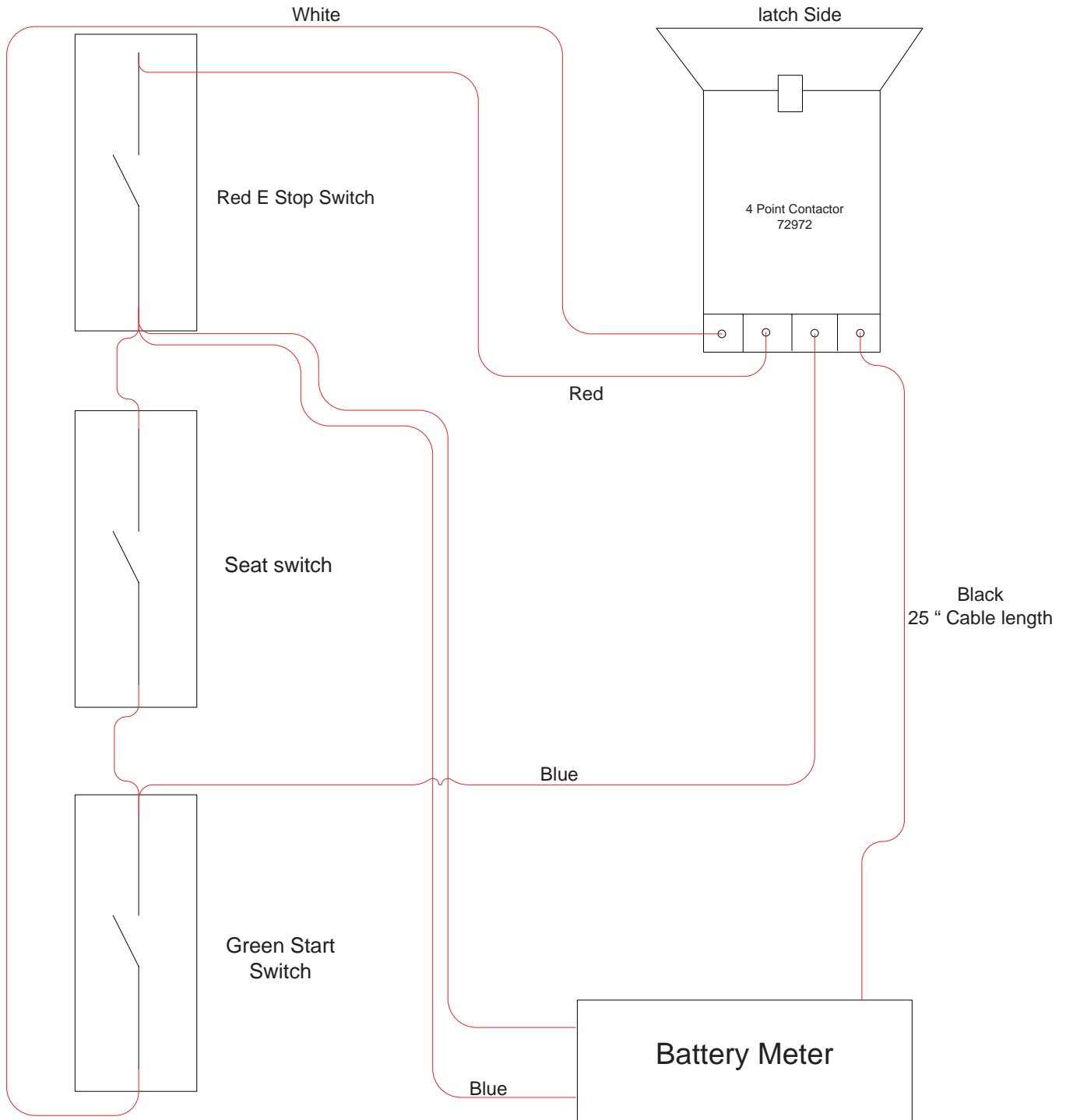

# Parts List and Diagrams

## BATTERY WIRING DIAGRAM

Rear of Machine

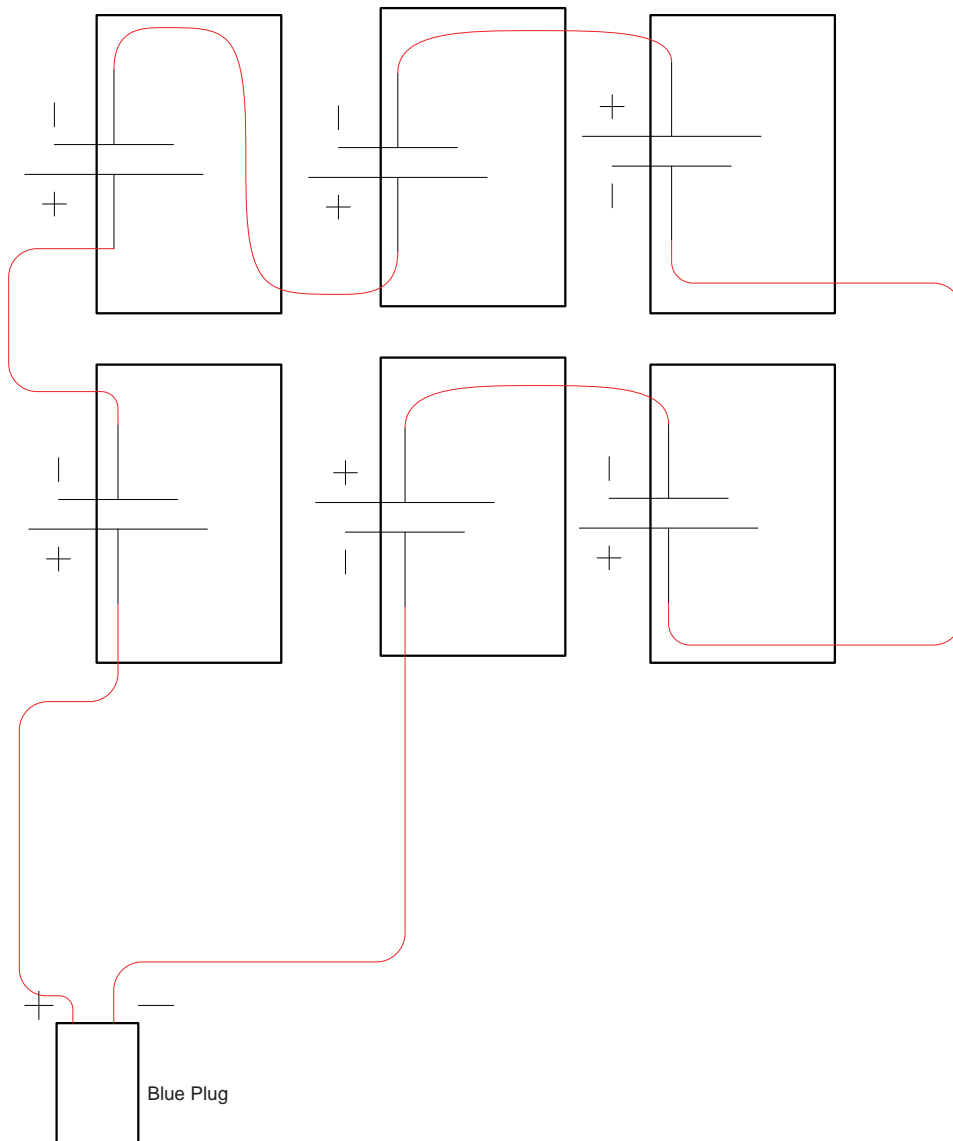

# Material Safety Data Sheet (MSDS) Information

## CHEVRON HD 22 - 68 - HYDRAULIC FLUID

### PRODUCT IDENTIFICATION AND COMPANY IDENTIFICATION

Product Number(S): CPS221655, CPS221658, CPS221659

Synonyms: Texaco Rando HD22, Texaco Rando HD 32, Texaco Rando HD 46, Texaco Rando HD 68

Company Information

Chevron Products Company

a division of Chevron U.S.A. Inc.

6001 Bollinger Canyon Road

San Ramon, CA 94583

United States of America

www.chevronlubricants.com

Transportation Emergency Response

CHEMTREC: (800) 424-9300 or (703) 527-3887

Health Emergency

Chevron Emergency Information Center: Located in the USA.

International collect calls accepted.

(800) 231-0623 or (510) 231-0623

Product Information

email: lubemsds@chevron.com

Product Information: 800-LUBE-TEK

MSDS Requests: 800-414-6737

### HAZARDOUS INGREDIENTS / IDENTIFY INFORMATION

MATERIALS/COMPONENTS	CAS NUMER	AMOUNT
Highly Refined Mineral Oil (C15 - C50)	mixture	90-100% weight

### IMMEDIATE HEALTH EFFECTS

**Eye:** Not expected to cause prolonged or significant eye irritation.

**Skin:** Contact with the skin is not expected to cause prolonged or significant irritation. Not expected to be harmful to internal organs if absorbed through the skin. High-Pressure Equipment Information: Accidental high-velocity injection under the skin of materials of this type may result in serious injury. Seek medical attention at once should an accident like this occur. The initial wound at the injection site may not appear to be serious at first; but, if left untreated, could result in disfigurement or amputation of the affected part.

**Ingestion:** Not expected to be harmful if swallowed.

**Inhalation:** Not expected to be harmful if inhaled. Contains a petroleum-based mineral oil. May cause respiratory irritation or other pulmonary effects following prolonged or repeated inhalation of oil mist at airborne levels above the recommended mineral oil mist exposure limit. Symptoms of respiratory irritation may include coughing and difficulty breathing.

### FIRST AID MEASURES

**Eye:** No specific first aid measures are required. As a precaution, remove contact lenses, if worn, and flush eyes with water.

**Skin:** No specific first aid measures are required. As a precaution, remove clothing and shoes if contaminated. To remove the material from skin, use soap and water. Discard contaminated clothing and shoes or thoroughly clean before reuse.

**Ingestion:** No specific first aid measures are required. Do not induce vomiting. As a precaution, get medical advice.

**Inhalation:** No specific first aid measures are required. If exposed to excessive levels of material in the air, move the exposed person to fresh air. Get medical attention if coughing or respiratory discomfort occurs.

**Note to Physicians:** In an accident involving high-pressure equipment, this product may be injected under the skin. Such an accident may result in a small, sometimes bloodless, puncture wound. However, because of its driving force, material injected into a fingertip can be deposited into the palm of the hand. Within 24 hours, there is usually a great deal of swelling, discoloration, and intense throbbing pain. Immediate treatment at a surgical emergency center is recommended.

### FIRE FIGHTING MEASURES

Leaks/ruptures in high pressure system using materials of this type can create a fire hazard when in the vicinity of ignition sources (eg. open flame, pilot lights, sparks, or electric arcs).

**FIRE CLASSIFICATION:** OSHA Classification (29 CFR 1910.1200): Not classified by OSHA as flammable or combustible.

**NFPA RATINGS:** Health: 0 Flammability: 1 Reactivity: 0

### FLAMMABLE PROPERTIES:

Flashpoint: (Cleveland Open Cup) 150 C (302 F) (Min)

Autoignition: No Data Available

Flammability (Explosive) Limits (% by volume in the air): Lower: Not Applicable Upper: Not Applicable

# Material Safety Data Sheet (MSDS) Information

## CHEVRON HD 22 - 68 - HYDRAULIC FLUID (CONTINUED)

**EXTINGUISHING MEDIA:** Use water fog, foam, dry chemical or carbon dioxide (CO<sub>2</sub>) to extinguish flames.

**PROTECTION OF FIRE FIGHTERS:** Fire Fighting instructions: This material will burn although it is not easily ignited. For fires involving this material, do not enter any enclosed or confined fire space without proper protective equipment, including self-contained breathing apparatus.

**Combustion Products:** Highly dependent on combustion conditions. A complex mixture of airborne solids, liquids, and gases including carbon monoxide, carbon dioxide, and unidentified organic compounds will be evolved when pounds will be evolved when this material undergoes combustion.

### ACCIDENTAL RELEASE MEASURES

**Protective Measures:** Eliminate all sources of ignition in vicinity of spilled material.

**Spill Management:** Stop the source of the release if you can do it without risk. Contain release to prevent further contamination of soil, surface water or groundwater. Clean up spill as soon as possible, observing precautions in Exposure Controls/Personal Protection. Use appropriate techniques such as applying non-combustible absorbent materials or pumping. Where feasible and appropriate, remove contaminated soil. Place contaminated materials in disposable containers and dispose of in a manner consistent with applicable regulations.

**Reporting:** Report spills to local authorities and/or the U.S. Coast Guard's National Response Center at (800) 424-8802 as appropriate or required.

### HANDLING AND STORAGE

**Precautionary Measures:** DO NOT USE IN HIGH PRESSURE SYSTEMS in the vicinity of flames, sparks and hot surfaces. Use only in well ventilated areas. Keep container closed.

**General Handling Information:** Avoid contaminating soil or releasing this material into sewage and drainage systems and bodies of water.

Electrostatic charge may accumulate and create a hazardous condition when handling this material. To minimize this hazard, bonding and grounding may be a necessary but may not, by themselves, be sufficient. Review all operations which have the potential of generating and accumulating an electrostatic charge and/or a flammable atmosphere (including tank and container filling, splash filling, tank cleaning, sampling, gauging, switch loading, filtering, mixing, agitation, and vacuum truck operations) and use appropriate mitigating procedures. For more information, refer to OSHA standard 29 CFR 1910.106, 'Flammable and Combustible Liquids', National Fire Protection Association (NFPA 77, 'Recommended Practice on Static Electricity', and/or the American Petroleum Institute (API) Recommended Practice 2003, 'Protection Against Ignitions Arising Out of Static, Lightning, and Stray Currents'.

**Container Warnings:** Container is not designed to contain pressure. Do not use pressure to empty container or it may rupture with explosive force. Empty containers retain product residue (solid, liquid, and/or vapor) and can be dangerous. Do not pressurize, cut, weld, braze, solder, drill, grind, or expose such containers to heat, flame, sparks, static electricity, or other sources of ignition. They may explode and cause injury or death. Empty containers should be completely drained, properly closed, and promptly returned to a drum reconditioner or disposed of properly.

### EXPOSURE CONTROLS/PERSONAL PROTECTION

**GENERAL CONSIDERATIONS:** Consider the potential hazards of this material (see Section 3), applicable exposure limits, job activities, and other substances in the workplace when designing engineering controls and selecting personal protective equipment. If engineering controls or work practices are not adequate to prevent exposure to harmful levels of this material, the personal protective equipment listed below is recommended. The user should read and understand all instructions and limitations supplied with the equipment since protection is usually provided for a limited time or under certain circumstances.

**ENGINEERING CONTROLS:** Use in a well-ventilated area.

### PERSONAL PROTECTIVE EQUIPMENT

**Eye/Face Protection:** No special eye protection is normally required. Where splashing is possible, wear safety glasses with side shields as a good safety practice.

**Skin Protection:** No special protective clothing is normally required. Where splashing is possible, select protective clothing depending on operations conducted, physical requirements and other substances in the workplace. Suggested materials for protective gloves include: 4H (PE/EVAL), Nitrile Rubber, Silver Shield, Viton.

**Respiratory Protection:** No respiratory protection is normally required. If user operations generate an oil mist, determine if airborne concentrations are below the occupational exposure limit for mineral oil mist. If not, wear an approved respirator that provides adequate protection from measured concentrations of this material. For air-purifying respirators use a particulate cartridge. Use a positive pressure air-supplying respirator in circumstances where air-purifying respirators may not provide adequate protection.

# Chevron HD 22 - 68 - hydraulic fluid (continued)

## CHEVRON HD 22 - 68 - HYDRAULIC FLUID (CONTINUED)

### PHYSICAL AND CHEMICAL PROPERTIES

Attention: The data below are typical values and do not constitute a specification.

**Color:** Yellow

**Physical State:** Liquid

**Odor:** Petroleum odor

**pH:** Not applicable

**Vapor Pressure:** <0.01 mmHg @ 37.8 C (100 F)

**Vapor Density (Air = 1):** >1

**Boiling Point:** >315.6 C (600 F)

**Solubility:** Soluble in hydrocarbons; insoluble in water

**Freezing Point:** Not Applicable

**Melting Point:** Not Applicable

**Specific Gravity:** 0.86 - 0.87 @ 15.6 C (60.1 F) / 15.6 (60.1F)

**Density:** 0.86 kg/l - 0.9 kg/l @ 15 C (59 F)

**Viscosity:** 22 cSt - 61.2 cSt @40 C (104 F) (Min)

### STABILITY AND REACTIVITY

**Chemical Stability:** This material is considered stable under normal ambient and anticipated storage and handling conditions of temperature and pressure.

**Incompatibility With Other Materials:** May react with strong acids or strong oxidizing agents, such as chlorates, nitrates, peroxides, etc.

**Hazardous Decomposition Products:** None known. (None expected)

**Hazardous Polymerization:** Hazardous polymerization will not occur.

### TOXICOLOGICAL INFORMATION

#### IMMEDIATE HEALTH EFFECTS

**Eye Irritation:** The eye irritation hazard is based on evaluation of data for similar materials or product components.

**Skin Irritation:** The skin irritation hazard is based on evaluation of data for similar materials or product components.

**Skin Sensitization:** No product toxicology data available.

**Acute Dermal Toxicity:** The acute dermal toxicity hazard is based on evaluation of data for similar materials or product components.

**Acute Oral Toxicity:** The acute oral toxicity hazard is based on evaluation of data for similar materials or product components.

**Acute Inhalation Toxicity:** The acute inhalation toxicity hazard is based on evaluation of data for similar materials or product components.

#### ADDITIONAL TOXICOLOGY INFORMATION

This product contains petroleum base oils which may be refined by various processes including severe solvent extraction, severe hydrocracking, or severe hydrotreating. None of the oils requires a cancer warning under the OSHA Hazard Communication Standard (29 CFR 1910.1200). These oils have not been listed in the National Toxicology Program (NTP) Annual Report nor have been classified by the International Agency for Research on Cancer (IARC) as; carcinogenic to humans (Group 1), probably carcinogenic to humans (Group 2), or possibly carcinogenic to humans (Group 2B). These oils have not been classified by the American Conference of Governmental Industrial Hygienists (ACGIH) as: confirmed human carcinogen (A1), suspected human carcinogen (A2), or confirmed animal carcinogen with unknown relevance (A3).

### ECOLOGICAL INFORMATION

#### ECOTOXICITY

This material is not expected to be harmful to aquatic organisms. The ecotoxicity hazard is based on an evaluation of data for the components of a similar material.

#### ENVIRONMENTAL FATE

This material is not expected to be readily biodegradable.

#### DISPOSAL CONSIDERATIONS

Use material for its intended purpose or recycle if possible. Oil collection services are available for used oil recycling or disposal. Place contaminated materials in containers and dispose of in a manner consistent with applicable regulations. Contact your sales representative or local environmental or health authorities for approved disposal or recycling methods.

#### TRANSPORT INFORMATION

The description shown may not apply to all shipping situations. Consult 49CFR, or appropriate Dangerous Goods Regulations, for additional description requirements (e.g., technical name) and mode-specific or quantity-specific shipping requirements.

**DOT Shipping Description:** PETROLEUM LUBRICATING OIL, NOT REGULATED AS A HAZARDOUS MATERIAL FOR TRANSPORTATION UNDER 49 CFR Additional Information: NOT HAZARDOUS BY U.S. DOT. ADR/RID HAZARD CLASS NOT APPLICABLE

**IMO/IMDG Shipping Description:** PETROLEUM LUBRICATING OIL; NOT REGULATED AS DANGEROUS GOODS FOR TRANSPORT UNDER THE IMDG CODE

**ICAO/IATA Shipping Description:** PETROLEUM LUBRICATING OIL; NOT REGULATED AS DANGEROUS GOODS FOR TRANSPORT UNDER ICAO



# Chevron HD 22 - 68 - hydraulic fluid (continued)

## REGULATORY INFORMATION

### EPCRA 311/312 CATEGORIES:

1. Immediate (Acute) Health Effects: NO
2. Delayed (Chronic) Health Effects: NO
3. Fire Hazard: NO
4. Sudden Release of Pressure Hazard: NO
5. Reactivity Hazard: NO

### REGULATORY LISTS SEARCHED:

- |                     |                      |
|---------------------|----------------------|
| 01-1=IARC Group1    | 03=EPCRA 313         |
| 01-2A=IARC Group 2A | 04=CA Proposition 65 |
| 01-2B=IARC Group 2  | 05=MA RTK            |
| 02=NTP Carcinogen   | 06=NJ RTK            |

No components of this material were found on the regulatory lists above.

### CHEMICAL INVENTORIES:

All components comply with the following chemical inventory requirements: AICS (Australia), DSL (Canada), ENCS (Japan), IECSC (China), KECI (Korea), PICCS (Philippines), TSCA (United States)

One or more components is listed on ELINCS (European Union). Secondary notification by the importer may be required.

### NEW JERSEY RTK CLASSIFICATION:

Under the New Jersey Right-to-Know Act L. 1983 Chapter 315 N.J.S.A. 34:5A-1 et. seq., the product is to be identified as follows: PETROLEUM OIL (Hydraulic oil)

### WHMIS CLASSIFICATION:

This product is not considered a controlled product according to the criteria of the Canadian Controlled Products Regulations.

### OTHER INFORMATION

**NFPA RATINGS:** Health: 0 Flammability: 1 Reactivity: 0

**HMIS RATINGS:** Health: 1 Flammability: 1 Reactivity: 0

(0-Least, 1-Slight, 2-Moderate, 3-High, 4-Extreme, PPE:- Personal Protection Equipment Index recommendation,\*-Chronic Effect Indicator). These values are obtained using the guidelines or published evaluations prepared by the National Fire Protection Association (NFPA) or the National Paint and Coating Association (for HMIS ratings).

**LABEL RECOMMENDATION:** Label Category: INDUSTRIAL OIL 1 - IND1

**REVISION STATEMENT:** This revision updates the following sections of this Material Safety Data Sheet:

**Revision Date:** January 15, 2007

### ABBREVIATIONS THAT MAY HAVE BEEN USED IN THIS DOCUMENT:

- |   |  |
|---|--|
| TLV - Threshold Limit Value                                     | TWA - Time weighted Average                        |
| STEL - Short-term Exposure Limit                                | PEL - Permissible Exposure Limit                   |
| CAS - Chemical Abstract Service Number                          | IMDG - International Maritime Dangerous Goods Code |
| API - American Petroleum Institute                              | MSDS - Material Safety Data Sheet                  |
| ACGIH - American Conference of Government Industrial Hygienists | CVX - Chevron                                      |
| NFPA - National Fire Protection Association (USA)               | DOT - Department of Transportation                 |
| NTP - National Toxicology Program(USA)                          | IARC - International Agency for Research on Cancer |
| OSHA - Occupational Safety and Health Administration            |  |

Prepared according to the OSHA Hazard Communication Standard (29 CFR 1910.1200) and the ANSI MSDS Standard (Z400.1) by the Chevron Energy Technology Company, 100 Chevron Way, Richmond, California 94802.

**The above information is based on the data of which we are aware and is believed to be correct as of the date hereof. Since this information may be applied under conditions beyond our control and with which we may be unfamiliar and since data made available subsequent to the date hereof may suggest modifications of the information, we do not assume any responsibility for the results of its use. This information is furnished upon condition that the person receiving it shall make his own determination of the suitability of the material for his particular purpose.**

# Fire Extinguisher - MSDS

---

- [1. PRODUCT AND COMPANY IDENTIFICATION](#)
  - [2. COMPOSITION/INFORMATION ON THE COMPONENTS](#)
  - [3. HAZARD IDENTIFICATION](#)
  - [4. FIRST AID MEASURES](#)
  - [5. FIRE FIGHTING MEASURES](#)
  - [6. ACCIDENTAL RELEASE MEASURES](#)
  - [7. HANDLING AND STORAGE](#)
  - [8. EXPOSURE CONTROLS/PERSONAL PROTECTION](#)
  - [9. PHYSICAL AND CHEMICAL PROPERTIES](#)
  - [10. STABILITY AND REACTIVITY](#)
  - [11. TOXICOLOGICAL INFORMATION](#)
  - [12. ECOLOGICAL INFORMATION](#)
  - [13. DISPOSAL](#)
  - [14. TRANSPORT INFORMATION](#)
  - [15. REGULATORY INFORMATION](#)
  - [16. OTHER INFORMATION](#)
- 

KIDDE  
A UTC FIRE & SECURITY COMPANY

MATERIAL SAFETY DATA SHEET

KIDDE 55 MULTI-PURPOSE DRY CHEMICAL (FIRE EXTINGUISHING AGENT)

## 1. PRODUCT AND COMPANY IDENTIFICATION

PRODUCT NAME:  
KIDDE 55 MULTI - PURPOSE DRY CHEMICAL (FIRE EXTINGUISHING AGENT)

OTHER TRADE NAMES: ABC, AMMONIUM PHOSPHATE, MONOAMMONIUM PHOSPHATE

MANUFACTURER/SUPPLIER:  
KIDDE - RESIDENTIAL AND COMMERCIAL  
A UNITED TECHNOLOGIES COMPANY

ADDRESS:  
1016 CORPORATE PARK DRIVE  
MEBANE, NC 27302  
USA

PHONE NUMBER:  
(919) 304-8200  
(919) 563-5911

CHEMTREC NUMBER (FOR EMERGENCIES ONLY):  
(800) 424-9300  
(703) 527-3887 (INTERNATIONAL)

REVISION DATE: AUGUST 7, 2007

MSDS DATE: JANUARY 15, 2007

THIS MSDS HAS BEEN COMPILED IN ACCORDANCE WITH - EC DIRECTIVE  
91/155/EC - OSHA'S HAZCOM STANDARD (29 CFR 1910.1200)

# Fire Extinguisher - MSDS (Continued)

## 2. COMPOSITION/INFORMATION ON THE COMPONENTS

COMPONENT NAME	CAS#/CODES	CONCENTRATION	R PHRASES	EU CLASSIFICATION
MONOAMMONIUM PHOSPHATE	7722-76-1 EC#2317645	55 - 65%	NONE	NONE
AMMONIUM SULFATE	7783-20-2 EC#2319841	30 - 40%	NONE	NONE
MICA	12001-26-2	1 - 4%	NONE	NONE
CLAY	8031-18-3	<2%	NONE	NONE
AMORPHOUS SILICA	7631-86-9 EC#2315454	<2%	NONE	NONE
DYE	NA	<0.1%	NONE	NONE

## 3. HAZARD IDENTIFICATION

EU MAIN HAZARDS: NON HAZARDOUS POWDER

ROUTES OF ENTRY:

EYE CONTACT

INHALATION

SKIN CONTACT

CARCINOGENIC STATUS: SEE SECTION 11 - TOXICITY

TARGET ORGANS:

RESPIRATORY SYSTEM

SKIN

EYE

HEALTH EFFECTS - EYES:

CONTACT FOR SHORT PERIODS OF TIME MAY CAUSE IRRITATION.

HEALTH EFFECTS - SKIN: CONTACT MAY CAUSE MILD IRRITATION.

HEALTH EFFECTS - INGESTION: INGESTION IS NOT AN EXPECTED ROUTE OF EXPOSURE.

HEALTH EFFECTS - INHALATION:

MAY IRRITATE THE RESPIRATORY TRACT. MAY CAUSE TRANSIENT COUGH AND SHORTNESS OF BREATH.

## 4. FIRST AID MEASURES

EYES:

IMMEDIATELY FLOOD THE EYE WITH PLENTY OF WATER OF WARM WATER FOR AT LEAST 15 MINUTES, HOLDING THE EYE OPEN. OBTAIN MEDICAL ATTENTION IF SORENESS OR REDNESS PERSISTS.

SKIN:

WASH AFFECTED AREA WITH SOAP AND WATER. OBTAIN MEDICAL ATTENTION IF IRRITATION PERSISTS.

INGESTION:

DILUTE BY DRINKING LARGE QUANTITIES OF WATER AND OBTAIN MEDICAL ATTENTION.

INHALATION:

MOVE VICTIM TO FRESH AIR. OBTAIN MEDICAL ATTENTION IMMEDIATELY FOR ANY BREATHING DIFFICULTY.

ADVICE TO PHYSICIANS: TREAT SYMPTOMATICALLY.

# Fire Extinguisher - MSDS (Continued)

---

## 5. FIRE FIGHTING MEASURES

### EXTINGUISHING MEDIA:

THIS PREPARATION IS USED AS AN EXTINGUISHING AGENT AND THEREFORE IS NOT A PROBLEM WHEN TRYING TO CONTROL A BLAZE. USE EXTINGUISHING AGENT APPROPRIATE TO OTHER MATERIALS INVOLVED. KEEP PRESSURIZED EXTINGUISHERS AND SURROUNDINGS COOL WITH WATER SPRAY AS THEY MAY RUPTURE OR BURST IN THE HEAT OF A FIRE.

### UNUSUAL FIRE AND EXPLOSION HAZARDS:

PRESSURIZED CONTAINERS MAY EXPLODE IN HEAT OF FIRE.

### PROTECTIVE EQUIPMENT FOR FIRE-FIGHTING:

WEAR FULL PROTECTIVE CLOTHING AND SELF-CONTAINED BREATHING APPARATUS AS APPROPRIATE FOR SPECIFIC FIRE CONDITIONS.

## 6. ACCIDENTAL RELEASE MEASURES

SWEEP UP OR VACUUM. PREVENT SKIN AND EYE CONTACT. WEAR APPROPRIATE PROTECTIVE EQUIPMENT.

## 7. HANDLING AND STORAGE

PRESSURIZED EXTINGUISHERS SHOULD BE PROPERLY STORED AND SECURED TO PREVENT FALLING OR BEING KNOCKED OVER. DO NOT DRAG, SLIDE OR ROLL EXTINGUISHERS. DO NOT DROP EXTINGUISHERS OR PERMIT THEM TO STRIKE AGAINST EACH OTHER. NEVER APPLY FLAME OR LOCALIZED HEAT DIRECTLY TO ANY PART OF THE EXTINGUISHER OR PLASTIC CONTAINER. STORE PRESSURIZED EXTINGUISHERS AND PLASTIC CONTAINERS AWAY FROM HIGH HEAT SOURCES.

### STORAGE AREA SHOULD BE:

COOL  
DRY  
WELL VENTILATED  
UNDER COVER  
OUT OF DIRECT SUNLIGHT

## 8. EXPOSURE CONTROLS/PERSONAL PROTECTION

### OCCUPATIONAL EXPOSURE STANDARDS:

OCCUPATIONAL EXPOSURE LIMITS ARE LISTED BELOW, IF THEY EXIST.

### MICA:

ACGIH TLV: 3 MG/M3 TWA, MEASURED AS RESPIRABLE FRACTION OF THE AEROSOL.

OSHA PEL: 20 MPPCF, <1% CRYSTALLINE SILICA

### NUISANCE DUST LIMIT:

#### OSHA PEL:

50 MPPCF OR 15 MG/M3 TWA, TOTAL DUST

15 MPPCF OR 5 MG/M3 TWA, RESPIRABLE FRACTION

### ENGINEERING CONTROL MEASURES:

USE WITH ADEQUATE VENTILATION. THERE SHOULD BE LOCAL PROCEDURES FOR THE SELECTION, TRAINING, INSPECTION AND MAINTENANCE OF THIS EQUIPMENT. WHEN USED IN LARGE VOLUMES, USE LOCAL EXHAUST VENTILATION.

# Fire Extinguisher - MSDS (Continued)

## 8. EXPOSURE CONTROLS/PERSONAL PROTECTION

### RESPIRATORY PROTECTION:

NOT NORMALLY REQUIRED. USE DUST MASK WHERE DUSTINESS IS PREVALENT, OR TLV IS EXCEEDED.

### HAND PROTECTION:

NOT NORMALLY NEEDED WHEN USED AS A PORTABLE FIRE EXTINGUISHER. USE GLOVES IF IRRITATION OCCURS.

EYE PROTECTION: CHEMICAL GOGGLES OR SAFETY GLASSES WITH SIDE SHIELDS.

BODY PROTECTION: NORMAL WORK WEAR.

## 9. PHYSICAL AND CHEMICAL PROPERTIES

PHYSICAL STATE: POWDER

COLOR: PALE YELLOW

ODOR: ODORLESS

SPECIFIC GRAVITY: NOT AVAILABLE

BOILING RANGE/POINT (DEG. C/F): NOT APPLICABLE

FLASH POINT (PMCC) (DEG. C/F): NOT FLAMMABLE

SOLUBILITY IN WATER: NOT APPLICABLE

VAPOR DENSITY (AIR = 1): HEAVIER THAN AIR.

VAPOR PRESSURE: NOT APPLICABLE

EVAPORATION RATE: NOT APPLICABLE

## 10. STABILITY AND REACTIVITY

STABILITY: STABLE UNDER NORMAL CONDITIONS.

### CONDITIONS TO AVOID:

HEAT

HIGH TEMPERATURES

EXPOSURE TO DIRECT SUNLIGHT

### MATERIALS TO AVOID:

STRONG OXIDIZING AGENTS

STRONG ACIDS

SODIUM HYPOCHLORITE

HAZARDOUS POLYMERIZATION: WILL NOT OCCUR.

### HAZARDOUS DECOMPOSITION PRODUCTS:

OXIDES OF CARBON

AMMONIA

OXIDES OF PHOSPHORUS

NITROGEN OXIDES

# Fire Extinguisher - MSDS (Continued)

---

## 11. TOXICOLOGICAL INFORMATION

ACUTE TOXICITY: LOW ORDER OF ACUTE TOXICITY.

CHRONIC TOXICITY/CARCINOGENICITY:

THIS PRODUCT IS NOT EXPECTED TO CAUSE LONG TERM ADVERSE HEALTH EFFECTS.

MICA AND CLAY MAY CONTAIN SMALL QUANTITIES OF QUARTZ (CRYSTALLINE SILICA) AS AN IMPURITY. PROLONGED EXPOSURE TO RESPIRABLE CRYSTALLINE SILICA DUST AT CONCENTRATIONS EXCEEDING THE OCCUPATIONAL EXPOSURE LIMITS MAY INCREASE THE RISK OF DEVELOPING A DISABLING LUNG DISEASE KNOWN AS SILICOSIS. IARC FOUND LIMITED EVIDENCE FOR PULMONARY CARCINOGENICITY OF CRYSTALLINE SILICA IN HUMANS.

GENOTOXICITY: THIS PRODUCT IS NOT EXPECTED TO CAUSE ANY MUTAGENIC EFFECTS.

REPRODUCTIVE/DEVELOPMENTAL TOXICITY:

THIS PRODUCT IS NOT EXPECTED TO CAUSE ADVERSE REPRODUCTIVE EFFECTS.

## 12. ECOLOGICAL INFORMATION

MOBILITY: NO RELEVANT STUDIES IDENTIFIED.

PERSISTENCE/DEGRADABILITY: NO RELEVANT STUDIES IDENTIFIED.

BIO-ACCUMULATION: NO RELEVANT STUDIES IDENTIFIED.

ECOTOXICITY: NO RELEVANT STUDIES IDENTIFIED.

## 13. DISPOSAL

DISPOSE OF CONTAINER IN ACCORDANCE WITH ALL APPLICABLE LOCAL AND NATIONAL REGULATIONS. DO NOT CUT, PUNCTURE OR WELD ON OR NEAR TO THE CONTAINER. NO HARM TO THE ENVIRONMENT IS EXPECTED FROM THIS PREPARATION.

## 14. TRANSPORT INFORMATION

DOT CFR 172.101 DATA: NOT REGULATED

UN PROPER SHIPPING NAME: NOT REGULATED

UN CLASS: NONE

UN NUMBER: NONE

UN PACKAGING GROUP: NONE

## 15. REGULATORY INFORMATION

EU LABEL INFORMATION:

CLASSIFICATION AND LABELLING HAVE BEEN PERFORMED ACCORDING TO EU DIRECTIVES 67/548/EEC AND 99/45/EC INCLUDING AMENDMENTS.

EU HAZARD SYMBOL AND INDICATION OF DANGER.:

THIS PREPARATION IS NOT CLASSIFIED AS DANGEROUS.

R PHRASES: NONE

S PHRASES: NONE.

# Fire Extinguisher - MSDS (Continued)

## 15. REGULATORY INFORMATION

US REGULATIONS (FEDERAL, STATE) AND INTERNATIONAL CHEMICAL REGISTRATION LAWS:

### TSCA LISTING:

THIS PRODUCT CONTAINS INGREDIENTS THAT ARE LISTED ON OR EXEMPT FROM LISTING ON THE EPA TOXIC SUBSTANCE CONTROL ACT CHEMICAL SUBSTANCE INVENTORY.

### EINECS LISTING:

ALL INGREDIENTS IN THIS PRODUCT HAVE NOT BEEN VERIFIED FOR LISTING ON THE EUROPEAN INVENTORY OF EXISTING COMMERCIAL CHEMICAL SUBSTANCES (EINECS) OR THE EUROPEAN LIST OF NEW CHEMICAL SUBSTANCES (ELINCS).

### DSL/NDSL (CANADIAN) LISTING:

ALL INGREDIENTS IN THIS PRODUCT ARE LISTED ON THE DOMESTIC SUBSTANCE LIST (DSL) OR THE NON-DOMESTIC SUBSTANCE LIST (NDSL) OR ARE EXEMPT FROM LISTING.

### WHMIS CLASSIFICATION:

D2B

THIS PRODUCT WAS CLASSIFIED IN ACCORDANCE WITH THE HAZARD CRITERIA OF THE CANADIAN CONTROLLED PRODUCTS REGULATIONS AND THE MSDS CONTAINS ALL THE INFORMATION REQUIRED BY THESE REGULATIONS.

### MA RIGHT TO KNOW LAW:

ALL COMPONENTS HAVE BEEN CHECKED FOR INCLUSION ON THE MASSACHUSETTS SUBSTANCE LIST (MSL). THOSE COMPONENTS PRESENT AT OR ABOVE THE DE MINIMIS CONCENTRATION INCLUDE:

MICA	(12001-26-2)	1 - 4%
AMORPHOUS SILICA	(7631-86-9)	<2%
AMMONIUM SULFATE	(7783-20-2)	30 - 40%

### PA RIGHT TO KNOW LAW:

THIS PRODUCT CONTAINS THE FOLLOWING CHEMICALS FOUND ON THE PENNSYLVANIA HAZARDOUS SUBSTANCE LIST:

MICA	(12001-26-2)	1 - 4%
AMORPHOUS SILICA	(7631-86-9)	<2%
AMMONIUM SULFATE	(7783-20-2)	30 - 40%

### NJ RIGHT TO KNOW LAW:

THIS PRODUCT CONTAINS THE FOLLOWING CHEMICALS FOUND ON THE NJ RIGHT TO KNOW HAZARDOUS SUBSTANCE LIST:

MICA	(12001-26-2)	1 - 4%
AMORPHOUS SILICA	(7631-86-9)	<2%

### CALIFORNIA PROPOSITION 65:

THIS PRODUCT DOES NOT CONTAIN MATERIALS WHICH THE STATE OF CALIFORNIA HAS FOUND TO CAUSE CANCER, BIRTH DEFECTS OR OTHER REPRODUCTIVE HARM.

### SARA TITLE III SECT. 302 (EHS):

THIS PRODUCT DOES NOT CONTAIN ANY CHEMICALS SUBJECT TO SARA TITLE III SECTION 302.

### SARA TITLE III SECT. 304:

THIS PRODUCT DOES NOT CONTAIN ANY CHEMICALS SUBJECT TO SARA TITLE III SECTION 304.

### SARA TITLE III SECT. 311/312 CATEGORIZATION:

IMMEDIATE (ACUTE) HEALTH HAZARD

### SARA TITLE III SECT. 313:

THIS PRODUCT DOES NOT CONTAIN ANY CHEMICALS THAT ARE LISTED IN SECTION 313 AT OR ABOVE DE MINIMIS CONCENTRATIONS.

# Fire Extinguisher - MSDS (Continued)

---

## 16. OTHER INFORMATION

### NFPA RATINGS:

NFPA CODE FOR HEALTH 1  
NFPA CODE FOR FLAMMABILITY 0  
NFPA CODE FOR REACTIVITY 0  
NFPA CODE FOR SPECIAL HAZARDS NONE

### HMS RATINGS:

HMS CODE FOR HEALTH 1  
HMS CODE FOR FLAMMABILITY 0  
HMS CODE FOR REACTIVITY 0  
HMS CODE FOR PERSONAL PROTECTION SEE SECTION 8

### ABBREVIATIONS:

N/A: DENOTES NO APPLICABLE INFORMATION FOUND OR AVAILABLE  
CAS#: CHEMICAL ABSTRACTS SERVICE NUMBER  
ACGIH: AMERICAN CONFERENCE OF GOVERNMENTAL INDUSTRIAL HYGIENISTS  
OSHA: OCCUPATIONAL SAFETY AND HEALTH ADMINISTRATION  
TLV: THRESHOLD LIMIT VALUE  
PEL: PERMISSIBLE EXPOSURE LIMIT  
STEL: SHORT TERM EXPOSURE LIMIT  
NTP: NATIONAL TOXICOLOGY PROGRAM  
IARC: INTERNATIONAL AGENCY FOR RESEARCH ON CANCER  
R: RISK  
S: SAFETY

PREPARED BY: ENVIRONET LLC.

THE INFORMATION CONTAINED HEREIN IS BASED ON DATA BELIEVED TO BE ACCURATE. HOWEVER, NO REPRESENTATION, WARRANTY, OR GUARANTEE IS MADE TO ITS ACCURACY, RELIABILITY OR COMPLETENESS. IT IS THE USER'S RESPONSIBILITY TO SATISFY HIMSELF AS TO THE SUITABILITY AND COMPLETENESS OF SUCH INFORMATION FOR ITS OWN PARTICULAR USE. BADGER FIRE PROTECTION ASSUMES NO RESPONSIBILITY FOR PERSONAL INJURY OR PROPERTY DAMAGE RESULTING FROM USE, HANDLING OR FROM CONTACT WITH THIS PRODUCT.



# Battery Material Safety Data

## MATERIAL SAFETY DATA SHEET

Product Identity: Valve Regulated Lead Acid Battery

### 1. HAZARDOUS COMPONENTS

Components	% Weight	TLV	LD50 Oral	LC50 Inhalation	LC50 Contact
Lead (Pb,PbO□PbSO <sub>4</sub> )	about 70%	N/A	(500)mg/kg	N/A	N/A
Sulfuric Acid	about 20%	1mg/m <sup>3</sup>	(2.140)mg/kg	N/A	N/A
Fiber Glass Separat	about 2%	N/A	N/A	N/A	N/A
ABS (Case & Cover	about 8%	N/A	N/A	N/A	N/A

### 2. PHYSICAL DATA

Components	Density	Melting Point	Solubility (H <sub>2</sub> O)	Odor	Appearance
Lead	11.34	327.4°C (Boiling)	None	None	Siler-Grey Metal
Lead Sulfate	6.2	1070°C (Boiling)	40mg/l (15°C)	None	White Powder
Lead Dioxide	9.4	290°C (Boiling)	None	None	Brown Powder
Sulfuric Acid	about 1.3	about 114°C (Boiling)	100%	Acidic	Clear Colorless Liquid
Fiber Glass Separat	N/A	N/A	Slight	Toxic	White Fibrous Glass
ABS (Case & Cover	N/A	N/A	None	None	Solid

### 3. FLAMMABILITY DATA

Components	Flash Point	Explosive Limits	Comments
Lead	None	None	
Sulfuric Acid	None	None	
Hydrogen	-	4%-74.2%	Sealed batteries can emit hydrogen only if overcharged (float voltage>2.3vpc 25°C)
Fiber Glass Separator	N/A	N/A	Toxic vapor may be released. In case of fire; wear self-contained breathing apparatus
ABS	None	N/A	Temperature over 200°C may release gases

### 4. FIRST AID: Sulfuric Acid Precautions

<b>Inhalation</b>	Move to ventilated area. Obtain medical attention
<b>Eyes</b>	Wash the eyes with copious quantities of running water for 15 minutes. Obtain medical attention
<b>Skin</b>	Flush area with large amounts of running water. Remove contaminated clothing and obtain medical attention
<b>Ingestion</b>	Wash out mouth with running water. Do not induce vomiting. Call Physician.

MSDS, January 2008

# Battery Material Safety Data

## 5. REACTIVITY DATA

<b>Component</b>	<i>Sulfuric Acid</i>
<b>Stability</b>	Stable at all temperatures
<b>Polymerization</b>	Will not polymerize
<b>Incompatibility</b>	Reactive metals, strong bases, most organic compounds
<b>Decomposition products</b>	Sulfuric dioxide, trioxide, hydrogen sulfide, hydrogen
<b>Conditions to avoid</b>	Keep away from flames during and immediately after charging. Combustion or overcharging may create or liberate toxic and hazardous gases and liquid including hydrogen, sulfuric acid mist, sulfur dioxide, sulfur trioxide and sulfuric acid Avoid mixing acid with other chemicals

## 6. SPILL OR LEAK PROCEDURES

<b>Step to take in case of leak or spill</b>	Wear protective clothing, Ventilate enclosed areas. Dike to contain contaminated material and liquids. Limit site access to emergency responses. Neutralize with sodium bicarbonate, soda ash, lime, and other neutralizing agents.
<b>Waste disposal method</b>	Return whole scrap batteries to distributor, manufacturer or lead smelter for recycling. For neutralized spills, place residue into containers with absorbent material, sand or earth for disposal. Contact local and/or state environmental officials for proper disposal requirements.

## 7. PROTECTION

Exposure site	Protection	Comments
Skin	Rubber Gloves, Apron	Protective equipment must be worn if the battery is cracked or damaged. A respirator should be worn during certain operations if the TLV is exceeded.
Respiratory	Respirator	
Eyes	Safety Goggles, Face shield	

## 8. ELECTRICAL SAFETY

Due to battery's low internal resistance and high power density, high level of short circuit current could be developed across the battery terminals. Do not rest tools or cables on the battery. Use the insulated tools only. Follow all installation instructions and diagram when installing or maintaining battery systems.
--

## 9. HEALTH HAZARD DATA

<b>Lead</b>	The toxic effects of lead are accumulated and slow to appear. It affects the kidneys, reproductive and central nerves system. The Symptoms of Lead overexposure are vomiting, headaches, stomach pain, Exposure to lead from a battery most often occurs during lead reclaim operations through the breathing or ingestion of lead dust or fumes. <b>THIS DATA MUST BE PASSED TO ANY SCRAP DEALER OR SMELTER WHEN A BATTERY IS RESOLD.</b>
<b>Sulfuric Acid</b>	Sulfuric Acid is a strong corrosive; contact with acid can cause severe burns on the skin and eyes. Acid can be released if the battery case is damaged.

# Guarantee

---

National Flooring Equipment, Inc. (National) warrants to the first consumer/purchaser that this National brand product (**2900 High Speed Ride-on**) when shipped in its original container, will be free from defective workmanship and materials and agrees that it will, at its option, either repair the defect or replace the defective product or part thereof at no charge to the purchaser for parts or labor for the period(s) set forth below.

This warranty does not apply to any appearance items of the product, to the additional excluded items set forth below, or to any product, the exterior of which has been damaged or defaced, which has been subjected to misuse, abnormal service or handling, or which has been altered or modified in design or construction.

In order to enforce the rights under this limited warranty, the purchaser should follow the steps set forth below and provide proof of purchase to National.

The limited warranty described herein is in addition to whatever implied warranties may be granted to purchasers by law. All implied warranties including the warranties of merchantability and fitness for use are limited to the periods from the date of purchase as set forth below. Some states do not allow time limitations on an implied warranty, so the above limitation may not apply to you.

Neither the sales person of the seller, nor any other person, is authorized to make any other warranties other than those described herein, or to extend the duration of any warranties beyond the time period described herein on behalf of National.

The warranties described herein shall be the sole and exclusive warranties granted by National and shall be the sole and exclusive remedy available to the purchaser. Correction of defects in the manner and for the period of time described herein, shall constitute complete fulfillment of all liabilities and responsibilities of National to the purchaser with respect to the product and shall constitute full satisfaction of all claims, whether based on contract, negligence, strict liability or otherwise. In no event shall National be liable, or in any way responsible for any damage or defects in the product which were caused by repairs or attempted repairs performed by anyone other than National. Nor shall National be liable, or in any way responsible, for any incidental or consequential, economics or property damage. Some states do not allow the exclusion of incidental or consequential damages, so the above exclusion may not apply to you.

This warranty gives you specific legal rights. You may also have other rights which vary from state to state.

## WARRANTY PERIOD

The **2900 High Speed Ride-On Self** is guaranteed to be free of manufacturer defective workmanship and in quality of materials for a period of one year.

Items excluded from warranty coverage, unless found and reported defective immediately upon removal from the original shipping container and before being used by the original purchaser.

A freight damage claim must be filed with the carrier by the purchaser, the shipper cannot file the freight claim.

**TO OBTAIN SERVICE CONTACT NATIONAL FLOORING EQUIPMENT, INC. TOLL FREE AT 800-245-0267 FOR A REPAIR AUTHORIZATION NUMBER. COD FREIGHT RETURNS WILL NOT BE ACCEPTED. FREIGHT COLLECT SHIPMENTS WILL NOT BE ACCEPTED. WARRANTY REPAIRS MUST BE ACCOMPANIED BY DATE OF PURCHASE RECEIPT AND A RETURN/REPAIR AUTHORIZATION NUMBER.**

**RETURN/REPAIR AUTHORIZATION NUMBER:** \_\_\_\_\_

**MACHINE SERIAL NUMBER:** \_\_\_\_\_



Made in America Since 1968

9250 Xylon Avenue N • Minneapolis, MN 55445 • U.S.A.  
Toll-free 800-245-0267 • Phone 763-315-5300 • Fax 800-648-7124 • Fax 763-535-8255  
Web Site: [www.nationalequipment.com](http://www.nationalequipment.com) • E-Mail: [info@nationalequipment.com](mailto:info@nationalequipment.com)