

BLASTRAC[®] BS 110 HYDRAULIC SELF-PROPELLED STRIPPER

INSTRUCTION MANUAL



Read Manual Before Operating Machine



 **BLASTRAC**

13201 Santa Fe • Oklahoma City, OK 731141 • U.S.A.
Phone: 800-256-3440

BS110 TABLE OF CONTENTS

■ Table of Contents	2-3
■ Hydraulic	4-5
A. Maintaining A Safe Work Environment	4
B. Pressure.....	4-5
C. Flammability	5
D. Hydraulic Fluid.....	5
■ Rules for Safe Operation.....	6-9
A. Grounding	8
B. Extension Cords	9
■ Transportation	10-11
A. Transport Wheels	10
B. Wheels Engaged/Disengaged	10.1
C. Loading	11
D. Unloading	11.1
■ General Operation.....	12-13
A. Specifications	12
B. Machine Start-up Procedure	12
C. Maintenance	13
D. Inspection Procedure Hydraulic Preventive Maintenance Checklist	13
■ Blades	14-19
A. Blade Setting	14-15
B. Blade Changing.....	15
C. Blade Sharpening	16
D. Blade Chart	17-17.1
E. Types of Tearouts.....	18-19
■ Procedures	20-23
A. Counterweights	20
B. Wheel Adjustment/Removal	20
C. Hydraulic Fluid Level and Changing	21
D. Tank Removal	21
E. Inspection of Internal Parts	22
F. Speed Control	22
G. Pressure Valve Replacement	22
H. Forward and Reverse Switch Replacement.....	22-23
I. Cartridge Replacement	23
J. On/Off Switch Wire Diagram	23
■ Troubleshooting	24
■ Complete Parts List	25-28.1

BS110 TABLE OF CONTENTS

■ Part Numbers and Diagrams.....	29-36
A. External Parts	29
B. Rearview External Parts	30
C. Base Plate Parts	31
D. Idler Assembly Parts	32
E. Pump Drive Assembly Parts	32
F. Eccentric Assembly Parts	32
G. Bearing Parts	32.1
H. Axle Assembly Parts	33
I. Wheel Cleaner Parts	33
J. Internal Handle Parts.....	34
K. Handle Parts	34
L. Hose Parts.....	34
M. Motor Parts	35
N. Body Parts.....	35
O. Switch Parts	35.1
P. Cutting Head Parts	35.1
Q. Internal Parts Parts	36
■ Labels.....	37-37.1
■ Accessories	38
■ 120 Volt Wiring Diagram.....	39
■ Hydraulic Line Layout Diagram	40
■ Material Safety Data	41-46
■ Guarantee.....	47
■ Return Sheet	48
■ Blade Order Form.....	

BS110 HYDRAULIC SAFE OPERATION

MAINTAINING A SAFE WORK ENVIRONMENT

Establishing a safe working environment in and around your hydraulic equipment is just common sense. The easiest and most effective way to avoid problems is to make sure associates understand their equipment, know how to operate it safely and recognize the danger it represents if handled carelessly. A few things you must be aware of include:

1. **PRESSURE:** Hydraulic fluid under pressure is dangerous and can cause serious injury.
2. **FLAMMABILITY:** When ignited, some hydraulic fluids can explode and/or cause fires.
3. **MECHANICAL:** Hydraulic fluid creates movement, which causes parts of your equipment to move or rotate. Always be aware of what you are doing.
4. **MOISTURE:** Never operate in wet or high moisture conditions without a proper GFI grounded switch. Make sure all electrical fittings, switches, cords plus stain reliefs are in good condition. Always unplug when not in use and when doing any service work.
5. **ELECTRICAL:** Disconnect power before servicing. Unplug cord so it can't be started. Faulty wiring can also be an electrical hazard. A regular preventive maintenance program should always include a wiring check.
6. **TEMPERATURE:** Because this machine operates at a relatively low pressure, overheating is not common. If surface of tank becomes too hot to touch by hand (above 130°), shut off machine and allow to cool off.

PRESSURE

Our system runs at or below 1,200 psi. Never look for a leak when unit is under pressure. Using your hand could cause serious injury. A few common ways to encounter hydraulic fluid under pressure include:

1. **PINHOLE:** Fluid under pressure can cause serious injury. It can be almost invisible escaping from a pinhole, and it can pierce the skin into the body. Do not touch a pressurized hydraulic hose assembly with any part of your body. If fluid punctures the skin, even if no pain is felt, a serious emergency exists. Obtain medical assistance immediately. Failure to do so can result in loss of the injured part or death.
2. **LEAK:** Keep fittings and hoses tight. Only check and service when not under pressure. Leaking hydraulic fluid is not only unsightly, it's hazardous. In addition to making workplace floors slippery and dangerous, leaks also contaminate the environment. Before cleaning an oil spill, always check EPA, state and local regulations.

LEAK AT THREAD END/SEAT

Problem: Coupling leaks at thread or seat. This may be caused by any of the following:

- a. Missing or damaged O-rings.
- b. Damaged threads or seat angle.
- c. Thread alignment.
- d. Incompatible thread ends or seat angles.
- e. Over or undertorquing.

Solution: Remove the connection and inspect.

1. Certain couplings require the use of an O-ring. If it is missing, replace it. If an O-ring is used, check for damage caused by installation or possible material breakdown from heat or fluid incompatibility. Alternative O-ring materials may be required. Replace if necessary.

BS110 HYDRAULIC SAFE OPERATION

PRESSURE (continued)

2. Check the threads and/or seat angle for damage that may have occurred prior to or during installation. Any ding or burr may be a potential leak path. Replace if necessary.
3. If the coupling was misaligned during installation, threads may have been damaged. Replace and carefully install.
4. Overtorquing of a threaded connection can stretch and damage threads and mating seat angles. Overtorquing can also damage the staking area of the nut. Undertorquing does not allow proper sealing.

⚠ CAUTION: Never check for leaks over hose or hydraulic connections. Instead, use a piece of cardboard to locate a pressurized leak. For drips (low pressure leaks), use a rag to clean the area and determine where the leak originates.

⚠ CAUTION: Never touch a pressurized hose assembly. Shut down the hydraulic system before checking hose temperature.

3. **BURST:** Whether due to improper selection or damage, a ruptured hose can cause injury. If it bursts, a worker can be burned, cut, injected or may slip and fall.
4. **COUPLING BLOW-OFF:** If the assembly is not properly made or installed, the coupling could come off and hit or spray a worker, possibly resulting in serious injury. Never operate machine without guards.

FLAMMABILITY

With the exception of those comprised primarily of water, all hydraulic fluid is flammable when exposed to the proper conditions (including many “fire-resistant” hydraulic fluids).

Leaking pressurized hydraulic fluids may develop a mist or fine spray that can flash or explode upon contact with a cause of ignition. These explosions can be very severe and could result in serious injury or death.

Precautions should be taken to eliminate all ignition sources from contact with escaping fluids, sprays or mists resulting from hydraulic failures. Sources of ignition could be electrical discharges (sparks), open flames, extremely high temperatures, sparks caused by metal-to-metal contact, etc.

HYDRAULIC FLUID

Only use Texaco RANDO 46 Hydraulic Oil or Compatible Fluid Light IS032. Non-compatible fluids could cause damage to unit or serious injury.

⚠ WARNING: When using electric tools, always follow basic safety precautions to reduce the risk of electric shock and personal injury.

BS110 RULES FOR SAFE OPERATION



READ AND SAVE ALL INSTRUCTIONS FOR FUTURE USE. Before use, be sure everyone operating this equipment reads and understands this manual as well as any labels packaged with or attached to the machine and components and view the instruction video. Extra copies of the manual and video are available upon request.

- 1. KNOW YOUR EQUIPMENT:** Read this manual and view instruction video carefully to learn equipment applications and limitations as well as potential hazards associated with this type of equipment.
- 2. GROUND YOUR TOOL:** See Grounding.
- 3. AVOID DANGEROUS ENVIRONMENTS:** Do not use in rain, damp or wet locations, or in the presence of explosive atmospheres (gaseous fumes, dust or flammable materials). Remove materials or debris that may be ignited by sparks.
- 4. KEEP WORK AREA CLEAN AND WELL LIT:** Cluttered, dark work areas invite accidents.
- 5. DRESS PROPERLY:** Do not wear loose clothing. These may be caught in moving parts. When working outdoors, wear rubber gloves and insulated non-skid footwear. Keep hands and gloves away from moving parts.
- 6. USE SAFETY EQUIPMENT:** Everyone in the work area should wear safety goggles or glasses complying with current safety standards. Wear hearing protection during extended use and a dust mask for dusty operations. Hard hats, face shields, safety shoes, etc. should be worn when specified or necessary.
- 7. KEEP BYSTANDERS AWAY:** Children and bystanders should be kept at a safe distance from the work area to avoid distracting the operator and contacting the tool or extension cord. Operator should be aware of who is around them and their proximity.
- 8. PROTECT OTHERS IN THE WORK AREA:** Provide barriers or shields as needed to protect others from debris and machine operation.
- 9. USE PROPER ACCESSORIES:** Using accessories that are not recommended may be hazardous. Be sure accessories are properly installed and maintained. Do not delete a guard or other safety device when installing an accessory or attachment.
- 10. CHECK FOR DAMAGED PARTS:** Inspect guards and other parts before use. Check for misalignment, binding of moving parts, improper mounting, broken parts and any other conditions that may affect operation. If abnormal noise or vibration occurs, turn the tool off immediately and have the problem corrected before further use. Do not use damaged equipment. Tag damaged tools "DO NOT USE" until repaired. A guard or other damaged parts should be properly repaired or replaced. For all repairs, insist on only identical Blastrac replacement parts.
- 11. REMOVE ALL ADJUSTING KEYS AND WRENCHES:** Make a habit of checking that the adjusting keys, wrenches, etc. are removed from the tool before turning it on.
- 12. GUARD AGAINST ELECTRIC SHOCK:** Prevent body contact with grounded surfaces such as pipes, radiators, ranges and refrigerators. When scoring or making cuts, always check the work area for hidden wires or pipes. Use a Ground Fault Circuit Interrupter (GFCI) to reduce shock hazards.
- 13. AVOID ACCIDENTAL STARTING:** Be sure equipment is turned off before plugging it in. Do not use if the power switch does not turn the machine on and off.
- 14. DO NOT FORCE EQUIPMENT:** Equipment will perform best at the rate for which it was designed. Excessive force only causes operator fatigue, increased wear and reduced control.

BS110 RULES FOR SAFE OPERATION

15. KEEP HANDS AWAY FROM ALL CUTTING EDGES AND MOVING PARTS.

16. WEAR GLOVES WHEN CHANGING BLADES.

17. DO NOT ABUSE CORD: Never unplug by yanking the cord from the outlet. Pull plug rather than cord to reduce the risk of damage. Keep the cord away from heat, oil, sharp objects, cutting edges and moving parts.

18. DO NOT OVERREACH. MAINTAIN CONTROL: Keep proper footing and balance at all times. Maintain a firm grip.

19. STAY ALERT: Watch what you are doing, and use common sense. Do not use when you are tired, distracted or under the influence of drugs, alcohol or any medication causing decreased control.

20. STARTING MACHINE: On/off switch must be in off position before connecting to power source.

21. UNPLUG EQUIPMENT: When it is not in use, unplug tool before changing blades, accessories or performing recommended maintenance or when not in use.

22. MAINTAIN EQUIPMENT CAREFULLY: Keep handles dry, clean and free from oil and grease. Keep cutting edges sharp and clean. Follow instructions for lubricating and changing accessories. Periodically inspect tool cords and extension cords for damage. Have damaged parts repaired or replaced.

23. STORE IDLE EQUIPMENT: When not in use, store in a dry, secured place. Keep away from children.

24. MAINTAIN LABELS AND NAMEPLATES: These carry important information. If unreadable or missing, contact Blastrac for a free replacement.

⚠ WARNING: Exposure to dust may cause respiratory ailments. Use approved NIOSH or OSHA respirators, safety glasses or face shields, gloves and protective clothing. Provide adequate ventilation to eliminate dust, or to maintain dust level below the Threshold Limit Value for nuisance dust as classified by OSHA.

25. MACHINE IS HEAVY, DO NOT DROP: Counter weights are heavy. Take caution when removing or reassembling. Take caution when moving or transporting.

BS110 RULES FOR SAFE OPERATION

GROUNDING

⚠ WARNING: Improperly connecting the grounding wire can result in the risk of electric shock. Check with a qualified electrician if you are in doubt as to whether the outlet is properly grounded. Do not modify the plug provided with the tool. Never remove the grounding prong from the plug. Do not use the tool if the cord or plug is damaged. If the plug will not fit the outlet, have a proper outlet installed by a qualified electrician.

⚠ WARNING: Electrical cords can be hazardous. Misuse can result in fire or death by electrical shock. Read carefully and follow all directions.

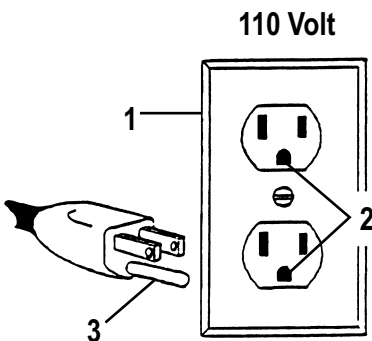

Figure A

1. Cover of grounded outlet box
2. Outlet ground
3. Grounding prong

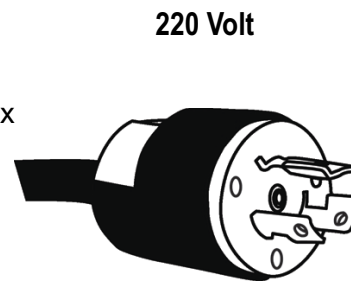

Figure B

GROUNDING TOOLS: TOOLS WITH THREE PRONG PLUGS

Tools marked "Grounding Required" have a three wire cord and three prong grounding plug. The plug must be connected to a properly grounded outlet (Figure A & B). If the tool should electrically malfunction or break down, grounding provides a low resistance path to carry electricity away from the user, reducing the risk of electric shock.

The grounding prong in the plug is connected through the green wire inside the cord to the grounding system in the tool. The green wire in the cord must be the only wire connected to the tool's grounding system and must never be attached to an electrically "live" terminal.

Your tool must be plugged into an appropriate outlet, properly installed and grounded in accordance with all codes and ordinances. The plug and outlet should look like those in Figure A & B.

BS110 RULES FOR SAFE OPERATION

EXTENSION CORDS

⚠ WARNING: Electrical cords can be hazardous. Misuse can result in fire or death by electrical shock. Read carefully and follow all directions.

Grounded tools require a three wire extension cord. Double insulated tools can use either a two or three wire extension cord. As the distance from the supply outlet increases, you must use a heavier gauge extension cord. Using extension cords with inadequately sized wire causes a serious drop in voltage, resulting in loss of power and possible tool damage.

The smaller the gauge number of the wire, the greater the capacity of the cord. For example, a 14 gauge cord can carry a higher current than a 16 gauge cord. When using more than one extension cord to make up the total length, be sure each cord contains at least the minimum wire size required. If you are using one extension cord for more than one tool, add the nameplate amperes and use the sum to determine the required minimum wire size.

GUIDELINES FOR USING EXTENSION CORDS

- If you are using an extension cord outdoors, make sure it is marked with the suffix “W-A” (“W” in Canada) to indicate that it is acceptable for outdoor use.
- Be sure your extension cord is properly wired and in good electrical condition. Always replace a damaged extension cord or have it repaired by a qualified person before using it.
- Protect your extension cords from sharp objects, excessive heat and damp or wet areas.
- Keep away from water. Do not use if wet. 
- Inspect thoroughly before each use. **DO NOT USE IF DAMAGED.**
- Make sure equipment is OFF before connecting cord outlet.
- FULLY INSERT plug into outlet.
- Do not remove, bend or modify any metal prongs or pins of cord.
- Do not use excessive force to make connections.
- Do not connect a three prong plug to a two-hole cord.
- Avoid overheating. Uncoil cord and do not cover it with any material.
- Do not walk on cord.
- Do not drive, drag or place objects over cord.

READ AND SAVE ALL INSTRUCTIONS FOR FUTURE REFERENCE.



BS110 TRANSPORTATION

TRANSPORT WHEEL ASSEMBLY

- Transport wheels help to eliminate damage to flooring and make movement of unit easier.

ATTACHING TRANSPORT WHEELS

- Remove two outside blade cover bolts (See Figure A).

⚠ WARNING: Make sure machine is stable and secure on blocks.

- Tip machine back and block up front of machine so cutting head has enough clearance for front wheel assembly to fit under. See Figure B or, lay unit on side and block up (See Figure C).
- Mount front wheel assembly over blade cover (See Figure A). Replace two outside blade cover bolts.
- Remove blocks.
- DO NOT leave machine in transport mode while in transit in vehicle without machine being secured.

REMOVAL OF TRANSPORT WHEELS

- Reverse procedure from above.

⚠ WARNING: Never have transport wheel assembly mounted onto machine or wheels disengaged when going up or down a loading ramp or incline. (See Page 10.1). Failure to do so could cause machine runaway, damage to machine, damage to property or cause serious injury.

#06-6280-301 Front Transport Wheel



Figure A

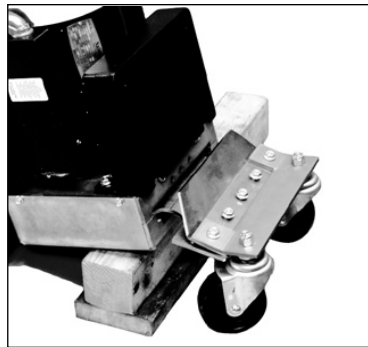

Figure B

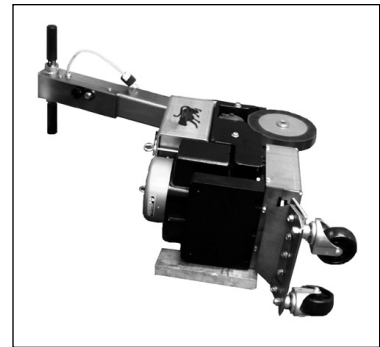

Figure C

BS110 TRANSPORTATION

Wheels engage and disengage for easier maneuverability. Wheels in the “engage mode” are secured with the axle pins (See Figure A). This engages the wheels for the machine to be self-propelled.

When wheels are in the “disengage mode” (See Figure B). Machine can be moved around freely when the machine IS NOT under power.

WHEELS ENGAGING OR DISENGAGING

DISENGAGING WHEELS

⚠ WARNING: Never load or unload machine on a ramp or incline when wheels are in the disengage mode. Failure to do so could cause machine runaway, damage to machine, damage to property or cause serious injury.

Move machine so pin is vertical (See Figure C). Pull up on end of pin to release. Slide pin out. Repeat on second wheel. **Note:** Keeping axle pin facing straight up will make re-engaging easier.

RE-ENGAGING WHEELS

Line up wheel hub hole and axle hole (See Figure D). Insert axle pin and secure pin end. Repeat on second wheel.

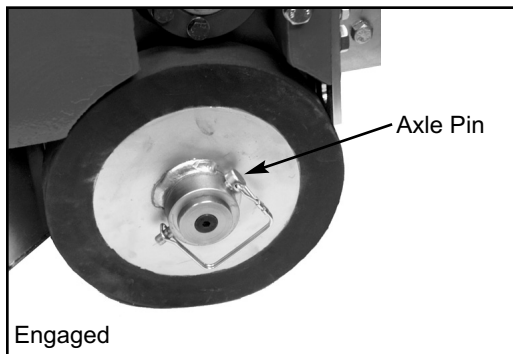

Figure A

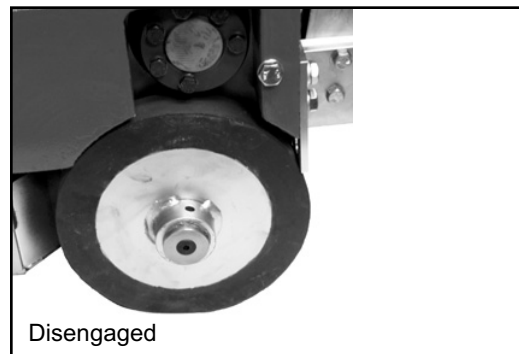

Figure B

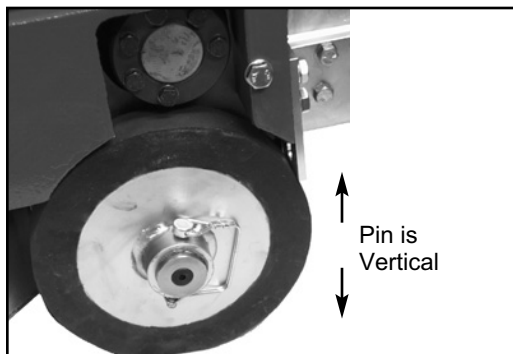

Figure C

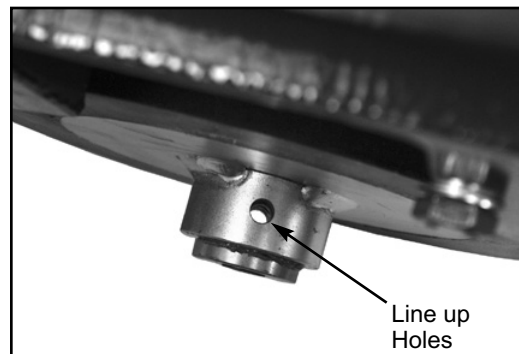

Figure D

⚠ WARNING: Never have transport wheel assembly mounted onto machine when wheels are in the disengage mode.

BS110 TRANSPORTATION

⚠ WARNING: When maneuvering machine on any type of a incline (ramp, hill, etc.), wheel engage pins MUST be in place (in engaged mode) (See Figure B) and counterweights removed.

LOADING

ALWAYS REMOVE ALL COUNTERWEIGHTS AND BLADES BEFORE LOADING OR UNLOADING.

LIFTING BAIL

- Easy loading when not driving or using a ramp.
- Use rope, hook system or chain through eyelets located on top of machine (See Figure A).
- Location on lifting bails centrally locates balance of the machine to safely pick-up machine.
- Raise machine with a fork lift or winch.

⚠ WARNING: Keep hands and feet out from under machine.

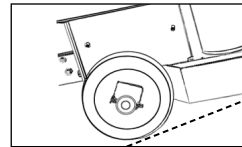

CORRECT

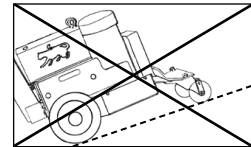

INCORRECT

RAMP

⚠ WARNING: Only load or unload machine on a ramp with wheel pins engaged (engage mode) (See Figure B) and counterweights removed. Failure to do so could cause machine runaway, damage to machine, damage to property or cause serious injury. See Page 10.1 for wheel engage mode.

⚠ WARNING: Make sure ramp is secure before using. Failure to do so could cause ramp to fall away from truck, causing damage to the machine and/or injury to the operator.

- All counterweights, blades and transport wheels must be removed before unloading (or loading).
- Make sure ramp is clean and dry, free of grease or oil.
- Attach ramp securely to back of vehicle, making sure there is good contact (See Figure C).
- Position machine at back of ramp (See Figure A). Engage power switch and drive onto vehicle.



Figure A

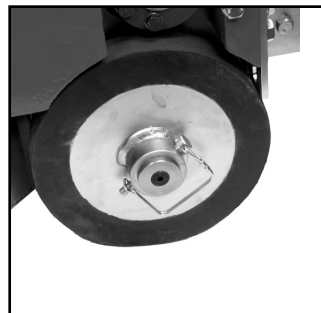

Figure B



Figure C

BS110 TRANSPORTATION

UNLOADING

- Position machine at the back of the truck in line with the ramp (See Figure B).
- Carefully move machine onto ramp leaving cutting head down (in contact with ramp surface).

⚠ WARNING: Ramp must have good contact with the back of the vehicle. Failure to do so could cause ramp to lose contact with back of vehicle resulting in damage to the machine or injury to the operator.

- Even without counterweights machine weighs 250 pounds
- Make sure you have machine under control. Failure to do so could cause machine runaway, damage to machine, damage to property or cause serious injury.
- Slowly back machine down ramp.

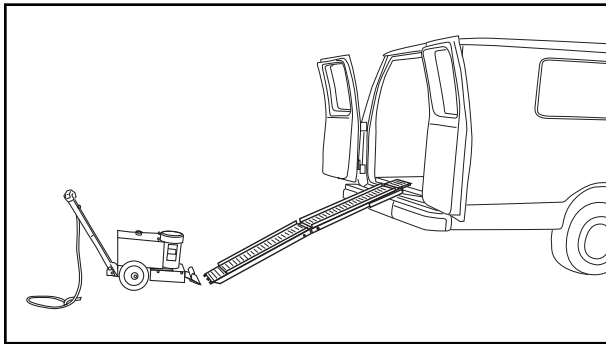

Figure A

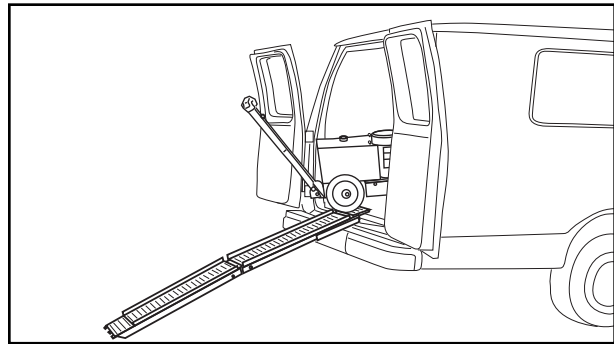
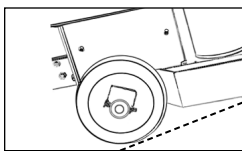
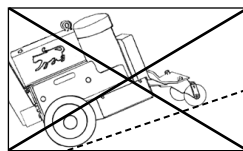

Figure B



CORRECT



INCORRECT

⚠ WARNING: Never load or unload machine on a ramp or incline when wheels are in the disengage mode. Failure to do so could cause machine runaway, damage to machine, damage to property or cause serious injury.

BS110 GENERAL OPERATION

SPECIFICATIONS

SPECIFICATIONS	BS110
Length:	27.5"
Width:	13"
Height:	41"
Weight (machine only):	360 lbs.
Speed:	10 - 45 feet per minute
MOTOR INFORMATION	
RPM:	3450
Volts:	110
HP:	1½
Amps-Full Load:	13
Continuous Duty	

A well-maintained machine is a productive machine. If not properly maintained, it could be unsafe and could break down. A scheduled maintenance program should insure a long system life and a safe work environment.

MACHINE START UP PROCEDURE

TO RUN MACHINE:

1. Machine **MUST** be off before plugging machine into power source.
2. Plug machine into outlet.
3. Turn speed control to slowest position.
4. Turn machine on.
5. Engage forward or reverse switch.
6. Increase speed control to desired speed.

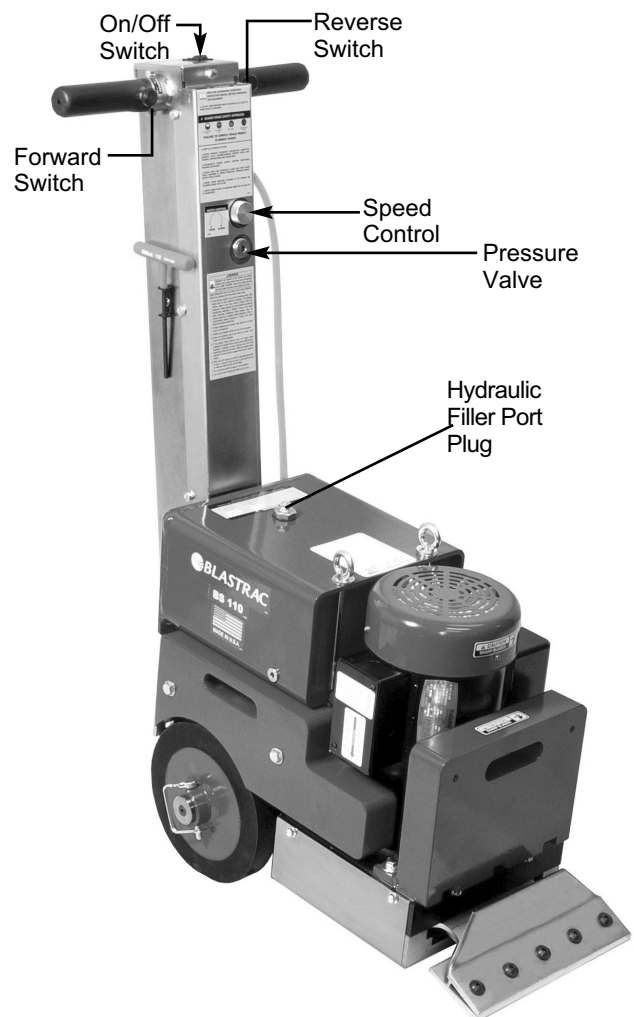

BS110 GENERAL OPERATION

MAINTENANCE

1. Always wear eye protection.
2. Keep flammable and fragile objects away from this tool.
3. Always check nuts and bolts to make sure they are tight.
4. Always use the tool with proper voltage specified in the machine's name plate.
5. Always keep guards in place.
6. Do not operate around water or wet conditions without use of GFI on cord.
7. Use properly grounded cord and receptacle.
8. Unplug from power before servicing.
9. Use 12 gauge or heavier wire cord, not exceeding 50 feet in length.
10. Do not force machine.
11. Do not alter machine.
12. Pressure valve has been factory set and should NOT be tampered with.
13. Hydraulic Fluid: Keep clean and at a proper level. See Page 21.
14. Keep wheels free from debris. See page 20.

INSPECTION PROCEDURE HYDRAULIC PREVENTIVE MAINTENANCE CHECKLIST

By following this preventive maintenance checklist, you can maintain your equipment hose efficiently, safely and with very little effort. Each step is covered in detail in the following section.

⚠ WARNING: Do not lock wheel drive into a permanent on position. If operator would lose control or be disabled, machine continues to operate.

- Always turn off and unplug electrical source before servicing.
- Place equipment and components in a safe or neutral position.
- Remove access panels (if any) and inspect hose and fittings for damage or leaks.
- Repair or replace as needed.
- Inspect all hydraulic components.
- Reinstall the access panels.
- Turn power back on.
- Be aware of your equipment, always look and listen for anything unusual.

BS110 BLADES

BLADE SETTING

- Dull blades greatly reduce cutting ability. Re-sharpen or replace as needed.
- Proper blade size and placement, depending on material and sub-floor type, affects performance.
- The harder a job comes up, for best results, use a smaller blade.
- Start with a narrow blade, then increase blade size to optimize cutting pass. Narrower blades work easier than wider blades and usually clean the floor better. Wider is not always better or faster.
- Normally bevel on blade is up for concrete. Bevel down for wood or soft sub-floors.



BEVEL UP
CONCRETE FLOORS



BEVEL DOWN
WOOD FLOORS

- Wood or wood like floors: pound down or remove any nails or metal obstruction to avoid blade damage.
- Blades can be offset in cutting head for easier access to toe kicks or removal along the wall (See Figure A).
- Sheet vinyl, solid vinyl, rubber tile, urethane or PVC sheet roofing, will need to be scored for best removal results (See Figure B).
- Score flooring to the width of the blade (See Figure C).
- Keep in mind, narrow width blades will make a cleaner floor surface.
- **KEEP BLADES SHARP!**
- Dull blades greatly affect the performance of the machine.

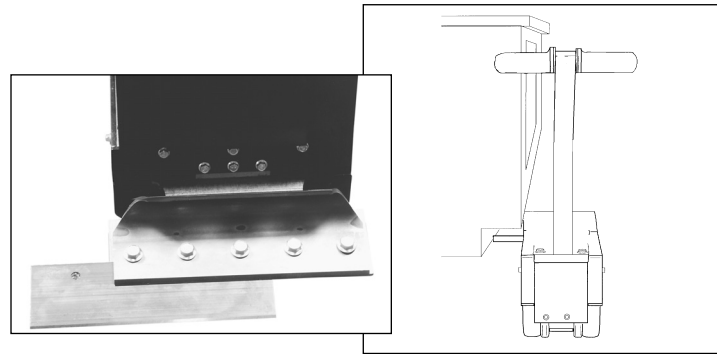

Figure A

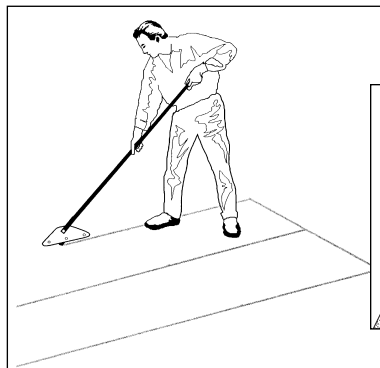

Figure B

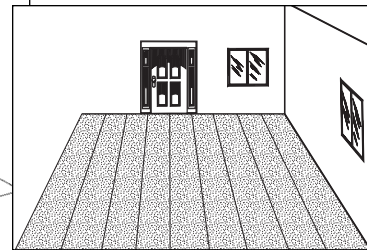

Figure C

BS110 BLADES

BLADE SETTING (continued)

- Self scoring blades are available in a number of sizes. These blades eliminate the need for pre-scoring material. Depending upon the type of material being removed and the sharpness of the blade and scoring wings, the self scoring blades may make it harder to control the machine.
- Keep scoring wings sharp at all times.
- Keep your work area clean and clear of debris.
- After you have removed a portion of material, remove it out of the way. This will give the machine maximum performance and help to keep the work area safe.

BLADE CHANGING

⚠ CAUTION: Blades are sharp.

- Sharp blades are imperative for good performance.
- Always wear gloves when changing blades.
- Use supplied extended wrench or a socket wrench with at least a 3" extension to keep hand safely away from the sharp edge of the blade.
 1. Place a block under the front of the machine as shown in Figure A, using a flat piece of 2 x 4 or something similar.
 2. Loosen five (5) hex head bolts with extended bolt wrench (See Figure B). It is not necessary to remove bolts. Place blade into cutting head, sliding all the way back to the bolts. If the blade is wider than the cutting head, center blade to head. If blade is smaller than the cutting head, first pass blade should be mounted in center of the cutting head. After first pass is made, blade can be offset in head to allow wheels to keep even contact with the floor and allow easy access to the wall.

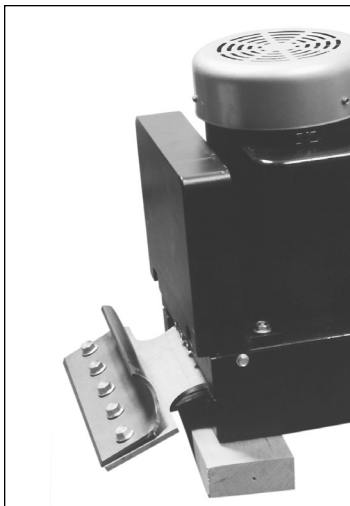

Figure A



Figure B

BS110 BLADES

BLADE SHARPENING

- Always wear gloves and safety glasses.
- Using hand grinder, block up front of machine so blade is off the floor.
- Grind blade using a 4" diameter disk with 120 or finer grit. Be careful not to catch disk on edge or corner of blade. Blade bevel up. See Figure A. Blade bevel down (See Figure B).
- Pass grinder back and forth along blade edge being careful to hold grinder at proper angle of blade. Grind until sharp.
- Using a good quality fine tooth hand file, use same procedure as above (See Figure C).
- Blades are sharp. Use extreme caution.
- Have plenty of sharp blades on each job so on-the-job blade sharpening is eliminated.
- It is best to resharpen dull blades on proper bench or belt grinder in the shop, so the blades are ready for the next job.

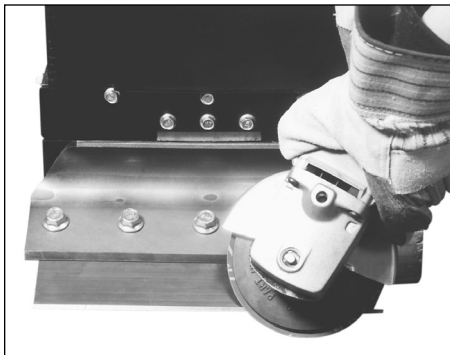

Figure A



Figure B

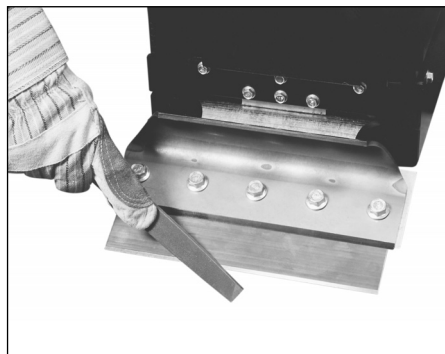
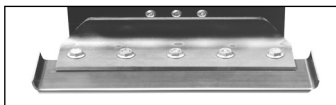
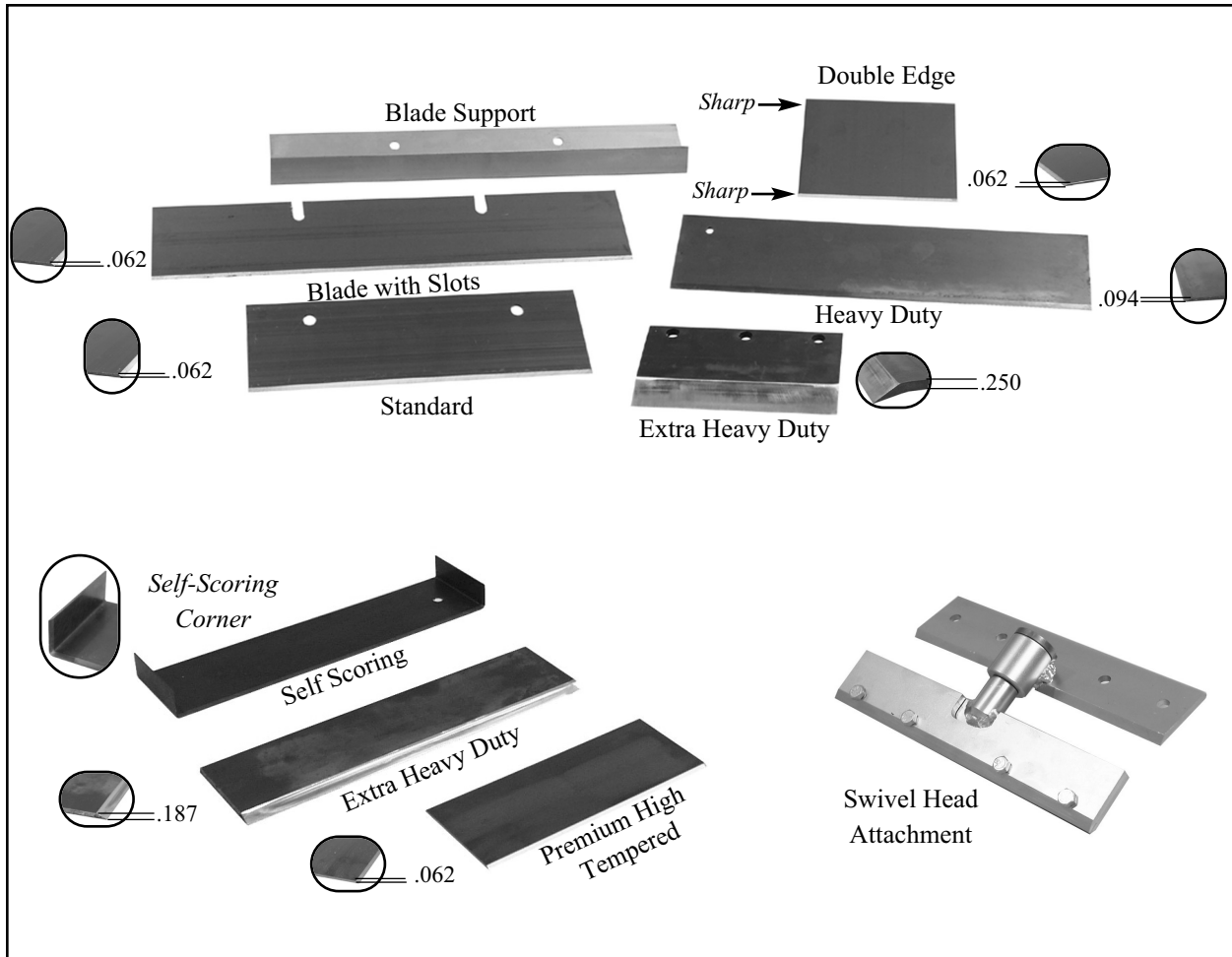

Figure C

BS110 BLADES



SELF SCORING BLADES: Eliminates pre-scoring carpet. See sizes and accessories on Page 17.1.

BS110 BLADES

Part #	Description	Application	Thickness
06-130-S	3" x 10" Blade with slots	Glued down carpet, tile or resilient	.062
06-130-D	#130 Blade with both edges sharpened	Carpet, tile or resilient on wood & concrete floors	.062
06-131-S	3" x 16" Blade with slots	Glued down rubber carpet, floor accumulation	.062
06-135	5" x 16" Blade	Rubber back carpet on wood or concrete floors, excellent for cleanup and longer durability	.062
06-136	5" x 8" Blade	Removal of wood flooring	.062
06-147	4" x 6" Blade	Tile or linoleum on concrete floors	.062
06-147-D	#147 Blade with both edges sharpened	Tile or linoleum on concrete floors	.062
06-148	5" x 6" Blade	Tile or linoleum on wood floors	.062
06-148-D	#148 Blade with both edges sharpened	Tile or linoleum on wood floors	.062
06-363-2	3/4" x 8" Scraper Blade (50/pkg)	Razor sharp, super hard for scraping thin epoxies, thin mil coatings like; urethane paint, poured elastomeric coatings up to 60 mil, hard to remove adhesive and much more	.032
06-368-8	7/8" x 8" Razor/Scraper Blade (50/pkg)		.045
06-368-12	7/8" x 12" Razor/Scraper Blade (50/pkg)		.045
06-368-15	7/8" x 15" Razor/Scraper Blade (50/pkg)		.045
06-6255-BU	4" x 6" Self Scoring Blade - Bevel Up	Works on attached cushion, Unitary or secondary backing, vinyl backing, soft to medium Pvc, linoleum, carpet tiles, soft cork, Enhancer and Uniband hot melts	.062
06-6257-BU	3" x 9" Self Scoring Blade - Bevel Up		.062
06-6258-BU	3" x 12" Self Scoring Blade - Bevel Up		.062
06-6259-BU	3" x 14" Self Scoring Blade - Bevel Up		.062
06-6277-BU	3" x 12" Self Scoring Blade	Same application as the .062 blade. 45° angle, self scoring wings for easy sharpening. The thickness greatly reduces breakage.	.094
06-6278-BU	3" x 14" Self Scoring Blade		.094
06-6270	1-1/2" x 3" Extra Heavy Duty Blade	Ultra tough coatings, ceramic & hardwood	.250
06-6271	3" x 6" Extra Heavy Duty Blade	Ultra tough coatings, ceramic & hardwood	.250
06-6273	3" x 11" Extra Heavy Duty Blade	Ultra tough coatings, ceramic & hardwood	.250
06-6280-500	Holds razor blades up to 1" wide	Unique attachment rotates to use the other sharp edge without having to change blade. Works on thin soft coatings, paint, hard to remove gummy or dry adhesives.	
06-6281	3" x 8" Heavy Duty Blade	A heavy duty blade that still gives a little flex. Made with Nationals proven blade hardening process, these blades will stay sharper longer with better overall performance than any other blade on the market. Works on Vct, Vat, wood, tile, rubber epoxy, thin-set, elastomeric coatings, scraping thin-set, glued ceramic	.094
06-6282	3" x 14" Heavy Duty Blade		.094
06-6284	3" x 12" Heavy Duty Blade		.094
06-6285	3" x 6" Heavy Duty Blade		.094
06-6286	3" x 10" Heavy Duty Blade		.094
06-6290	3" x 6" Extra Heavy Duty Blade	Extremely hard, high abrasion alloy for tough tear-up situations. Vct, Vat, wood, tile, thin ceramic, re-scraping thin-set, all carpets, cork, elastomeric coatings, re-scraping rubber and urethane coatings. Holds the edge extremely well.	.187
06-6291	3" x 8" Extra Heavy Duty Blade		.187
06-6292	3" x 12" Extra Heavy Duty Blade		.187
06-6293	3" x 14" Extra Heavy Duty Blade		.187
06-7050-200	3" x 6" Premium High Tempered Blade	Ultra high quality spring steel is extra hard for long blade life between sharpening. Works on all glue down carpets, Vct, Vat, rubber tile, cork, re-scraping adhesive, elastomeric coatings. Great for floor accumulations	.062
06-7050-201	3" x 8" Premium High Tempered Blade		.062
06-7050-202	3" x 10" Premium High Tempered Blade		.062
06-7050-203	3" x 12" Premium High Tempered Blade		.062
06-7050-204	3" x 14" Premium High Tempered Blade		.062
06-7080	3" x 8" Increased Angle Blade	Mainly used for VCT but can be used on most other applications. Supplies more of an angle when needed. Prevents machine from jumping off material.	.062
06-7081	3" x 10" Increased Angle Blade		.062

BS110 BLADES

⚠ WARNING: Never remove flooring containing asbestos without fully understanding proper state and federal procedures and guidelines.

TYPES OF TEAROUTS

REMOVAL MATERIALS

- **VCT TILE:** Never use a blade wider than the size of the tile being removed (See Figure A). If goods being removed still do not come up clean or machine jumps on top of goods, reduce blade size to a smaller blade until proper blade size is found or use a smaller portion of the blade.
- **PURE VINYL RUBBER TILE:** Goods will need to be scored down to 10 to 12 inches for proper removal (See Figure B). Self scoring blades can be used with some materials. A 10" blade is recommended for this product, but determine what size blade works best.
- **CERAMIC (Glued with Double Duty or Mudsets):** Before removing ceramic tile, tiles will have to be pre-broke with a mallet or large hammer. On small random block styles of tile, pre-breaking may not be necessary. Open an area large enough for machine or blade to fit in, or start from a doorway. Keep work area clean to keep good wheel contact with floor. Use slow speed and small blades. Ripper Teeth may need to be used first.
- **DIRECT GLUED CARPET:** Can be done with either self scoring blades (Figure C) or pre-score carpet to blade width prior to stripping with #584 Scoring Tool. Pre-scored carpet makes machine easier to control and blades stay sharper longer. Blades up to 16" wide can be used. Normally 12" to 14" blades are used on direct glued carpet, secondary backed, unitary, double glued, vinyl foam, urethane foam. Latex foams come up easily with a 16" blade.

1. Remove five (5) hex head bolts.
2. Remove blade holder.
3. Replace with Ripper Teeth plate. Replace and tighten five (5) hex head screws.

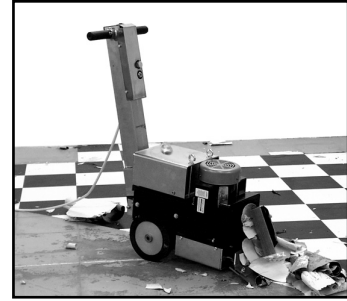

Figure A



Figure B

Bevel Up

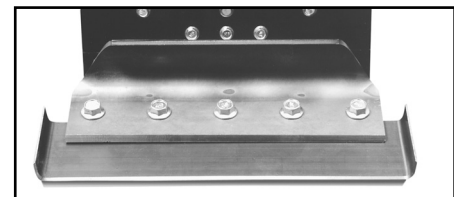

Figure C

BS110 TYPES OF TEAR-OUT

TYPES OF TEAROUTS (continued)

SUBFLOOR SURFACES

- **WOOD:** When working over plywood sub-flooring, try to run machine in the same direction as the grain in the wood. Blade in most cases bevel down. On solid wood floors like plank, run in the same direction as the plank, not cross grain or cross plank. Removing the front counter weight will help on all soft surfaces.
- **CONCRETE:** When working on concrete slab, normal blade position is bevel up for best performance, especially when cleaning adhesive. On occasion, bevel down gives better blade life. Test each job for best performance.
- **GIBCRETE AND SOFT POURED FLOORING:** Usually require blade bevel down to create a better wearing surface, although bevel up may work if front counter weight is removed.



BEVEL DOWN



BEVEL UP

⚠ CAUTION: Beware of expansion joints and floor mounted receptacles or other obstacles in the floor.

EYE PROTECTION SHOULD BE USED AT ALL TIMES.

- **GLUED HARD WOOD FLOORING:** A 10" blade is recommended for regular adhesive, a 6" blade for epoxy. For proper removal of hardwood flooring (plank solid, plank laminated, parkay laminated), flooring must be scored to blade width. This is done by using a circular saw set at a depth of 99% of the thickness of the board, just missing the subfloor surface when on concrete (See Figure A). A chalk line for scoring lines can be used across the floor the width of the blade (See Figure B). A ripping guide attached to the saw can be used to eliminate chalk line marks. Open an area large enough to fit machine or start from a doorway. It is important to keep all debris cleaned up for maximum performance of machine. True Parkay flooring scoring is not necessary. It will come up in small pieces.

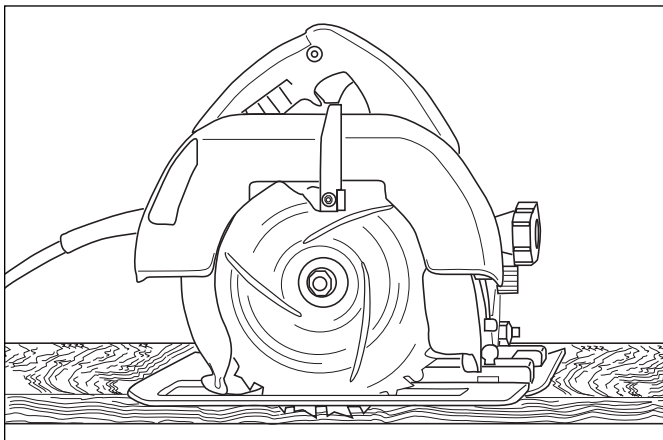

Figure A

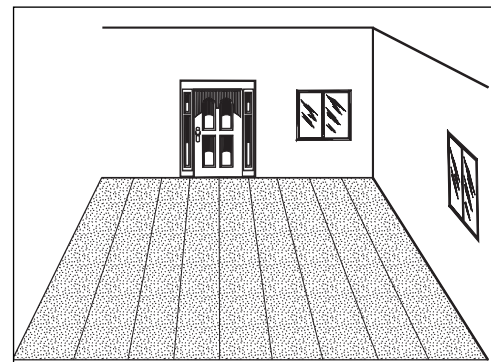

Figure B

BS110 PROCEDURES

COUNTERWEIGHTS

- It is not necessary to have counter weights on to use machine. Use only as needed (See Figure A).
- Use 9/16" blade wrench (supplied). Each counter weight is attached with two 3/8" bolts. Remove bolts and counter weights. Weights are heavy, use caution when removing or mounting.
- Weights – 44 lbs., front weight – 41 lbs., each side weight.
- Machine total weight with counterweights – 378 lbs..
- Machine weight without counterweights – 250 lbs..
- Optional additional front weight, #110-6250 –146A (not shown).

WHEEL CLEANER ADJUSTMENT

- Unplug machine.
- Loosen wheel cleaner with 9/16" wrench (See Figure B).
- Slide cleaner up to face of wheel until it touches but DOES NOT dig into wheel surface.
- Retighten firmly.
- Over tightening wheel cleaner could cause damage to wheel.

CAUTION: Pinch Point.

WHEEL REMOVAL

- Examine back of wheels (with a flashlight is helpful) to see if debris is built up.
- Keep clean from yarn build up.
- Unplug machine.
- Lay machine on its side.
- Use provided 3/16" allen wrench.
- Remove Axle Pin (new style only) (See Figure D).
- Remove wheel securing screw (See Figure C & D).
- Remove wheel securing cap.
- Wheel will slide off. Watch for keyway key. DO NOT LOSE.
- Remove wheel spacer. This should be inspected at regular intervals.

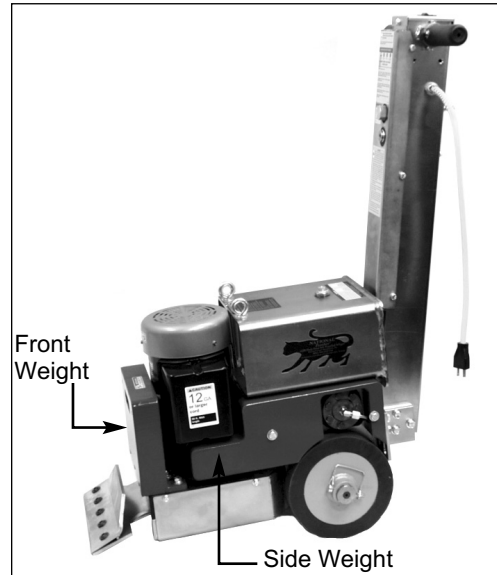

Figure A

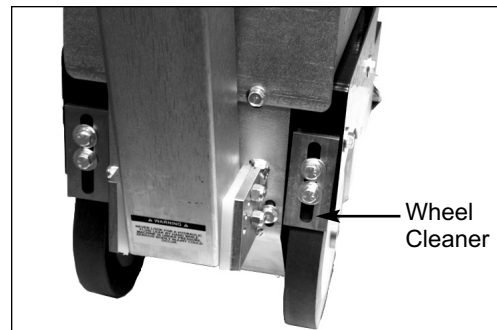
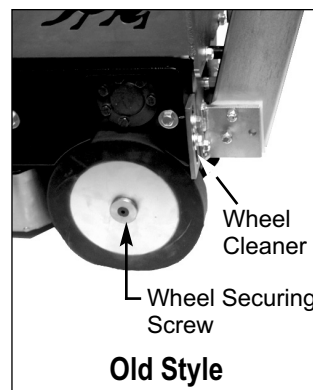
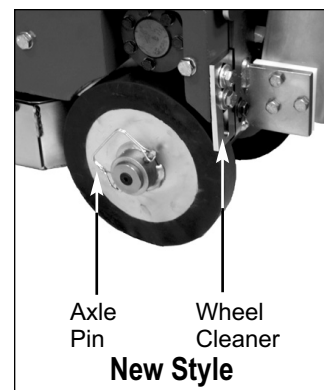

Figure B



Old Style

Figure C



New Style

Figure D

BS110 PROCEDURES

HYDRAULIC FLUID LEVEL

- Machine is run at a low temperature and pressure.
- Check fluid level if there has been a leak, damaged or ruptured hose or a loose fitting.
- Fluid level should be higher than the Return Line. See Figure A. Or from the Filler Port, 1" from the top of the tank (See Figure B).
- Machines have a fluid level sight window. See Figure A. The fluid should be in the middle to the top of the window when the machine is sitting in a normal operating position without a blade. If your machine does not have a sight window, fluid should be 1" from the top of the tank.

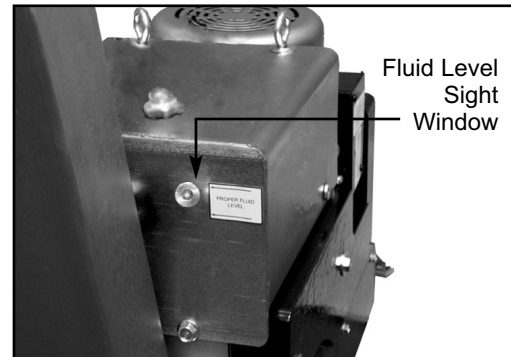

Figure A

ADDING OR CHANGING HYDRAULIC FLUID

- Occasionally blow out the Filler Port Cap filter to remove debris.
- Change or add fluid only when needed.
- To add fluid, unscrew Filler Port Cap from top of machine (See Figure B).
- To change fluid, remove Filler Port Cap. Remove drain plug from side of machine (See Figure C). A container approximately two gallons in size will be needed to drain fluid into (fluid will not be removed from hoses).
- Machine has a straining system, but add fluid through a filter or funnel with a screen to keep fluid clean.
- Use Texaco RANDO 46 Hydraulic Oil Light, stock #110-6280-1 or comparable.

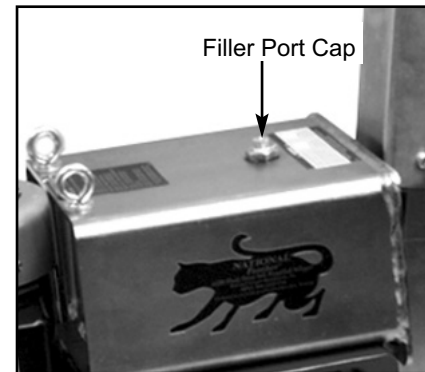

Figure B

TANK REMOVAL

Removing the tank will be necessary to repair the pump or to replace or service internal hoses.

- Drain tank by removing top Filler Port Cap and Drain Plug on side of machine (See Figure C). A container approximately two gallons in size will be needed to drain fluid into.
- Replace Drain Plug and Filler Port Cap.
- Remove two lifting bail eyebolts and the two bolts from the back of the tank.
- Disconnect return line on back of tank, carefully lift tank 3" to 4" and disconnect suction line. Tank can now be removed.

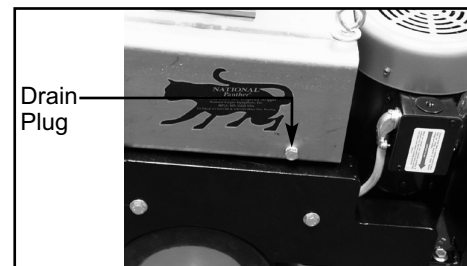

Figure C

BS110 PROCEDURES

INSPECTION OF INTERNAL PARTS

Visual inspection of internal parts can be done without draining tank.

- Remove two lifting bail eyebolts and the two bolts from the back of the tank.
- Carefully lift tank 3" to 4".
- Using a flashlight, inspect drive chain, hoses, front seal on motor, and suction and pressure line on pump.
- If service is necessary, follow procedure for tank removal.

SPEED CONTROL

- Speed control knob can be adjusted while machine is running.
- Turning speed control knob counter clockwise will make machine run faster (See Figure C).
- Turning speed control knob clockwise will make machine run slower (See Figure C).

SPEED CONTROL REPLACEMENT

- Use a 3/32" allen wrench to remove plastic knob.
- Use a 1" deep socket to remove and replace speed control valve.
- Re-install plastic knob.

PRESSURE VALVE REPLACEMENT

This has been factory set and should not be tampered with.

- Use a 1" deep socket to remove old unit and install new.

FORWARD AND REVERSE SWITCH REPLACEMENT

- Disconnect power source to unit.
- Remove 2 1/4 - 20 x 1/2 hexhead bolts from handle. Use 7/16 diameter wrench or socket.
- Loosen 9/16 nut that secures switch to handle.
- Remove handle and switch.
- Remove 2 spade connectors from switch.
- For switch replacement, bend the 2 prongs 90° from both ends of switch. Use old switch as a pattern.

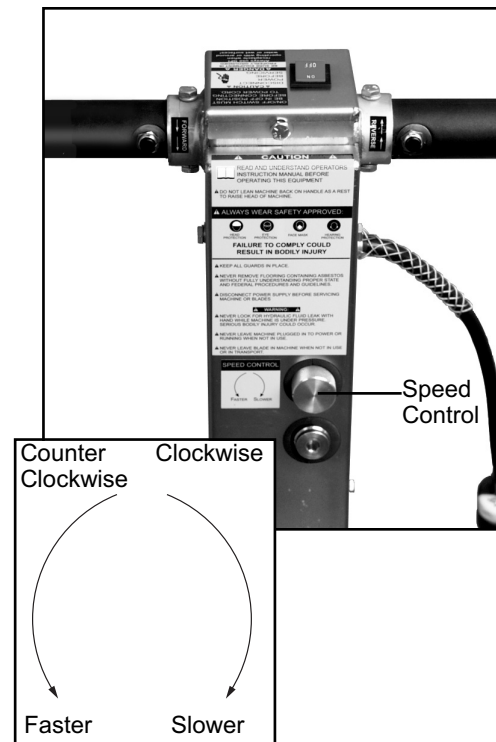

Figure C

BS110 PROCEDURES

FORWARD AND REVERSE SWITCH REPLACEMENT (continued)

- Connect 2 space connectors to 2 bent prongs on switch.
- Install black washer in new switch, and re-install switch in notch in handle. Tighten with a 9/16 wrench or socket. Use care not to strip threads.
- Insert handle into collar on handle column, and replace the 2 1/4 - 20 x 1 1/2 bolts. Tighten bolts with 7/16 wrench.

CARTRIDGE REPLACEMENT

- Disconnect solenoid wires from switches.
- Remove nut on top of solenoid.
- Remove solenoids and spacer.
- Remove cartridge with a 1" wrench.
- Replace with new cartridge.
- Remount solenoids to make sure spacer is in between.
- Re-install nut with lock-tight (do not over Tighten).
- Reconnect solenoid wires.

POWER CORD

- If power cord is damaged, it must be replaced by Blastrac or its service agent, or a similar qualified person in order to avoid a hazard.

ON/OFF SWITCH WIRE DIAGRAM

- 2 power wires go to copper spades
- 2 other wires go to other spades

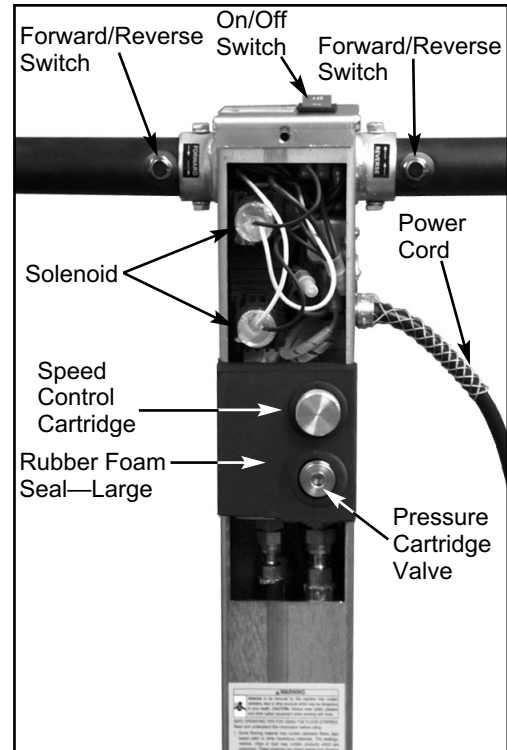

BS110 TROUBLESHOOTING

IF THERE IS NO FORWARD OR REVERSE:

1. Check speed control valve. Turn counterclockwise to open valve.
2. Check wheel pins. Make sure they are in the wheels.
3. Check belt. Remove front cover plate (#6280-145) and inspect.

IF MOTOR SHUTS OFF OR WILL NOT START:

1. Push reset button located on electric box on motor, located on right hand side (See Figure A). See label on motor.

IF WHEELS DO NOT TURN WHEN MACHINE IS UNDER POWER:

1. Make sure axle pins are in place.



Figure A

Note: Number in parenthesis () is the amount needed on each machine. Parts are sold individually therefore order the number of parts needed.

BS110 COMPLETE PARTS LIST

<u>PART #</u>	<u>DESCRIPTION</u>
06-6280-6	PUMP SHAFT KEY (NOT SHOWN)
06-6280-7	TANK MOUNTED STRAINER
06-6280-103	AXLE SHAFT (OLD STYLE)
06-6280-103-1	AXLE SHAFT (NEW STYLE)
06-6280-103A	AXLE SNAP RING (2)
06-6280-104	AXLE SPROCKET WITH KEY
06-6280-105L	AXLE BEARING SUPPORT LEFT
06-6280-105R	AXLE BEARING SUPPORT RIGHT
06-6280-107	BASE PLATE (2" ECCENTRIC HOLE)
06-6280-108	BASE PLATE (2¼" ECCENTRIC HOLE)
06-6280-110	WHEEL SPACER 1/2" (NOT SHOWN)
06-6280-111A	WHEEL KEY (NOT SHOWN)
06-6280-111-2B	WHEEL WITH HUB (NEW STYLE)
06-6280-112	WHEEL CAP (2)
06-6280-113	PUMP NON SPLINE (OLD STYLE)
06-6280-113A	HYDRAULIC PUMP KEY (OLD STYLE) (NOT SHOWN)
06-6280-113S	PUMP SPLINED (NEW STYLE)
06-6280-113-1	SEAL KIT (NOT SHOWN)
06-6280-114B	PUMP DRIVE ASSEMBLY - SPLINED
06-6280-114BN	PUMP DRIVE ASSEMBLY - NON-SPLINED
06-6280-115	PUMP SHEAVE ONLY
06-6280-116	PUMP SHAFT NON SPLINE (OLD STYLE)
06-6280-116A	PUMP SHAFT SPLINED (NEW STYLE)
06-6280-117	PRESSURE HOSE TO PUMP CONNECTOR
06-6280-118	SUCTION HOSE TO PUMP CONNECTOR
06-6280-119	PUMP SPACER
06-6280-120	SUCTION HOSE
06-6280-124	PUMP DRIVE BELT
06-6280-125	IDLER ASSEMBLY COMPLETE (INCLUDES 125A, 126, 126A, 73003,73210, 73218) (NOT SHOWN)
06-6280-125A	IDLER MOUNTING BRACKET & PIN
06-6280-126A	IDLER BEARING CAP
06-6280-129C	ECCENTRIC KEY
06-6280-132	BEARING CUP ONLY (OLD STYLE)
06-6280-132B	CUP BEARING WITH BEARING ASSEMBLY (OLD STYLE)
06-6280-133	CUTTING HEAD VIBRATION ISOLATOR (5)
06-6280-134	CUTTING HEAD (OLD STYLE)
06-6280-135	CUTTING HEAD BEARING ASSEMBLY (OLD STYLE)
06-6280-136	BLADE COVER
06-6280-138	MAIN BOTTOM COVER (NEW STYLE)
06-6280-138E	MAIN BOTTOME COVER (OLD STYLE)
06-6280-139	REAR COVER
06-6280-143	CUTTING HEAD (NEW STYLE)
06-6280-145	FRONT COVER
06-6280-146	FRONT COUNTERWEIGHT
06-6280-147-1	STARTER SWITCH
06-6280-147-3	THERMO OVERLOAD SWITCH
06-6280-148	MOTOR FAN COVER
06-6280-148A	MOTOR FAN COVER SCREW 8-32 X 3/8 HEX WASHER HEAD TORX DR. SS (3)
06-6280-149	MOTOR FAN (NOT SHOWN)
06-6280-150	CAPACITOR COVER
06-6280-150A	CAPACITOR COVER SCREWS (2) (NOT SHOWN)
06-6280-151A	MOTOR CAPACITOR (RUN)
06-6280-151B	MOTOR CAPACITOR (START)
06-6280-152	MOTOR JUNCTION BOX ONLY
06-6280-152-1	MOTOR JUNCTION BOX COVER ONLY

BS110 COMPLETE PARTS LIST

PARTS (continued)

<u>PART #</u>	<u>DESCRIPTION</u>
06-6280-152-2	MOTOR JUNCTION BOX & COVER SECURING SCREW (4/BOX, 2/COVER) (NOT SHOWN)
06-6280-152-3	COVER GASKET ONLY
06-6280-152-4	JUNCTION BOX FRAME GASKET ONLY
06-6280-153L	LEFT UPPER MAIN BODY
06-6280-153R	RIGHT UPPER MAIN BODY
06-6280-155L	LEFT UPPER MAIN BODY (NEW STYLE)
06-6280-161A	FILLER CAP BUSHING ONLY (OLD STYLE)
06-6280-161B	FILLER CAP VENT PLUG ONLY (OLD STYLE)
06-6280-161C	FILLER PORT PLUG ASSEMBLY - TAPERED THREAD (OLD STYLE)
06-6280-161D	FILLER PORT PLUG ASSEMBLY - STRAIGHT THREAD (NEW STYLE)
06-6280-162	HYDRAULIC TANK BODY
06-6280-162E	DRAIN PLUG/OIL LEVEL
06-6280-162G	TANK MAGNET (NOT SHOWN)
06-6280-163	HYDRAULIC TANK COVER (OLD STYLE) (NOT SHOWN)
06-6280-163A	HYDRAULIC TANK COVER GASKET (NOT SHOWN)
06-6280-165	WHEEL CLEANER
06-6280-166B	SWITCH PLATE CAP
06-6280-166C	HANDLE COVER PLATE
06-6280-166D	RUBBER FOAM SEAL, LARGE
06-6280-166E	RUBBER FOAM SEAL, SMALL (2)
06-6280-167	HANDLE BODY
06-6280-167D	HANDLE VIBRATION ISOLATOR (2)
06-6280-168	POWER CORD (NEW STYLE)
06-6280-170	HANDLE BAR (2)
06-6280-170A	HANDLE BAR GRIPS (2)
06-6280-175	HUBBLE TWIST LOCK FEMALE PLUG 110 VOLT (INSIDE HANDLE BODY) (NOT SHOWN)
06-6280-176	HUBBLE TWIST LOCK MALE PLUG 110 VOLT (INSIDE HANDLE BODY)
06-6280-177	3/8 90° CABLE CONNECTOR
06-6280-178	POWER CORD STRAIN RELIEF
06-6280-179	MOTOR SPACER RING
06-6280-180	MOTOR HOSE
06-6280-181	PRESSURE HOSE
06-6280-182	RETURN LINE HOSE
06-6280-206	FORWARD/REVERSE SWITCH (2)
06-6280-206B	SWITCH CAP
06-6280-207	ON/OFF SWITCH 110 VOLT
06-6280-208	SPEED CONTROL CARTRIDGE
06-6280-208A	SPEED CONTROL KNOB ONLY
06-6280-209	PRESSURE CARTRIDGE VALVE
06-6280-212	RETURN LINE
06-6280-214	BLOCK PLUG (NOT SHOWN)
06-6280-215	VALVE BLOCK ASSEMBLY
06-6280-216	SOLENOID VALVE CARTRIDGE
06-6280-217	SOLENOID COILS 110V (2)
06-6280-219	VALVE BODY PLUG (NOT SHOWN)
06-6280-220	HYDRAULIC MOTOR (OLD STYLE)
06-6280-220A	HYDRAULIC MOTOR (NEW STYLE)
06-6280-221	HYDRAULIC MOTOR CONNECTOR (2)
06-6280-223	HYDRAULIC MOTOR SHAFT KEY
06-6280-224	HYDRAULIC MOTOR SPROCKET
06-6280-225	HYDRAULIC MOTOR SPACER
06-6280-226	HYDRAULIC MOTOR MOUNTING BRACKET
06-6280-228	DRIVE CHAIN

BS110 COMPLETE PARTS LIST

PARTS (continued)

<u>PART #</u>	<u>DESCRIPTION</u>
06-6280-229	DRIVE CHAIN MASTER LINK ASSEMBLY
06-6280-230	SIDE COUNTERWEIGHT RIGHT
06-6280-231	SIDE COUNTERWEIGHT LEFT
06-6280-304	DRAIN HOSE
06-6280-400	ECCENTRIC ONLY (NEED KEY & SET SCREWS) (OLD STYLE)
06-6280-400A	ECCENTRIC ASSEMBLY COMPLETE (OLD STYLE) (INCLUDES 129C, 400, 73010, 73012 [2]) (NOT SHOWN)
06-6280-401	BLADE SOCKET HEXHEAD WRENCH (OLD STYLE)
06-6280-401B	BLADE ALLEN BUTTON HEAD WRENCH (NEW STYLE)
06-6280-404	BLADE WRENCH HOLDER
06-6280-405	ECCENTRIC ONLY, NEED KEY & SET SCREWS (NEW STYLE)
06-6280-405A	ECCENTRIC ASSEMBLY COMPLETE (NEW STYLE) (INCLUDES 131, 405,73010, 72012 [2]) (NOT SHOWN)
06-6280-1151	PUMP SHEAVE RETAINER ONLY
06-6280-1152A	PUMP SHAFT SNAP RING
06-6280HD-131	ECCENTRIC KEY
06-6280HD-146	FRONT COUNTERWEIGHT
06-62504	FILLER PORT "O" RING (OLD STYLE)
06-71072	IDLER BEARING (2)
06-71093	CUP BEARING (OLD STYLE)
06-71113	WHEEL BEARING (NEW STYLE) (NOT SHOWN)
06-71115	1 X 2 X 1/2 BEARING (AXLE-2, PUMP DRIVE-1, HYD MOTOR-1, ECCENTRIC-1)
06-71118	FLANGE BEARING
06-71132	ECCENTRIC BEARING
06-71141	CUTTING HEAD BEARING ASSEMBLY 1-7/16 (NEW STYLE)
06-72364	MOTOR 115 VOLT (OLD STYLE, 7/8" SHAFT)
06-72365	MOTOR 115 VOLT (NEW STYLE, 1-1/8" SHAFT)
06-72367W	MOTOR 230 VOLT, 1.5 HP (NEW STYLE)
06-72368W	MOTOR 220 VOLT, 1.5 HP (OLD STYLE) (#115753)
06-72816	RETURN LINE ELBOW
06-73002	1/4 SPLIT LOCK WASHER (PUMP DRIVE ASSEMBLY-3, REAR VIEW EXTERNAL-13 [NOT SHOWN], HANDLE-10)
06-73003	1/4-20 X 5/8 BUTTON HEAD CAP SCREW
06-73005	1/4-20 X 1/2 HEXHEAD BOLT (4)
06-73008	1/4-20 NYLON LOCK NUT (OLD STYLE) (4)
06-73010	1/4-20 X 1/4 SET SCREW (ECCENTRIC ASSEMBLY-1, AXLE ASSEMBLY-1)
06-73012	1/4-20 X 3/8 SET SCREW (ECCENTRIC ASSEMBLY-2, AXLE ASSEMBLY-1)
06-73015	1/4-20 X 1-3/8 HEXHEAD BOLT, GRADE 5 (3)
06-73019	1/4-20 X 3/4 HEXHEAD BOLT (4)
06-73020	1/4-20 X 5/8 WIZLOCK BOLT (EXTERNAL PARTS-8, BODY PARTS-2)
06-73022	1/4-28 X 1/2 HEXHEAD BOLT, GRADE 5 (REAR VIEW EXTERNAL-8, HANDLE-8)
06-73024	1/4-20 X 5/8 LOW HEAD CAP SCREW (8) (OLD STYLE) (NOT SHOWN)
06-73033	1/4 X 1/4 X 1 KEY
06-73101	1/8 SPACER
06-73201	3/8-16 X 1 HEXHEAD BOLT, GRADE 5 (BASE PLATE-4, WHEEL CLEANER-1,)
06-73203	3/8 FLAT WASHER (EXTERNAL PARTS-4 [NOT SHOWN], BOTTOM COVER -2, WHEEL CLEANER-2, BODY PARTS-1 [NOT SHOWN], INTERNAL-3)
06-73204	3/8 SPLIT WASHER (EXTERNAL PARTS-4 [NOT SHOWN], BASE PLATE-4, WHEEL CLEANER-3, INTERNAL-3)
06-73206	3/8-16 X 1-1/4 HEXHEAD BOLT, GRADE 8 (REAR VIEW EXTERNAL: NEW STYLE-6 OLD STYLE-4, INTERNAL-3)
06-73210	3/8 EXTERNAL LOCK WASHER
06-73211	3/8-16 WIZLOCK NUT (BASE PLATE-5, BOTTOM COVER-2)
06-73213	3/8-16 X 3/4 BUTTON HEAD CAP SCREW (5) (NEW STYLE) (NOT SHOWN)
06-73217	3/8-16 X 3/4 HEXHEAD BOLT (EXTERNAL PARTS-5 [OLD STYLE], BASE PLATE-5)
06-73218	3/8-24 X 3/4 HEXHEAD BOLT, GRADE 5
06-73221	3/8-16 X 2-3/4 HEXHEAD BOLT (4)
06-73222	3/8-16 X 1 WIZLOCK BOLT (MOTOR PARTS-2, INTERNAL PARTS-4)

BS110 COMPLETE PARTS LIST

PARTS (continued)

<u>PART #</u>	<u>DESCRIPTION</u>
06-73223	3/8-16 X 1-1/4 WIZLOCK BOLT (MOTOR PARTS-2, INTERNAL PARTS-2)
06-73224	3/8-16 X 1/2 WIZLOCK BOLT (4)
06-73226	3/8-24 X 1 HEXHEAD BOLT (4)
06-73228	3/8-16 X 8 EYEBOLT (2)
06-73235	3/8-24 JAMB NUT (4) (NOT SHOWN)
06-73242	3/8-16 X 1 BUTTON HEAD CAP SCREW W/ FLANGE (NEW STYLE) (5)
06-73245	3/8-16 X 1½ WIZLOCK FLANGE BOLT (2)
06-73301	5/16-18 X 1/2 BUTTON HEAD CAP SCREW (3) (NOT SHOWN)
06-73304	5/16 WAVEY WASHER (2)
06-73309	5/16-18 X 3/4 SOCKET HEAD CAP SCREW (4)
06-73310	5/16-18 X 7/8 SOCKET HEAD CAP SCREW, RIGHT, GRADE 5 (2)
06-73311	5/16-18 X 1 SOCKET HEAD CAP SCREW, LEFT, GRADE 5 (2)
06-73313	5/16-18 X 1/2 SOCKET HEAD CAP SCREW (NEW STYLE) (2)
06-73315	5/16-18 X 1 FLAT HEAD ALLEN SCREW (OLD STYLE) (2)
06-73330	5/16 X 2 PIN
06-73332	5/16 X 18-5/8 HEXHEAD CAP BOLT (2)
06-74402	10-32 X 3/8 CUP POINT SET SCREW (SPEED CONTROL) (NOT SHOWN)

ACCESSORIES

<u>PART #</u>	<u>DESCRIPTION</u>
06-6251	LOADING RAMP
06-6251-1	REPLACEMENT PINCH POINT GUARD (SET)
06-6254	50' 12 GAUGE POWER CORD
06-6254-1	FEMALE CONNECTOR ONLY, 4729C
06-6254-2	MALE PLUG ONLY, 5266C
06-6280-1	HYDRAULIC FLUID, GALLON (NOT SHOWN)
06-6280-146A	ADDITIONAL FRONT WEIGHT
06-6280-299	FRONT TRANSPORT WHEEL ASSEMBLY
06-6280-300	TRANSPORT WHEEL BRACKET (NOT SHOWN)
06-6280-301	FRONT TRANSPORT WHEEL ONLY
06-6280-500	SWIVEL HEAD ATTACHMENT
06-6280-502	OPTIONAL SADDLE WEIGHT
06-73219	3/8-16 X 5 HEXHEAD BOLT (FOR 2 ADDITIONAL WEIGHTS)
06-73220	3/8-16 X 3 HEXHEAD BOLT (FOR 1 ADDITIONAL WEIGHT)

BLADES

<u>PART #</u>	<u>DESCRIPTION</u>
06-130-S	3" X 10" BLADE WITH SLOTS
06-130-D	3" X 10" DOUBLE EDGE BLADE
06-131-S	3" X 16" BLADE WITH SLOTS
06-135	5" X 16" BLADE
06-136	5" X 8" BLADE
06-147	4" X 6" BLADE
06-147-D	4" X 6" DOUBLE EDGE BLADE
06-148	5" X 6" BLADE
06-148-D	5" X 6" DOUBLE EDGE BLADE
06-363-2	3/4" X 8" SCRAPER BLADE (50/PKG)
06-368-8	7/8" X 8" RAZOR/SCRAPER BLADE (50/PKG)
06-368-12	7/8" X 12" RAZOR/SCRAPER BLADE (50/PKG)
06-368-15	7/8" X 15" RAZOR/SCRAPER BLADE (50/PKG)

BS110 COMPLETE PARTS LIST

BLADES (continued)

<u>PART #</u>	<u>DESCRIPTION</u>
06-6253	PANTHER RIPPER TEETH
06-6255-BU	4" X 6" SELF SCORING BLADE
06-6257-BU	3" X 9" SELF SCORING BLADE
06-6258-BU	3" X 12" SELF SCORING BLADE
06-6259-BU	3" X 14" SELF SCORING BLADE
06-6277-BU	3" X 12" SELF SCORING BLADE
06-6278-BU	3" X 14" SELF SCORING BLADE
06-6270	1-1/2" X 3" EXTRA HEAVY DUTY BLADE
06-6271	3" X 6" EXTRA HEAVY DUTY BLADE
06-6273	3" X 11" EXTRA HEAVY DUTY BLADE
06-6280-500	SWIVEL HEAD ATTACHMENT
06-6281	3" X 8" HEAVY DUTY BLADE
06-6282	3" X 14" HEAVY DUTY BLADE
06-6284	3" X 12" HEAVY DUTY BLADE
06-6285	3" X 6" HEAVY DUTY BLADE
06-6286	3" X 10" HEAVY DUTY BLADE
06-6290	3" X 6" EXTRA HEAVY DUTY BLADE
06-6291	3" X 8" EXTRA HEAVY DUTY BLADE
06-6292	3" X 12" EXTRA HEAVY DUTY BLADE
06-6293	3" X 14" EXTRA HEAVY DUTY BLADE
06-7050-200	3" X 6" PREMIUM HIGH TEMP BLADE
06-7050-201	3" X 8" PREMIUM HIGH TEMP BLADE
06-7050-202	3" X 10" PREMIUM HIGH TEMP BLADE
06-7050-203	3" X 12" PREMIUM HIGH TEMP BLADE
06-7050-204	3" X 14" PREMIUM HIGH TEMP BLADE
06-7080	3" X 8" INCREASED ANGLE BLADE
06-7081	3" X 10" INCREASED ANGLE BLADE

LABELS

<u>PART #</u>	<u>DESCRIPTION</u>
06-L37	CAUTION SHARP BLADE LABEL (2)
06-L49	POWER CORD LABEL
06-L95B	ON/OFF SWITCH LABEL
06-L95C	FORWARD LABEL
06-L95D	REVERSE LABEL
06-L95E	SPEED CONTROL LABEL
06-L95F	WARNING FLUID LEAK LABEL
06-L95G	FLUID LEVEL LABEL
06-L95H	CAUTION DO NOT RUN LABEL
06-L95J	110 VOLT LABEL (NOT SHOWN)
06-L95K	RAMP LABEL (2)
06-L95L	REMOVE COUNTERWEIGHTS LABEL
06-L141	MADE IN USA LABEL
06-L170	BLASTRAC LABEL (2)
06-L170B	BLASTRAC STOCK NUMBER LABEL
06-L188	CAUTION GENERAL INFO LABEL
06-L189	SAFE OPERATING TIPS LABEL
06-L223	PATENT NUMBER LABEL

BS110 PART NUMBERS & DIAGRAMS

EXTERNAL PARTS

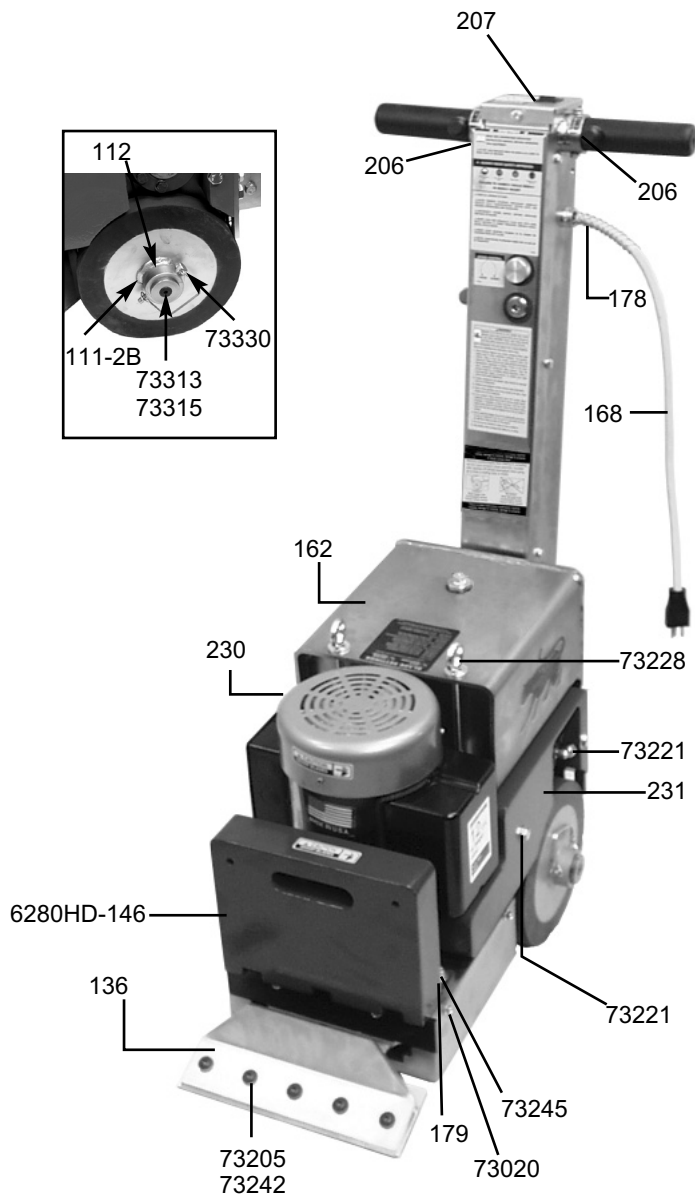

<u>PART #</u>	<u>DESCRIPTION</u>
06-6280-110	Wheel Spacer (Not Shown)
06-6280-111A	Wheel Key (Not Shown)
06-6280-111-2B	Wheel with Hub (New Style)
06-6280-112	Wheel Cap (2)
06-6280-136	Blade Cover
06-6280-162	Hydraulic Tank Body
06-6280-162G	Tank Magnet (Not Shown)
06-6280-163	Hydraulic Tank Cover (Old Style) (Not Shown)
06-6280-168	Power Cord (New Style)
06-6280-178	Power Cord Strain Relief
06-6280-179	Motor Spacer Ring
06-6280-206	Forward/Reverse Switch (2)
06-6280-207	On/Off Switch 110 Volt
06-6280-230	Side Counterweight Right
06-6280-231	Side Counterweight Left
06-6280HD-146	Front Counterweight
06-71113	Wheel Bearing (New Style) (Not Shown)
06-73020	1/4-20 x 5/8 Wizlock Bolt (8)
06-73024	1/4-20 x 5/8 Low Head Cap Screw (Old Style) (8) (Not Shown)
06-73203	3/8 Flat Washer (4) (Not Shown)
06-73204	3/8 Split Washer (4) (Not Shown)
06-73205	3/8-16 x 3/4 Hexhead Bolt (Old Style) (5)
06-73213	3/8-16 x 3/4 Button Head Cap Screw (New Style) (5) (Not Shown)
06-73221	3/8-16 x 2-3/4 Hexhead Bolt (4)
06-73228	3/8-16 x 8 Eyebolt (2)
06-73242	3/8-16 x 1 Button Head Cap Screw w/ Flange (New Style) (5)
06-73245	3/8-16 x 1 1/2 Wizlock Bolt (2)
06-73313	5/16-18 x 1/2 Flat Head Socket Cap Screw (New Style) (2)
06-73315	5/16-18 x 1 Flat Head Allen Screw (Old Style) (2)
06-73330	5/16 x 2 Pin

BS110 PART NUMBERS & DIAGRAMS

REAR VIEW EXTERNAL PARTS

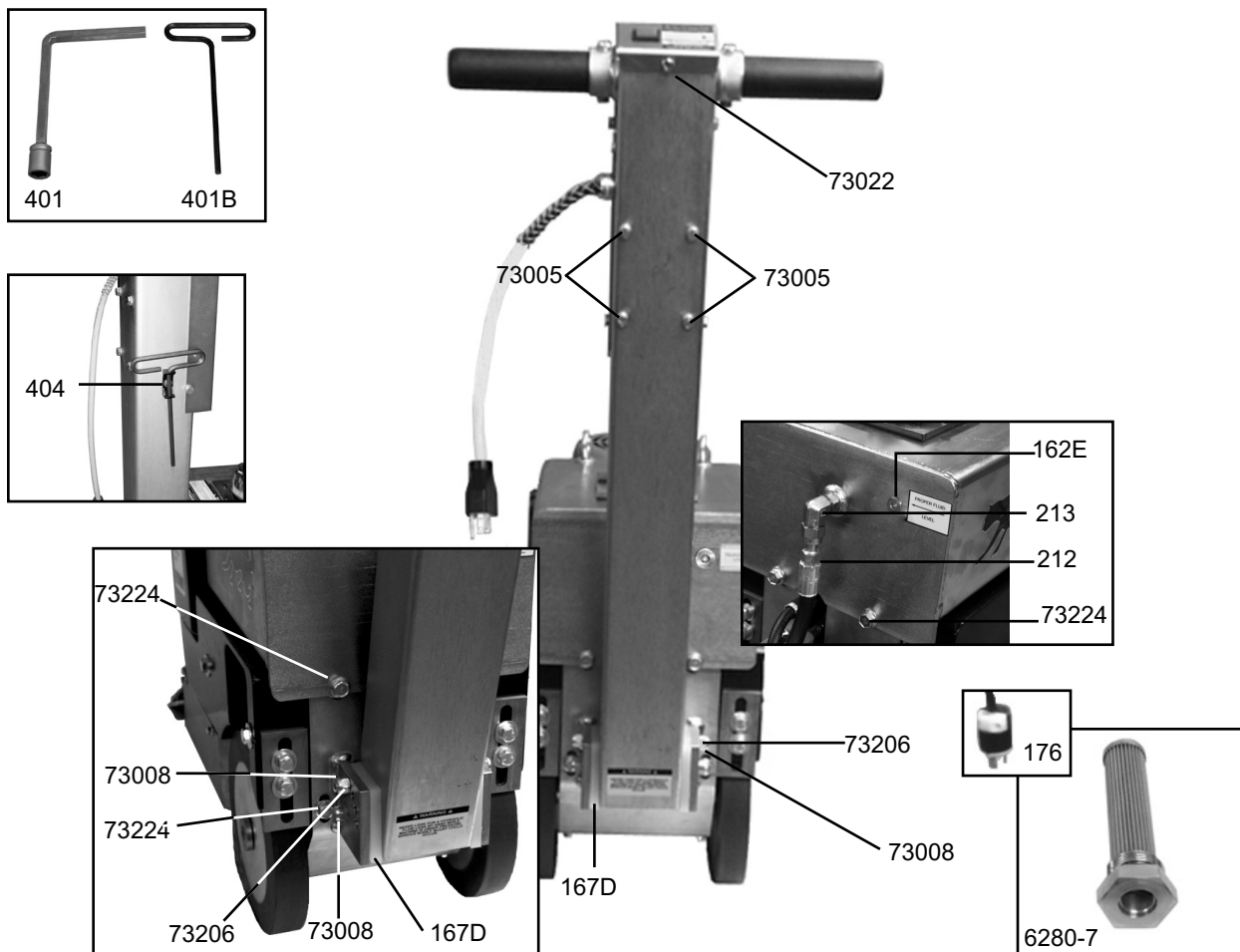

PART #	DESCRIPTION	PART #	DESCRIPTION
06-6280-7	Tank Mounted Strainer	06-6280-401B	Blade Allen Button Head Wrench (New Style)
06-6280-162E	Drain Plug/Oil Level	06-6280-404	Blade Wrench Holder
06-6280-163A	Hydraulic Tank Cover Gasket (Not Shown)	06-72816	Return Line Elbow
06-6280-167D	Handle Vibration Isolator (2)	06-73002	1/4 Split Lock Washer (13) (Not Shown)
06-6280-175	Hubble Twist Lock Female Plug 110V (Inside Handle Body) (Not Shown)	06-73005	1/4-20 x 1/2 Hexhead Bolt (4)
06-6280-176	Hubble Twist Lock Male Plug 110V (Inside Handle Body)	06-73008	1/4-20 Nylon Lock Nut (Old Style) (4)
06-6280-212	Return Line	06-73022	1/4-28 x 1/2 Hexhead Bolt, Grade 5 (8)
06-6280-401	Blade Socket Hexhead Wrench (Old Style)	06-73206	3/8-16 x 1-1/4 Hexhead Bolt, Grade 8 New Style (6) Old Style (4)
		06-73224	3/8-16 x 1/2 Wizlock Bolt (4)

BS110 PART NUMBERS & DIAGRAMS

BASE PLATE PARTS

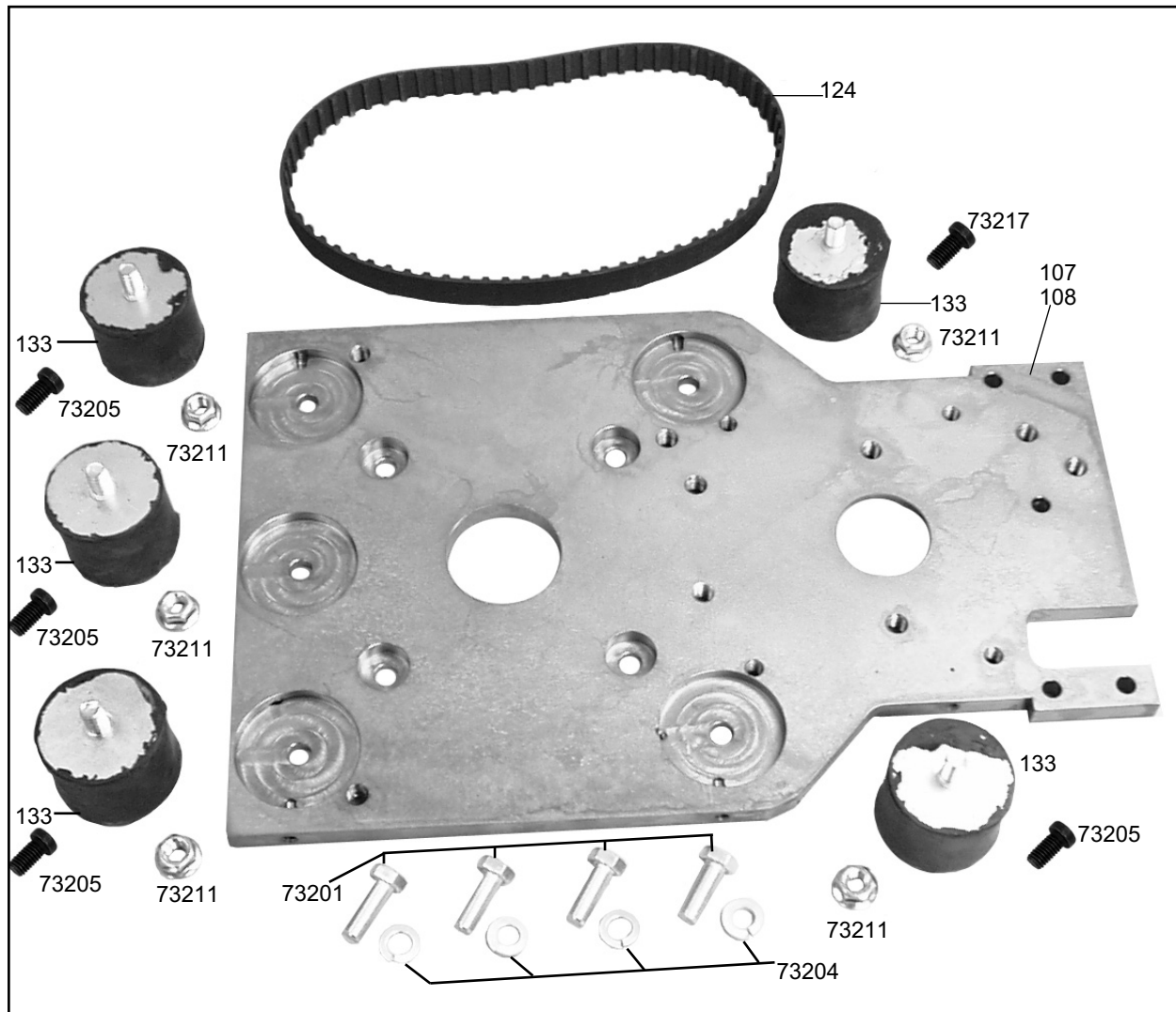

<u>PART #</u>	<u>DESCRIPTION</u>	<u>PART #</u>	<u>DESCRIPTION</u>
06-6280-107	Base Plate (2" Eccentric Hole)	06-73204	3/8 Split Lock Washer (4)
06-6280-108	Base Plate (2 1/4" Eccentric Hole)	06-73217	3/8-16 x 3/4 Lowhead Socket Bolt (5)
06-6280-124	Pump Drive Belt	06-73211	3/8-16 Wizlock Nut (5)
06-6280-133	Cutting Head Vibration Isolator (5)		
06-73201	3/8-16 x 1 Hexhead Bolt, Grade 5(4)		

BS110 PART NUMBERS & DIAGRAMS

IDLER ASSEMBLY PARTS

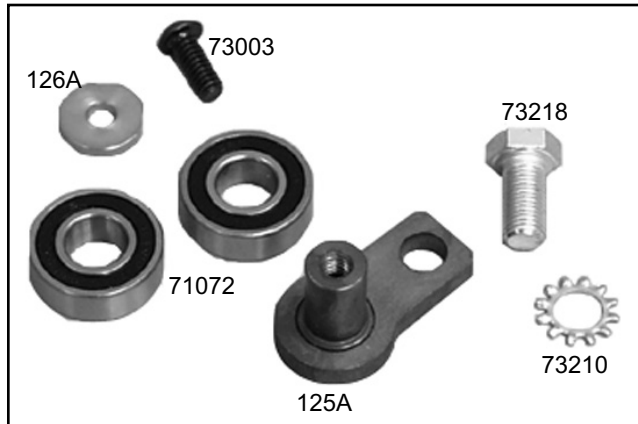

<u>PART #</u>	<u>DESCRIPTION</u>
06-6280-125	Idler Assembly Complete (Includes 125A, 126, 126A, 73003, 73218, 73210) (Not Shown)
06-6280-125A	Idler Mounting Bracket & Pin
06-6280-126A	Idler Bearing Cap
06-71072	Idler Bearing (2)
06-73003	1/4-20 x 5/8 Button Head Cap Screw
06-73210	3/8 External Lock Washer
06-73218	3/8-24 x 3/4 Hexhead Bolt, Grade 5

PUMP DRIVE ASSEMBLY PARTS

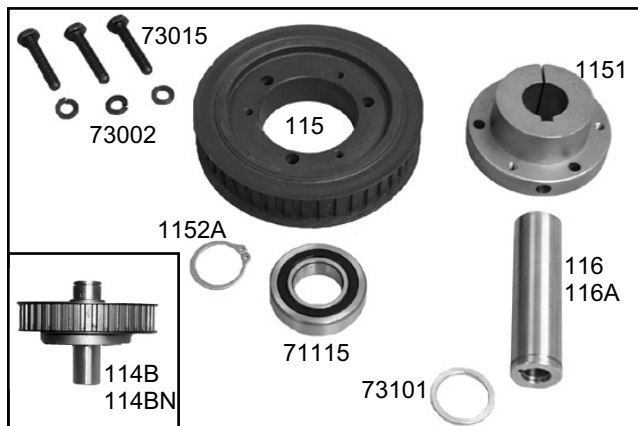

<u>PART #</u>	<u>DESCRIPTION</u>
06-6280-6	Pump Shaft Key (Not Shown)
06-6280-114B	Pump Drive Assembly- Splined
06-6280-114BN	Pump Drive Assembly- Non-Splined
06-6280-115	Pump Sheave Only
06-6280-116	Pump Shaft Non Spline (Old Style)
06-6280-116A	Pump Shaft Splined (New Style)
06-6280-1151	Pump Sheave Retainer Only
06-6280-1152A	Pump Shaft Snap Ring
06-71115	1 x 2 x 1/2 Bearing
06-73101	1/8 Spacer
06-73002	1/4 Split Lock Washer (3)
06-73015	1/4-20 x 1-3/8 Hexhead Bolt, Grade 5 (3)

ECCENTRIC ASSEMBLY PARTS

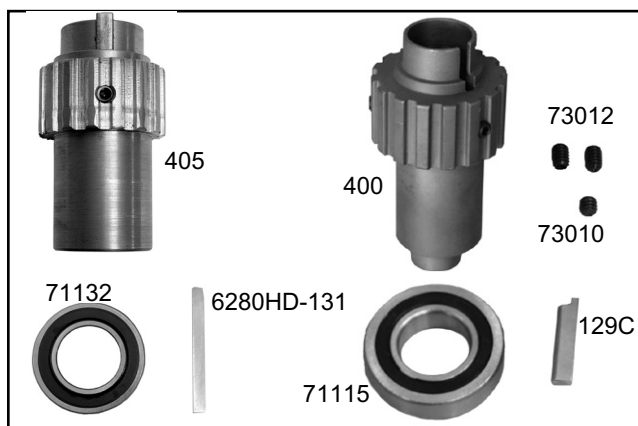

<u>PART #</u>	<u>DESCRIPTION</u>
06-6280-129C	Eccentric Key
06-6280-400	Eccentric Only, Need Key & Set Screws (Old Style)
06-6280-400A	Eccentric Assembly Complete (Old Style) (Includes 129C, 400, 73010, 73012 [2]) (Not Shown)
06-6280-405	Eccentric Only, Need Key & Set Screws (New Style)
06-6280-405A	Eccentric Assembly Complete (New Style) (Includes 131, 405, 73010, 72012 [2])(Not Shown)
06-71132	Eccentric Bearing
06-71115	Eccentric Bearing
06-6280HD-131	Eccentric Key
06-73010	1/4-20 x 1/4 Set Screw
06-73012	1/4-20 x 3/8 Set Screw (2)

BS110 PART NUMBERS & DIAGRAMS

BEARING & BOTTOM COVER PARTS

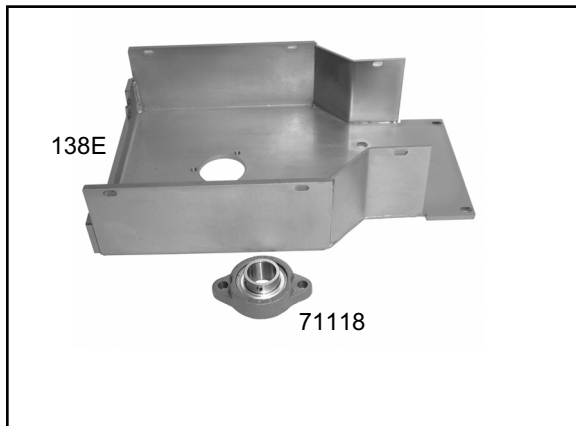
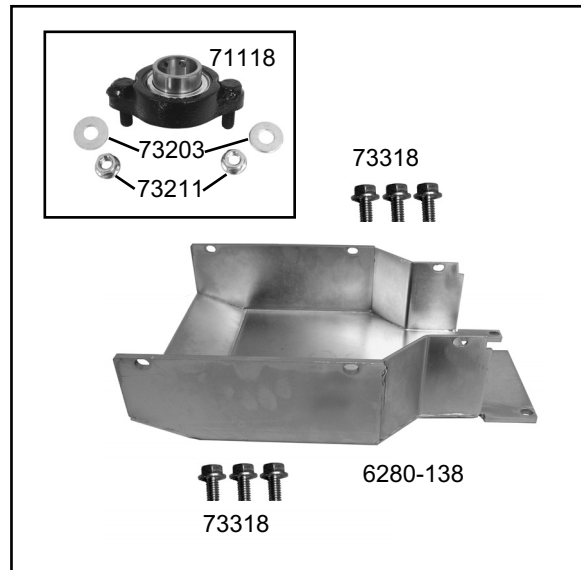
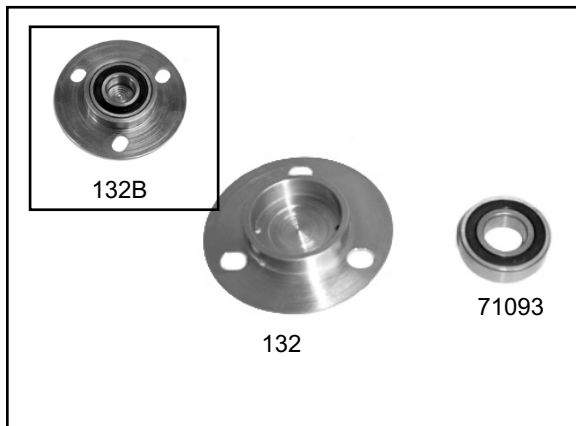

<u>PART #</u>	<u>DESCRIPTION</u>
06-6280-132	Bearing Cup Only (Old Style)
06-6280-132B	Cup Bearing w/Bearing Assembly (Old Style)
06-6280-138	Main Bottom Cover (New Style)
06-6280-138E	Main Bottom Cover (Old Style)
06-71093	Cup Bearing (Old Style)

<u>PART #</u>	<u>DESCRIPTION</u>
06-71118	Flange Bearing
06-73203	3/8 Flat Washer (2)
06-73211	3/8-16 Wizlock Nut (2)
06-73301	5/16-18 x 1/2 Button Head Cap Screw (3) (Not Shown)
06-73318	5/16-18 x 5/8 Wizlock Bolt (Bottom Cover) (6)

BS110 PART NUMBERS & DIAGRAMS

AXLE ASSEMBLY PARTS



<u>PART #</u>	<u>DESCRIPTION</u>
06-6280-103	Axle Shaft (Old Style)
06-6280-103-1	Axle Shaft (New Style)
06-6280-103A	Axle Snap Ring (2)
06-6280-104	Axle Sprocket with Key
06-6280-105L	Axle Bearing Support Left
06-6280-105R	Axle Bearing Support Right
06-71115	1 x 2 x 1/2 Bearing (2)
06-73010	1/4-20 x 1/4 Set Screw
06-73012	1/4-20 x 3/8 Set Screw
06-73033	1/4 x 1/4 x 1 Key
06-73310	5/16-18 x 7/8 Socket Head Cap Screw, Right, Grade 5(2)
06-73311	5/16-18 x 1 Socket Head Cap Screw, Left, Grade 5 (2)

WHEEL CLEANER PARTS

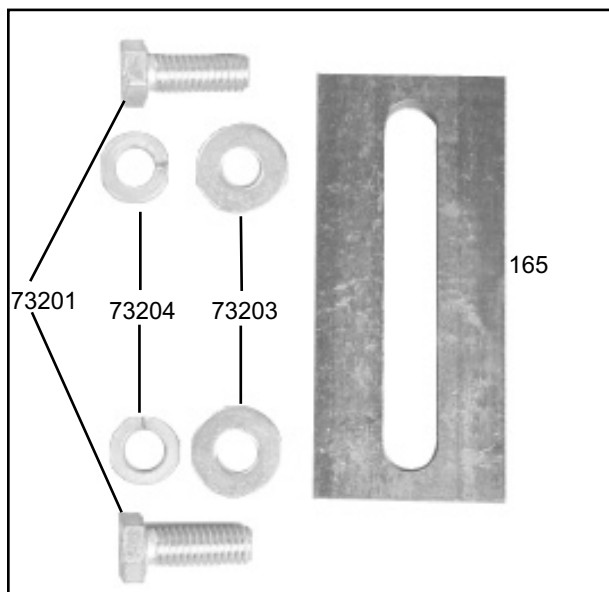

<u>PART #</u>	<u>DESCRIPTION</u>
06-6280-165	Wheel Cleaner
06-73201	Wheel Cleaner Hexhead Bolt 3/8-16 X 1, Grade 5 (2)
06-73203	3/8 Flat Washer (2)
06-73204	3/8 Split Washer (2)

BS110 PART NUMBERS & DIAGRAMS

INTERNAL HANDLE PARTS

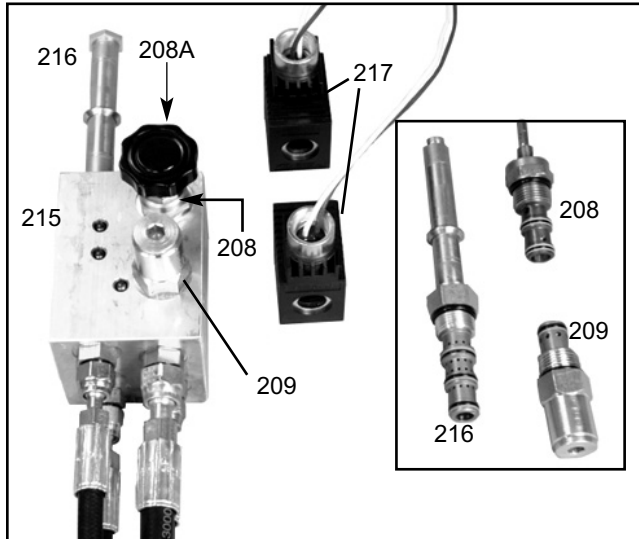

HOSE PARTS

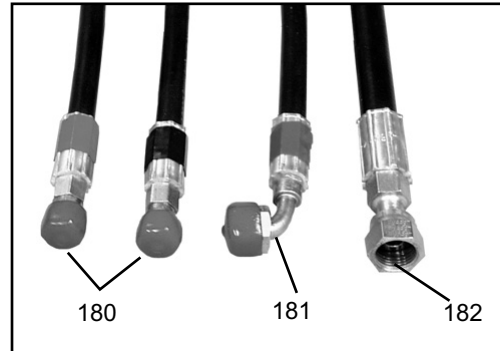

HANDLE PARTS

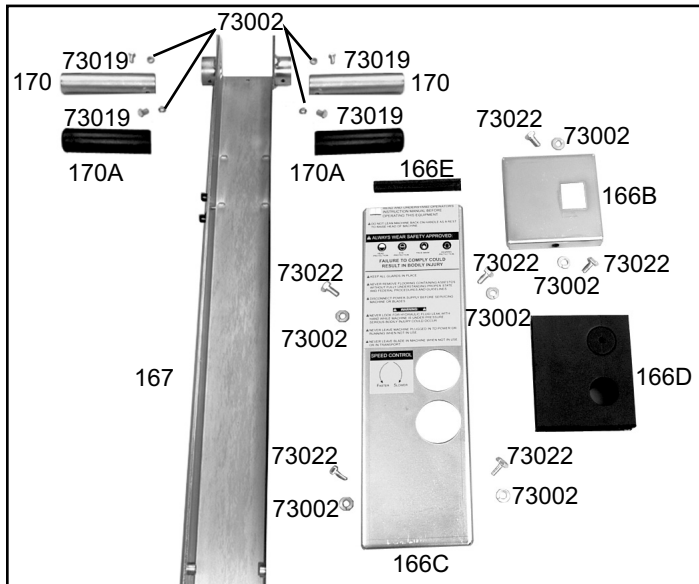

<u>PART #</u>	<u>DESCRIPTION</u>
06-6280-166B	Switch Plate Cap
06-6280-166C	Handle Cover Plate
06-6280-166D	Rubber Foam Seal, Large
06-6280-166E	Rubber Foam Seal, Small
06-6280-167	Handle Body
06-6280-170	Handle Bar (2)
06-6280-170A	Handle Bar Grips (2)
06-6280-180	Motor Hose
06-6280-181	Pressure Hose
06-6280-182	Return Line Hose
06-6280-208	Speed Control Cartridge
06-6280-208A	Speed Control Knob Only
06-6280-209	Pressure Cartridge Valve
06-6280-214	Block Plug (Not Shown)
06-6280-215	Valve Block Assembly
06-6280-216	Solenoid Valve Cartridge
06-6280-217	Solenoid Coils 110V (2)
06-6280-219	Valve Body Plug (Not Shown)
06-73002	1/4 Split Washer (10)
06-73019	1/4-20 x 3/4 Hexhead Bolt (4)
06-73022	1/4-28 x 1/2 Hexhead Bolt, Grade 5 (8)
06-74402	10-32 x 3/8 Cup Point Set Screw (Speed Control) (Not Shown)

BS110 PART NUMBERS & DIAGRAMS

MOTOR PARTS

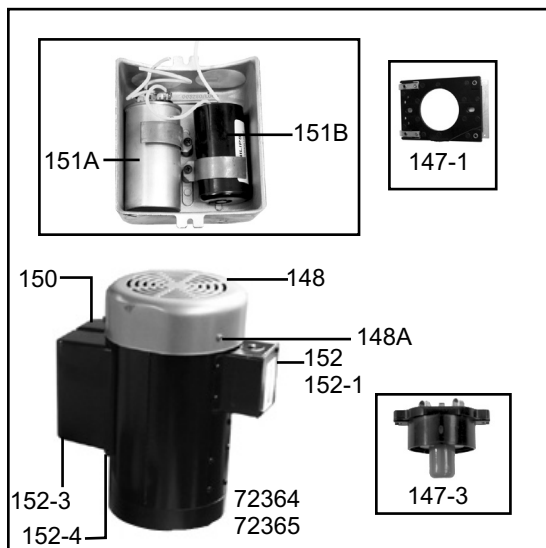

BODY PARTS

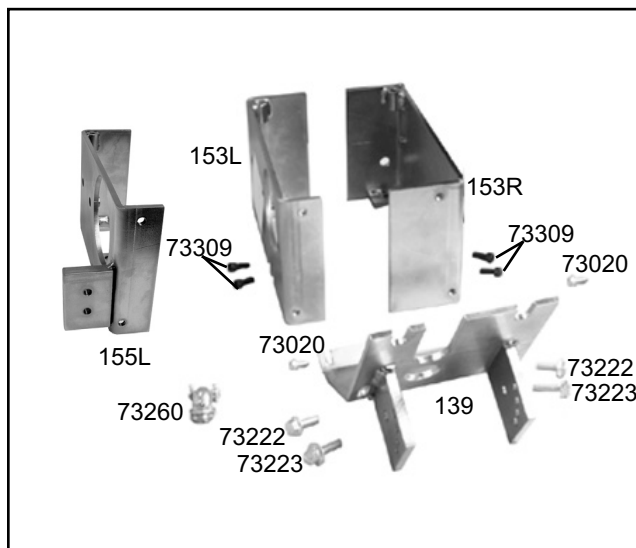

<u>PART #</u>	<u>DESCRIPTION</u>	<u>PART #</u>	<u>DESCRIPTION</u>
06-6280-139	Rear Cover	06-6280-152-4	Junction Box Frame Gasket Only
06-6280-147-1	Starter Switch	06-6280-153L	Left Upper Main Body
06-6280-147-3	Thermo Overload Switch	06-6280-153R	Right Upper Main Body
06-6280-148	Motor Fan Cover	06-6280-155L	Left Upper Main Body (New Style)
06-6280-148A	Motor Fan Cover Screw 8-32 x 3/8 Hex Washer Head Torx Dr. SS (3)	06-72364	Motor 115 Volt (Old Style, 7/8" Shaft) (#115919)
06-6280-149	Motor Fan (Not Shown)	06-72365	Motor 115 Volt (New Style, 1-1/8" Shaft) (#116944)
06-6280-150	Capacitor Cover	06-72367W	Motor 230 Volt, 1.5 HP (New Style)
06-6280-150A	Capacitor Cover Screws (2) (Not Shown)	06-72368W	Motor 220 Volt, 1.5 HP (Old Style) (#115753)
06-6280-151A	Motor Capacitor (Run)	06-73020	1/4-20 x 5/8 Wizlock Bolt (2)
06-6280-151B	Motor Capacitor (Start)	06-73203	3/8 Flat Washer (Not Shown)
06-6280-152	Motor Junction Box Only	06-73222	3/8-16 x 1 Wizlock Bolt (2)
06-6280-152-1	Motor Junction Box Cover Only	06-73223	3/8-16 x 1-1/4 Wizlock Bolt (2)
06-6280-152-2	Motor Junction Box & Cover Securing Screw (4/box, 2/cover) (Not Shown)	06-73260	3/8 90° Cable Connector
06-6280-152-3	Cover Gasket Only	06-73309	5/16-18 x 3/4 Socket Head Cap Screw (4)

BS110 PART NUMBERS & DIAGRAMS

SWITCH PARTS

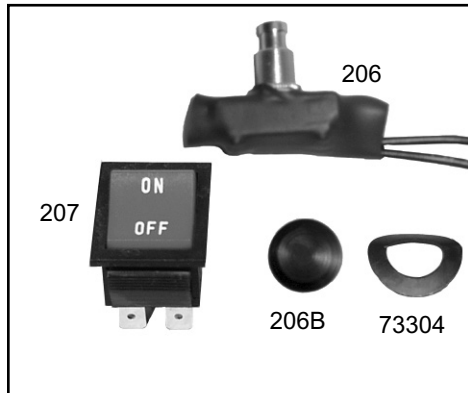

CUTTING HEAD PARTS

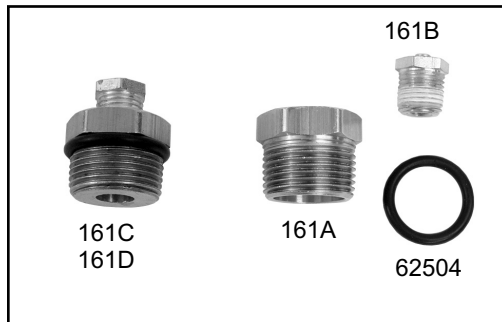
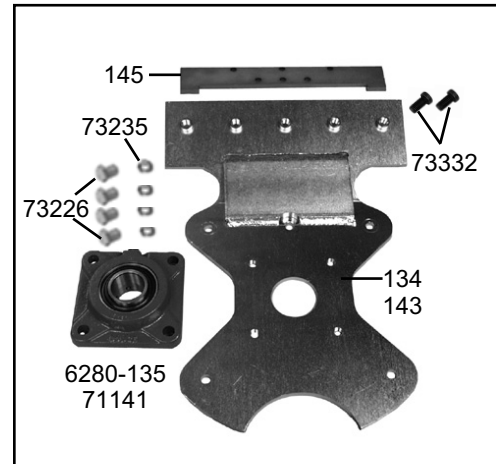

PART #	DESCRIPTION
06-6280-134	Cutting Head (Old Style)
06-6280-135	Cutting Head Bearing Assembly (Old Style)
06-6280-143	Cutting Head (New Style)
06-6280-145	Front Cover
06-6280-161A	Filler Cap Bushing Only (Old Style)
06-6280-161B	Filler Cap Vent Plug Only
06-6280-161C	Filler Port Plug Assembly-Tapered Thread (Old Style)
06-6280-161D	Filler Port Plug Assembly-Straight Thread (New Style)

PART #	DESCRIPTION
06-6280-206	Forward/Reverse Switch (2)
06-6280-206B	Switch Cap
06-6280-207	On/Off Switch 110 Volt
06-62504	Filler Port "O" Ring (Old Style)
06-71141	1-7/16 Cutting Head Bearing Assembly (New Style)
06-73332	5/16 x 18-5/8 Hexhead Bolt (2)
06-73226	3/8-24 x 1 Hexhead Bolt (4)
06-73235	3/8-24 Jamb Nut (4)
06-73304	5/16 Wavy Washer (2)

BS110 PART NUMBERS & DIAGRAMS

INTERNAL PARTS

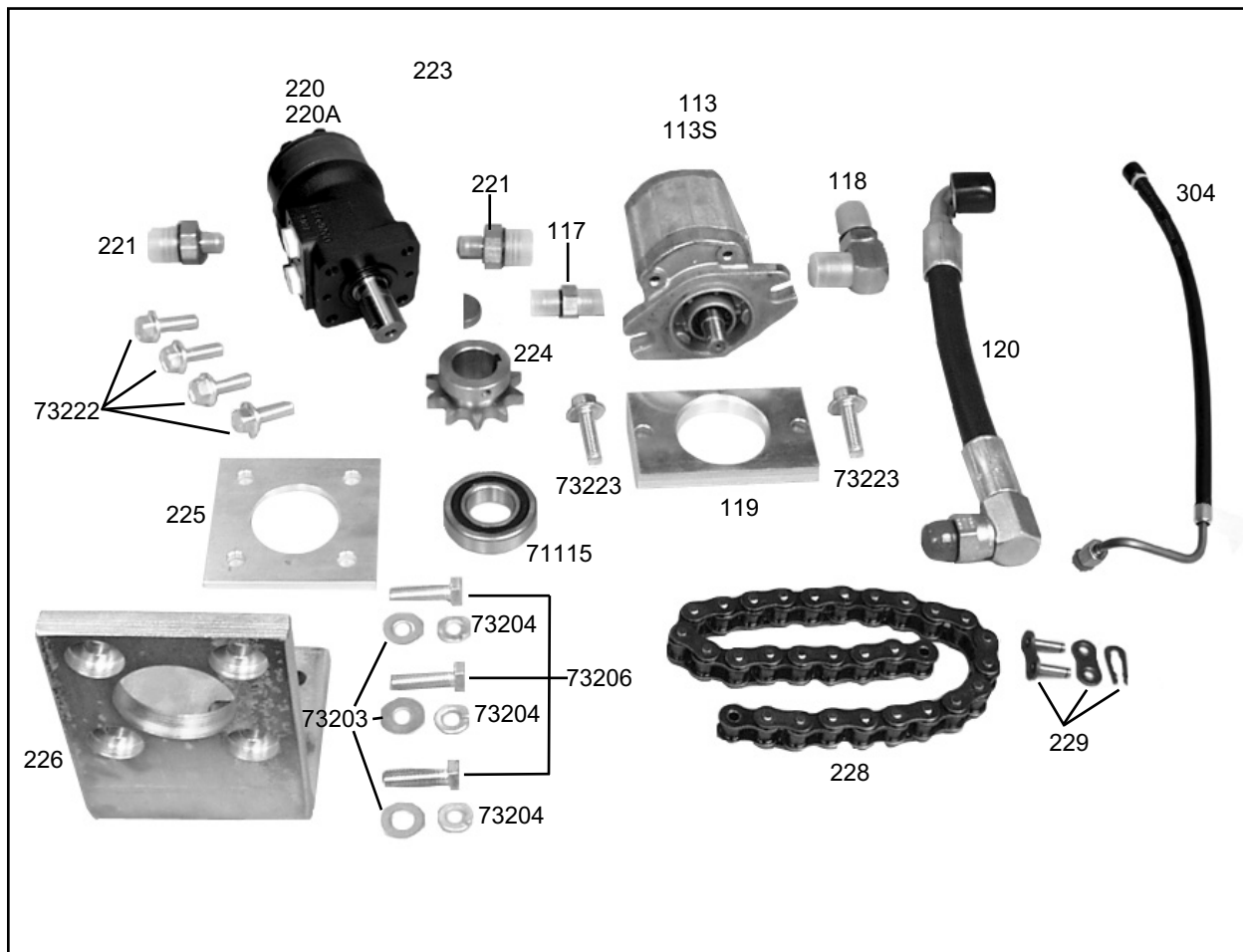

<u>PART #</u>	<u>DESCRIPTION</u>	<u>PART #</u>	<u>DESCRIPTION</u>
06-6280-113	Pump Non Splined (Old Style)	06-6280-225	Hydraulic Motor Spacer
06-6280-113A	Hydraulic Pump Key (Old Style) (Not Shown)	06-6280-226	Hydraulic Motor Mounting Bracket
06-6280-113S	Pump Splined (New Style)	06-6280-228	Drive Chain
06-6280-113-1	Seal Kit (Not Shown)	06-6280-229	Drive Chain Master Link Assembly
06-6280-117	Pressure Hose to Pump Connector	06-6280-304	Drain Hose
06-6280-118	Suction Hose to Pump Connector	06-71115	1 x 2 x 1/2 Bearing
06-6280-119	Pump Spacer	06-73203	3/8 Flat Washer (3)
06-6280-120	Suction Hose	06-73204	3/8 Split Washer (3)
06-6280-220	Hydraulic Motor (Old Style)	06-73206	3/8-16 x 1-1/4 Hexhead Bolt (3)
06-6280-220A	Hydraulic Motor (New Style)	06-73222	3/8-16 x 1 Wizlock Bolt (4)
06-6280-221	Hydraulic Motor Connector (2)	06-73223	3/8-16 x 1-1/4 Wizlock Bolt (2)
06-6280-223	Hydraulic Motor Shaft Key		
06-6280-224	Hydraulic Motor Sprocket		

BS110 LABELS

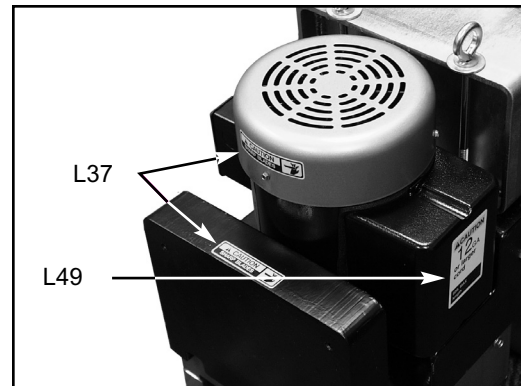
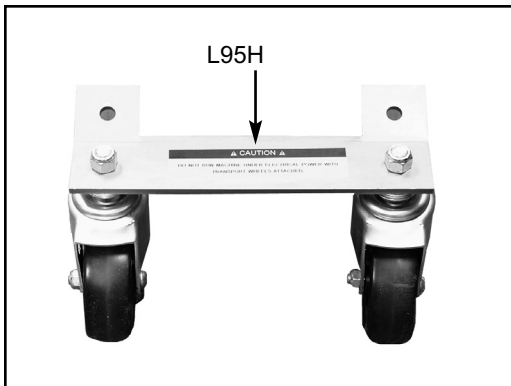
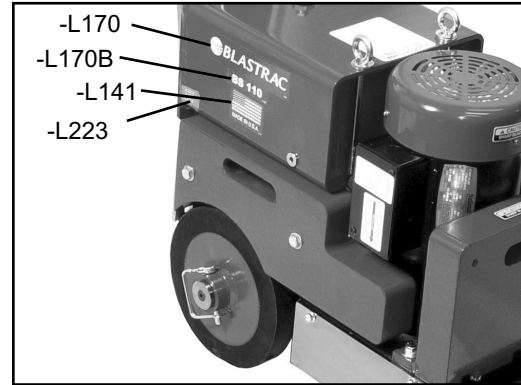
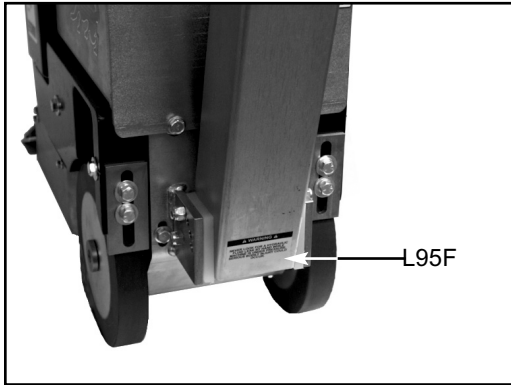

<u>PART #</u>	<u>DESCRIPTION</u>
06-L37	Caution Sharp Blade Label (2)
06-L49	Power Cord Label
06-L95F	Warning Fluid Leak Label
06-L95H	Caution Do Not Run Label
06-L95J	110 Volt Label (Not Shown)

<u>PART #</u>	<u>DESCRIPTION</u>
06-L141	Made In USA Label
06-L170	Blastrac Label (2)
06-L170B	Blastrac Stock Number Label
06-L223	Patent Number Label

BS110 LABELS

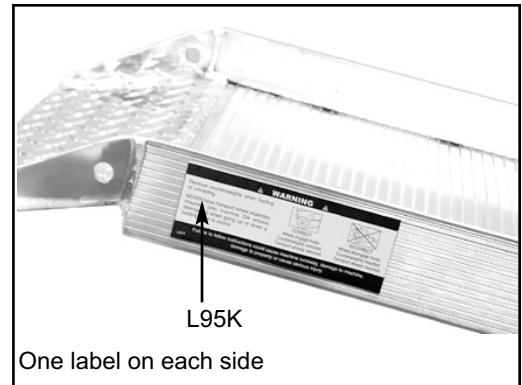
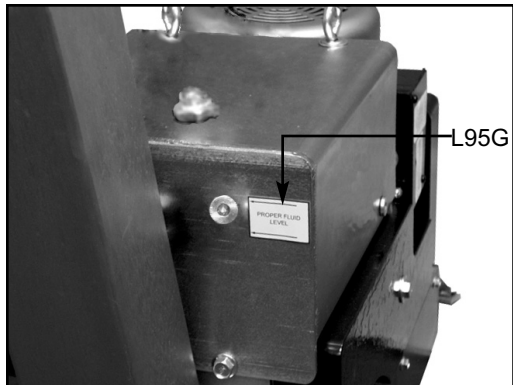
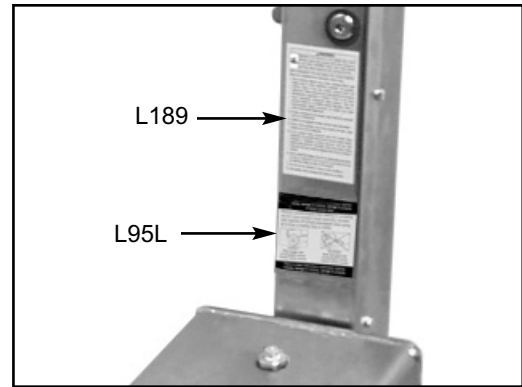
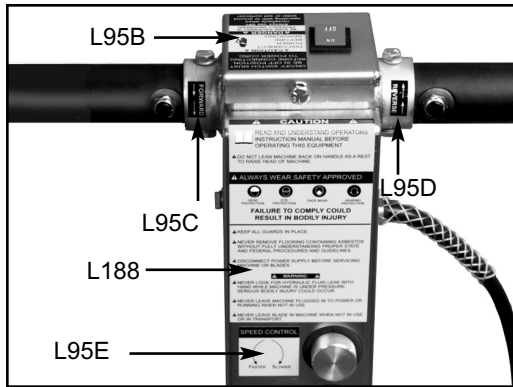

<u>PART #</u>	<u>DESCRIPTION</u>
L95B	On/Off Switch Label
L95C	Forward Label
L95D	Reverse Label
L95E	Speed Control Label
L95G	Fluid Level Label

<u>PART #</u>	<u>DESCRIPTION</u>
L95K	Ramp Label (2)
L95L	Remove Counterweights Label
L188	Caution General Info Label
L189	Safe Operating Tips Label

BS110 ACCESSORIES

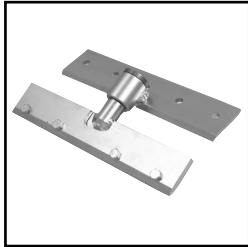

#06-6280-500 SWIVEL HEAD ATTACHMENT

Unique Swivel Head rotates to use the second sharp edge of the blade without having to remove the blade. Designed to hold razor/scrapper blades. Works on thin soft coatings, paint and hard to remove gummy or dry adhesives. This attachment is the ultimate for adhesive removal. Swivel Head allows blade to stay in contact with the floor.

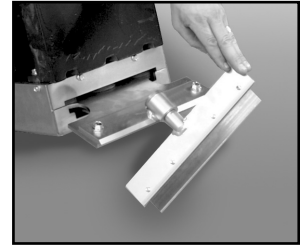

#06-6280-502 OPTIONAL SADDLE WEIGHT

Adds an extra 50 lbs. to the drive wheels.



#06-6251 LOADING RAMP

Durable light weight construction. Folds for easy transportation and storage.

06-6251-1 Replacement Pinch Point Guard (set)

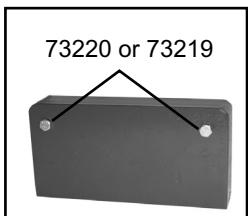
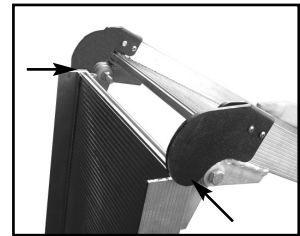

#06-6280-146A ADDITIONAL FRONT WEIGHT

Mounts onto existing front weight. Adds 20 lbs. extra weight onto the cutting head.

06-73220 3/8-16 x 3 Hexhead Bolt (For 1 Additional Weight)

06-73219 3/8-16 x 5 Hexhead Bolt (For 2 Additional Weights)



#6280-299 Front Transport Wheel Assembly

Makes movement of machine easier when transporting and helps to eliminate damage to flooring.

6280-301 Replacement Wheel Only

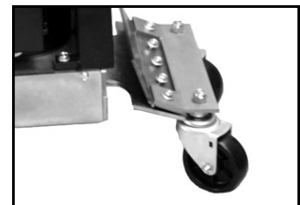

#06-6254 50' POWER CORD

12 Gauge Power Cord

06-6254-1 Female Connector Only, 4729C

06-6254-2 Male Plug Only, 5266C

120 VOLT WIRING DIAGRAM

120 VOLT, 60 HZ

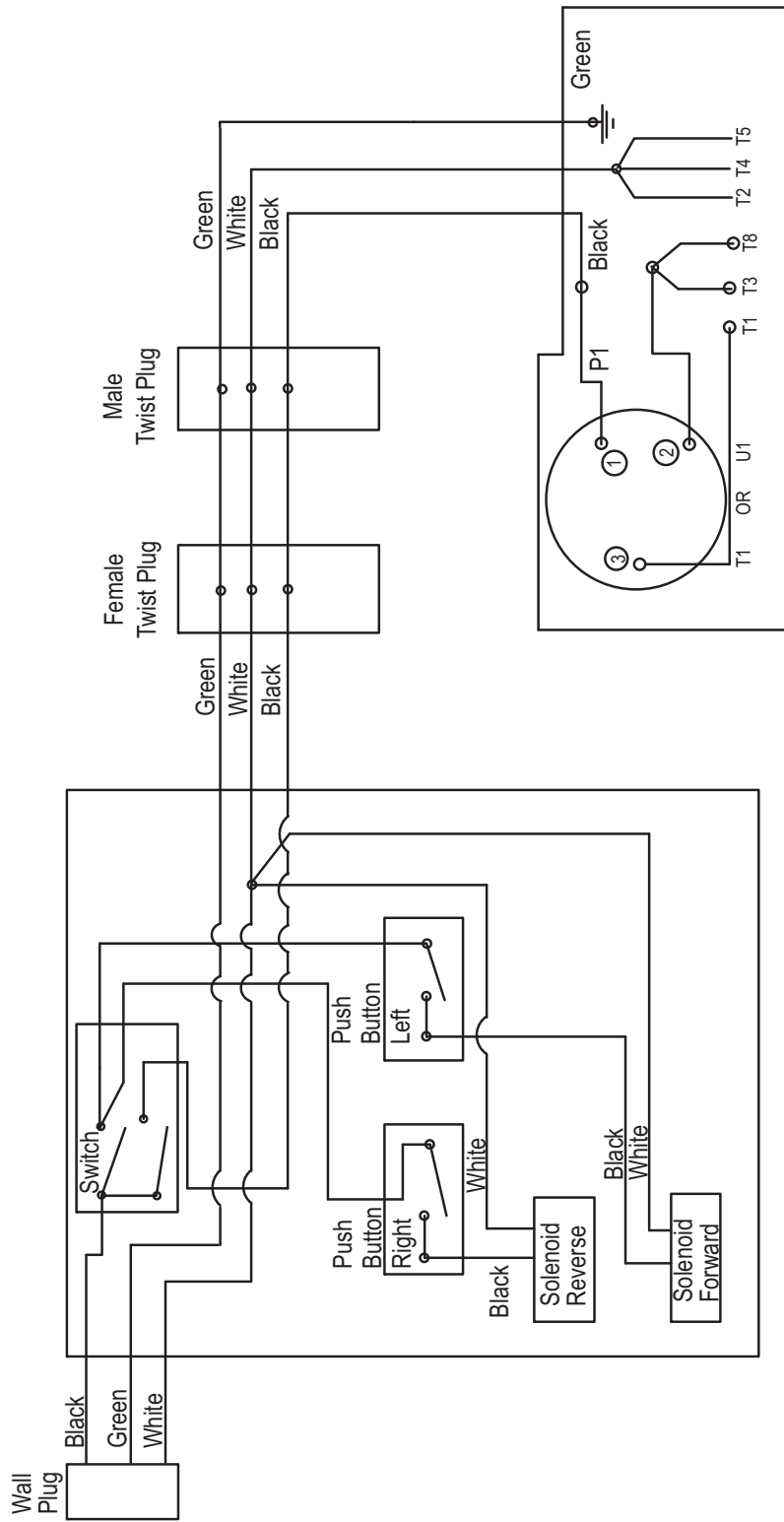

BS110 HYDRAULIC LINE LAYOUT

HYDRAULIC LINE LAYOUT

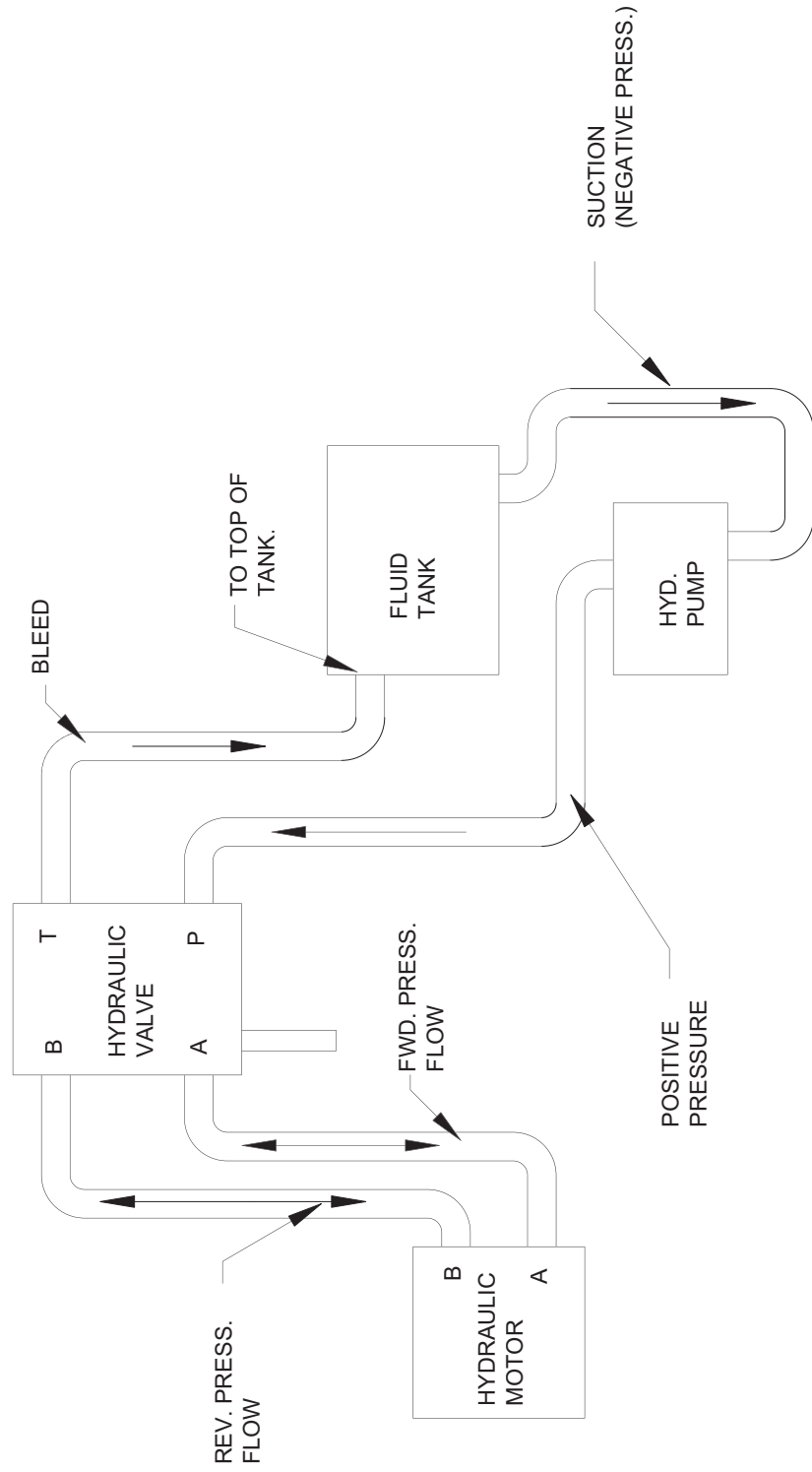

BS110 MATERIAL SAFETY DATA

Material Safety Data Sheet

SECTION 1 PRODUCT AND COMPANY IDENTIFICATION

Texaco Rando® HD 22 - 68

Product Number(s): CPS221655, CPS221657, CPS221658, CPS221659

Synonyms: Texaco Rando® HD 22, Texaco Rando® HD 32, Texaco Rando® HD 46, Texaco Rando® HD 68

Company Identification

Chevron Products Company
a division of Chevron U.S.A. Inc.
6001 Bollinger Canyon Road
San Ramon, CA 94583
United States of America
www.chevronlubricants.com

Transportation Emergency Response

CHEMTREC: (800) 424-9300 or (703) 527-3887

Health Emergency

Chevron Emergency Information Center: Located in the USA. International collect calls accepted. (800) 231-0623 or (510) 231-0623

Product Information

email : lubemsds@chevron.com
Product Information: 800-LUBE-TEK
MSDS Requests: 800-414-6737

SECTION 2 COMPOSITION/ INFORMATION ON INGREDIENTS

COMPONENTS	CAS NUMBER	AMOUNT
Highly refined mineral oil (C15 - C50)	Mixture	90 - 100 %weight

SECTION 3 HAZARDS IDENTIFICATION

IMMEDIATE HEALTH EFFECTS

Eye: Not expected to cause prolonged or significant eye irritation.

Skin: Contact with the skin is not expected to cause prolonged or significant irritation. Not expected to be harmful to internal organs if absorbed through the skin. High-Pressure Equipment Information: Accidental high-velocity injection under the skin of materials of this type may result in serious injury. Seek medical attention at once should an accident like this occur. The initial wound at the injection site may not appear to be serious at first; but, if left untreated, could result in disfigurement or amputation of the affected part.

Ingestion: Not expected to be harmful if swallowed.

Inhalation: Not expected to be harmful if inhaled. Contains a petroleum-based mineral oil. May cause respiratory irritation or other pulmonary effects following prolonged or repeated inhalation of oil mist at airborne levels above the recommended mineral oil mist exposure limit. Symptoms of respiratory irritation may include coughing and difficulty breathing.

SECTION 4 FIRST AID MEASURES

Eye: No specific first aid measures are required. As a precaution, remove contact lenses, if worn, and flush eyes with water.

BS110 MATERIAL SAFETY DATA

Skin: No specific first aid measures are required. As a precaution, remove clothing and shoes if contaminated. To remove the material from skin, use soap and water. Discard contaminated clothing and shoes or thoroughly clean before reuse.

Ingestion: No specific first aid measures are required. Do not induce vomiting. As a precaution, get medical advice.

Inhalation: No specific first aid measures are required. If exposed to excessive levels of material in the air, move the exposed person to fresh air. Get medical attention if coughing or respiratory discomfort occurs.

Note to Physicians: In an accident involving high-pressure equipment, this product may be injected under the skin. Such an accident may result in a small, sometimes bloodless, puncture wound. However, because of its driving force, material injected into a fingertip can be deposited into the palm of the hand. Within 24 hours, there is usually a great deal of swelling, discoloration, and intense throbbing pain. Immediate treatment at a surgical emergency center is recommended.

SECTION 5 FIRE FIGHTING MEASURES

Leaks/ruptures in high pressure system using materials of this type can create a fire hazard when in the vicinity of ignition sources (eg. open flame, pilot lights, sparks, or electric arcs).

FIRE CLASSIFICATION:

OSHA Classification (29 CFR 1910.1200): Not classified by OSHA as flammable or combustible.

NFPA RATINGS: Health: 0 Flammability: 1 Reactivity: 0

FLAMMABLE PROPERTIES:

Flashpoint: (Cleveland Open Cup) 150 °C (302 °F) (Min)

Autoignition: No Data Available

Flammability (Explosive) Limits (% by volume in air): Lower: Not Applicable Upper: Not Applicable

EXTINGUISHING MEDIA: Use water fog, foam, dry chemical or carbon dioxide (CO₂) to extinguish flames.

PROTECTION OF FIRE FIGHTERS:

Fire Fighting Instructions: This material will burn although it is not easily ignited. For fires involving this material, do not enter any enclosed or confined fire space without proper protective equipment, including self-contained breathing apparatus.

Combustion Products: Highly dependent on combustion conditions. A complex mixture of airborne solids, liquids, and gases including carbon monoxide, carbon dioxide, and unidentified organic compounds will be evolved when this material undergoes combustion.

SECTION 6 ACCIDENTAL RELEASE MEASURES

Protective Measures: Eliminate all sources of ignition in vicinity of spilled material.

Spill Management: Stop the source of the release if you can do it without risk. Contain release to prevent further contamination of soil, surface water or groundwater. Clean up spill as soon as possible, observing precautions in Exposure Controls/Personal Protection. Use appropriate techniques such as applying non-combustible absorbent materials or pumping. Where feasible and appropriate, remove contaminated soil. Place contaminated materials in disposable containers and dispose of in a manner consistent with applicable regulations.

Reporting: Report spills to local authorities and/or the U.S. Coast Guard's National Response Center at (800) 424-8802 as appropriate or required.

SECTION 7 HANDLING AND STORAGE

Precautionary Measures: DO NOT USE IN HIGH PRESSURE SYSTEMS in the vicinity of flames, sparks and hot surfaces. Use only in well ventilated areas. Keep container closed.

General Handling Information: Avoid contaminating soil or releasing this material into sewage and drainage systems and bodies of water.

Static Hazard: Electrostatic charge may accumulate and create a hazardous condition when handling this material. To minimize this hazard, bonding and grounding may be necessary but may not, by themselves, be sufficient. Review all operations which have the potential of generating and accumulating an electrostatic charge and/or a flammable atmosphere (including tank and container filling, splash filling, tank cleaning, sampling, gauging, switch loading, filtering, mixing, agitation, and vacuum truck operations) and use appropriate mitigating procedures. For more information, refer to OSHA Standard 29 CFR 1910.106, 'Flammable and Combustible

BS110 MATERIAL SAFETY DATA

Liquids', National Fire Protection Association (NFPA 77, 'Recommended Practice on Static Electricity', and/or the American Petroleum Institute (API) Recommended Practice 2003, 'Protection Against Ignitions Arising Out of Static, Lightning, and Stray Currents'.

Container Warnings: Container is not designed to contain pressure. Do not use pressure to empty container or it may rupture with explosive force. Empty containers retain product residue (solid, liquid, and/or vapor) and can be dangerous. Do not pressurize, cut, weld, braze, solder, drill, grind, or expose such containers to heat, flame, sparks, static electricity, or other sources of ignition. They may explode and cause injury or death. Empty containers should be completely drained, properly closed, and promptly returned to a drum reconditioner or disposed of properly.

SECTION 8 EXPOSURE CONTROLS/PERSONAL PROTECTION

GENERAL CONSIDERATIONS:

Consider the potential hazards of this material (see Section 3), applicable exposure limits, job activities, and other substances in the work place when designing engineering controls and selecting personal protective equipment. If engineering controls or work practices are not adequate to prevent exposure to harmful levels of this material, the personal protective equipment listed below is recommended. The user should read and understand all instructions and limitations supplied with the equipment since protection is usually provided for a limited time or under certain circumstances.

ENGINEERING CONTROLS:

Use in a well-ventilated area.

PERSONAL PROTECTIVE EQUIPMENT

Eye/Face Protection: No special eye protection is normally required. Where splashing is possible, wear safety glasses with side shields as a good safety practice.

Skin Protection: No special protective clothing is normally required. Where splashing is possible, select protective clothing depending on operations conducted, physical requirements and other substances in the workplace. Suggested materials for protective gloves include: 4H (PE/EVAL), Nitrile Rubber, Silver Shield, Viton.

Respiratory Protection: No respiratory protection is normally required.

If user operations generate an oil mist, determine if airborne concentrations are below the occupational exposure limit for mineral oil mist. If not, wear an approved respirator that provides adequate protection from the measured concentrations of this material. For air-purifying respirators use a particulate cartridge.

Use a positive pressure air-supplying respirator in circumstances where air-purifying respirators may not provide adequate protection.

SECTION 9 PHYSICAL AND CHEMICAL PROPERTIES

Attention: the data below are typical values and do not constitute a specification.

Color: Yellow

Physical State: Liquid

Odor: Petroleum odor

pH: Not Applicable

Vapor Pressure: <0.01 mmHg @ 37.8 °C (100 °F)

Vapor Density (Air = 1): >1

Boiling Point: >315.6°C (600°F)

Solubility: Soluble in hydrocarbons; insoluble in water

Freezing Point: Not Applicable

Melting Point: Not Applicable

Specific Gravity: 0.86 - 0.87 @ 15.6°C (60.1°F) / 15.6°C (60.1°F)

Density: 0.86 kg/l - 0.9 kg/l @ 15°C (59°F)

Viscosity: 22 cSt - 61.2 cSt @ 40°C (104°F) (Min)

SECTION 10 STABILITY AND REACTIVITY

Chemical Stability: This material is considered stable under normal ambient and anticipated storage and handling conditions of temperature and pressure.

Incompatibility With Other Materials: May react with strong acids or strong oxidizing agents, such as chlorates, nitrates, peroxides, etc.

Hazardous Decomposition Products: None known (None expected)

BS110 MATERIAL SAFETY DATA

Hazardous Polymerization: Hazardous polymerization will not occur.

SECTION 11 TOXICOLOGICAL INFORMATION

IMMEDIATE HEALTH EFFECTS

Eye Irritation: The eye irritation hazard is based on evaluation of data for similar materials or product components.

Skin Irritation: The skin irritation hazard is based on evaluation of data for similar materials or product components.

Skin Sensitization: No product toxicology data available.

Acute Dermal Toxicity: The acute dermal toxicity hazard is based on evaluation of data for similar materials or product components.

Acute Oral Toxicity: The acute oral toxicity hazard is based on evaluation of data for similar materials or product components.

Acute Inhalation Toxicity: The acute inhalation toxicity hazard is based on evaluation of data for similar materials or product components.

ADDITIONAL TOXICOLOGY INFORMATION:

This product contains petroleum base oils which may be refined by various processes including severe solvent extraction, severe hydrocracking, or severe hydrotreating. None of the oils requires a cancer warning under the OSHA Hazard Communication Standard (29 CFR 1910.1200). These oils have not been listed in the National Toxicology Program (NTP) Annual Report nor have they been classified by the International Agency for Research on Cancer (IARC) as; carcinogenic to humans (Group 1), probably carcinogenic to humans (Group 2A), or possibly carcinogenic to humans (Group 2B). These oils have not been classified by the American Conference of Governmental Industrial Hygienists (ACGIH) as: confirmed human carcinogen (A1), suspected human carcinogen (A2), or confirmed animal carcinogen with unknown relevance to humans (A3).

SECTION 12 ECOLOGICAL INFORMATION

ECOTOXICITY

This material is not expected to be harmful to aquatic organisms. The ecotoxicity hazard is based on an evaluation of data for the components or a similar material.

ENVIRONMENTAL FATE

This material is not expected to be readily biodegradable.

SECTION 13 DISPOSAL CONSIDERATIONS

Use material for its intended purpose or recycle if possible. Oil collection services are available for used oil recycling or disposal. Place contaminated materials in containers and dispose of in a manner consistent with applicable regulations. Contact your sales representative or local environmental or health authorities for approved disposal or recycling methods.

SECTION 14 TRANSPORT INFORMATION

The description shown may not apply to all shipping situations. Consult 49CFR, or appropriate Dangerous Goods Regulations, for additional description requirements (e.g., technical name) and mode-specific or quantity-specific shipping requirements.

DOT Shipping Description: PETROLEUM LUBRICATING OIL, NOT REGULATED AS A HAZARDOUS MATERIAL FOR TRANSPORTATION UNDER 49 CFR

Additional Information: NOT HAZARDOUS BY U.S. DOT. ADR/RID HAZARD CLASS NOT APPLICABLE.

IMO/IMDG Shipping Description: PETROLEUM LUBRICATING OIL; NOT REGULATED AS DANGEROUS GOODS FOR TRANSPORT UNDER THE IMDG CODE

ICAO/IATA Shipping Description: PETROLEUM LUBRICATING OIL; NOT REGULATED AS DANGEROUS GOODS FOR TRANSPORT UNDER ICAO

BS110 MATERIAL SAFETY DATA

SECTION 15 REGULATORY INFORMATION

EPCRA 311/312 CATEGORIES: 1. Immediate (Acute) Health Effects: NO
2. Delayed (Chronic) Health Effects: NO
3. Fire Hazard: NO
4. Sudden Release of Pressure Hazard: NO
5. Reactivity Hazard: NO

REGULATORY LISTS SEARCHED:

01-1=IARC Group 1	03=EPCRA 313
01-2A=IARC Group 2A	04=CA Proposition 65
01-2B=IARC Group 2B	05=MA RTK
02=NTP Carcinogen0	6=NJ RTK
	07=PA RTK

No components of this material were found on the regulatory lists above.

CHEMICAL INVENTORIES:

All components comply with the following chemical inventory requirements: AICS (Australia), DSL (Canada), ENCS (Japan), IECSC (China), KECI (Korea), PICCS (Philippines), TSCA (United States).

One or more components is listed on ELINCS (European Union). Secondary notification by the importer may be required.

NEW JERSEY RTK CLASSIFICATION:

Under the New Jersey Right-to-Know Act L. 1983 Chapter 315 N.J.S.A. 34:5A-1 et. seq., the product is to be identified as follows: PETROLEUM OIL (Hydraulic oil)

WHMIS CLASSIFICATION:

This product is not considered a controlled product according to the criteria of the Canadian Controlled Products Regulations.

SECTION 16 OTHER INFORMATION

NFPA RATINGS: Health: 0 Flammability: 1 Reactivity: 0

HMIS RATINGS: Health: 1 Flammability: 1 Reactivity: 0

(0-Least, 1-Slight, 2-Moderate, 3-High, 4-Extreme, PPE:- Personal Protection Equipment Index recommendation, *- Chronic Effect Indicator). These values are obtained using the guidelines or published evaluations prepared by the National Fire Protection Association (NFPA) or the National Paint and Coating Association (for HMIS ratings).

LABEL RECOMMENDATION:

Label Category : INDUSTRIAL OIL 1 - IND1

REVISION STATEMENT: This revision updates the following sections of this Material Safety Data Sheet: 2.

Revision Date: January 15, 2007

ABBREVIATIONS THAT MAY HAVE BEEN USED IN THIS DOCUMENT:

TLV - Threshold Limit Value	TWA - Time Weighted Average
STEL - Short-term Exposure Limit	PEL - Permissible Exposure Limit
	CAS - Chemical Abstract Service Number
ACGIH - American Conference of Government Industrial Hygienists	IMO/IMDG - International Maritime Dangerous Goods Code
API - American Petroleum Institute	MSDS - Material Safety Data Sheet

BS110 MATERIAL SAFETY DATA

CVX - Chevron	NFPA - National Fire Protection Association (USA)
DOT - Department of Transportation (USA)	NTP - National Toxicology Program (USA)
IARC - International Agency for Research on Cancer	OSHA - Occupational Safety and Health Administration

Prepared according to the OSHA Hazard Communication Standard (29 CFR 1910.1200) and the ANSI MSDS Standard (Z400.1) by the Chevron Energy Technology Company, 100 Chevron Way, Richmond, California 94802.

The above information is based on the data of which we are aware and is believed to be correct as of the date hereof. Since this information may be applied under conditions beyond our control and with which we may be unfamiliar and since data made available subsequent to the date hereof may suggest modifications of the information, we do not assume any responsibility for the results of its use. This information is furnished upon condition that the person receiving it shall make his own determination of the suitability of the material for his particular purpose.

BS110 GUARANTEE

Blastrac warrants to the first consumer/purchaser that this Blastrac® brand product (the Blastrac® BS 110 Self-Propelled Stripper), when shipped in its original container, will be free from defective workmanship and materials and agrees that it will, at its option, either repair the defect or replace the defective product or part thereof at no charge to the purchaser for parts or labor for the period(s) set forth below.

This warranty does not apply to any appearance items of the product, to the additional excluded items set forth below, or to any product, the exterior of which has been damaged or defaced, which has been subjected to misuse, abnormal service or handling, or which has been altered or modified in design or construction.

In order to enforce the rights under this limited warranty, the purchaser should follow the steps set forth below and provide proof of purchase to Blastrac.

The limited warranty described herein is in addition to whatever implied warranties may be granted to purchasers by law. ALL IMPLIED WARRANTIES INCLUDING THE WARRANTIES OF MERCHANTABILITY AND FITNESS FOR USE ARE LIMITED TO THE PERIODS FROM THE DATE OF PURCHASE AS SET FORTH BELOW. Some states do not allow time limitations on an implied warranty, so the above limitation may not apply to you.

Neither the sales person of the seller, nor any other person, is authorized to make any other warranties other than those described herein, or to extend the duration of any warranties beyond the time period described herein on behalf of Blastrac.

The warranties described herein shall be the sole and exclusive warranties granted by Blastrac and shall be the sole and exclusive remedy available to the purchaser. Correction of defects in the manner and for the period of time described herein, shall constitute complete fulfillment of all liabilities and responsibilities of Blastrac to the purchaser with respect to the product and shall constitute full satisfaction of all claims, whether based on contract, negligence, strict liability or otherwise. In no event shall Blastrac be liable, or in any way responsible for any damage or defects in the product which were caused by repairs or attempted repairs performed by anyone other than Blastrac. Nor shall Blastrac be liable, or in any way responsible, for any incidental or consequential, economics or property damage. Some states do not allow the exclusion of incidental or consequential damages, so the above exclusion may not apply to you.

THIS WARRANTY GIVES YOU SPECIFIC LEGAL RIGHTS. YOU MAY ALSO HAVE OTHER RIGHTS WHICH VARY FROM STATE TO STATE.

WARRANTY PERIOD

The Blastrac® BS 110 Self-Propelled Stripper is guaranteed to be free of manufacturer defective workmanship and in quality of materials for a period of one year.

Items excluded from warranty coverage, unless found and reported defective immediately upon removal from the original shipping container and before being used by the original purchaser.

A freight damage claim must be filed with the carrier by the purchaser, the shipper cannot file the freight claim.

To obtain service contact Blastrac toll free at 800-256-3440 for a repair authorization number. COD freight returns will not be accepted. Freight collect shipments will not be accepted. Warranty repairs must be accompanied by date of purchase receipt and a return/repair authorization number.

BS110 RETURN SHEET

Company Name _____

Contact Name _____

Telephone Number _____

Approximate Usage (hours) _____

Problems Encountered _____

Check One: Repair

Do you wish to be contacted before repairing Yes No

Return

Contact Blastrac if a loaner is needed

Return Authorization Number _____ Date _____

required, contact Blastrac

Customer Number _____

if known

Purchased From _____

if not directly from Blastrac

INTERNAL USE ONLY

Date Received _____

Unit Serial Number _____

Subject To Warranty _____

BS110 BLADE ORDER FORM

Part #	Description	Thickness	Quantity
06-130-S	3" x 10" Blade with Slots	.062	
06-130-D	3" x 10" Double Edge Blade	.062	
06-131-S	3" x 16" Blade with Slots	.062	
06-135	5" x 16" Blade	.062	
06-136	5" x 8" Blade	.062	
06-147	4" x 6" Blade	.062	
06-147-D	4" x 6" Double Edge Blade	.062	
06-148	5" x 6" Blade	.062	
06-148-D	5" x 6" Double Edge Blade	.062	
06-363-2	3/4" x 8" Scraper Blade (50/pkg)	.032	
06-368-8	7/8" x 8" Razor/Scraper Blade (50/pkg)	.045	
06-368-12	7/8" x 12" Razor/Scraper Blade (50/pkg)	.045	
06-368-15	7/8" x 15" Razor/Scraper Blade (50/pkg)	.045	
06-6255-BU	4" x 6" Self Scoring Blade	.062	
06-6257-BU	3" x 9" Self Scoring Blade	.062	
06-6258-BU	3" x 12" Self Scoring Blade	.062	
06-6259-BU	3" x 14" Self Scoring Blade	.062	
06-6277-BU	3" x 12" Self Scoring Blade	.094	
06-6278-BU	3" x 14" Self Scoring Blade	.094	
06-6270	1-1/2" x 3" Extra Heavy Duty Blade	.250	
06-6271	3" x 6" Extra Heavy Duty Blade	.250	
06-6273	3" x 11" Extra Heavy Duty Blade	.250	
06-6280-500	Swivel Head Attachment		
06-6281	3" x 8" Heavy Duty Blade	.094	
06-6282	3" x 14" Heavy Duty Blade	.094	
06-6284	3" x 12" Heavy Duty Blade	.094	
06-6285	3" x 6" Heavy Duty Blade	.094	
06-6286	3" x 10" Heavy Duty Blade	.094	
06-6290	3" x 6" Extra Heavy Duty Blade	.187	
06-6291	3" x 8" Extra Heavy Duty Blade	.187	
06-6292	3" x 12" Extra Heavy Duty Blade	.187	
06-6293	3" x 14" Extra Heavy Duty Blade	.187	
06-7050-200	3" x 6" Premium High Temp Blade	.062	
06-7050-201	3" x 8" Premium High Temp Blade	.062	
06-7050-202	3" x 10" Premium High Temp Blade	.062	
06-7050-203	3" x 12" Premium High Temp Blade	.062	
06-7050-204	3" x 14" Premium High Temp Blade	.062	
06-7080	3" x 8" Increased Angle Blade	.062	
06-7081	3" x 10" Increased Angle Blade	.062	

BILL TO: Attn: _____ Company: _____ Address: _____ _____ Phone: _____
SHIP TO: Attn: _____ Company: _____ Address: _____ _____ Phone: _____

TO ORDER:
 Phone: 800-256-3440

All orders and payment terms to be verified prior to shipping.



13201 Santa Fe • Oklahoma City, OK 73114 • U.S.A.
 Phone: 800-256-3440