

INSTRUCTION MANUAL FOR

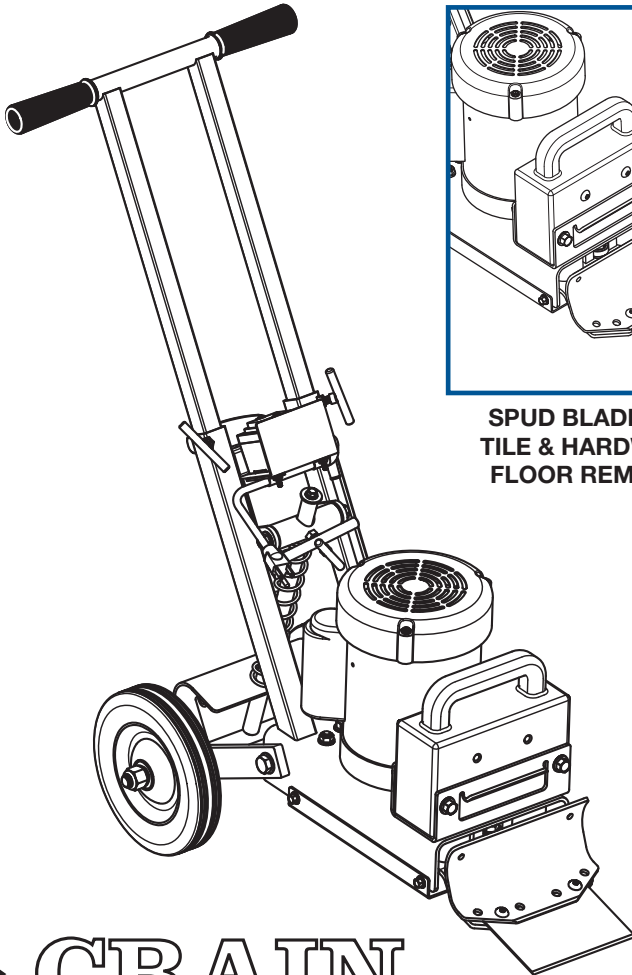

**SPUD BLADE FOR
TILE & HARDWOOD
FLOOR REMOVAL**



CRAIN

NO. 710

POWER STRIPPER

OPERATING INSTRUCTIONS: Read and save all instructions!

SAFETY FIRST: Use machine in accordance with instructions only!

- Blades are extremely sharp. Use extreme caution when loading and unloading blades from the blade carrier. The use of protective gloves is advisable during blade change. In use, keep away from the blade and oscillating blade carrier.
- Before changing blades or servicing the machine, the machine must be switched OFF and UNPLUGGED. When changing the blade, place a short wood block under the machine to hold the blade carrier off the floor surface. DO NOT lean the machine back on its extendable handle for changing blade, as this can result in unexpected tipping forward or other unexpected motion.
- Keep all body parts at a safe distance from the blade when the motor is running, including those of helpers or bystanders. Keep feet and hands out from under the machine. WARNING: after the motor is switched off, the internal mechanisms and blade may continue oscillating for a short period of time. Keep away!
- A blade should be loaded in the blade carrier during the stripping operation ONLY. Blades should be removed and safely stored during transportation and storage.
- Wear safety glasses, ear protection and gloves. This machine produces dust. Exposure to all kinds of dust can cause respiratory ailments. Check material to be removed to determine if it contains asbestos or other materials that are hazardous to be inhaled. Asbestos-containing materials should be removed by accredited abatement professionals. Use approved NIOSH or OSHA respirators, and provide adequate ventilation to eliminate or maintain dust below the threshold limit value for nuisance dust as classified by OSHA. Paper masks may not be adequate.
- Keep hands and fingers away from the motor fan cover. Internal fan can cut off fingers if contacted!
- Keep children and bystanders out of the work area. This machine is not to be used by children or persons with reduced physical, sensory or mental ability, or that lack experience and knowledge. **DON'T ALLOW RIDERS ON THE MACHINE!**
- **DANGEROUS ENVIRONMENTS:** Use and store this machine only in dry areas. Don't expose to rain or incursion of any liquids. Liquids in internal parts particularly motor, switch, and cords can create a shock hazard! Do not operate the machine when the floors in the area are wet. Don't use machine where flammable objects or explosive gases may be present, as the machine can throw sparks. Make sure the work area is well lit. Remove nails from the floor prior to using the machine. When operating over a concrete subfloor, beware of expansion joints or other obstructions that can cause the machine to stick and stop unexpectedly or kick back. Keep the machine and blade a good distance from floor mounted electrical receptacles. Inspect for and keep clear of covered or hidden wiring.
- **ACCIDENTAL STARTING:** The switch of your machine should be checked to determine that it is in proper working condition before each use. If the switch becomes damaged, repair it immediately before further use. Make sure that the machine is switched OFF before connecting it to power.
- **GROUNDING:** The cord of this machine includes a three-prong for grounding.

DO NOT remove the ground pole for use in a two-prong outlet. If necessary, use an adaptor to a two prong plug, and always ensure proper grounding. Plugging in to a GFI outlet is recommended. Make sure extension cords are grounded.

- **CORD ABUSE:** In operation, use caution not to step on the cord (or any attached extension cord). Also use caution not to cut the cord (or any attached extension cord) with the blade. Don't yank the cord to remove the plug from the electrical socket or any other reason. For best performance, we recommend that 14 gauge or heavier extension cords be used with this machine. As the length of extension cord increases, a heavier cord must be used to assure proper performance of the machine and prevent damage. Maximum extension cord length should be 50 feet. If cord, plug, or extension cords are damaged, repair or replace before further use. Unplug cord and any extension cord before transporting the machine.
- **BLADES AND ACCESSORIES:** For your safety, do not modify the machine in any way. Use only Crain replacement blades, replacement parts, and detachable weight. Use of other blades, accessories, or unauthorized modifications made to the machine can result in hazardous conditions. Make sure blades are clean and sharp. Dull blades place a heavy load on the machine that can result in overheating, unexpected sticking of the machine, or kickback. Prior to switching the machine on, remove any wrenches or other tools temporarily attached to it for blade change, repair, etc.
- **SAFE APPAREL:** Keep gloves, loose clothing and hair away from moving parts. Keep loose hair tied back. These can get caught up in moving parts. Protect feet and toes with proper work boots and good tread to prevent slipping and falling. Wear rubber gloves and rubber soled boots that provide electrical insulation.
- **MACHINE IS HEAVY:** Users with adequate strength should move the machine and the detachable weight with caution and proper lifting technique. Be careful not to drop the machine or the detachable weight onto feet or other body parts. Dropping or lowering the machine with excessive force (particularly on the blade carrier) can damage internal mechanisms. Store safely in a place that prevents machine from falling. Keep children away from machine.
- **LEAD-BASED PAINT & OTHER DUST HAZARDS:** See appendix for more info.

ASSEMBLY: (Switch off and unplug the machine during all assembly steps)

The Power Stripper comes complete with the following (see Figure 1):

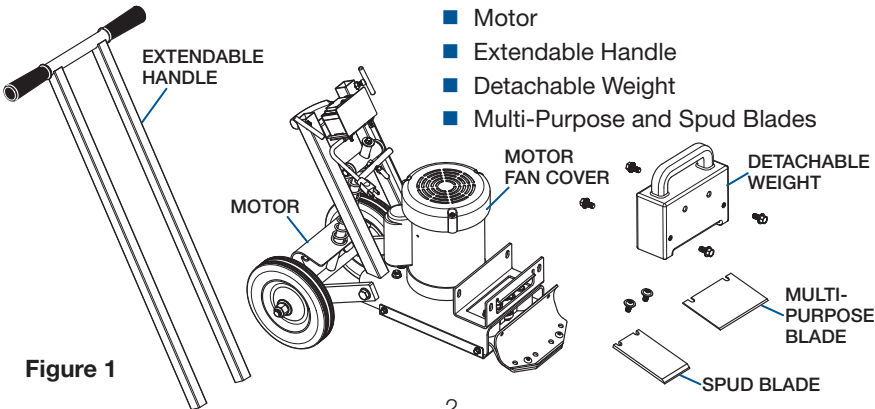
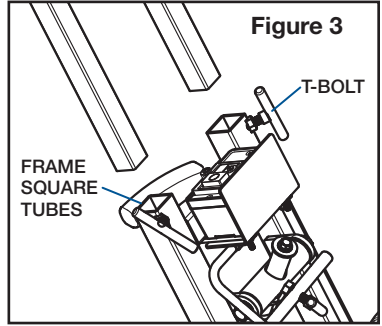
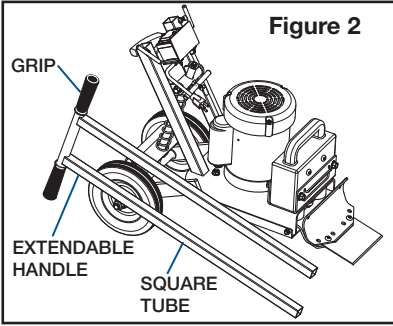

Figure 1

ASSEMBLING THE EXTENDABLE HANDLE:

- The extendable handle (Figure 2) has two square extension tubes that insert into the square tubes of the frame (Figure 3). Adjust to desired height, then tighten the T-bolts in the square tubes. For starters, adjust handle to about waist height.



INSTALLING AND CHANGING BLADES:

- Switch off and unplug the machine. For greater control, remove the detachable weight (instructions below). A T-wrench is provided for loosening blade screws (Figure 4).
- To change the blade, raise the blade carrier off the floor by placing a short piece of wood beneath the machine to provide clearance (Figure 4). DO NOT lean the machine back on its extendable handle for changing blade, as this can result in unexpected forward tipping or other unexpected motion.
- When the machine is in a stable and safe position, remove the screws currently installed in the blade carrier, and remove the blade clamp.

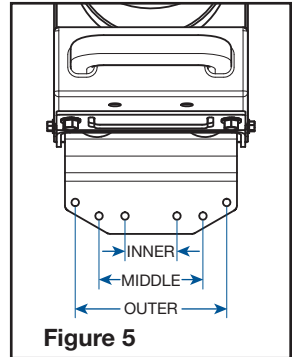
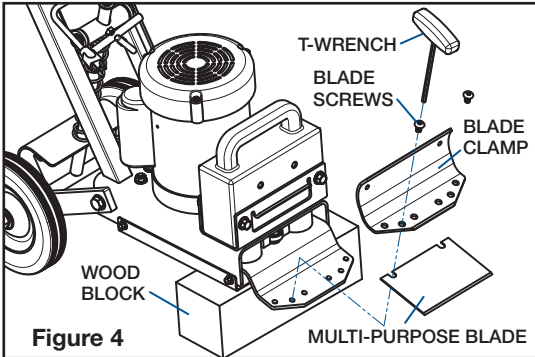

- NOTE: Crain blades with slots can be changed by loosening blade screws a few turns, pulling out previous blade, then installing the new blade. The blade screws and blade clamp do not need to be fully removed.

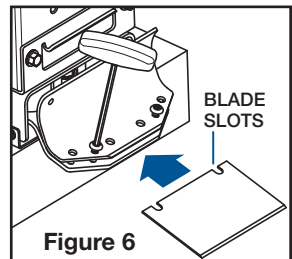

SELECTING BLADE AND BLADE CARRIER HOLES:

Select a blade for the material you are stripping. See the table below for general guidelines on blade usage. For each blade, the table also lists information about the proper screw holes to be used on the blade carrier. The screw holes are shown in Figure 5 (see previous page 3). To install the spud blade for tile or hardwood removal, use the two inner holes. For other blades, please reference the table below:

Item:	Usage / Description:	Edge:	Holes:
701	4" x 6" Vinyl	Single	Middle
702D	4" x 6" D.E. Vinyl	Double	Middle
703	5" x 6" Carpet	Single	Middle
704D	5" x 6" D.E. Carpet	Double	Middle
705	3" X 10" Multi-Purpose	Single	Middle
706D	3" x 10" D.E. Multi-Purp.	Double	Outer
707	3" x 16" Wide Cleaner	Single	Outer
708	5" x 16" Wide Cleaner	Single	Outer
711	Spud Blade Tile/Wood	Single	Inner

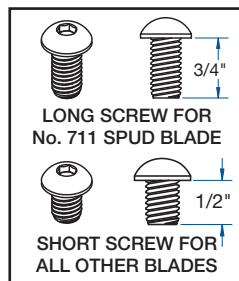

Figure 7

In general, it is advisable to begin with narrower blades to determine the difficulty of the take-up job. If the material comes up easily, switching to wider blades can take up wider sections of material. The wide 16" blades are "cleaner blades" mainly used to remove residual adhesive only after the flooring material has been stripped.

ABOUT BLADE BEVEL: See Figures 8 and 9.

When using the No. 711 Spud Blade, the blade bevel should always be up. With other blades, when stripping on concrete, install the blade with the bevel up. On wood floors, or gibcrete or soft poured flooring, install the blade with the bevel down to reduce unnecessary gouging or sticking of the blade into the floor. On soft wood subfloors (like particle board), it may be advisable to slightly dull the blades before use.



Figure 8
BEVEL UP
CONCRETE FLOORS



Figure 9
BEVEL DOWN
WOOD FLOORS

FASTENING BLADES:

- Use the longer ¾" screws with the No. 711 Spud Blade. Use the shorter ½" screws with all other blades. (See Figure 7 above.)
- The blade carrier has a number of holes for various blades (Figure 5 - see previous page 3). See the table above for the proper holes to be used with each blade.
- For Crain blades with slots, slide the blade under the blade clamp until the blade slots bottom on the blade screws. (For blades with holes, the blade screws, blade clamp, and blade must be removed, then install the screws through the blade holes.) Reassemble the blade clamp, blade and screws on the blade carrier.
- Tighten the blade clamp firmly with the proper blade screws fastened in the proper holes prior to starting the machine.
- Blade screws that are not in use can be fastened into tapped holes in the detachable weight for storage. See Figure 12 below.

DETACHABLE WEIGHT:

- The detachable weight adds 35 ½ extra pounds to the front of the machine, helping to prevent the blade from skipping over the material that is being stripped. Using the weight is advisable on any difficult tear-up job. To install the detachable weight, insert it into the weight channel at the front of the frame (Figure 10) and fasten with all four screws (two in the front and two on the back - Figure 11). **WARNING:** during transportation or storage, for greater control over the machine, remove the detachable weight. To remove weight, remove 4 screws and lift out.
- When operating over wood or other soft sub-floors, it may be advisable to remove the detachable weight to reduce gouging and sticking of the blade.

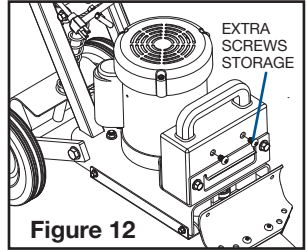
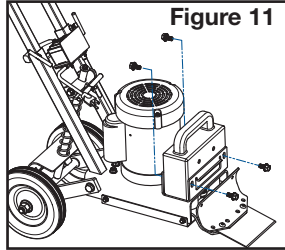
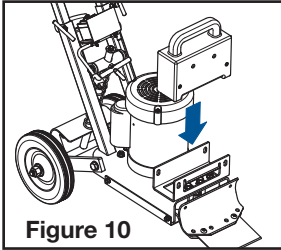

BLADE ANGLE ADJUSTMENT:

- Blade angle adjustment is achieved using the angle adjuster (Figure 13). **NOTE:** the angle adjuster is **SPRING-LOADED**. Once the inner jam nut bar and the outer T-bolt are loosened (explained below), the spring causes the machine to rise up **RAPIDLY AND FORCEFULLY**. During blade angle adjustment, keep body parts that are not needed in the adjustment process **AWAY** from the blade and the machine. Make sure that the wheels and blade carrier are on the ground.
- The angle adjuster has an outer T-bolt for setting a desired blade angle, and an inner jam nut bar for locking the T-bolt in place. To change the blade angle, first loosen the jam nut bar, then loosen the T-bolt (Figure 14). Once these fasteners are loosened, the spring causes the machine to rise up. Keep a hand on the extendable handle to control the rising motion. Press down on the handle to lower the blade angle. To raise the blade angle, allow the spring to raise the machine to the desired angle. Once the desired angle is set, tighten the outer T-bolt, then tighten the inner jam nut bar to lock the T-bolt (Figure 15).

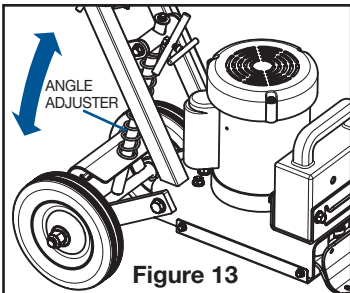

Figure 13

WARNING: HANDLE RISES FORCEFULLY WHEN JAM NUT BAR AND T-BOLT ARE LOOSENED.

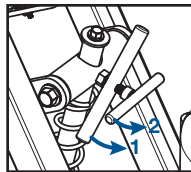

Figure 14
TO LOOSEN:

1. LOOSEN JAM NUT BAR
2. LOOSEN T-BOLT

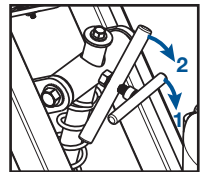

Figure 15
TO TIGHTEN:

1. TIGHTEN T-BOLT
2. TIGHTEN JAM NUT BAR

- In general, begin with a low blade angle for greatest mechanical advantage. Low angles are also advisable on wood or particle board to prevent gouging and sticking of the blade. If the blade tends to skip over the material being stripped, the blade angle can be increased to reduce the problem. Adding the detachable weight can reduce skipping. Experimenting on the job will optimize performance.

USING THE MACHINE:

- Prior to using the machine, remove nails that may be present in the floor. Pre-slitting carpet with a knife or a Crain No. 265 Stand-Up Cutter helps the machine remove the material with less effort. In the case of a wood take-up job, pre-saw the planks perpendicular to the joints into narrow rows using a circular saw. For starters, cut slits approximately 2" wide and increase width based on machine performance.
- Peel back an edge of the material to be stripped. A scraper (Crain No. 390) or a pulling claw (Crain No. 844) in the case of carpet can be helpful.
- Check that the blade is fastened properly and that the blade screws, weight screws, angle adjuster T-bolt, jam nut bar, and extendable handle T-bolts are tightened securely. Remove all wrenches or other tools attached to the machine prior to starting.
- Grip machine at the vinyl grips of the extendable handle which provide electrical insulation. Rubber gloves and rubber soled boots provide additional insulation.

- Turn on the machine by depressing the green button (Figure 16), and push the blade into the exposed edge of the flooring to be stripped. It is best to push the machine gradually and not to ram it into the material. Ramming can damage the internal mechanisms and void the warranty.

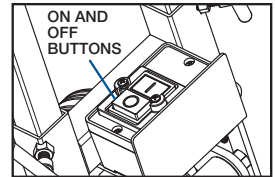

Figure 16

- Do not force the machine. The machine works best moving forward at a controlled pace.
- Keep blades sharp. Machine performance depends on sharpness of blades.
- Keep clear from the sharp blade at all times. Keep feet and hands out from under the machine.
- To stop the machine, back it away a short distance to disengage the blade from the flooring being stripped. Press the red button to turn off power to the machine (Figure 16). The machine will come to a stop shortly after it is turned off. Do not leave the machine running unattended. Switch off machine after each operation.

MAINTENANCE:

- Switch off and unplug the machine before performing any maintenance. Keep water and other liquids out of the machine particularly the motor, switch, wiring, and cords as this can cause an electrocution hazard. If the vinyl grips which provide electrical insulation are lost or damaged, replace immediately (Part No. 1375-G). Keep oil and other liquids off the vinyl grips. Do not use the machine if the switch becomes damaged or non-operational. Switch damage can cause the machine to not switch off. Do not use the machine if the cord, plug, or other wiring is cut or damaged. Do not use the machine without the protective fan cover or bottom cover in place. Keep dust and debris away from vents and openings.
- If abnormal noise or vibration occurs, switch off and unplug machine and have

REPLACEMENT PARTS DIAGRAM

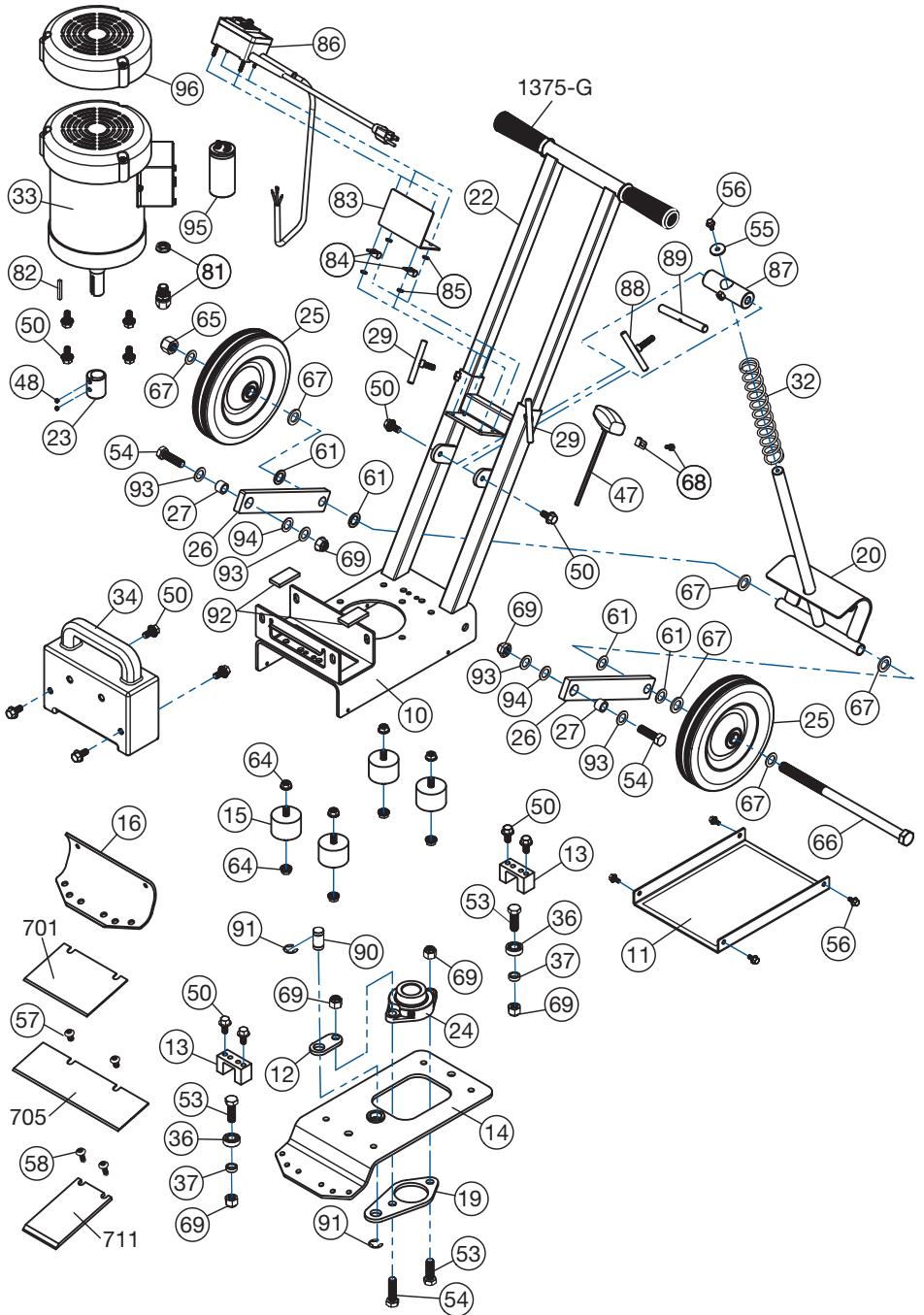

it repaired before further use. If the machine is dropped, the blade carrier (Part No. 1710-14) or blade clamp (Part No. 1710-16) can be bent or damaged. Do not use the machine until these parts have been repaired.

- Do not use the machine if it is damaged. Do not attempt to dis-assemble or re-wire the machine. Repairs should be performed by factory authorized service personnel or an electrician.
- Use new, sharp blades with your machine. Failure to do so results in poor performance or machine kick-back.

REPLACEMENT PARTS:

<i>Order No.</i>	<i>Description</i>	<i>Order No.</i>	<i>Description</i>
1710-10	Main Body	1710-56	Angle Adjuster Screw
1710-11	Cover and Foil	1710-57	Blade Clamp Screw (Short - 2)
1710-12	Bearing Block Connector	1710-58	Spud Blade Clamp Screw (Long - 2)
1710-13	Guide Channel	1710-61	Wheel Nylon Washer Set (4)
1710-14	Blade Carrier	1710-64	Rubber Damper Hex Lock Nut Set (2)
1710-15	Rubber Damper	1710-65	Wheel Axle Hex Lock Nut
1710-16	Blade Clamp	1710-66	Wheel Axle Bolt
1710-19	Pivot Plate	1710-67	Wheel Axle Washer Set (6)
1710-20	Wheel Angle Adjuster Rod	1710-68	T-Handle Wrench Holder & Screw
1710-22	Extendable Handle & Grips	1710-69	Wheel Bracket Hex Lock Nut
1710-23	Eccentric	1710-81	Motor Cable Connector
1710-24	Bearing Block	1710-82	Spindle Key
1710-25	8" Solid Rubber Wheel	1710-83	Switch Shield Plate
1710-26	Wheel Bracket	1710-84	Loop Clamp Set (2)
1710-27	Wheel Bracket Spacer	1710-85	Switchbox Nuts Set (4)
1710-29	Short T-Bolt	1710-86	Cord, Switch & Mounting Screws
1710-32	Angle Adjuster Spring	1710-87	Wheel Angle Lock Bar, Type 1
1710-33	Motor 1 HP 120V	1710-88	Long T-Bolt, Type 1
1710-34	Weight Block	1710-89	Jam Nut Bar, Type 1
1710-36	Ball Bearing	1710-90	Pivot Pin w/Grooves & E-Clips
1710-37	Bearing Spacer	1710-91	¾" E-Clips (2)
1710-47	T-Handle Wrench	1710-92	Rubber Weight Pads (2)
1710-48	Eccentric Set Screw (2)	1710-93	Steel Wheel Bracket Washer (4)
1710-50	Weight & Guide Channel Screw	1710-94	Plastic Wheel Bracket Washer (2)
1710-53	Bearing Screw	1710-95	Motor Capacitor
1710-54	Wheel Bracket Screw	1710-96	Motor Fan Top Cover w/Screws
1710-55	Wheel Angle Adjuster Washer	1375-G	Handle Grip Only

APPENDIX: IMPORTANT SAFETY INSTRUCTIONS - READ THESE INSTRUCTIONS!

WARNING: This machine produces dust and peelings. Observe the following:

WARNING: Extreme care should be taken when stripping paint. The peeling, residue and vapors of paint may contain lead, which is poisonous. Any pre-1977 paint may contain lead and paint applied to homes prior to 1950 is likely to contain lead. Once deposited on surfaces, hand to mouth contact can result in the ingestion of lead. Exposure to even low levels of lead can cause irreversible brain and nervous system damage; young and unborn children are particularly vulnerable.

Before beginning any paint removal process you should determine whether the paint you are removing contains lead. This can be done by your local health department or by a professional who uses a paint analyzer to check the lead content of the paint to be removed. **LEAD-BASED PAINT SHOULD ONLY BE REMOVED BY A PROFESSIONAL AND SHOULD NOT BE REMOVED USING A HEAT GUN.**

Persons removing paint should follow these guidelines:

1. Move the work outdoors. If this is not possible, keep the work area well ventilated. Open the windows and put an exhaust fan in one of them. Be sure the fan is moving the air from inside to outside.
2. Remove or cover any carpets, rugs, furniture, clothing, cooking utensils and air ducts.
3. Place drop cloths in the work area to catch any paint chips or peelings. Wear protective clothing such as extra work shirts, overalls and hats.
4. Work in one room at a time. Furnishings should be removed or placed in the center of the room and covered. Work areas should be sealed off from the rest of the dwelling by sealing doorways with drop cloths.
5. Children, pregnant or potentially pregnant women, and nursing mothers should not be present in the work area until the work is done and all clean-up is complete.
6. Wear a dust respirator mask or a dual filter (dust and fume) respirator mask which has been approved by the Occupational Safety and Health Administration (OSHA), the National Institute of Safety and Health (NIOSH), or the United States Bureau of Mines. These masks and replaceable filters are readily available at major hardware stores. Be sure the mask fits. Beards and facial hair may keep masks from sealing properly. Change filter often. **DISPOSABLE PAPER MASKS ARE NOT ADEQUATE.**
7. Keep food and drink out of the work area. Wash hands, arms and face and rinse mouth before eating or drinking. Do not smoke, or chew gum or tobacco in the work area.
8. Clean-up all removed paint and dust by wet-mopping the floors. Use wet cloth to clean all walls, sills, and other surface where paint or dust is clinging. **DO NOT SWEEP, DRY DUST OR VACUUM.** Use a high phosphate detergent or trisodium phosphate (STP) to wash and mop areas.
9. At the end of each work session put the paint chips and debris in a double plastic bag, close it with tape or twist ties, and dispose of properly.
10. Remove protective clothing and work shoes in the work area to avoid carrying dust in to the rest of the dwelling. Wash work clothes separately. Wipe shoes off with wet rag that is then washed with the work clothes; wash hair and body thoroughly with soap and water.

WARNING: Some dust created by power sanding, sawing, grinding, drilling, and other construction activities contains chemicals known to the State of California to cause cancer, birth defects or other reproductive harm. Some examples of these chemicals are:

- lead from lead-based paints,
- crystalline silica from brick, cement and other masonry products, and
- arsenic and chromium from chemically-treated lumber.

Your risk from these exposures varies, depending on how often you do this type of work. To reduce your exposure to these chemicals: work in a well-ventilated area, and work with approved safety equipment, such as those dust masks that are specially designed to filter out microscopic particles.

WARNING: Some flooring to be removed like carpet which originally did not contain asbestos, lead-based paint or other hazardous materials may become contaminated by deposits of asbestos fibers, peelings from lead-based paint, or other hazardous materials. Removing the carpet could result in these materials being ingested. Any contaminated product should be removed by an accredited abatement professional.

WARNING: Grinding, cutting, or drilling of masonry, concrete, metal and other materials with silica in their composition may give off dust or mists containing crystalline silica. Silica is a basic component of sand, quartz, brick clay, granite and numerous other minerals and rocks. Repeated and/or substantial inhalation of airborne crystalline silica can cause serious or fatal respiratory diseases, including silicosis.

CRAIN GUARANTEE

This No. 710 Power Stripper is guaranteed to be free of defects in workmanship or quality of materials for a period of **ONE YEAR**.

Any parts of tools found defective subject to the guarantee will be replaced at no charge. Credit in full or part cannot be extended by the distributor. New tools will not be given as replacements for those pending a warranty adjustment.

All merchandise returned subject to this warranty must be accompanied with same. All merchandise returned must be F.O.B. Milpitas, California, and must be in complete assembled units. No consideration will be given to unassembled parts. All disputes will be up to the consideration of the **CRAIN CUTTER CO., INC.** and their decision will be final.

Please fill out and mail this card to validate your **CRAIN** guarantee.

NAME _____

ADDRESS _____

CITY _____

STATE _____ ZIP _____

TOOL PURCHASED:

No. 710 Power Stripper

PURCHASED FROM: _____

DATE PURCHASED: _____

PLEASE CHECK:

INDIVIDUAL FLOORING INSTALLER

WORKROOM

FLOORING DEALER

INSTALLATION CONTRACTOR

OTHER _____

PLACE
STAMP
HERE

Crain Cutter Co., Inc.
1155 Wrigley Way
Milpitas, CA 95035-5426