

# 5700

## ALL DAY BATTERY RIDE-ON SCRAPER INSTRUCTION MANUAL



Read Manual Before Operating Machine



9250 XYLON AVE. N  
MINNEAPOLIS, MN 55445  
MAIN: 763.315.5300  
TOLL FREE: 800.245.0267  
FAX: 800.648.7124  
NATIONALEQUIPMENT.COM

### Declaration of Conformity



**National Flooring Equipment Inc.**  
9250 Xylon Ave N  
Minneapolis, MN 55445 USA

Declares that under our sole responsibility the products:

**5700, 5700-EUR, 5700-LIN, 5700-AUS, 7700,  
7700-EUR, 7700-LIN, and 7700-AUS**

Are in conformity with the provisions of the following EC  
Directive, including all amendments, and with national  
legislation implementing this directive:

**Machinery Directive 2006/42/EC**

The Following Harmonized Standards were applied:

**EN 61000-6-4 (2007) + A1 (2011) EN 61000-6-2 (2005) +  
EN/IEC 60204-1**

This Product Carries the CE Mark, which was first affixed in 2013

Place  
Minneapolis, MN

Signature

Date  
02/08/2014

**Dave Biron**  
Vice President Manufacturing  
9250 Xylon Ave N  
Minneapolis, MN 55445 USA

Place  
Jönköping, Sweden

Signature

Date  
02/08/2014

**Lars-Owe Kron**  
Appointed consultant for the EU  
Johan Skyttes väg 5  
SE-55448 Jönköping.  
Sweden

**Made in America since 1968**

# Table of Contents

<b>Table of Contents</b> .....	<b>3-4</b>
<b>Features and Specifications</b> .....	<b>5</b>
<b>Safety</b> .....	<b>6-8</b>
General Rules For Safe Operation .....	6-7
Characteristics of a Defensive Operator .....	7
Hydraulic Safety Tips .....	7
Silica Dust Warning.....	8
<b>Battery/Charger Information</b> .....	<b>9-12</b>
Charger Instructions .....	9
Machine Charging.....	10
Built In LVI.....	10
Commonly Asked Questions.....	11
Battery Troubleshooting.....	12
<b>Machine Operation</b> .....	<b>13-21</b>
Loading/Unloading.....	13
Center of Gravity.....	14
Job Site Movement .....	14
Operating Controls.....	15-16
Operational Tips.....	16
Dialing In the Machine .....	17
Applications Set-Up .....	19-20
Ditching.....	21
<b>Blades</b> .....	<b>22-25</b>
Cutting Heads .....	22
Types of Blades .....	22-24
Blade Sharpening .....	25
<b>Machine Maintenance</b> .....	<b>26-29</b>
Manual Slide Plate Removal.....	26
Raising or Lowering Manual Slide Plate .....	26
Dual Slide Plate Removal .....	26
Checking Oil Level.....	27
Oil Change Out.....	27
Hose Change Out.....	27
Wheel Motor Change Out.....	27
Foot Peg Removal.....	27
Pump Change Out.....	28
Valve Change Out.....	28
Motor Change Out .....	28
Hydraulic Cylinder Change Out .....	28
Rear Wheel Changing .....	28
Seat Replacement .....	29
<b>Troubleshooting Guide</b> .....	<b>30</b>
<b>Parts List and Diagrams</b> .....	<b>31-47</b>
Complete Parts List .....	31-32
External Parts .....	33
Cylinder Assembly .....	34
Slide Plate Assembly .....	34
Caster Wheel Assembly.....	35
Rear Wheel Assembly .....	35
Electrical Box Assembly.....	36
Battery .....	36
Back up Beeper Assembly.....	37
Handle Switch.....	37
Instruction Tube .....	37
Foot Peg Assembly.....	37
Spool and Hose Parts.....	38
Filter and Tank Parts.....	38
Hydraulic Flow Diagram.....	39
Motor.....	40

# Table of Contents

---

- Gear Pump Assembly ..... 40
- Labels ..... 41
- Weights & Wrench ..... 42
- Battery Wiring ..... 43
- Seat Wiring ..... 44
- Machine Wiring ..... 45
- Accessories ..... 46-47
- Material Safety Data Sheet (MSDS) Information ..... 48-55**
- Guarantee ..... 57**

# Features and Specifications

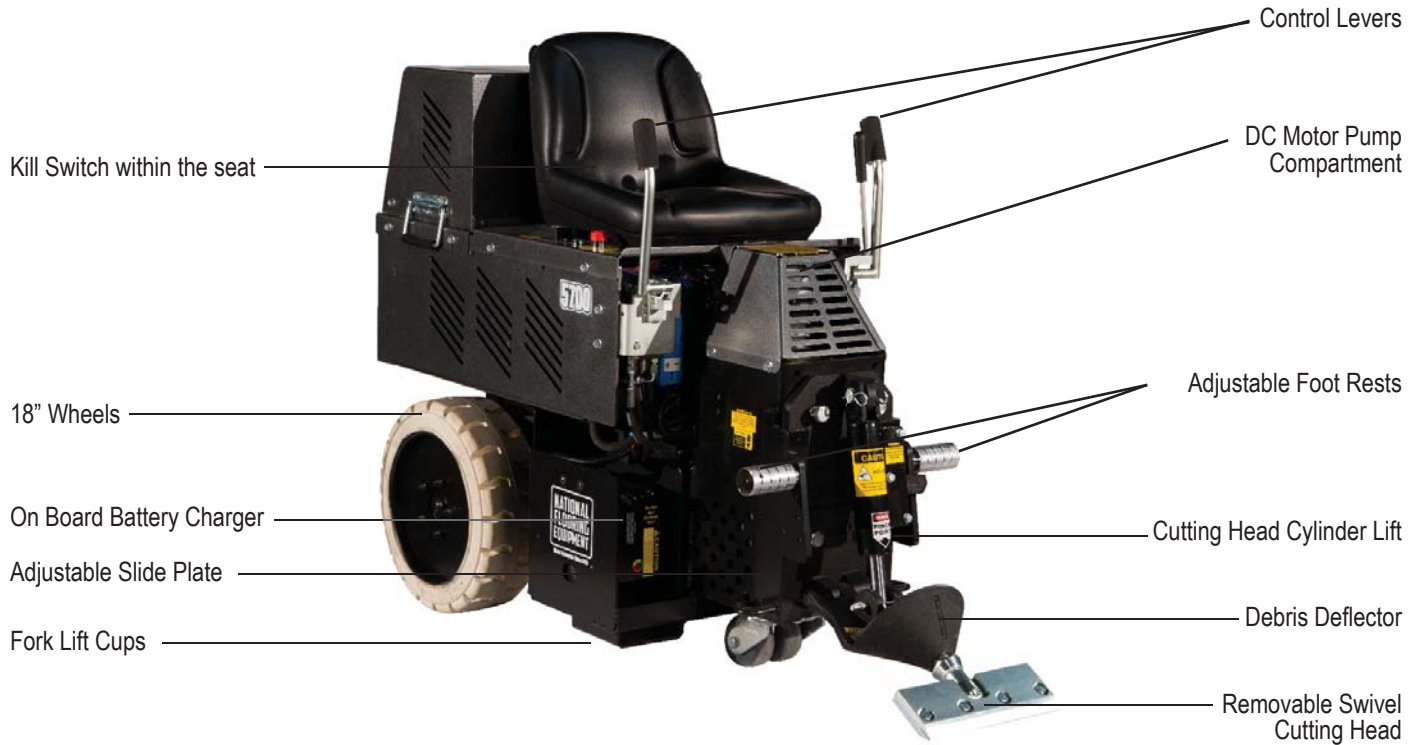

## FEATURES

**Kill Switch** - Insures the machine will not function without someone in the operator seat.

**18" Wheels** - Work on all types of application and debris build-up. They also work well for slippery/slimy residue (i.e. double stick).

**On Board Battery Charger** - Powered by 115 volts, it charges the 12 AGM batteries overnight.

**Adjustable Slide Plate** - Affords maximum versatility in blade settings.

**Fork Lift Cups** - Make it easier to load and unload on jobsites.

**Control Levers** - Forward, reverse, turn and brake with easy to move levers.

**DC Motor Pump Compartment** - Easy access for maintaining the machine.

**Adjustable Foot Rests** - For operator comfort.

**Cutting Head Cylinder Lift** - Change the angle of the cutting head with the control handle next to the operator seat.

**Debris Deflector** - Redirects debris away from the operator.

**Removable Swivel Cutting Head** - Assures continuous blade contact with the floor.

## Product Specifications

Width	Length	Height	Empty Weight	Fully Weighted	Removable Weight
24.5" (62.2 cm)	54" (137.1 cm)	47.5" (120.6 cm)	2021 lb (916.7 kg)	2196 lb (996 kg)	175 lb (79.4 kg)
Run Time	HP	Speed	Sound Level	Handle Acceleration	Handle Acceleration
8-12 hours	4	up to 120 ft./min.	94-97 dB(A)	Left .216 m/s sq.	Right .306 m/s sq.

# Safety

---

## GENERAL RULES FOR SAFE OPERATION

**READ AND SAVE ALL INSTRUCTIONS FOR FUTURE USE.** Before use, ensure operators reads and understand this manual. Read and understand labeling on machine and components. All operators must view the instruction video. Extra copies of the manual and video are available.

1. **KNOW YOUR EQUIPMENT:** Read this manual carefully to learn equipment applications and limitations, potential hazards associated with this type of equipment. Keep this manual with the equipment it is associated with.
2. **DISARM MACHINE:** Remove cutting head or drop cutting head to the floor when machine is not in use.
3. **DO NOT "SIDE HILL" MACHINE.**
4. **DISCONNECT CHARGER:** Disconnect machine from charger before operating machine.
5. **AVOID DANGEROUS ENVIRONMENTS:** Do not use in rain, damp or wet locations, or in the presence of explosive atmospheres (gaseous fumes, dust or flammable materials). Remove materials or debris that may be ignited by sparks.
6. **KEEP WORK AREA CLEAN AND WELL LIT:** Cluttered, dark work areas invite accidents.
7. **DRESS PROPERLY:** Do not wear loose clothing. These may be caught in moving parts. When working wear gloves and insulated non-skid footwear. Keep hands and gloves away from moving parts.
8. **USE SAFETY EQUIPMENT:** Proper eye protection should be worn at all times. Wear hearing protection during extended use and a dust mask for dusty operations. Hard hats, face shields, safety shoes, etc. should be worn when specified or necessary.
9. **KEEP BYSTANDERS AWAY:** Children and other bystanders should be kept at a safe distance from the work area to avoid distracting the operator and contacting the equipment or extension cord. Operator should be aware of the proximity of bystanders. This machine is not intended for use by persons (including children) with reduced physical, sensory or mental capabilities or lack of experience and knowledge.
10. **PROTECT OTHERS IN THE WORK AREA:** Provide barriers or shields as needed to protect others from debris.
11. **USE PROPER ACCESSORIES:** Using accessories that are not recommended may be hazardous. Be sure accessories are properly installed and maintained. Do not delete a guard or other safety device when installing an accessory or attachment.
12. **CHECK FOR DAMAGED PARTS:** Inspect guards and other parts before use. Check for misalignment, binding of moving parts, improper mounting, broken parts and other conditions that may affect operation. If abnormal noise or vibration occurs, turn off immediately and have the problem corrected before further use. Do not use damaged equipment. Tag damaged equipment "DO NOT USE" until repaired. Missing or damaged parts should be properly repaired or replaced immediately. For all repairs, use only identical National replacement parts.
13. **REMOVE ALL ADJUSTING KEYS AND WRENCHES:** Make a habit of checking that the adjusting keys, wrenches, etc. are removed from the tool before turning it on.
14. **GUARD AGAINST ELECTRIC SHOCK:** Prevent body contact with grounded objects such as pipes, radiators, ranges and any other related surfaces. When making cuts, always check the work area for hidden wires or pipes. Hold your equipment by insulated nonmetal grasping surfaces. Use a Ground Fault Circuit Interrupter (GFCI) to reduce shock hazards.
15. **AVOID ACCIDENTAL STARTING:** Be sure equipment is turned off before plugging in. Do not use equipment if the power switch does not turn the equipment on and off.
16. **DO NOT FORCE EQUIPMENT:** Equipment will perform best at the rate for which it was designed. Excessive force only causes operator fatigue, increased wear and reduced control.
17. **KEEP HANDS AWAY FROM ALL CUTTING EDGES AND MOVING PARTS.**
18. **WEAR** gloves when changing accessories.
19. **DO NOT ABUSE CORD:** Never unplug by pulling the cord from the outlet. Pull plug rather than cord to reduce the risk of damage. Keep the cord away from heat, oil, sharp objects, cutting edges and moving parts.
20. **DO NOT OVERREACH. MAINTAIN CONTROL:** Keep proper footing and balance at all times. Maintain a firm grip.
21. **STAY ALERT:** Watch what you are doing and use common sense. Do not use when you are tired, distracted or under the influence of drugs, alcohol or any medication causing decreased control.
22. **CHARGING MACHINE:** On/Off switch must be in off position before connecting to power source.
23. **UNPLUG EQUIPMENT:** When not in use and before changing accessories or performing recommended maintenance, unplug machine.
24. **MAINTAIN EQUIPMENT CAREFULLY:** Keep handles dry, clean and free from oil and grease. Keep cutting edges sharp and clean. Follow instructions for lubricating and changing accessories. Inspect equipment cords and extension cords for damage. Replace damaged parts. Use only identical National replacement parts.

25. **STORE IDLE EQUIPMENT:** When not in use, store in a dry, secured place. Keep away from children.
26. **MAINTAIN LABELS AND NAMEPLATES:** These carry important information. If unreadable or missing, contact National for a replacement.
27. **MACHINE IS HEAVY, DO NOT DROP.** Ensure proper lifting procedures are followed when transporting.
28. **DO NOT USE ON STEPS.**
29. **DO NOT ALLOW** the cutting heads to come into contact with the supply cord.
30. **BATTERIES:** Periodically inspect batteries, charger and all plug connections. Only the manufacturer or an authorized servicing agent should replace the batteries. Do not open or tamper with batteries. Doing so voids all warranties and could cause injury due to electrical shock.
31. **REGULARLY EXAMINE** the supply cord for damage, such as cracking or aging. If damaged, replace the cord before further use. Only replace the supply cord with the type specified in this manual.

## CHARACTERISTICS OF A DEFENSIVE OPERATOR

A Good Operator is a "Defensive" Operator!

### QUALITIES INCLUDE:

**Education:** Acquires knowledge of the machine, jobsite condition and the surrounding environment.

**Alert:** Stays alert at all times and never lets guard down.

**Skills:** Only performs duties they are qualified to do. Continually tries to improve.

**Judgment:** Use sound judgement and does not take careless chances.

**Common Sense:** Applies knowledge in practical situations.

**Recognizes the Hazards:** Maintains alertness and anticipates danger.

**Understands the Defense:** Knows that safety isn't an accident. A person must choose to follow a forward-thinking mind set.

**Acts Correctly:** Does not give in to peer pressure. Performs correctly when supervised or not.

## HYDRAULIC SAFETY TIPS

### MAINTAINING A SAFE WORK ENVIRONMENT

Establishing a safe work environment around your hydraulic equipment is paramount to safe and effective machine operation. The easiest and most effective way to avoid problems is to make sure coworkers understand equipment, know how to operate safely and recognize the danger represented if handled carelessly. A few things to be aware of:

1. **Pressure:** Hydraulic fluid under pressure is dangerous and can cause serious injury.
2. **Flammability:** When ignited, some hydraulic fluids can explode and/or cause fires.
3. **Mechanical:** Hydraulic fluid creates movement, which causes parts of your equipment to move or rotate. Always be aware of what you are doing.
4. **Moisture:** Use caution when operating in wet or high moisture conditions. Make sure all electrical fittings, switches, cords plus stain reliefs are in good condition. Always unplug when not in use and when doing any service work.
5. **Electrical:** Faulty wiring can also be an electrical hazard. A regular preventive maintenance program should always include a wiring check. Unplug batteries and/or charger before servicing.
6. **Temperature:** Because this machine operates at a relatively low pressure, overheating is not common. If surface of tank becomes too hot to touch by hand (above 130° F), shut off machine and allow to cool off.

## PRESSURE

Our system runs at or below 3,000 psi. Never look for a leak when unit is under pressure. Using your hand could cause serious injury. A few common ways to encounter hydraulic fluid under pressure include:



**WARNING:** NEVER USE YOUR HANDS TO CHECK FOR LEAKS OVER HOSE OR HYDRAULIC CONNECTIONS. USE A PIECE OF CARDBOARD TO LOCATE PRESSURIZED LEAK, FOR LOW PRESSURE LEAKS (DRIPS), USE A RAG TO CLEAN THE AREA AND DETERMINE WHERE THE LEAK ORIGINATES.

# Safety

1. **Pinhole:** Fluid under pressure can cause serious injury. It can be almost invisible escaping from a pinhole and it can pierce the skin into the body. Do not touch a pressurized hydraulic hose assembly with any part of your body. If fluid punctures the skin, even if no pain is felt, a serious emergency exists. Obtain medical assistance immediately. Failure to do so can result in loss of the injured part or death.
2. **Leak:** Keep fittings and hoses tight. Only check and service when not under pressure. Leaking hydraulic fluid is not only unsightly, it's hazardous. In addition to making workplace floors slippery and dangerous, leaks also contaminate the environment. Before cleaning an oil spill, always check EPA, state and local regulations.
3. **Burst:** Whether due to improper selection or damage, a ruptured hose can cause injury. If it bursts, a worker can be burned, cut, injected or may slip and fall.
4. **Coupling Blow-off:** If the assembly is not properly made or installed, the coupling could come off and hit or spray a worker, possibly resulting in serious injury. Never operate machine without guards.

## FLAMMABILITY

With the exception of those comprised primarily of water, all hydraulic fluid is flammable when exposed to the proper conditions (including many "fire-resistant" hydraulic fluids).

Leaking pressurized hydraulic fluids may develop a mist or fine spray that can flash or explode upon contact with a cause of ignition. These explosions can be very severe and could result in serious injury or death.

Precautions should be taken to eliminate all ignition sources from making contact with escaping fluids, sprays or mists resulting from hydraulic failures. Sources of ignition could be electrical discharges (sparks), open flames, extremely high temperatures, sparks caused by metal-to-metal contact, etc.

## HYDRAULIC FLUID

Only use Texaco Rando 46 Hydraulic Oil or Compatible Fluid like IS032. Non-compatible fluids could cause damage to unit or serious injury.

## SAFETY SWITCH

The 5700 All Day Battery Powered Ride-On has been equipped with a safety switch under the seat, which requires the operator to be seated before the 5700 can be operated. Do not attempt the start-up procedure with out being seated on the machine.

## BATTERY

- Contact with electrolytic acid can cause skin irritation and damage clothing. Wear a protective apron, gloves and goggles when working with batteries. Have plenty of fresh water and soap nearby in case battery acid contacts your skin, clothing, or eyes.
- Remove personal metal items such as bracelets, rings, necklaces, and watches when working with batteries. A battery can produce a short circuit current sufficient enough to weld metal objects, causing severe burns.
- Never smoke or allow a spark or flame in the vicinity of the batteries. Caution must be taken to reduce the risk of dropping metal tools onto the battery. A spark or short circuit may result in an explosion.

## FIRST AID

Immediately flush eyes with cold, fresh water for a minimum of 10 minutes if electrolytic acid comes in contact with eyes. Seek professional medical attention.

## VENTILATION

Blocking louvers or air flow perforations of convection or fan cooled battery chargers and/or machine will result in damage to the unit. When installing the unit leave space for air to flow freely through the intake and discharge louvers and/or perforations.



**WARNING: SILICA DUST WARNING** SCRAPING/GRINDING/CUTTING/DRILLING OF MASONRY, CONCRETE, METAL AND OTHER MATERIALS CAN GENERATE DUST, MISTS AND FUMES CONTAINING CHEMICALS KNOWN TO CAUSE SERIOUS FATAL INJURY OR ILLNESS, SUCH AS RESPIRATORY DISEASE, CANCER, BIRTH DEFECTS OR OTHER REPRODUCTIVE HARM. IF YOU ARE FAMILIAR WITH THE RISKS ASSOCIATED WITH THE PARTICULAR MATERIAL BEING CUT, REVIEW THE MATERIAL SAFETY DATA SHEET AND/OR CONSULT YOU EMPLOYER, THE MATERIAL MANUFACTURER/SUPPLIER, GOVERNMENTAL AGENCIES SUCH AS OSHA AND NIOSH AND OTHER AUTHORITIES ON HAZARDOUS MATERIALS. CALIFORNIA AND SOME OTHER AUTHORITIES, FOR INSTANCE, HAVE PUBLISHED LISTS OF SUBSTANCES KNOWN TO CAUSE CANCER, REPRODUCTIVE TOXICITY, OR OTHER HARMFUL EFFECTS. CONTROL DUST, MIST AND FUMES AT THE SOURCE WHERE POSSIBLE. IN THIS REGARD USE GOOD WORK PRACTICES AND FOLLOW THE RECOMMENDATIONS OF THE MANUFACTURER/SUPPLIER, OSHA/NIOSH, AND OCCUPATIONAL AND TRADE ASSOCIATIONS. WHEN THE HAZARDS FROM INHALATION OF DUST, MISTS AND FUMES CANNOT BE ELIMINATED, THE OPERATOR AND ANY BYSTANDERS SHOULD ALWAYS WEAR A RESPIRATOR APPROVED BY OSHA/MSHA FOR THE MATERIAL BEING CUT.





# Battery/Charger Information

## CHARGER INSTRUCTIONS

Check that the temporary label on top of the charger marked with the profile setting matches your battery type.

These chargers work very simply. Once connected and plugged into AC power, the LED will flash red for a few seconds, then turn steady red. When the cycle is 80% complete it will turn yellow, and finally green when cycle is complete.

If the profile is set to maintain the battery(s), the LED will flicker green. If the profile is set to shut off, the cycle will end with a steady green. The LED may also flicker when it is at the high limit of the charge cycle.

Look to the trouble shooting section for any deviations from this.

Before making AC connections, refer to the requirements on the charger ID label.

To reduce the risk of fire, use this charger only on branch circuits that are protected by a circuit breaker or fuse, and that are adequate to carry the power drawn by the charger.

This battery charger must be grounded to reduce the risk of electric shock. 115 volt and 230 volt chargers are equipped with a grounding type plug.

If an extension cord must be used, make sure it is in good condition. Use a three conductor cord no smaller than the size being used on the charger, and keep it as short as possible. The use of an improper extension cord could result in a risk of a fire or electric shock. Locate all cords so that they will not be stepped on, tripped over, or otherwise subjected to damage or stress.

Do not use charger if it shows signs of physical stress, or if DC output leads or connector feel hot when used.

Do not disconnect the DC output clamps, or connector from the batteries when the charger is on. The resulting arcing could cause the batteries to explode.

Failure to unplug AC power before moving or driving equipment will result in damage to cords, plugs and receptacles.

Do not over discharge batteries. Excessive discharge can cause polarity reversal of individual cells resulting in complete battery failure. Re-charge batteries as soon as possible after a deep discharge, but not if they are warm, allow a cooling down period.

**Caution:** The charger is **not** water proof they are water resistant. They cannot withstand immersion, continuous exposure (such as pressure washers or hoses) or heavy rain.

Machine contains a drive lockout option which will disable the drive mechanism of the equipment while the charger is plugged in. This will prevent damage to the AC cord or receptacle.

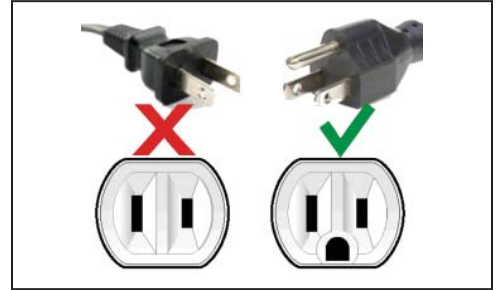

FIG. A



**WARNING:** DISCONNECT FROM POWER SOURCE BEFORE OPERATING. FAILURE TO DO SO COULD CAUSE DAMAGE TO MACHINE OR BODILY INJURY.



**WARNING:** ELECTRICAL SHOCK HAZARD. ONLY USE NATIONAL'S APPROVED CHARGING SYSTEM.

# Battery/Charger Information

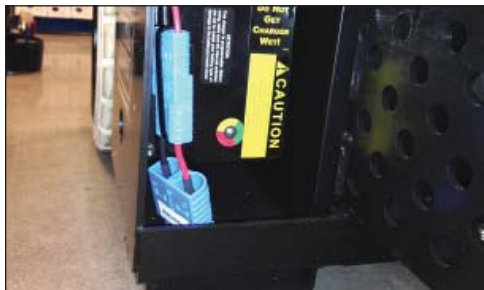

FIG. B

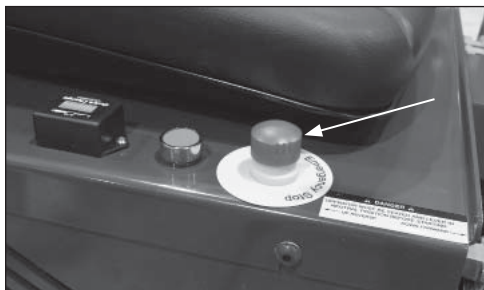

FIG. C

## MACHINE CHARGING

Machine has an on board charger (Figure B).

1. To eliminate accidental machine start-up while charging depress E-Stop Button (Figure C) before connecting to power source.
2. Connect to power source using a 7½ foot 12-gauge extension cord. NOTE: Not using the proper gauge & length extension cord could cause improper charging and/or charger damage.

Note: A steady green light indicates the machine is charging in standard charge cycle. Green light will blink when charging is complete and in maintenance mode.

3. Complete charging sequence.
4. Disconnect cord from the power source. Make sure the cord/plug is completely secured to the machine. Cord can fall under machine which causing damage to cord and/or plug.
5. Release E-Stop.

## BUILT IN LOW VOLTAGE INTERRUPT

One of the most common causes of premature battery failure is over discharging.

Low Voltage Interrupter and alarm continuously monitors for low voltage and alarms when voltage falls.

At 42V the alarm will sound, this is the point where the operator should stop and immediately move to an outlet and recharge the batteries. Further lowering of voltage will cause the alarm to speed up, decreasing the load or stopping will cause voltage to recover and slow the alarm.

At 38.4V the machine will auto-disconnect and turn off, let machine sit until batteries recover enough to drive to nearest outlet.

Warning: When alarm sounds immediately move machine to outlet for charging.



**WARNING:** ALWAYS FIND A SAFE PLACE FOR RECHARGING POWER PACKS WITH GOOD VENTILATION AWAY FROM SPARKS OR FLAME SOURCES AND AWAY FROM BYSTANDERS. ROPE OFF IF NECESSARY.

# Battery/Charger Information

---

## COMMONLY ASKED QUESTIONS

1. Question: When the charging battery has not been fully discharged will it take a memory set?

Answer: No, the design of these batteries allow charging at any stage of discharge without memory problems.

2. Question: Do I lose a complete cycle when I charge batteries that are only partially discharged?

Answer: No when 70% or higher useable charge is left. If below 70%, cycle will be used.

3. Question: Does the battery slow down as it discharges?

Answer: No, this design will give full power to 90% of the battery cycle. There will be an audible alarm alerting the operator to plug the scraper's charger into a suitable power source before a slowdown occurs.

4. Question: Can the battery spill?

Answer: No, unlike other batteries there is no liquid to spill out which allows for high shock load applications.

5. Question: Will batteries go dead during storage?

Answer: No, the battery design will hold up to 90% of its' charge up to 2 years without being used or charged.

6. Question: Does severe cold effect the batteries?

Answer: If fully charged, no. If allowed to warm up (room temperature) battery will perform better. If battery is under 75% charge, severe cold will destroy the battery.

7. Question: Do I have to let batteries cool down after charge?

Answer: No, but if you do, you will get more life out of the battery.

8. Question: Can the battery overheat and discharge gases?

Answer: Yes, if improper charger is used or the battery heats to over 50°C (125° F), gases off the vents inside of the batteries is possible. Caution must always be taken when charging batteries. Charge in a good ventilated area, away from sparks and open flame and away from bystanders.

9. Question: Can I leave the charger on too long?

Answer: No, the charging system is designed to read batteries state of charge constantly if left on for long periods of time (over the week-end) it will not hurt batteries or cause over charging problem.

10. Question: Can I leave the charger running while I am running the machine?

Answer: No, the charger must be unplugged from power supply before using.

# Battery/Charger Information

Problem	Cause	Solution
When plugged into AC power LED flashes red/green.	Connected reverse to battery, or not connected to battery.	Correct polarity, or connect to battery.
	Break in DC cord, or connector.	Have a qualified person make repair.
	Battery too dead to charge.	Replace.
When plugged into AC power LED does not come on.	No AC power.	Check circuit.
		Check extension cord for breaks or damage.
When I put a volt meter across the output of charger there is no power coming out when I plug it in.	Charger must be connected to a battery to turn on.	Connect charger to battery.
Batteries don't receive a full charge.	Charger is too small for the battery.	Check that charger's output is about 10% of the amp hour rating of the battery.
	Charge profile is not set correctly.	Recheck the dip switch setting. If in doubt, contact National.
	Cycle needs more time.	Use only a 7' (3 m) properly gauged extension cord when charging.
	Battery is defective.	Replace.
When switched on, LED flashes red/yellow.	Charger and battery voltage mismatch.	Connect charger to a battery(s) with the same voltage rating.
When powered up LED is solid red with a yellow flash.	Battery is very low, and charger is in a slow charge phase until the voltage rises to a safe level before full turn on.	Leave connected, it may take hours, but if the voltage rises even a little bit, it should recover and turn the charger full on. (Do not allow your batteries to deep discharge, it is the number one cause of premature battery failure.)
Charger blows it's fuse, or branch circuit fuse/circuit breaker as soon as it's switched on.	Charger is shorted.	Contact National or an authorized distributor's service facility.
Charger blows the branch circuit fuse/circuit breaker a short while after being switched on.	Branch circuit is too small.	Relocate charger to a branch circuit with a heavier rating, or remove other loads on the circuit.
After a full charge, the batteries die quickly.	Batteries are sulfated.	Sometimes batteries can be recovered. Leave charger on for some hours, if voltage falls and current begins to rise, it is a good sign they can recover under normal charging.
All other issues.		Please call National or an authorized distributor's service facility.

# Machine Operation

## LOADING/UNLOADING

### SAFETY PRECAUTIONS

- Always remove blade and cutting head when machine is being moved or transported.
- Cutting head and slide plate can be removed to make the machine more compact.
- NEVER leave machine unattended on an incline.
- Removing added weights help to make the machine easier and safer to move in and out of a vehicle.



**WARNING:** MACHINE HAS A SWIVEL FRONT CASTER. NEVER SIDE HILL (FIGURE A). THE MACHINE ON A INCLINE WITHOUT POWER, THE FRONT CASTER WILL CAUSE MACHINE TO SWING TO THE LOWEST POINT. IF IT IS NECESSARY TO RUN MACHINE ON AN INCLINE, RUN MACHINE ON CUTTING HEAD. PLACE AT LEAST A 8" CUTTING HEAD IN MACHINE. TO KEEP FROM DAMAGING FLOOR, CLAMP A PIECE OF CARPET INTO CUTTING HEAD TO SLIDE ON THE FLOOR. THIS WILL GIVE POSITIVE CONTACT WITH THE FLOOR WHEN POWER IS DISENGAGED FROM THE WHEELS.

### DOCK HEIGHTS

It is best to load or unload the machine from a level/equal dock height (a van from a van dock height, a truck/semi from a regular dock height).

### POWER-GATE

A power-gate can be used when the dock height is not available. Make sure gate is properly rated for 3000 lb. Make certain the machine is secure so it does not roll off the power-gate. To better secure machine, raise machine onto the lowered cutting head, raising machine off the caster. Tie machine down, chock wheels.

### RAMPS

To be safe, the ramp needs to be long to accommodate the machine being loaded/unloaded. Only use a ramp designed and rated for 3000 lb or more. Remove added weight. Do not have at a steep incline. The use of a power winch or hand come-a-long is much safer. For a van, the ramp should be 12 to 18 feet in length depending on the depth of the incline. For truck height taller than a van, longer ramps will be needed. See OSHA guidelines. It is not recommended to drive the machine, connected with power, on a ramp. Make sure ramp is secure and has good contact before using. Failure to do so could cause ramp to fall away from the vehicle.



**CAUTION:** MACHINE IS BACK HEAVY. DO NOT RUN ON STEEP INCLINE THIS COULD CAUSE MACHINE TO TIP OVER! (FIGURE E)

### FORKLIFT CUPS

There are two forklift cups mounted under the front of the machine (Figure F). Slide forklift forks through forklift cups. Slide forks all the way back to touch the rear tire (Figure G). Before lifting machine, secure machine to fork lift with heavy 3000 lb or heavier straps or chain. Tilt forks back to lift machine (Figure H).

### WINCHES

Winches should be used for safety when loading or unloading with ramps. 3000 lb. winch minimum.

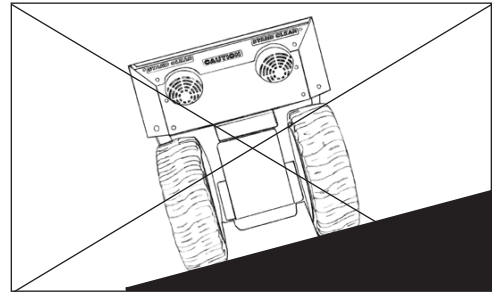

**FIG. D**  
CAUTION: DO NOT SIDE HILL

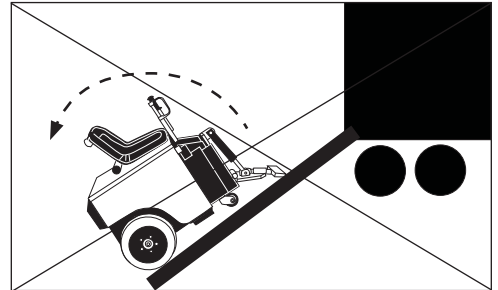

**FIG. E**  
Caution: Machine is back heavy. Do not run on steep incline. This could cause machine to tip over.

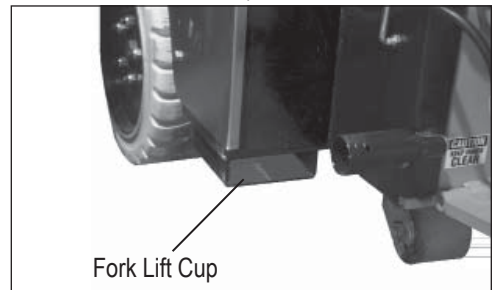

**FIG. F**

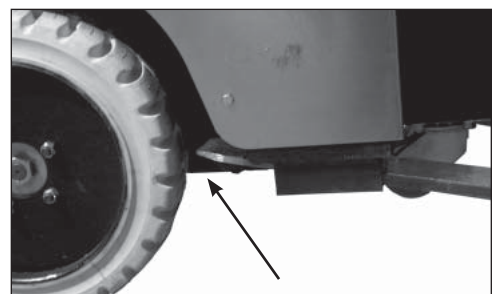

**FIG. G**

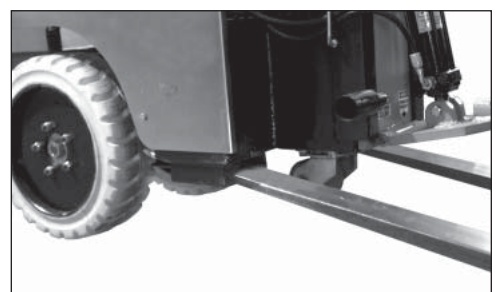

**FIG. H**

# Machine Operation

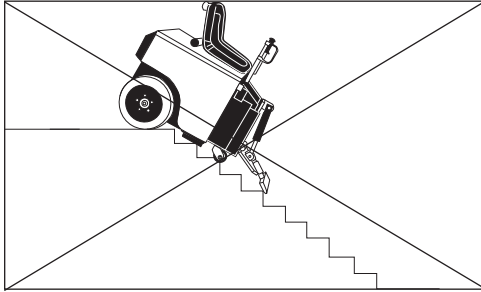

FIG. I

## TRANSPORTING

Secure machine with ratchet straps when transporting the machine. Chock wheels to keep machine from rolling, hydraulic levers should not be locked in the forward or backward position. Hydraulic levers should be straight up in the “neutral” position. This helps to lock drive wheels. Lift machine off swivel caster by lowering cutting head for better stabilization. Proper securing straps need to be rated at least twice the weight of the machine.

## WHEEL CHOCKS

Wheel chocks will help to secure the machine but DO NOT use wheel chocks alone to secure the machine.

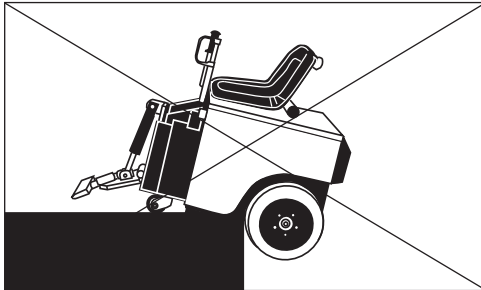

FIG. J

## PALLETIZING

Only use a solid platform pallet. If a solid platform pallet is not available, place a piece of 3/4" plywood on top of a pallet. Using a forklift with the forks inserted in the forklift cups, place machine on pallet. Use properly rated ratchet straps to secure machine to pallet.

## CENTER OF GRAVITY

Be aware of your surroundings and machines operating angles. When changing from a low slide plate to a high slide plate setting or a low cutting head angle to a high cutting head angle, the operating “attitude” of the machine changes. When a floor surface is not level (ramps, inclines, large amounts of debris which would lift the drive wheel of the machine, etc.), the center of gravity changes. Too much of an angle could make the machine unsafe (a cause for tip-over). Do Not run the machine in unsafe environments.

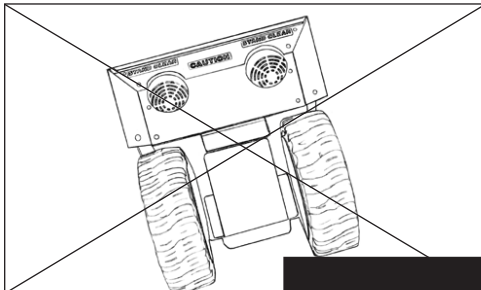

FIG. K

## JOB SITE MOVEMENT

### TAPING WHEELS

Taping the wheels with a wide like masking tape helps to prevent damage and dirt to floors during move-in and move-out.

### FRONT WHEEL ASSEMBLY (FIGURE L)

To use the Front Wheel Assembly raise slide plate so the bottom of the slide plate is higher or even with the bottom of the guide channels, 6” to 8” is ideal. Raise cylinder, insert Front Wheel Assembly into cutting head. Secure with securing pin. Caster wheel should swivel freely and the Front Wheel plate should be parallel with the floor.

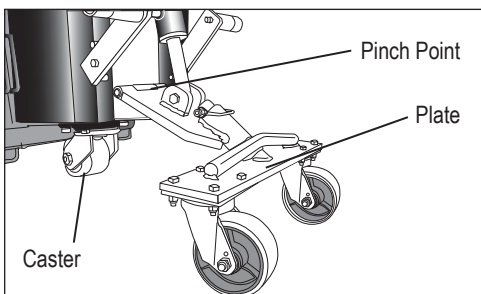

FIG. L

### TO MOVE MACHINE WITHOUT POWER (PUSHING MACHINE)

Forward: To move the machine forward, levers need to be pushed forward. To lock levers in place, connect a bungee-strap from each lever (pushing levers forward), pulling straps down to and connecting to the front plate (Figure M). Never leave machine unattended with strap holding levers open.

Backward: To move machine backward, levers need to be pulled backwards. To lock levers in place, connect a bungee-strap from each lever (pushing levers backward), Pulling straps to the back of the machine and connecting behind the seat or the rear of the machine (Figure N). Never leave machine unattended with strap holding levers open.



FIG. M

FIG. N



**CAUTION:** ALWAYS REMOVE STRAPS BEFORE STARTING MOTOR. FAILURE TO DO SO WILL MAKE MACHINE MOVE AND MAY CAUSE DAMAGE AND/OR BODILY INJURY.

# Machine Operation

## OPERATING CONTROLS

### POWER ON SWITCH (FIGURE O)

Never use the power ON switch as a method for speed control. Speed control is achieved by the hydraulic valve only. Using the on/off switch repeatedly will cause excessive wear, causing premature replacement of electrical components. An Emergency Stop Switch (E-Stop) is located by right hand (Figure P). To start machine, twist the E-Stop until it pops up. There is a seat safety switch. The operator must be properly seated for machine to operate. Push the ON button to start machine.

### MACHINE START-UP PROCEDURE

Verify 70 amp circuit breaker is in "On" position (Figure Q).

Verify 48-volt blue plugs are firmly connected (Figure R).

Operator should be properly positioned on seat.

Twist E-Stop (Figure P) to "up" position.

Push green "ON" button.

Maneuver machine with hydraulic levers (see instruction below).

### HYDRAULIC LEVERS (FIGURE S)

The hydraulic levers steer the machine. For smooth even movement, always move levers slowly. Fast movement of control levers will result in jerky, uneven movement.

Both levers forward  $\blacktriangle\blacktriangle$  move the machine forward.

Both levers backward  $\blacktriangledown\blacktriangledown$  move the machine backward.

The left lever forward and the right lever backward  $\blacktriangle\blacktriangledown$  turn the machine quickly to the right.

The left lever backward and the right lever forward  $\blacktriangledown\blacktriangle$  turn the machine quickly to the left.

Only using the left or right lever forward  $\blacktriangle$ , turns the machine slowly to the right or left.

Only using the left or right lever backwards  $\blacktriangledown$ , turns the machine slowly to the left or right.

Correcting direction while moving forward is accomplished by slightly reducing pressure on one lever or the other while moving.

The center position on levers causes wheels to lock-up.

Always chock wheels and tie down machine when transporting.

Control levers are low in vibration.

### EMERGENCY STOP SWITCH (FIGURE P)

The emergency stop switch is designed to kill the power to the system.

### SEAT SWITCH

The seat has a safety switch. Operator must be properly positioned for machine to run.

### TO STORE MACHINE (FIGURE R)

When the machine is in storage, remove the blue plug and turn circuit breaker to off. This will help to keep someone from operating the machine when it shouldn't be.

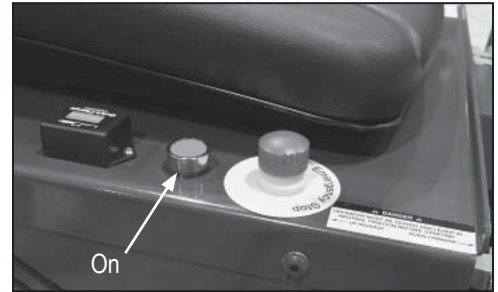

FIG. O



FIG. P



FIG. Q

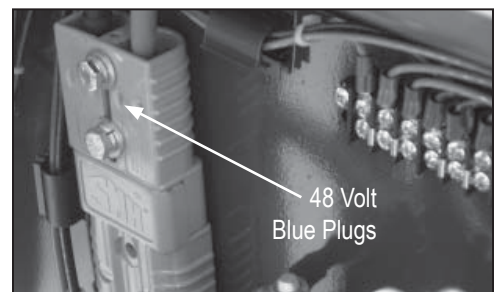

FIG. R



FIG. S

# Machine Operation

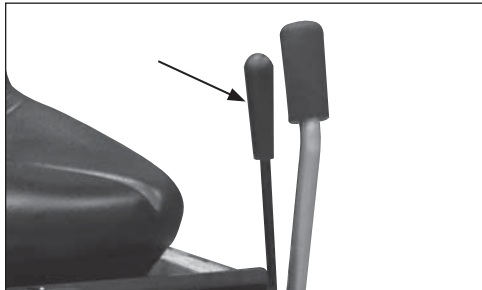

FIG. T

## CYLINDER LIFT (FIGURE T)

The cylinder lift lever raises and lowers the cylinder and cutting head. After setting slide plate to proper height, use the cylinder lift lever to set blade to proper cutting angle. Pull back ▼ on the cylinder lift lever to raise the cutting head. Push the cylinder lift lever forward ▲ to lower the cutting head. Continuing to push the cylinder lift lever forward and it will adjust the angle of the cutting head. This will also jack up the front of the machine (Figure U). This will need to be done when doing maintenance on the machine (ie: wheel changing, front caster maintenance etc). When doing machine maintenance, besides raising the cutting head angle, place blocks under the machine (Figure V). Never use the cutting head only.



FIG. U



**WARNING:** DO NOT ALTER A SWITCH OR LEVER. DO NOT DEFEAT A SAFETY DEVICE.



**WARNING:** DISARM MACHINE BY REMOVING THE CUTTING HEAD OR DROPPING THE CUTTING HEAD TO THE FLOOR WHEN THE MACHINE IS NOT IN USE.

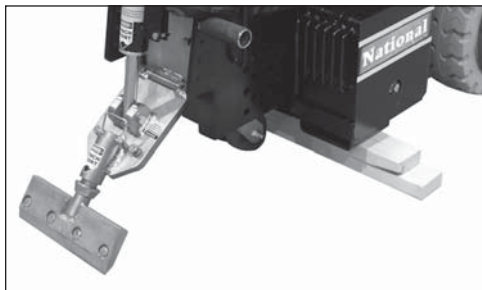

FIG. V

## OPERATIONAL TIPS

### CASTER

Keep clean and free of debris, make sure it can move freely. Clean as needed. Inspect before each use. Grease once a month.

Moving a “weighted” machine only on the front caster and not on the cutting head or the Front Wheel Assembly can seem to make the machine turn sluggish. It might turn hard to the right or the left. This is normal.

### FOOT PEG

Keep feet resting and secured on foot pegs when operating machine. Foot pegs are adjustable. Make sure securing nut is securely tightened

### SEAT

Always be properly seated before operating machine. Machine will not run if the operator is not properly seated

### DISARM MACHINE

Remove blade or drop cutting head to the floor when machine is not in use.

### LEAKAGE

Keep fittings and hoses tight. If a leak is noticeable, retighten fitting. If leakage persists, remove the connection and inspect.

### ANGLE OF THE HEAD IS SET STEEP

When raising the front of the machine to a steep angle, the bottom of the slide plate should be raised so it is higher or even with the bottom of the guide channels, 6” to 7” off the floor. This will allow for a steep blade angle without tipping the machine too far back and is usually used for re-scraping. The most common mode for take up has the slide plate approximately (1”) one inch from the floor.

### RAISING OR LOWERING THE SLIDE PLATE

This will only work with a cutting head inserted in the machine. Make sure to keep all appendages away from pinch or crush points. Completely loosen slide plate bolts. Use cylinder lift lever to raise or lower machine to move slide plate up or down.



## DIALING IN THE MACHINE

Dialing in the machine is matching the correct cutting head, blade size, blade angle and blade width to the machine to make the material removal as easy as possible. For every material being removed, there is an optimum blade width, thickness, sharpness, angle and bevel (bevel up or bevel down).

### ADJUSTING THE MANUAL SLIDE PLATE AND CUTTING HEAD (FIGURE W & X) (STANDARD WITH THE 5700)

**Caution:** Pinch point. When adjusting slide plate, keep feet and hands out from underneath the cutting head and slide plate. Failure to do so could cause severe bodily injury. When bolts are removed from the slide plate, the cutting head and the slide plate will drop down to the floor.

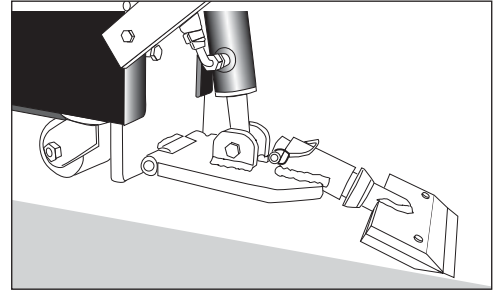

FIG. W

- Loosen the four bolts on the front of the slide plate with a 1-1/8" wrench (Figure Y).
- Slide plate up or down to achieve the desired height of the cutting head.
- A low setting orients the slide plate approximately 1" off the floor. This is for normal removal of most materials.
- A high setting orients the slide plate approximately 6" off the floor. This is for re-scraping glue and some thin-soft coatings.
- Firmly retighten all four bolts.

### ADJUSTING THE DUAL LIFT SLIDE PLATE AND CUTTING HEAD (OPTIONAL WITH THE 5700)

- For safety prior to adjusting the dual lift hydraulic slide plate make sure the channel guide is free of any debris and the machine is safely positioned on a flat surface.
- Be properly seated in the operator's seat.
- Twist the Red Emergency Stop switch located on the right side of the operator, the spring-loaded switch will pop up when twisted.
- Push the Green 'ON' button to start the machine.
- Adjacent to the left hand steering lever is a straight and narrow handle rod, this handle rod raises and lowers the front cylinder and is referred to as the 'cutting head lever'. To set the height of the hydraulic slide plate start by first adjusting the angle or pitch of the cutting head holder.
- Pull back on the cutting head lever and raise the cutting head holder to an angle higher than the bottom of the slide plate.
- Using the lever adjacent to the right hand steering lever raises and lowers the hydraulic slide plate and is referred to as the 'slide plate lever'. To lower the slide plate the operator must push forward on the slide plate lever. Reversely, to raise the slide plate the operator must pull back on the slide plate lever.

While the hydraulic slide plate can be adjusted to multiple positions there are two basic slide plate settings.

- **Low Setting:** the hydraulic slide plate is positioned 1" off the floor. This setting is most commonly used during initial scraping or removal applications; such as carpet, VCT, ceramic tile and wood flooring. (Note: The "low" setting on older model hydraulic slide plates may stop the plate within one to two inches of the floors surface.)
- **High Setting:** the hydraulic slide plate is positioned 6" off the floor or in most cases flush with the bottom of the slide plate channel guide. This setting is most often used for re-scraping glues, mastics, thin sets and soft coating.

# Machine Operation

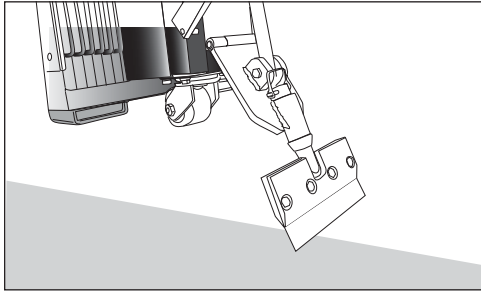

FIG. X

## SHEAR POINT

The shear point is the point where material to be removed will cut cleanly from the floor. If the blade is too wide, too dull, or too steep, the shear point is lost.

## WEIGHT VS. SHARPNESS

The most common way to compensate for a dull blade is to add more weight and raise the blade angle (see high setting). Weight allows dull blades to be used to a point. Weight also causes blades to dull and break easier. Blades of any thickness tend to catch cracks and expansion joints and will bend or break the blade if set at a high angle. For best results, run a small ditching blade at a low angle to identify as many cracks and joints as possible. If blades are breaking, you are misunderstanding the conditions.

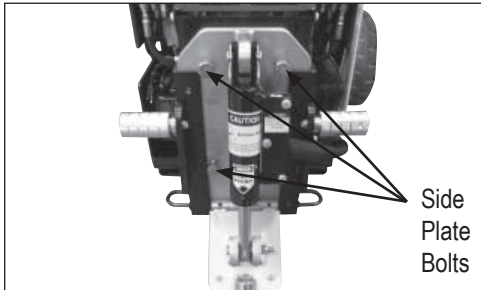

FIG. Y

## CUTTING HEAD ANGLE

Set the cutting head angle to where the material comes up the easiest. Start with a lower angle setting and raise slightly as the blade wears to maximize the shear point.

## STEEP CUTTING HEAD ANGLE

A steep angle is only used for re-scraping. The slide plate has to be raised so the bottom of the slide plate is higher or even with the bottom of the guide channels (Figure X). Raising the slide plate to an angle too steep when operating will cause the machine to jump and buck. It does not give the operator a clear vision of the cutting head and it raises the machine to operate at a unsafe operating height (Figure Z). Failure to raise the slide plate could cause machine damage and/or bodily injury.

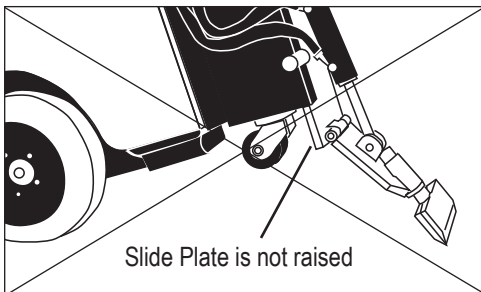

FIG. Z

## SWIVEL HEAD

The swivel head keeps the blade in contact with the floor even when the floor is uneven. When using a flat blade, turning the head over 180° allows another sharp edge on the blade without having to replace the blade.

## CUTTING HEAD INSERTION

With machine off, insert desired cutting head into cutting head holder. Secure with cutting head clip.

## SAVING TIME WITH EXTRA CUTTING HEADS

Having additional cutting heads will save time on the job. Insert blades into the extra cutting heads before starting a job. When the blade is dull, instead of taking the time to replace it or sharpen it on the job, remove the cutting head and replace it with another. In some instances a different type or size of blade is needed. Installing the other size or type of blade in a separate cutting head limits operation down time.

# Machine Operation

## SHANK BLADE INSERTION

Shank blades (Figure AA) do not require a cutting head. Insert desired shank blade into cutting head holder. Secure with cutting head clip.

## BLADE INSERTION OR BLADE CHANGING (FIGURE BB)

Using a 3/4" socket wrench, loosen bolts on cutting head. Quantity of bolts will vary depending upon cutting head size. Insert blade into the cutting head to back of notch (Figure CC). Tighten firmly. Note: A cordless 3/8" drive impact wrench will speed up this process, especially out on the job.

 **WARNING:** ALWAYS WEAR GLOVES WHEN HANDLING BLADES.

## BLADE SETTING

- Proper blade size and placement, depending on material and sub-floor type, affects performance.
- For better results during difficult removal applications use a smaller blade.
- Start with a narrow blade, then increase blade size to optimize cutting pass. Narrower blades work easier than wider blades and usually clean the floor better. Wider is not always better or faster.
- Normally bevel on blade is up for concrete (Figure CC). Bevel down for wood (Figure DD) and shoe blades (Figure EE) for soft sub-floors.
- KEEP BLADES SHARP.
- Dull blades greatly affect the performance of the machine and reduce cutting ability, sharpen or replace as needed.
- After you have removed a portion of material, clear the work area of debris. This will give the machine maximum performance and help to keep the work area safe.
- Always wear gloves when handling blades.
- Everyone in work area should wear eye protection.

## SELF-SCORING BLADES

Instead of pre-scoring a job, for soft goods (carpet, vinyl, linoleum, membrane) the self-scoring blades automatically do the scoring.

## APPLICATION SET-UP

### CERAMIC SET-UP (FIGURE FF)

The slide plate should be adjusted to a low setting (1") on inch off the floor. Use a Shank Blade or a Shank Blade with a carbide tip.

 **CAUTION:** BLADES ARE SHARP; USE EXTREME CAUTION WHEN HANDLING.

 **CAUTION:** NEVER CHANGE CUTTING HEAD OR SERVICE BLADES WHILE MACHINE IS RUNNING.

 **WARNING:** DISARM MACHINE WHEN IT IS NOT IN USE. REMOVE THE CUTTING HEAD OR DROP CUTTING HEAD TO THE FLOOR. FAILURE TO DO SO COULD CAUSE BODILY INJURY.

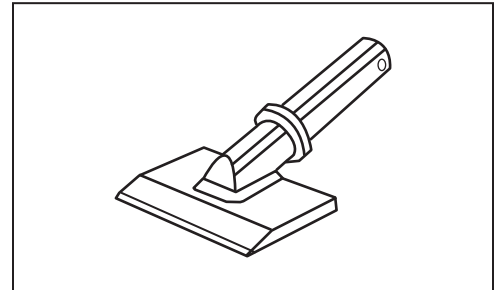

FIG. AA

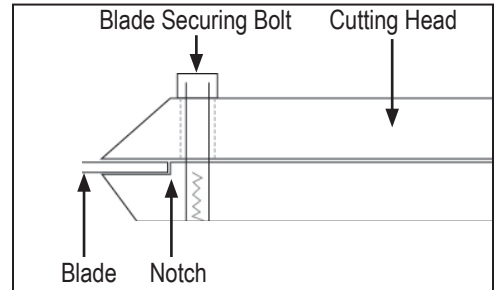

FIG. BB

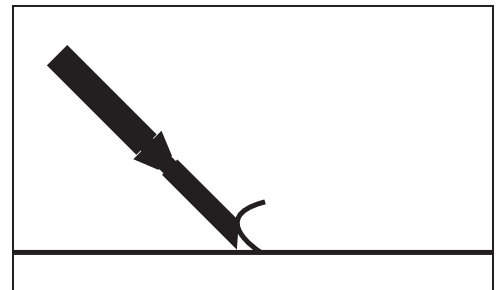

FIG. CC

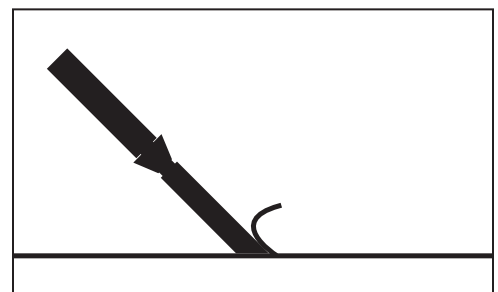

FIG. DD

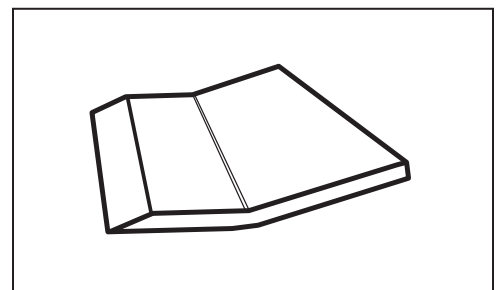

FIG. EE

# Machine Operation

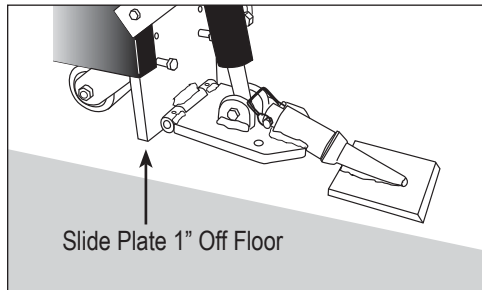

FIG. FF

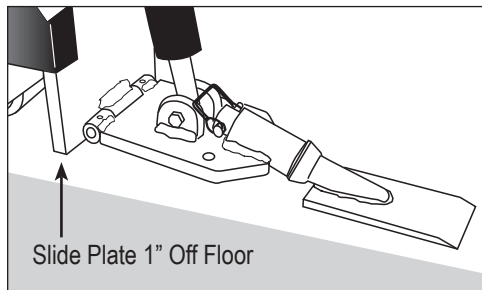

FIG. GG

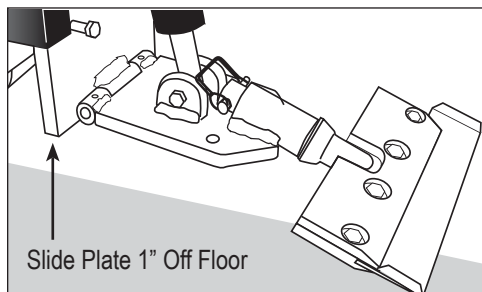

FIG. HH

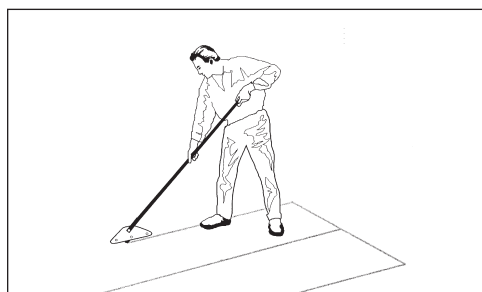

FIG. II

## WOOD SET-UP (FIGURE DD)

The slide plate should be adjusted to a low setting (1") one inch off the floor. Use Shank Blades, Shank Blades with carbide tips or a 6" or 8" Cutting Head with Shoe Blades, Bent Shoe Blades or Heavy Duty Blades. Note: Run machine 45° to the grain of the wood.

## SECONDARY BACKING CARPET SET-UP

The slide plate should be adjusted to a low setting (1") one inch off the floor. Use a Cutting head from 10" to 27" with Heavy Duty Blades or a Cutting Head from 10" to 14" with a Self-Scoring Blade.

## FOAM BACK CARPET SET-UP

The slide plate should be adjusted to a low setting (1") one inch off the floor. Use Cutting Heads from 10" to 14" with Self-Scoring Blades. If it is not stuck tight, use a Cutting Head from 14" to 27" with a Standard Blade.

## DOUBLE STICK CARPET SET-UP

The slide plate should be adjusted to a low setting (1") one inch off the floor. It is best to test to see which is the easiest way to remove double stick. Start with a Cutting Head from 10" to 14" with Self-Scoring Blades (Figure HH). If self-scoring blades do not work, score thru the carpet (Figure II) the width of the blade (Standard Blade) and scrape up. In some cases, carpet might pull off the pad and then scrape up the pad separately. Usually leaving carpet connected to the pad works the best. Sharp blades are necessary for proper operation.

Note: When removing carpet from over VCT Tile and the tile needs to be saved, run the machine at a 45° angle over the tile. This should help to save the tile.

## VCT TILE SET-UP

The slide plate should be adjusted to a low setting (1") one inch off the floor. If goods come up easily, change to a larger Cutting Head. If goods come up harder, use a Cutting Head from 6" to 8" with a Premium High Tempered Blade (.062) to match cutting head size. Sometimes a .094 blade may work better. If goods remove easily, a Tile Box #7074 can be used. A tile box also works for wind rowing, assists for a fast clean-up and collection of tile debris for quick removal.

## RUBBER TILE SET-UP

The slide plate should be adjusted to a low setting (1") one inch off the floor. Use a Cutting Head from 6" to 14" with self-scoring blades or use ditching method with a flat blade.

## RE-SCRAPING SET-UP

Slide plate should be set high, 6" to 8" off the floor. Use a Cutting Head from 8" to 27" with Scraper Blades to match cutting head size. A 15" scrapper blade would use a 14" Cutting Head. Razor Blades are faster but a Cutting Head from 8" to 14" can be used with a Standard Blade. Flip head regularly.

## THIN COATING SET-UP

Slide plate could be set high, 6" to 8" or low 1" off the floor. Test to see which works best. Use a Cutting Head from 8" to 27" with Razor Blades to match cutting head size.

## WORKING OVER CONCRETE

Blade should be bevel up when working over concrete. Pretty much anything over concrete works. Try different set-ups to see which works best. If goods come up difficult, the slide plate should be at a low setting, 1" off the floor. Use a smaller size blade. If goods come up easily, a wider blade can be used.

## WORKING OVER WOOD

A heavy machine cannot be used on wood subfloors or raised panel computer floors. Keep machine light, remove all weights. A weighted machine could break through the floor. The slide plate should be adjusted to a low setting (1") on inch off the floor. Blades should be as flat of an angle as possible. Use a "shoe blade", Extra Heavy Duty Blade (these blades have a bend to them) or a regular blade, bevel up. When using a regular blade, bending up the corners of the blade will help from the blade digging into the floor. Sometimes a shank blade or a shank blade with a carbide tip will work. Allow blade to shear material from the floor. The trick on wood floors is to run the blade flat. Approach should be at a 45° angle to the board. This keeps from digging into the board and hanging up at the seams.

## WORKING OVER SOFT SUB-FLOOR

The slide plate should be adjusted to a low setting (1") one inch off the floor. Blades should be as flat of an angle as possible. Use a "shoe blade", Extra Heavy Duty Blade (these blades have a bend to them) or a regular blade, bevel up. When using a regular blade, bending up the corners of the blade will help from the blade digging into the floor. Sometimes a shank blade or a shank blade with a carbide tip will work.



**CAUTION:** BLADES ARE SHARP; USE EXTREME CAUTION WHEN HANDLING.



**CAUTION:** NEVER CHANGE CUTTING HEAD OR SERVICE BLADES WHILE MACHINE IS RUNNING.



**WARNING:** DISARM MACHINE WHEN IT IS NOT IN USE. REMOVE THE CUTTING HEAD OR DROP CUTTING HEAD TO THE FLOOR. FAILURE TO DO SO COULD CAUSE BODILY INJURY.

# Blades

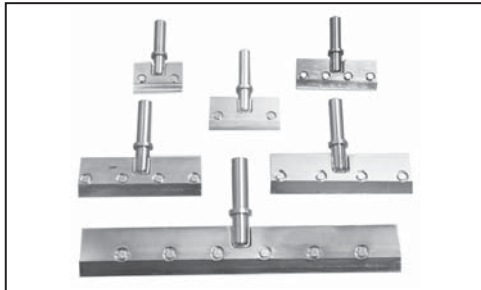

FIG. JJ

## CUTTING HEADS (FIGURE JJ)

Swivel heads rotate to use the second sharp edge of the blade without having to remove the blade. Swivel head allows blade to stay in contact with the floor.

PART#	DESCRIPTION
7050-6	6" CUTTING HEAD
7050-8	8" CUTTING HEAD
7050-10	10" CUTTING HEAD
7050-12	12" CUTTING HEAD
7050-14	14" CUTTING HEAD
7050-27	27" CUTTING HEAD



FIG. KK

## STANDARD BLADES (FIGURE KK)

This heavy duty blade is designed to remove soft goods, carpet, and vinyl flooring. Its .062 thickness offers flexibility to maximize the shear point angle.

PART#	DESCRIPTION	THICKNESS (IN.)
135	5" X 16" BLADE	.062
147	4" X 6" BLADE	.062
148	5" X 6" BLADE	.062

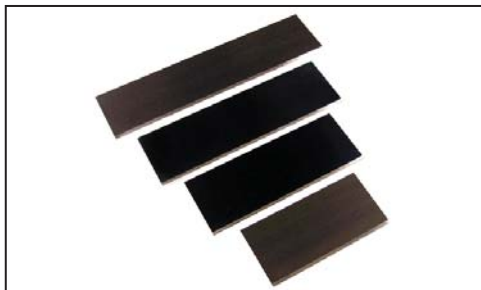

FIG. LL

## PREMIUM HIGH TEMPERED BLADES (FIGURE LL)

These ultra-high quality spring steel blades are extra hard; ensuring long blade life between sharpenings. They work on all glued down carpets, VCT, VAT, rubber tile, cork, re-scraping adhesive and elastomeric coatings. Great for floor accumulations!

PART#	DESCRIPTION	THICKNESS (IN.)
7050-200	3" X 6" PREMIUM HIGH TEMPERED BLADE	.062
7050-201	3" X 8" PREMIUM HIGH TEMPERED BLADE	.062
7050-202	3" X 10" PREMIUM HIGH TEMPERED BLADE	.062
7050-203	3" X 12" PREMIUM HIGH TEMPERED BLADE	.062
7050-204	3" X 14" PREMIUM HIGH TEMPERED BLADE	.062
7050-205	3" X 27" PREMIUM HIGH TEMPERED BLADE	.062



FIG. MM

## HEAVY DUTY BLADES (FIGURE MM)

This heavy duty blade is flexible and delivers jobsite versatility. Made with National's proven blade hardening process, these blades will stay sharper longer with better overall performance than any other blade on the market. They work on VCT, VAT, wood, tile, rubber, epoxy, elastomeric coatings, scraping thin-set and glued ceramic.

PART#	DESCRIPTION	THICKNESS (IN.)
6281	3" X 8" HEAVY DUTY BLADE	.094
6282	3" X 14" HEAVY DUTY BLADE	.094
6283	3" X 27" HEAVY DUTY BLADE	.094
6284	3" X 12" HEAVY DUTY BLADE	.094
6285	3" X 6" HEAVY DUTY BLADE	.094
6286	3" X 10" HEAVY DUTY BLADE	.094
6240	4" X 6" HEAVY DUTY BLADE	.094
6241	4" X 8" HEAVY DUTY BLADE	.094
6242	4" X 12" HEAVY DUTY BLADE	.094
6243	4" X 15" HEAVY DUTY BLADE	.094
6244	4" X 24" HEAVY DUTY BLADE	.094
6245	4" X 10" HEAVY DUTY BLADE	.094
6246	4" X 27" HEAVY DUTY BLADE	.094

## EXTRA HEAVY DUTY BLADES (FIGURE NN)

Extremely hard, high abrasion alloy for tough tear up situations. VCT, VAT, wood, tile, lighter ceramic, rescraping thin-set, all carpets, cork, elastomeric coatings, rescraping rubber and urethane coatings. Holds the edge extremely well.

PART#	DESCRIPTION	THICKNESS (IN.)
6290	3" X 6" EXTRA HEAVY DUTY BLADE	.187
6291	3" X 8" EXTRA HEAVY DUTY BLADE	.187
6292	3" X 12" EXTRA HEAVY DUTY BLADE	.187
6293	3" X 14" EXTRA HEAVY DUTY BLADE	.187
6294	3" X 27" EXTRA HEAVY DUTY BLADE	.187

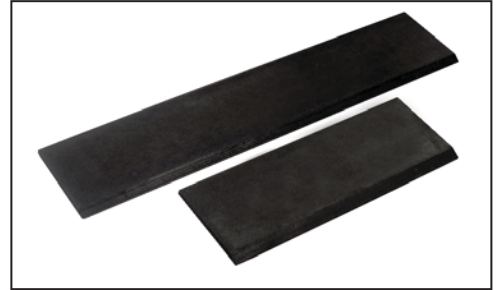

FIG. NN

## STRAIGHT SHANK BLADES (FIGURE OO)

Works well for ceramic, wood and thick epoxy. The ultimate for the toughest removals. Made from an ultra-tough alloy, which is put through special processing to give these blades unbelievable edge holding ability for ceramic epoxy, thin-set, mud set, decorative concrete toppings and much more.

PART#	DESCRIPTION	THICKNESS (IN.)
7070-2	4" X 2" STRAIGHT SHANK BLADES	.500
7070-3	4" X 3" STRAIGHT SHANK BLADES	.500
7070-4	4" X 4" STRAIGHT SHANK BLADES	.500
7070-6	4" X 6" STRAIGHT SHANK BLADES	.500



FIG. OO

## ANGLE SHANK BLADES (FIGURE PP)

Works well for ceramic and thick epoxy. The same application as the #7070 blades, but is mounted at an angle to achieve the optimum shear point for optimum performance.

PART#	DESCRIPTION	THICKNESS (IN.)
7071-2	4" X 2" ANGLE SHANK BLADES	.500
7071-3	4" X 3" ANGLE SHANK BLADES	.500
7071-4	4" X 4" ANGLE SHANK BLADES	.500
7071-6	4" X 6" ANGLE SHANK BLADES	.500



FIG. PP

## STRAIGHT SHANK BLADES WITH CARBIDE TIP (FIGURE QQ)

Works well for ceramic and thick epoxy. The same application as the #7070 blades, but are carbide tipped for holding a sharp edge for long periods. Nothing else performs like carbide when no other blade will work. Works well on elastomeric coatings.

PART#	DESCRIPTION	THICKNESS (IN.)
7072-2	4" X 2" STRAIGHT SHANK W/CARBIDE TIP	.500
7072-3	4" X 3" STRAIGHT SHANK W/CARBIDE TIP	.500
7072-4	4" X 4" STRAIGHT SHANK W/CARBIDE TIP	.500
7072-6	4" X 6" STRAIGHT SHANK W/CARBIDE TIP	.500



FIG. QQ

## ULTRA HEAVY DUTY CERAMIC EPOXY ANGLE SHANK BLADES WITH CARBIDE TIPS (FIGURE RR)

Designed for ceramic removal and thin-set rescraping. 1/2" of carbide. The extra carbide allows for maximum resharp- ening. Strong enough to work on machines up to 3500 lbs.

PART#	DESCRIPTION	THICKNESS (IN.)
7079-2	2" X 6" ULTRA HD CERAMIC EPOXY BLADE	.500
7079-4	4" X 6" ULTRA HD CERAMIC EPOXY BLADE	.500
7079-6	6" X 6" ULTRA HD CERAMIC EPOXY BLADE	.500



FIG. RR

# Blades

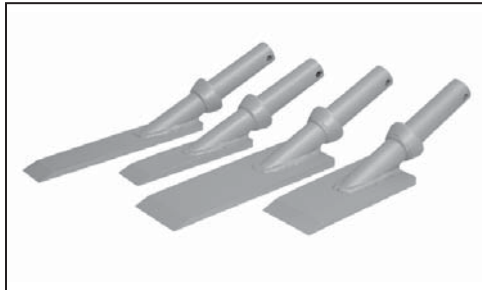

FIG. SS

## TAPERED CUTTING HEAD SHANK BLADES (FIGURE SS)

The longer taper works great on tough wood floors (glued & nailed). The long length allows the blade to easily slide under tough material. Works well on most ceramics and VCT.

PART#	DESCRIPTION	THICKNESS (IN.)
7075-8	2" X 8" TAPERED CUTTING HEAD SHANK	.300
7075-11	2" X 11" TAPERED CUTTING HEAD SHANK	.300
7077-8	3.5" X 8" TAPERED CUTTING HEAD SHANK	.300
7077-11	3.5" X 11" TAPERED CUTTING HEAD SHANK	.300



FIG. TT

## SELF-SCORING BLADES (FIGURE TT)

Tough, long lasting, self-scoring blades. 90° angled self-scoring wings. Made from National's proven blade hardening process, performs up to ten times longer than the competition. Works on attached cushion, Unitary or secondary backing, vinyl back, soft to medium PVC, linoleum, carpet tiles, soft cork, Enhancer and Unibond hot melts.

PART#	DESCRIPTION	THICKNESS (IN.)
6257-BU	3" X 9" SELF-SCORING BLADE	.062
6258-BU	3" X 12" SELF-SCORING BLADE	.062
6259-BU	3" X 14" SELF-SCORING BLADE	.062
6260-BD	3" X 6" HEAVY DUTY DITCHING	.094
6276-BU	3" X 10" SELF-SCORING BLADE	.094
6277-BU	3" X 12" SELF-SCORING BLADE	.094
6278-BU	3" X 14" SELF-SCORING BLADE	.094
6279-BU	3" X 27" SELF-SCORING BLADE	.094
6247	4" X 10" SELF-SCORING BLADE	.094
6249	4" X 12" SELF-SCORING BLADE	.094
6248	4" X 24" SELF-SCORING BLADE	.094
6256-BU	4" X 6" W/ 4" BU SELF-SCORING BLADE	.062
6261-BU	3" X 12" W/ 4" BU SELF-SCORING BLADE	.062



FIG. UU

## INCREASED ANGLE BLADES (FIGURE UU)

Mainly used for VCT, but can be used on most other applications. Supplies more of an angle when angle is needed. Prevents machine from jumping off material.

PART#	DESCRIPTION	THICKNESS (IN.)
7081	3" X 10" INCREASED ANGLE BLADE	.062
7083	3" X 8" INCREASED ANGLE BLADE	.062

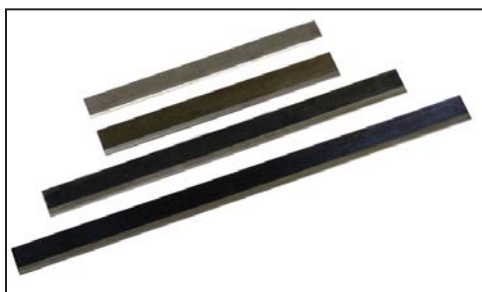

FIG. VV

## TAPERED CUTTING HEAD SHANK BLADES (FIGURE VV)

Razor sharp, super hard for scraping thin epoxies, thin mil coatings like urethane paint, poured elastomeric coatings up to 60 mil, hard to remove adhesives and much more.

PART#	DESCRIPTION	THICKNESS (IN.)
363-2	3/4" X 8" RAZOR/SCRAPER BLADE (50/PKG)	.032
368-8	7/8" X 8" RAZOR/SCRAPER BLADE (50/PKG)	.045
368-12	7/8" X 12" RAZOR/SCRAPER BLADE (50/PKG)	.045
368-15	7/8" X 15" RAZOR/SCRAPER BLADE (50/PKG)	.045

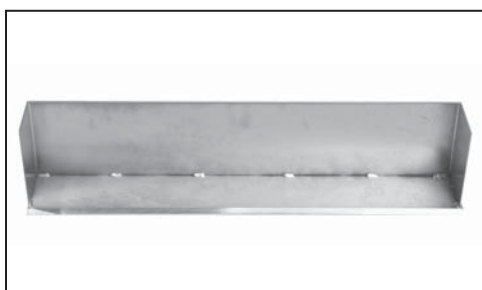

FIG. WW

## TILE BOX (FIGURE WW)

Assists for a fast cleanup and collection of tile debris for quick removal. Can be used to remove easy to remove tile. Extremely high abrasion alloy for a long lasting edge. Edge can be re-sharpened.

PART#	DESCRIPTION	THICKNESS (IN.)
7074	5" X 27" TILE BOX WITH 6" HIGH BOX	.187



## 1" BLADES (FIGURE XX)

Short profile blades where a rigid blade application is needed. Thickness greatly reduces breakage. Used for VCT & adhesive rescrapes. Works well for parking deck coatings, epoxies & elastomeric coatings.

PART#	DESCRIPTION	THICKNESS (IN.)
7091	1" X 4" BLADE	.094
7092	1" X 8" BLADE	.094
7093	1" X 10" BLADE	.094
7094	1" X 12" BLADE	.094

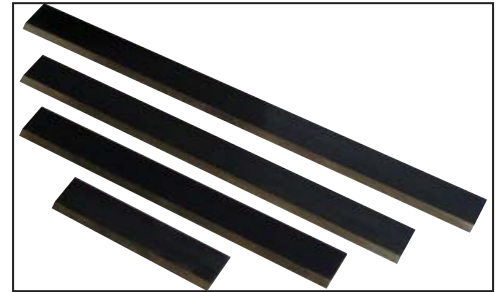

FIG. XX

## BLADE SHARPENING (FIGURE YY)

Always check for blade sharpness before using; because dull blades greatly reduce cutting effectiveness. Over time, the used blades will develop a back bevel. While re-sharpening, blades will not recover entirely until the back bevel is completely leveled out.

NOTE: Thinner blades are easier to sharpen, but they also break easier.

- Always wear gloves and safety glasses.
- Grind blade using a 4" diameter disk with 120 or finer grit. Be careful not to catch disk on edge or corner of blade.
- Pass grinder along blade edge starting on one end and continuing in one direction being careful to hold grinder at proper angle of blade. Grind until sharp.
- While using a high quality fine tooth hand file, follow the same procedure as above.
- Blades are sharp. Use extreme caution.
- Have plenty of sharp blades on each job so on-the-job blade sharpening is eliminated.
- It is best to re-sharpen dull blades on proper bench or belt grinder in the shop, so the blades are ready for the next job.

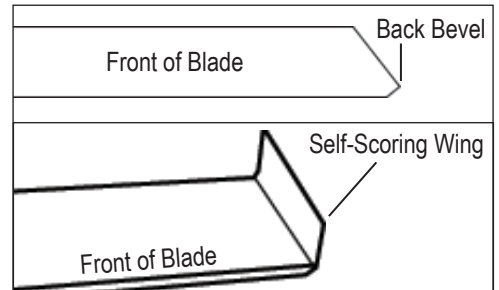

FIG. YY

## SELF-SCORING BLADE SHARPENING (FIGURE YY)

It is important to keep the "wings" on these self-scoring blades sharp. Use a file on the edge. Sharpen the flat part of the blade, the same way as described above.

## CARBIDE TIPPED BLADE SHARPENING

To sharpen carbide tipped blades, a carbide grinding wheel is necessary, ie: silicon carbide or green wheel.

## DITCHING

### CROSS ROOM DITCHING (FIGURE ZZ)

When removing hard to remove ceramic, Vct or vat, cross-room ditching will help to make the removal easier. Using a blade 2" to 6" in width, make ditches 1' to 2' apart in the same direction the machine will be removing the goods (See Figure EE). This "relieves" the pressure holding the tiles together. If ditching helps and the goods are coming up easy, try using a wider blade to ditch with.

### CHECKER BOARD DITCHING (FIGURE AA)

To make carpet removal and debris cleanup easier, checker board ditching is very helpful. Using as wide of a self-scoring blade as possible, make ditches 4' to 6' apart crossways from the way the machine will be removing the goods (See Figure FF). Running the machine crossways from the ditches will make smaller pieces of debris to be hauled away. Instead of large gummy rolls of carpet, there are small squares that can be rolled, palletized, put on a dolly or folded with the sticky side in. This makes removing the debris easier and reduces the amount of debris.

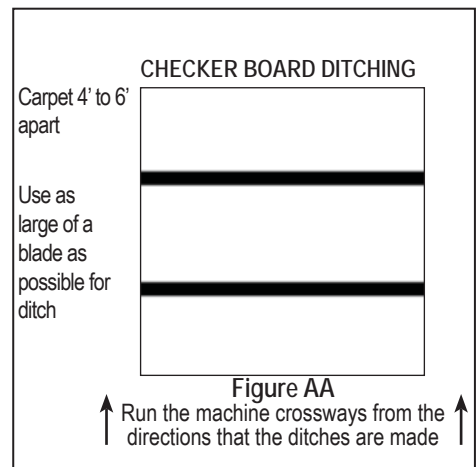
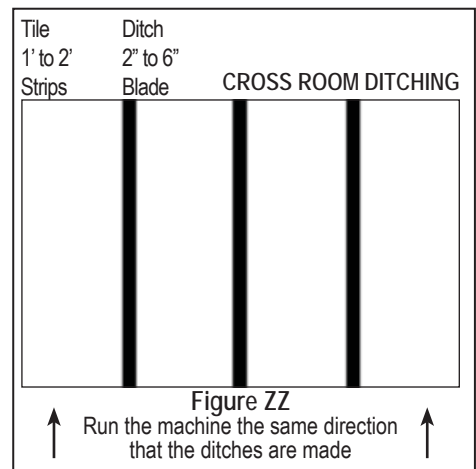

# Machine Maintenance

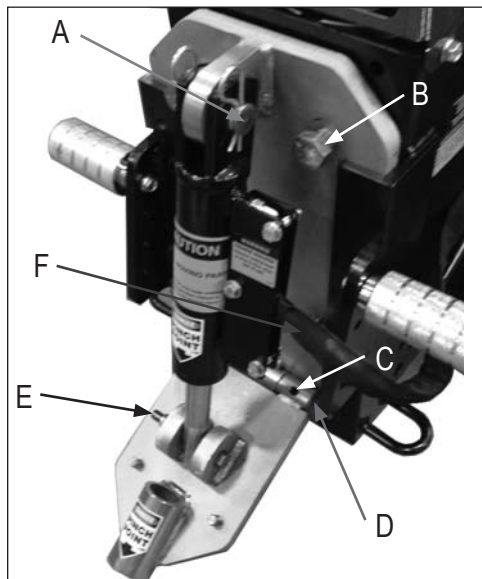

FIG. AB



**CAUTION:** ALWAYS DISCONNECT BATTERY BEFORE MAINTAINING.

## MANUAL SLIDE PLATE REMOVAL (FIGURE AB)

1. Disconnect machine from power.
2. Remove slide plate pin (A). Remove cutting head bolt (E). Remove cylinder from slide plate. Remove slide plate.

OR

1. Disconnect machine from power.
2. Disconnect hydraulic lines from cylinder (F). A small amount of oil leak out of lines. Cap lines or bleed into a container. Wipe up spillage immediately.
3. With lines removed, loosen slide plate bolts (B). Hold slide plate at the top of the cylinder.
4. Remove slide plate, cylinder and lower cutting head support.



**CAUTION:** SLIDE PLATE WILL DROP TO THE FLOOR WHEN SLIDE PLATE SECURING BOLTS ARE DISENGAGED. KEEP HANDS AND FEET OUT FROM UNDERNEATH SLIDE PLATE, FAILURE TO DO SO COULD CAUSE SEVERE BODILY INJURY.

## RAISING OR LOWERING THE SLIDE PLATE

This will only work without a cutting head inserted in the machine. Completely loosen slide plate bolts (B). Use cylinder lift lever to raise or lower machine to move slide plate up or down.

## LOWER CUTTING HEAD SUPPORT REMOVAL

1. Lower slide plate so cutting head hinge pin (D) is below machine bottom. Retighten.
2. Loosen both cutting head pin set screws (C) at the base of the lower cutting head support (hinge area).
3. Drive cutting head hinge pin (D) out using a punch and hammer.
4. Remove cylinder securing hex head bolt.

## DUAL SLIDE PLATE REMOVAL

1. Lower the slide plate to the floor and place a block under the assembly.
2. Remove the front cylinder by taking the 1/2" bolt out of the bottom and removing the pin from the top of the cylinder.
3. Remove the E-clips from the pin at the bottom of the internal cylinder, then remove the pin.
4. Remove the pin from the top of the internal cylinder and then remove the cylinder from the machine.
5. Loosen the bolt from the lower right side of the frame.
6. Remove the lock nut from securing bolts at the top of the slide plate.
7. Remove the socket head screws at the top of the dual slide from both sides of the assembly.
8. Install 3/8-16x5" bolts into the holes the socket head screws were removed from. Once installed the bolts should be used as lifting handles.
9. Lift the frame out of the machine.

# Machine Maintenance

## LEAK MAINTENANCE

All fittings on this machine are O-ring style.

1. Disconnect machine from power.
2. If a leak is detected, tighten fitting with the proper wrench size. DO NOT over tighten. Over tightening could damage O-rings.

## CHECK OIL LEVEL

1. Remove Breather Dip Stick (G).
2. Check to see that Hydraulic Fluid is visible on Dip Stick.

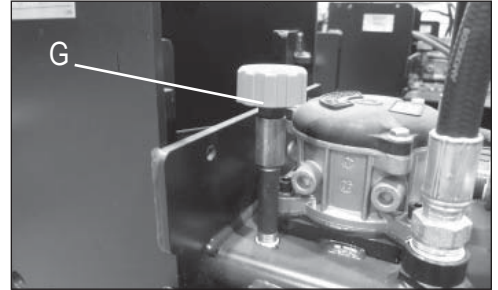

FIG. AC

OR

1. Remove Filler plug (H).
2. Oil should be visible 2" below hole.
3. Reinsert plug.

## OIL CHANGE OUT

1. Disconnect machine from power (charger or battery).
2. Drain fluid by removing the drain plug from side of tank (I).
3. Replace drain plug (I).
4. Remove filler plug (H).
5. Add oil into the filler plug hole until visual 2" below hole.

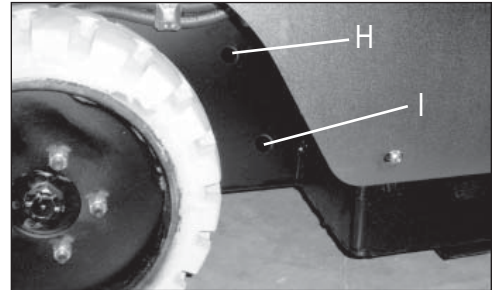

FIG. AD



**CAUTION:** THIS UNIT CONTAINS 7 ½ GALLONS OF FLUID. MAKE SURE YOU HAVE THE PROPER AMOUNT OF CONTAINERS CATCH FLUID.

## HOSE CHANGE OUT/REMOVAL

1. Disconnect machine from power.
2. Remove hood.
3. Using proper wrench size, remove hose from fitting.
4. When replacing, make sure O-ring is properly seated on hose fitting.

## WHEEL MOTOR CHANGE OUT

1. Disconnect machine from power.
2. Block up machine to remove wheel. See wheel changing on page 28.
3. Remove wheel.
4. Remove oil lines from wheel motor. A small amount of oil will run out of the lines. Drain into a container. Wipe up spills immediately.
5. Remove four 1/2" wheel motor securing nuts.
6. Pull out on wheel motor to remove.

## FOOT PEG REMOVAL/REPLACE

1. Insert a socket wrench into foot peg and secure bolt head.
2. Remove nut.
3. Remove bolt and foot peg.
4. Replace foot peg before operating machine. DO NOT use machine without foot pegs.

# Machine Maintenance

---

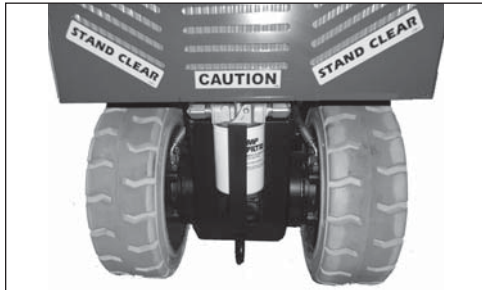

FIG. AE

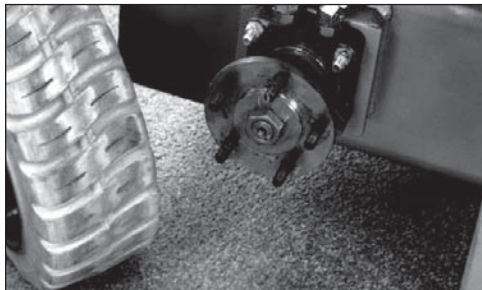

FIG. AF

## PUMP CHANGE OUT

1. Remove doghouse to expose pump.
2. Disconnect hydraulic lines.
3. Remove two 5/16" pump securing bolts.
4. Remove pump by pulling pump straight out from pump motor.

## VALVE CHANGE OUT

1. Disconnect machine from power (charger or battery).
2. Lift hood and secure in place.
3. Remove hoses from valve body. Have a container ready to catch leakage from lines.
4. Take notice of angle of valve fittings.
5. Remove two 1/4" bolts securing valve body.

## MOTOR CHANGE OUT

1. Disconnect motor from power.
2. Lift hood and secure in place.
3. Remove pump (see Pump Change Out).
4. Loosen the bracket holding the motor.
5. Remove motor.

## HYDRAULIC CYLINDER CHANGE OUT

1. Disconnect machine from power.
2. Disconnect cylinder lines. Have a container ready to catch oil from lines.
3. Remove cylinder securing hexhead bolt from lower cutting head support.
4. Remove clips and pin from cylinder and slide plate.
5. Remove cylinder upper pin.
6. Remove cylinder.

## CHANGING FILTER (FILTER SHOULD BE REPLACED YEARLY)

1. Place pan or rag below filter to catch excess hydraulic fluid.
2. Unscrew filter by hand or with wrench.
3. Use excess hydraulic fluid to lubricate seal on new filter.
4. Hand tighten replacement filter.

Do not over tighten filter, should only be hand tightened.

## REAR WHEEL CHANGING (FIG. AF)

1. Jack machine up by pushing the cylinder lift forward to lower and adjust the angle of the cutting head to raise machine.
2. Place blocks under Forklift Cups on the side of the machine that wheel is being changed.
3. Let cylinder down resting machine on blocks allowing rear wheel to be lifted off the floor.
4. Remove five 1/2" lug nuts with an extended arm wrench, remove wheel.
5. Replace wheel.
6. Replace five lug nuts and tighten, making sure lug nuts are very tight.
7. Raise cylinder to raise machine off of blocks. Remove blocks and lower machine.
8. Repeat to other side if necessary.

# Machine Maintenance

## CASTER WHEEL MAINTENANCE

1. Keep clean and free of debris, make sure it can move freely.
2. Give a shot of grease in grease fitting on caster every six months to keep moving freely.
3. To remove caster, machine will need to be raised. Push the cylinder lift lever forward to lower and adjust the angle of the cutting head to jack up the machine (Figure AG). Block up machine (Figure AH). Remove four bolts, pull caster off and clean/replace as needed.
4. Replace caster.
5. Replace and firmly tighten the four bolts.
6. Lower the machine.

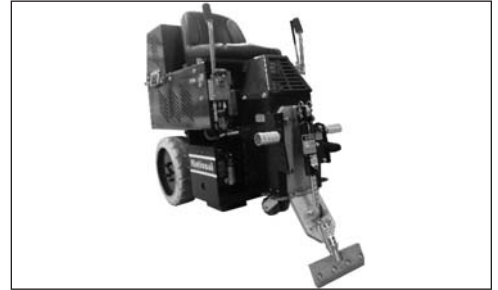

FIG. AG

## SEAT REPLACEMENT

1. Remove four (4) hexhead screws on each side of the hood (4 times).
2. Slightly raise seat plate & unplug wire harness.
3. Lift hood off.
4. Remove seat.
5. To replace seat, set seat on top of hood.
6. Replace the four 3/8" x 16" x 3/4" hexhead screws from underneath the hood.
7. Firmly tighten.
8. Reconnect back-up beeper and seat switch wires.
9. Replace hood and screws.

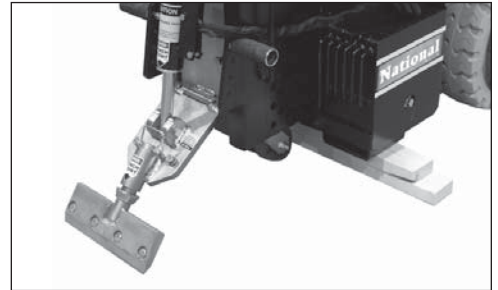

FIG. AH

## DEBRIS DEFLECTOR (FIGURE AI)

1. Place the debris deflector under the lower cutting head support and align with the two threaded holes.
2. Firmly secure debris deflector under the cutting head with the two bolts supplied.

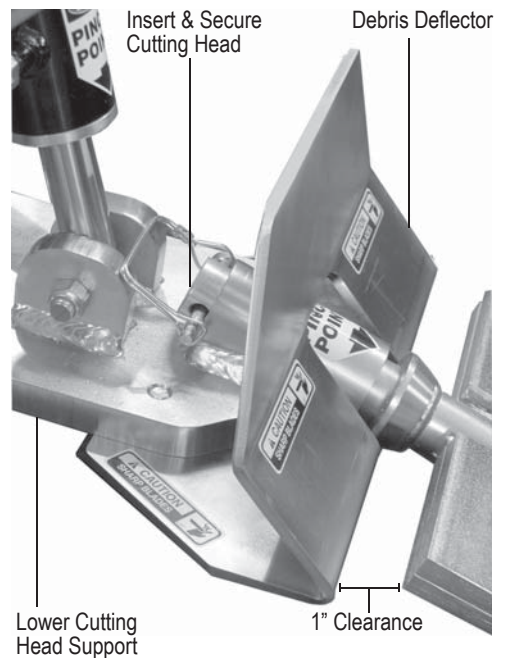

FIG. AI



**WARNING:** DO NOT ALTER A SWITCH OR LEVER. DO NOT DEFEAT A SAFETY DEVICE.



**WARNING:** THE BACK-UP BEEPER IS ON THE MACHINE FOR SAFETY. IT IS IMPORTANT TO KEEP IT IN GOOD WORKING CONDITION. FAILURE TO DO SO COULD CAUSE BODILY INJURY.

# Troubleshooting Guide

Problem	Cause	Solution
Machine will not start.	Seat Safety Switch is engaged.	Make sure that you're sitting on seat.
	Emergency Stop (E-Stop) switch is engaged.	Twist E-Stop switch to expose green ring.
	Circuit breaker is in the OFF position.	Verify circuit breaker is in ON position.
	48 volt blue plugs are not connected.	Make sure that connection plugs are fully installed.
	"Start" button did not fully engage.	Firmly press down green start button.
Machine doesn't run as long as it used to.	Battery is not fully charging.	Verify that you are charging machine with provided seven foot power cord. Verify that charger is working properly. Charger has a LED light to indicate.
	The 48 volt blue plugs are not connected.	Check that connection plugs are fully installed.
	Batteries no longer hold a charge.	Call National for procedure to have batteries load tested.
Machine is making rattling noises.	Loose hardware on machine.	Inspect and tighten bolts as needed.
Charger is hot.	Charger is in use.	This is normal.
Fluid is leaking from machine.	Hose connections/or fittings have loosened through normal use.	Tighten hydraulic hoses and fittings as needed.
	Pin hole in the hoses.	Replace affected hose.
	Oil and/or oil filter are old.	Replace oil and oil filter yearly on machine.
Tires/Wheel motors make a slight clicking noise.		Normal noise with proper operation.
Machine is jerky or jumpy.	New operator	Additional time is required to become familiar with machine.
	Control levers are being moved to quickly.	Operate control levers with wrist resting on knees for additional support or purchase arm rest.
Coupling leaks at thread or seat.	Missing or damaged O-rings.	Check for missing or damaged O-rings; replace if necessary.
	Damaged threads due to misalignment or improper seat angle.	Correct seat angle. Check for thread damage; replace if necessary.
	Over or under torquing.	Only hand tighten hardware.
Any issues not listed above.		Please contact National to speak with a technician.

# Complete Parts List

PART#	DESCRIPTION	QTY	PART#	DESCRIPTION	QTY
1	70354 HOSE, 3/4", RETURN LINE TO TANK	1	55	5110-218 SWITCH, BACK UP BEEPER	1
2	70355 HOSE, 3/4", RETURN LINE TO FILTER	1	56	5110-234 COUPLER, RELIEF VALVE	1
3	70602 TUBE, INSTRUCTION MANUAL	1	57	5110-234-1 PIPE, RELIEF VALVE	1
4	70603 CAP, INSTRUCTION TUBE	1	58	5110-237 FILTER SCREEN	2
5	70651 PLUG, VALVE BODY	4	59	5110-250 CYLINDER NN16	1
6	70653 FITTING, 90 DEGREE	2	60	5110-251 ROD, CYLINDER CONNECT	1
7	70654 FITTING, REDUCER	1	61	5110-267 HOSE, CYLINDER	1
8	71703 PROTECTOR, BATTERY TERMINAL, RED	3	62	5110-268 FITTING, VALVE STRAIGHT	2
9	72385 MOTOR, 4 HP, XP2135	1	63	5110-405 WHEEL, RIM & TIRE 18"	2
10	72705 PLUG, 48V	1	64	5200-116 BEEPER, BACK UP	1
11	72801 FITTING, 90 DEGREE, 1/4"	2	65	5200-118-8 CONNECTOR, BLUE 48V BATTERY	2
12	72816 FITTING, ELBOW, 90 DEGREE, 3/8"	8	66	5200-118-9 CONNECTOR, BLUE 48V BATTERY	2
13	72834 PROTECTOR, SMALL	2	67	5200-127 STRIP, ELECTRICAL	1
14	73047 KEY, WOODRUFF 1/4 X 1	1	68	5200-18 CLAMP, FRONT MOTOR	2
15	73131 PIN, KOTTER 3/32X1 3/4	2	69	5200-194 CASTER, DOUBLE GRAY	1
16	73201 SCREW, HEX HEAD CAP 3/8 16X1	2	70	5200-1G GASKET, PUMP	1
17	73204 WASHER, SPLIT LOCK 3/8	4	71	5200-258 DEFLECTOR, DEBRIS	1
18	73205 BOLT, HEX HEAD CAP 3/8 16X3/4	2	72	5200-261 HOSE, WHEEL MOTOR	4
19	73207 NUT, NYLOCK 3/8 16	2	73	5200-261-1A CLAMP	2
20	73212 BOLT, BUTTON HEAD CAP 3/8 16X1/2	2	74	5200-30 DOGHOUSE BASE, ASSEMBLY	1
21	73238 BOLT, FLANGE 3/8 16X1 1/2	2	75	5200QL-1A PLATE, HYDRAULIC PUMP ADAPTOR	1
22	73242 SCREW, BH CAP WITH FLANGE 3/8 16 X 1	4	76	5213-2 BATTERY, 8 VOLT, 2900	12
23	73248 SCREW, SET 3/8 16X1/4	2	77	5700-100 WIRE SET (PARTIAL SHOWN)	1
24	73263 WASHER, FLAT SEA ZINC 3/8	2	78	5700-102 SWITCH, E STOP	1
25	73270 PIN, 3/8 X 3	1	79	5700-103 SWITCH, START	1
26	73322 NUT, NYLOCK 5/16 18	2	80	5700-104 CONTACTOR	1
27	73334 BOLT, HEX HEAD CAP 5/16 18X1 1/2	3	81	5700-106 BREAKER, CIRCUIT, 70 AMP	1
28	73402 NUT, NYLOCK 1/2 13	1	82	5700-13 TUB, COVER FRONT	1
29	73403 WASHER, SPLIT LOCK 1/2	9	83	5700-18 BATTERY HOLD DOWN	3
30	73406 SCREW, CAP HEXHEAD 1/2-13 X 1-1/4	1	84	400154 TUB WELDMENT	1
31	73414 BOLT, HEX HEAD 1/2 13X7	1	85	400155 COVER, BATTERY, UPPER	1
32	73424 WASHER, FLAT, ZINC SAE 1/2	7	86	5700-21 TRAY, BATTERY, UPPER	1
33	73427 BOLT, HEX HEAD CAP 1/2 13X1 1/2	6	87	5700-30 EXTENSION, DOGHOUSE	1
34	73430 NUT, NYLOCK 1/2 20	10	88	5700-35 SPACER, MOTOR	2
35	73536 PIN, HITCH CLIP 5/8"	2	89	5700-36 GUARD, HOSE	2
36	73605 BOLT, HEX HEAD, GRADE 8, 3/4 10X1 1/2	4	90	5700-41 HANDLE, WELDMENT RIGHT	1
37	74425 NUT, KEPS LOCK 10 32	2	91	5700-42 HANDLE, WELDMENT LEFT	1
38	74517 SCREW, PHILLIPS PAN HEAD MAC 6 32X1	2	92	5700-56 SPACER, BATTERY	4
39	74834 FITTING, 90 DEG	2	93	5700-62 HOLDOWN BAR COVER	3
40	74854 WEIGHT, 36 LB. REMOVABLE	5	94	5700-64 FITTING, FILTER	1
41	400132 BOLT, HEX HEAD, 1/2 13 X 3 1/2	1	95	5700-65 FILTER	1
42	400133 MOTOR, WHEEL, HYDRAULIC, 10MM BOLT2	1	96	5700-66 FILTER HEAD	1
43	401553 BATTERY CHARGER, INBOARD	1	97	5700-67 PLUG, TANK	1
44	5110-111 SEAT, RIDE ON	1	98	5700-70 T FITTING	1
45	5110-114-2 FITTING, WHEEL MOTOR	4	99	5700-71 HOSE, RETURN RIGHT	1
46	5110-115 SPOOL CONTROL, SINGLE	1	100	5700-72 HOSE, RETURN LEFT	1
47	5110-116 SPOOL CONTROL, DOUBLE	1	101	5700-76 HOSE, 25"	2
48	5110-117 WHEEL, HUB	2	102	5700-77 ASSEMBLY, HOSE	1
49	5110-117-2 NUT, HUB	2	103	5700-79 HARNESS, SEAT	1
50	5110-157 PLUG, DRAIN FILLER	2	104	5700-80 HARNESS, MAIN	1
51	5110-166 PLATE, SLIDE	1	105	5700-81 HOSE, SUCTION LINE	1
52	5110-167 SUPPORT, LOWER CUTTING HEAD	1	106	5700-85 COVER, TERMINAL STRIP	1
53	5110-170 PIN, CUTTING HEAD	1	107	5700-89 HANDLE, CHEST	2
54	5110-180 PEG, FOOT	2	108	5700-90 RELAY, SOCKET	1

# Complete Parts List

PART#	DESCRIPTION	QTY	PART#	DESCRIPTION	QTY
109	5700-91 RELAY	1	123	L309 LABEL, "A" (ON BATTERY, NOT SHOWN)	6
110	6280-118 FITTING, SUCTION HOSE TO PUMP	2	124	L310 LABEL, "B" (ON BATTERY, NOT SHOWN)	6
111	70905-D4 PUMP, DOUBLE, MARZOCCHI	1	125	L311-2 LABEL, BATTERY (NOT SHOWN)	12
112	L08-1 LABEL, STAND CLEAR	2	126	L33B LABEL, CAUTION MOVING PART	1
113	L106 LABEL, PINCH POINT	2	127	L33C LABEL, INSTRUCTION MANUAL	1
114	L118 LABEL, OPERATOR MUST BE SEATED	2	128	L33D LABEL, AUTHORIZED PERSONEL ONLY	1
115	L127 LABEL, CAUTION OPERATING	1	129	L37 LABEL, CAUTION SHARP BLADES	4
116	L137 LABEL, DISARM MACHINE	3	130	L38 LABEL, DISCONNECT POWER	1
117	L141 LABEL, FLAG MADE IN US	2	131	L66 LABEL, LARGE CAUTION	1
118	L155 LABEL, GENERAL WARNING	1	132	L95F LABEL, FLUID LEAK	2
119	L176 LABEL, NATIONAL	3	133	L98 LABEL, BLADE LIFT	1
120	L223 LABEL, PATENT NUMBER (NOT VISIBLE)	1			
121	L305 LABEL, DO NOT GET CHARGER WET	1			
122	L308 LABEL, 5700	2			



# Parts List and Diagrams

## EXTERNAL PARTS

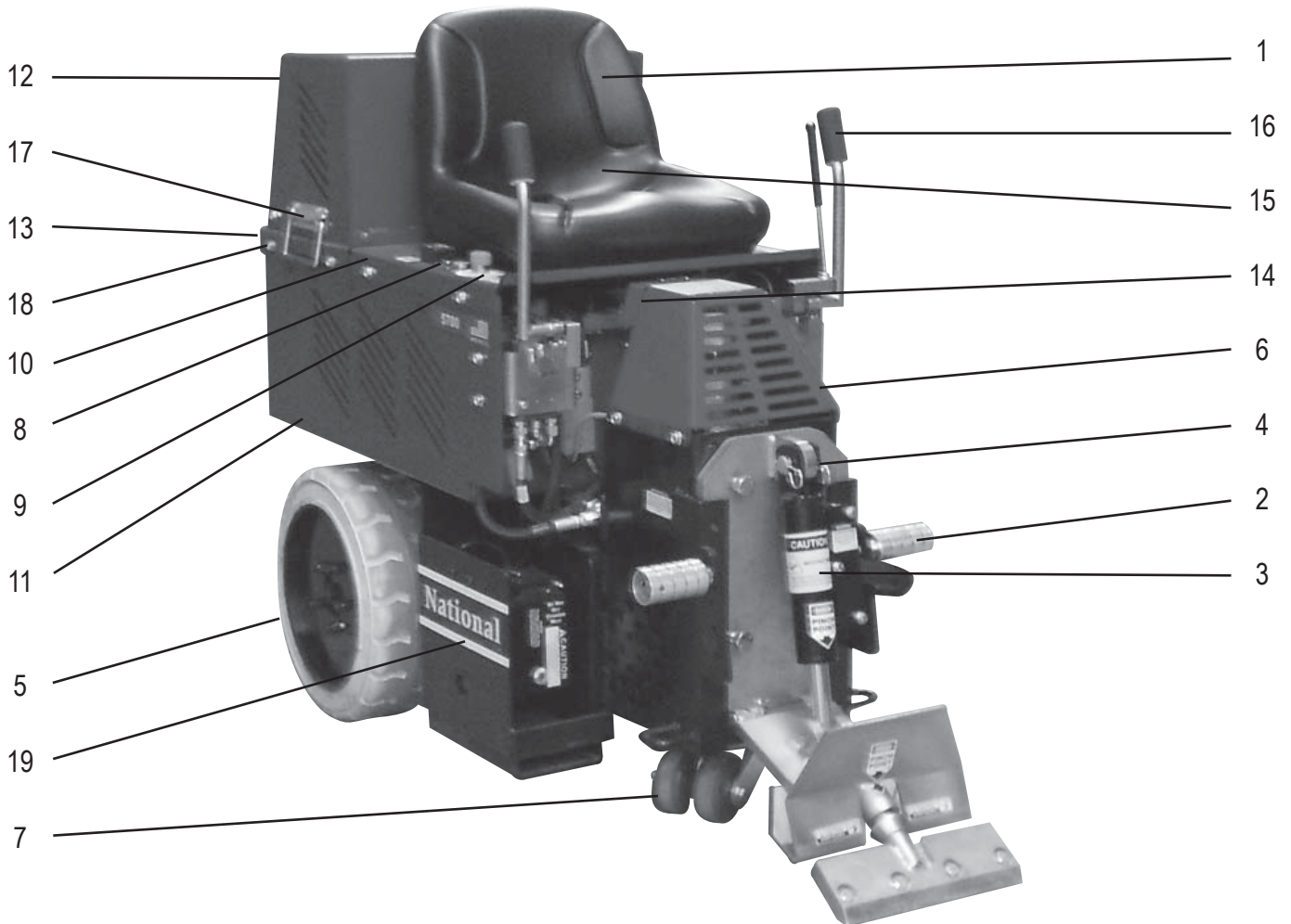

PART#	DESCRIPTION	QTY	PART#	DESCRIPTION	QTY
1	5110-111 SEAT, RIDE ON	1	11	400154 TUB WELDMENT	1
2	5110-180 PEG, FOOT	2	12	400155 COVER, BATTERY, UPPER	1
3	5110-250 CYLINDER NN16	1	13	5700-21 TRAY, BATTERY, UPPER	1
4	5110-251 ROD, CYLINDER CONNECT	1	14	5700-30 EXTENSION, DOGHOUSE	1
5	5110-405 WHEEL, RIM & TIRE 18"	2	15	5700-41 HANDLE, WELDMENT RIGHT	1
6	5200-30 DOGHOUSE BASE, ASSEMBLY	1	16	5700-42 HANDLE, WELDMENT LEFT	1
7	5200-194 CASTER, DOUBLE GRAY	1	17	5700-89 HANDLE, CHEST	2
8	5700-103 SWITCH, START	1	18	73212 BOLT, BUTTON HEAD CAP 3/8 16X1/2	2
9	5700-102 SWITCH, E STOP	1	19	401553 BATTERY CHARGER, INBOARD	1
10	5700-13 TUB, COVER FRONT	1			

# Parts List and Diagrams

## CYLINDER ASSEMBLY

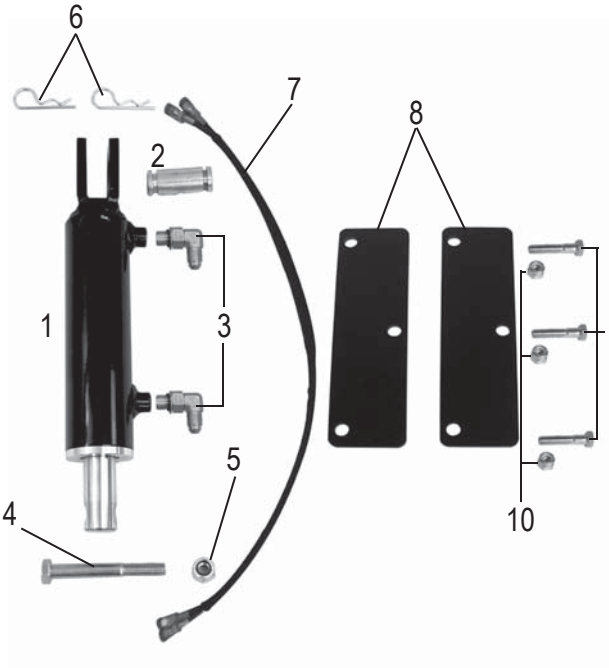

	PART#	DESCRIPTION	QTY
1	5110-250	CYLINDER NN16	1
2	5110-251	ROD, CYLINDER CONNECT	1
3	72801	FITTING, 90 DEGREE, 1/4"	2
4	400132	BOLT, HEX HEAD, 1/2 13 X 3 1/2	1
5	73402	NUT, NYLOCK 1/2 13	1
6	73536	PIN, HITCH CLIP 5/8"	2
7	5110-267	HOSE, CYLINDER	1
8	5700-36	GUARD, HOSE	2
9	73334	BOLT, HEX HEAD CAP 5/16 18X1 1/2	3
10	73322	NUT, NYLOCK 5/16 18	2

## SLIDE PLATE ASSEMBLY

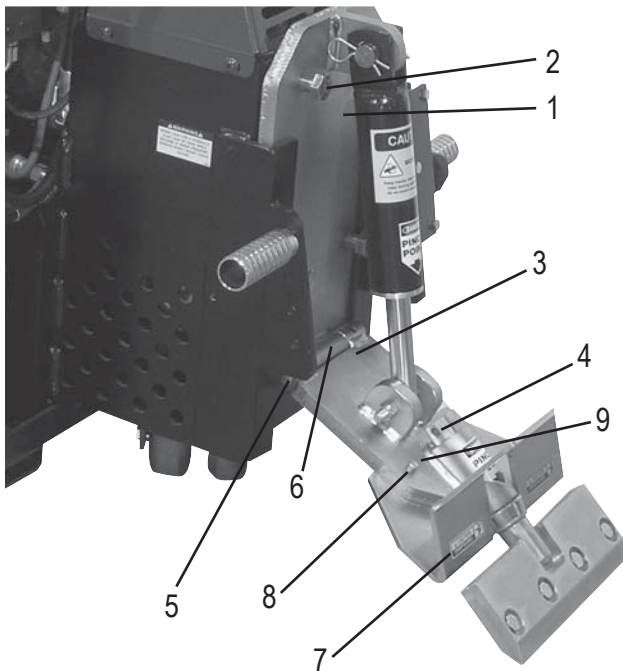

	PART#	DESCRIPTION	QTY
1	5110-166	PLATE, SLIDE	1
2	73605	BOLT, HEX HEAD, GRADE 8, 3/4 10X1 1/2	4
3	5110-167	SUPPORT, LOWER CUTTING HEAD	1
4	73270	PIN, 3/8 X 3	1
5	5110-170	PIN, CUTTING HEAD	1
6	73248	SCREW, SET 3/8 16X1/4	2
7	5200-258	DEFLECTOR, DEBRIS	1
8	73403	WASHER, SPLIT LOCK 1/2	2
9	73427	BOLT, HEX HEAD CAP 1/2 13X1 1/2	2

# Parts List and Diagrams

PART#	DESCRIPTION	QTY	
1	5200-194	CASTER, DOUBLE GRAY	1
2	73427	BOLT, HEX HEAD CAP 1/2 13X1 1/2	4
3	73424	WASHER, FLAT, ZINC SAE 1/2	4
4	73403	WASHER, SPLIT LOCK 1/2	4

## CASTER WHEEL ASSEMBLY

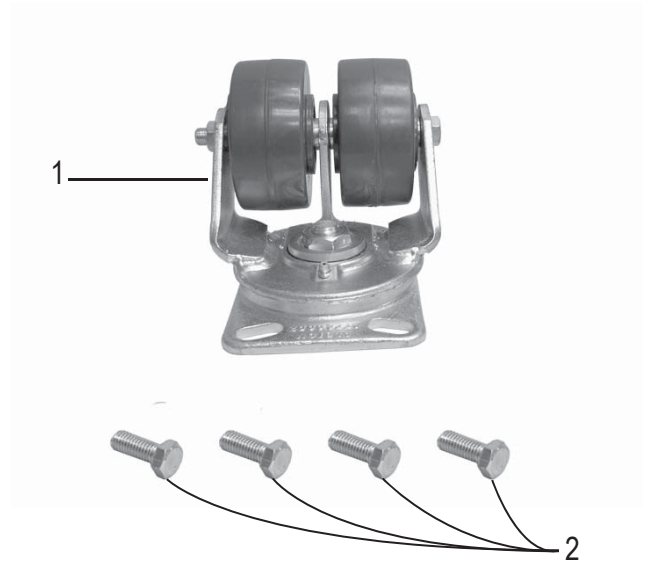

PART#	DESCRIPTION	QTY	
1	400133	MOTOR, WHEEL, HYDRAULIC, 10MM BOLT2	1
2	5110-114-2	FITTING, WHEEL MOTOR	4
3	5110-117	WHEEL, HUB	2
4	5110-117-2	NUT, HUB	2
5	5200-261-1A	CLAMP	2
6	73047	KEY, WOODRUFF 1/4 X 1	1
7	73131	PIN, KOTTER 3/32X1 3/4	2
8	73430	NUT, NYLOCK 1/2 20	10
9	5110 405	WHEEL, RIM & TIRE 18" (NOT SHOWN)	2

## REAR WHEEL ASSEMBLY

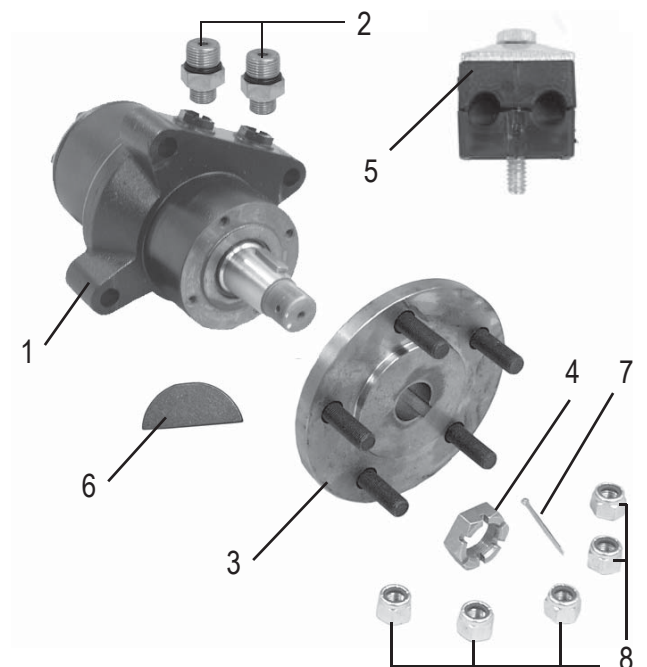

# Parts List and Diagrams

## ELECTRICAL BOX ASSEMBLY

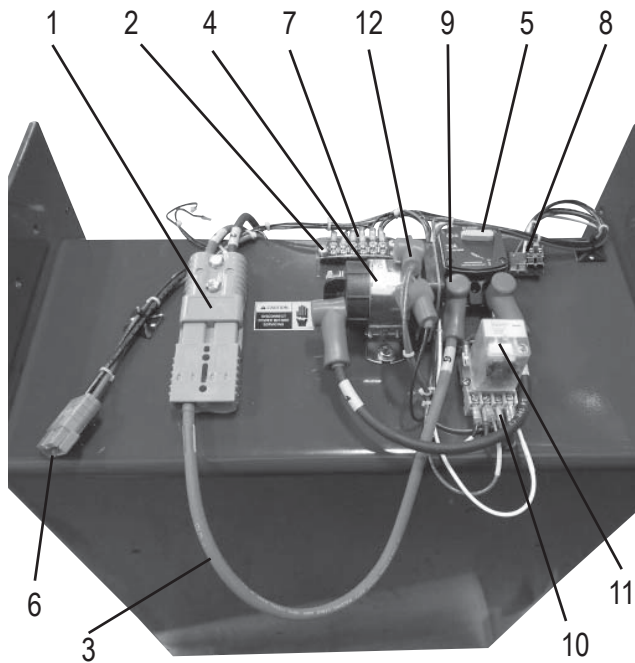

PART#	DESCRIPTION	QTY
1	5200-118-8 CONNECTOR, BLUE 48V BATTERY	2
2	5200-127 STRIP, ELECTRICAL	1
3	5700-100 WIRE SET (PARTIAL SHOWN)	1
4	5700-104 CONTACTOR	1
5	5700-106 BREAKER, CIRCUIT, 70 AMP	1
6	72705 PLUG, 48V	1
7	5700-85 COVER, TERMINAL STRIP	1
8	5700-80 HARNESS, MAIN	1
9	71703 PROTECTOR, BATTERY TERMINAL, RED	3
10	5700-90 RELAY, SOCKET	1
11	5700-91 RELAY	1
12	72834 PROTECTOR, SMALL	2

## BATTERY

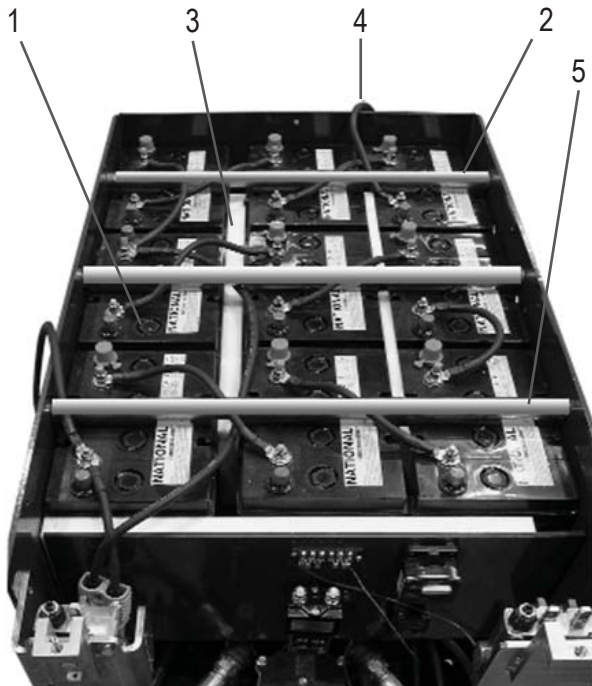

PART#	DESCRIPTION	QTY
1	5213-2 BATTERY, 8 VOLT, 2900	12
2	5700-18 BATTERY HOLD DOWN	3
3	5700-56 SPACER, BATTERY	4
4	5700-100 WIRE SET (PARTIAL SHOWN)	1
5	5700-62 HOLDOWN BAR COVER	3

# Parts List and Diagrams

PART#	DESCRIPTION	QTY
1 5200-116	BEEPER, BACK UP	1

## BACKUP BEEPER ASSEMBLY



PART#	DESCRIPTION	QTY
1 5110-218	SWITCH, BACK UP BEEPER	1
2 74517	SCREW, PHILLIPS PAN HEAD MAC 6 32X1 2	2

## HANDLE SWITCH (FOR BEEPER)

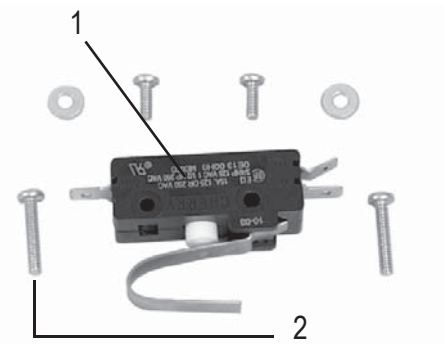

PART#	DESCRIPTION	QTY
1 70602	TUBE, INSTRUCTION MANUAL	1
2 70603	CAP, INSTRUCTION TUBE	1
3 74425	NUT, KEPS LOCK 10 32	2

## INSTRUCTION TUBE ASSEMBLY

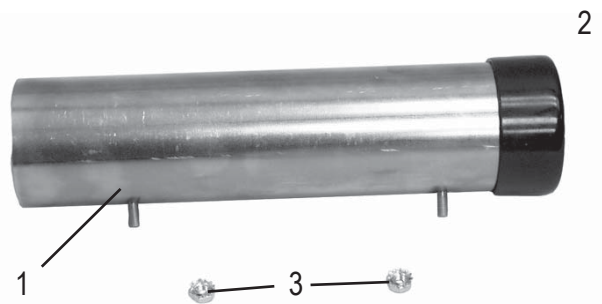

PART#	DESCRIPTION	QTY
1 5110-180	PEG, FOOT	2
2 73238	BOLT, FLANGE 3/8 16X1 1/2	2
3 73207	NUT, NYLOCK 3/8 16	2

## FOOT PEG ASSEMBLY

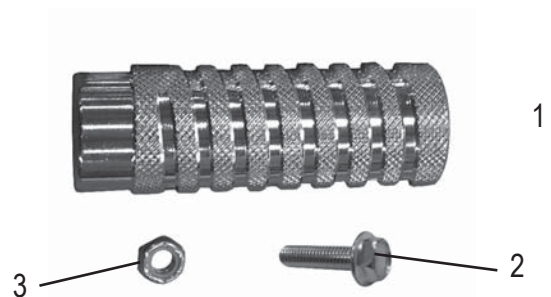

# Parts List and Diagrams

## SPOOL AND HOSE PARTS

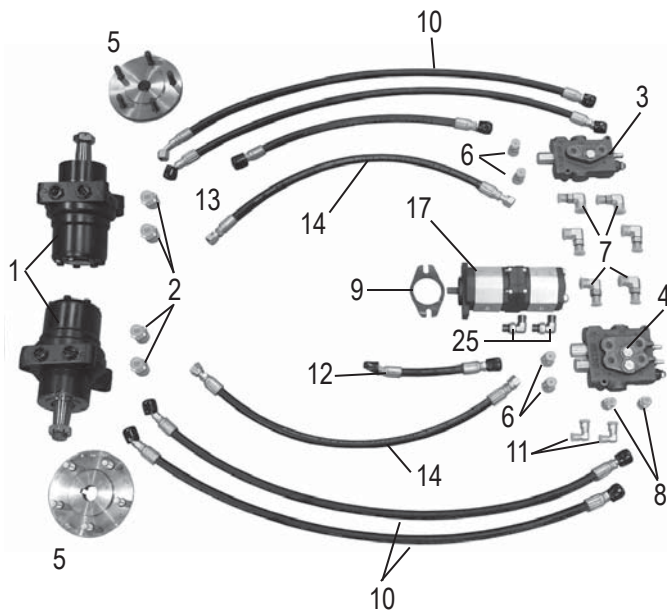

PART#	DESCRIPTION	QTY
1	400133 MOTOR, WHEEL, HYDRAULIC, 10MM BOLT2	
2	5110-114-2 FITTING, WHEEL MOTOR	4
3	5110-115 SPOOL CONTROL, SINGLE	1
4	5110-116 SPOOL CONTROL, DOUBLE	1
5	5110-117 WHEEL, HUB	2
6	70651 PLUG, VALVE BODY	4
7	72816 FITTING, ELBOW, 90 DEGREE, 3/8"	6
8	5110-268 FITTING, VALVE STRAIGHT	2
9	5200-1G GASKET, PUMP	1
10	5200-261 HOSE, WHEEL MOTOR	4
11	74834 FITTING, 90 DEG	2
12	5700-71 HOSE, RETURN RIGHT	1
13	5700-72 HOSE, RETURN LEFT	1
14	5700-76 HOSE, 25"	2
15	5700-77 ASSEMBLY, HOSE	1
16	5700-81 HOSE, SUCTION LINE	1
17	70905-D4 PUMP, DOUBLE, MARZOCCHI	1
18	5700-65 FILTER	1
19	5700-66 FILTER HEAD	1
20	70653 FITTING, 90 DEGREE	2
21	70354 HOSE, 3/4", RETURN LINE TO TANK	1
22	70355 HOSE, 3/4", RETURN LINE TO FILTER	1
23	5110-250 CYLINDER NN16	1
24	5110-267 HOSE, CYLINDER	1
25	6280-118 FITTING, SUCTION HOSE TO PUMP	2
26	5110-237 FILTER SCREEN	2
27	5110-234 COUPLER, RELIEF VALVE	1
28	5110-234-1 PIPE, RELIEF VALVE	1
29	5110-157 PLUG, DRAIN FILLER	2
30	5700-64 FITTING, FILTER	1
31	5700-67 PLUG, TANK	1
32	70654 FITTING, REDUCER	1
33	5700-70 T FITTING	1

## FILTER AND TANK PARTS

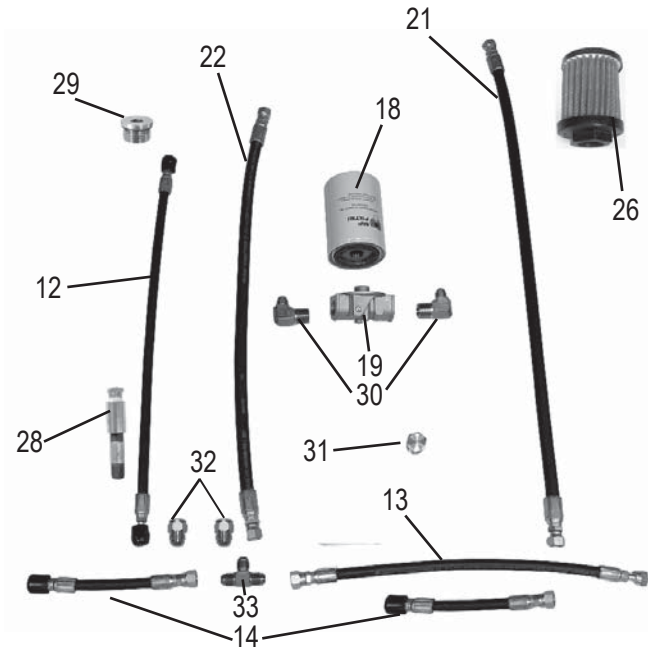

# Parts List and Diagrams

## HYDRAULIC FLOW DIAGRAM

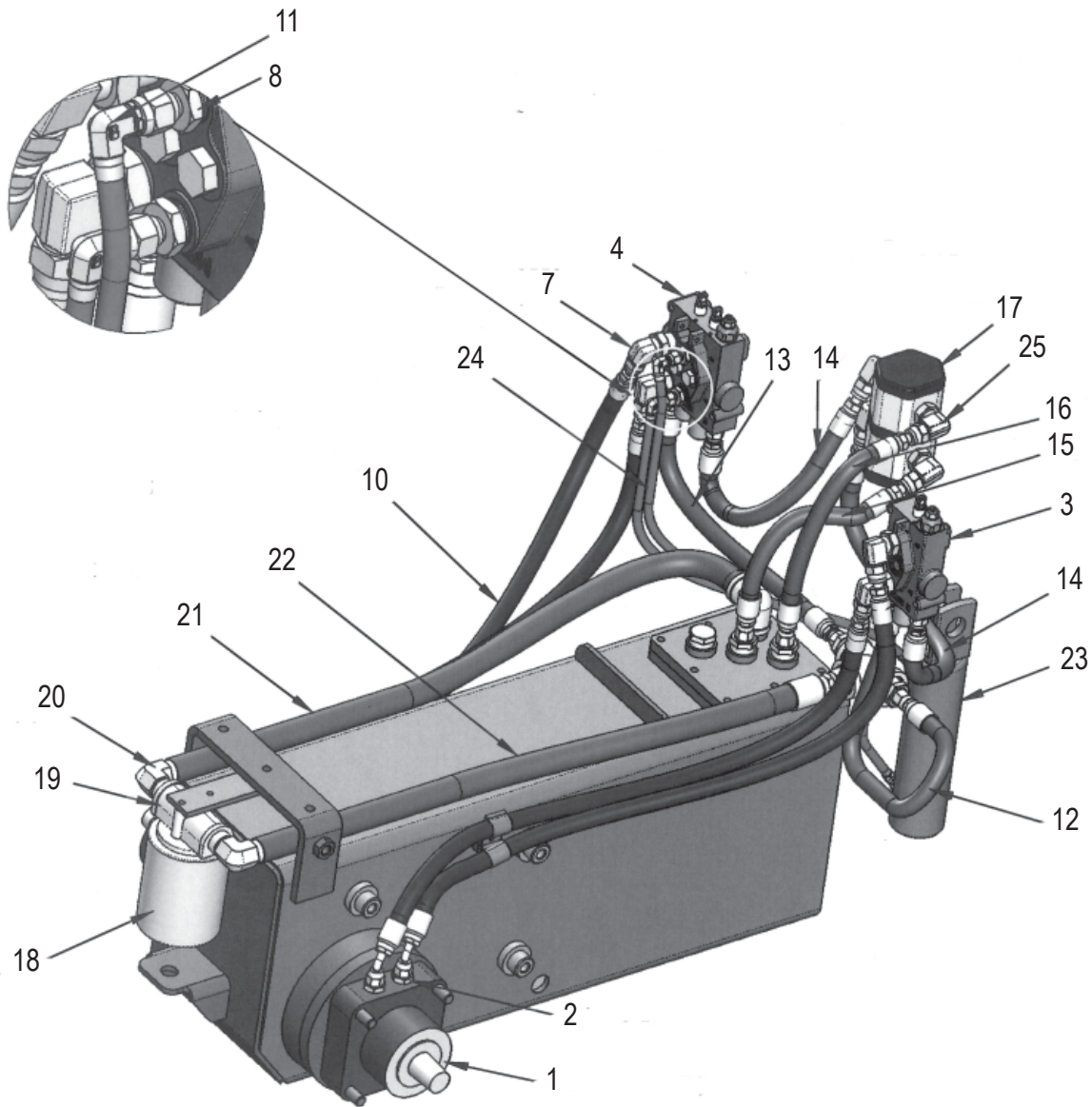

THE ASSOCIATED NUMBERS FOR THESE CALLOUTS ARE ON PAGE 38

# Parts List and Diagrams

## MOTOR PARTS

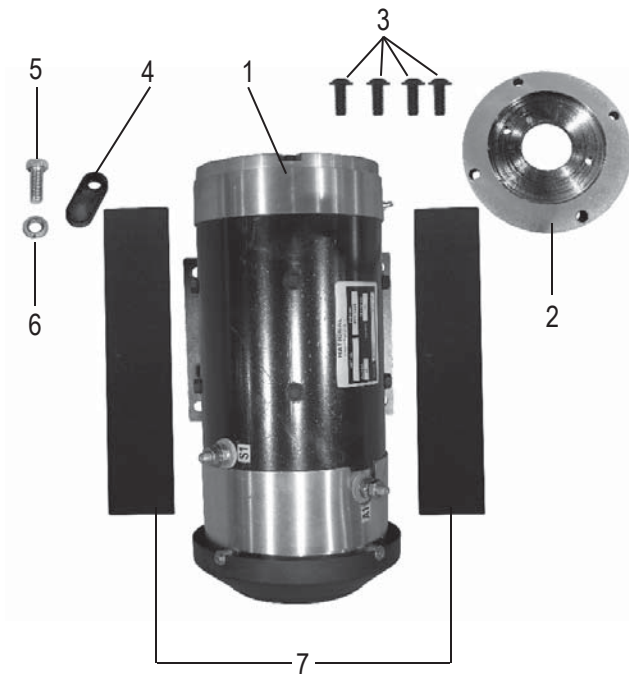

PART#	DESCRIPTION	QTY
1	72385 MOTOR, 4 HP, XP2135	1
2	5200QL-1A PLATE, HYDRAULIC PUMP ADAPTOR	1
3	73242 SCREW, BH CAP WITH FLANGE 3/8 16 X 1	4
4	5200-18 CLAMP, FRONT MOTOR	2
5	73201 SCREW, HEX HEAD CAP 3/8 16X1	2
6	73204 WASHER, SPLIT LOCK 3/8	2
7	5700-35 SPACER, MOTOR	2

## GEAR PUMP ASSEMBLY

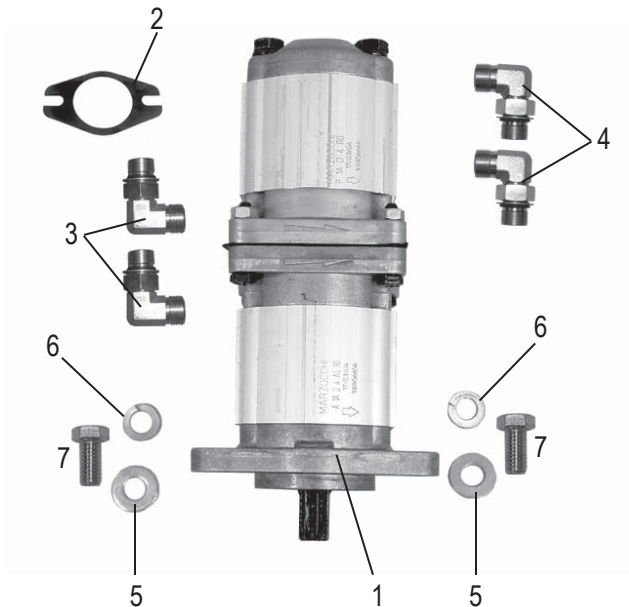

PART#	DESCRIPTION	QTY
1	70905-D4 PUMP, DOUBLE, MARZOCCHI	1
2	5200-1G GASKET, PUMP	1
3	72816 FITTING, ELBOW, 90 DEGREE, 3/8"	2
4	6280-118 FITTING, SUCTION HOSE TO PUMP	2
5	73263 WASHER, FLAT SEA ZINC 3/8	2
6	73204 WASHER, SPLIT LOCK 3/8	2
7	73205 BOLT, HEX HEAD CAP 3/8 16X3/4	2

FOR 5700-HS ONLY

70905-D5	PUMP, DOUBLE, MARZOCCHI (FOR -HS)	1
----------	-----------------------------------	---



# Parts List and Diagrams

PART#	DESCRIPTION	QTY
1	L08-1 LABEL, STAND CLEAR	2
2	L106 LABEL, PINCH POINT	2
3	L118 LABEL, OPERATOR MUST BE SEATED	2
4	L127 LABEL, CAUTION OPERATING	1
5	L137 LABEL, DISARM MACHINE	3
6	L141 LABEL, FLAG MADE IN US	2
7	L155 LABEL, GENERAL WARNING	1
8	L176 LABEL, NATIONAL	3
9	L223 LABEL, PATENT NUMBER (NOT VISIBLE)	1
10	L305 LABEL, DO NOT GET CHARGER WET	1
11	L308 LABEL, 5700	2
12	L309 LABEL, "A" (ON BATTERY, NOT SHOWN)	6
13	L310 LABEL, "B" (ON BATTERY, NOT SHOWN)	6
14	L311-2 LABEL, BATTERY (NOT SHOWN)	12
15	L33B LABEL, CAUTION MOVING PART	1
16	L33C LABEL, INSTRUCTION MANUAL	1
17	L33D LABEL, AUTHORIZED PERSONEL ONLY	1
18	L37 LABEL, CAUTION SHARP BLADES	4
19	L38 LABEL, DISCONNECT POWER	1
20	L66 LABEL, LARGE CAUTION	1
21	L95F LABEL, FLUID LEAK	2
22	L98 LABEL, BLADE LIFT	1

## LABELS

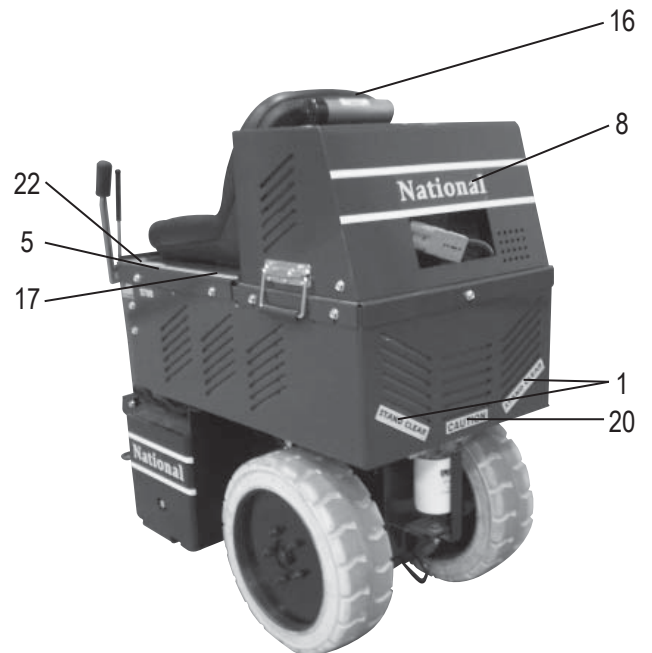
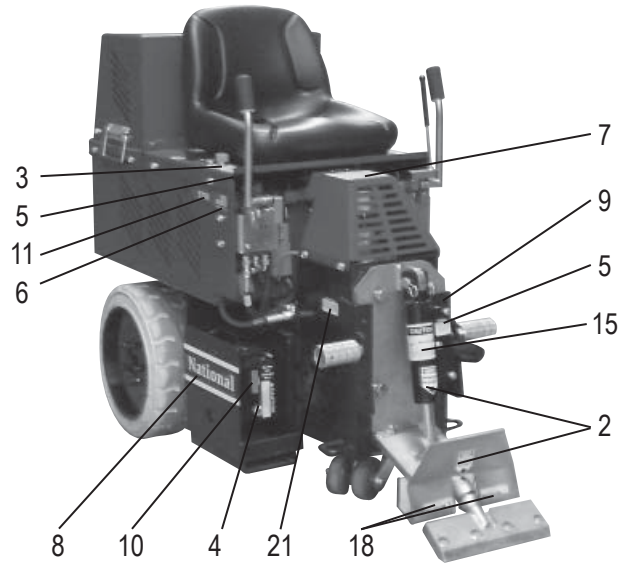

# Parts List and Diagrams

---

## WEIGHTS



	PART#	DESCRIPTION	QTY
1	74854	WEIGHT, 36 LB. REMOVABLE	5
2	73424	WASHER, FLAT, ZINC SAE 1/2	7
3	73403	WASHER, SPLIT LOCK 1/2	7
4	73414	BOLT, HEX HEAD 1/2 13X7	1
5	73406	SCREW, CAP HEXHEAD 1/2-13 X 1-1/4	1

# Parts List and Diagrams

## 5700 BATTERY WIRING

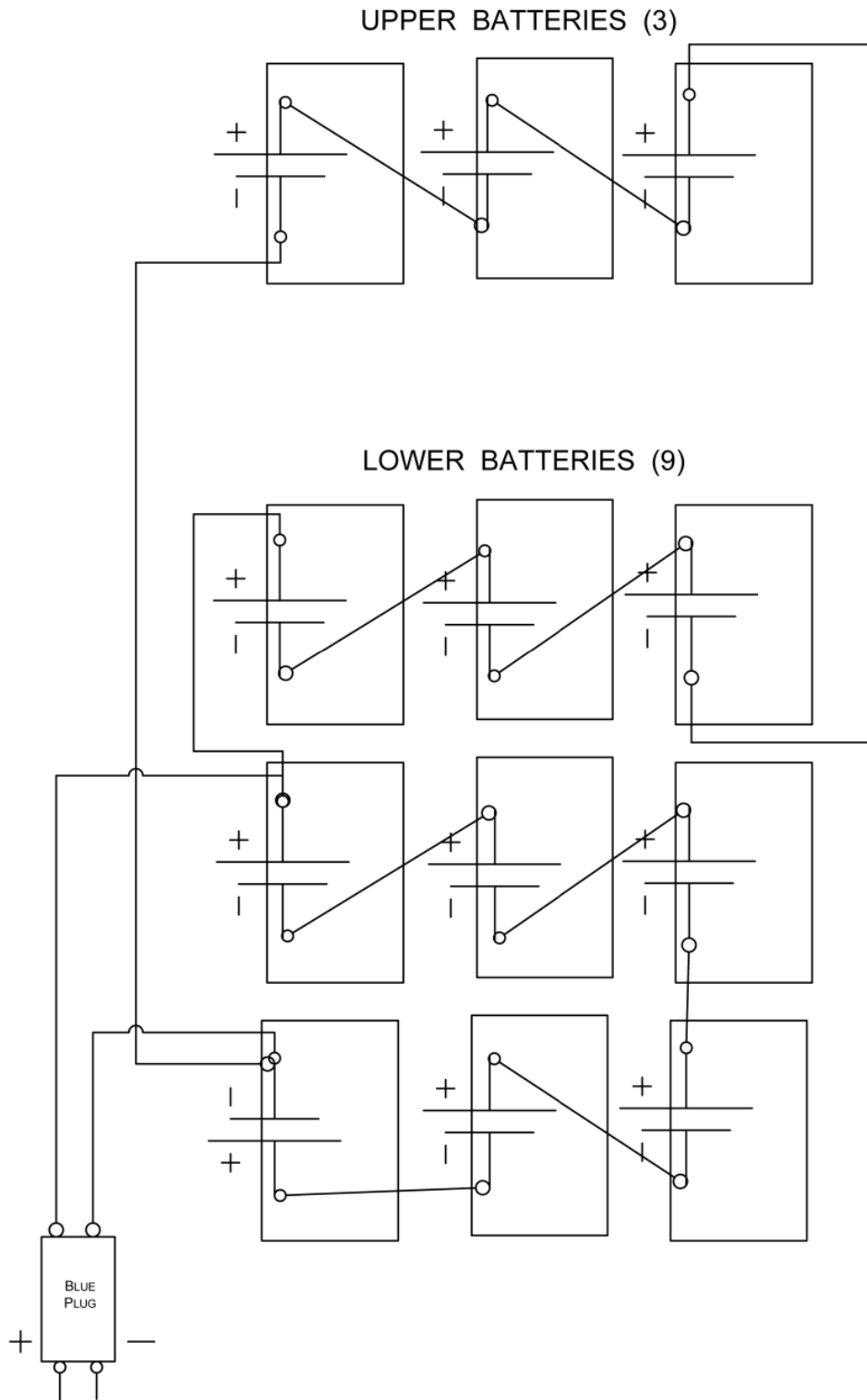

# Parts List and Diagrams

## 5700 SEAT WIRING

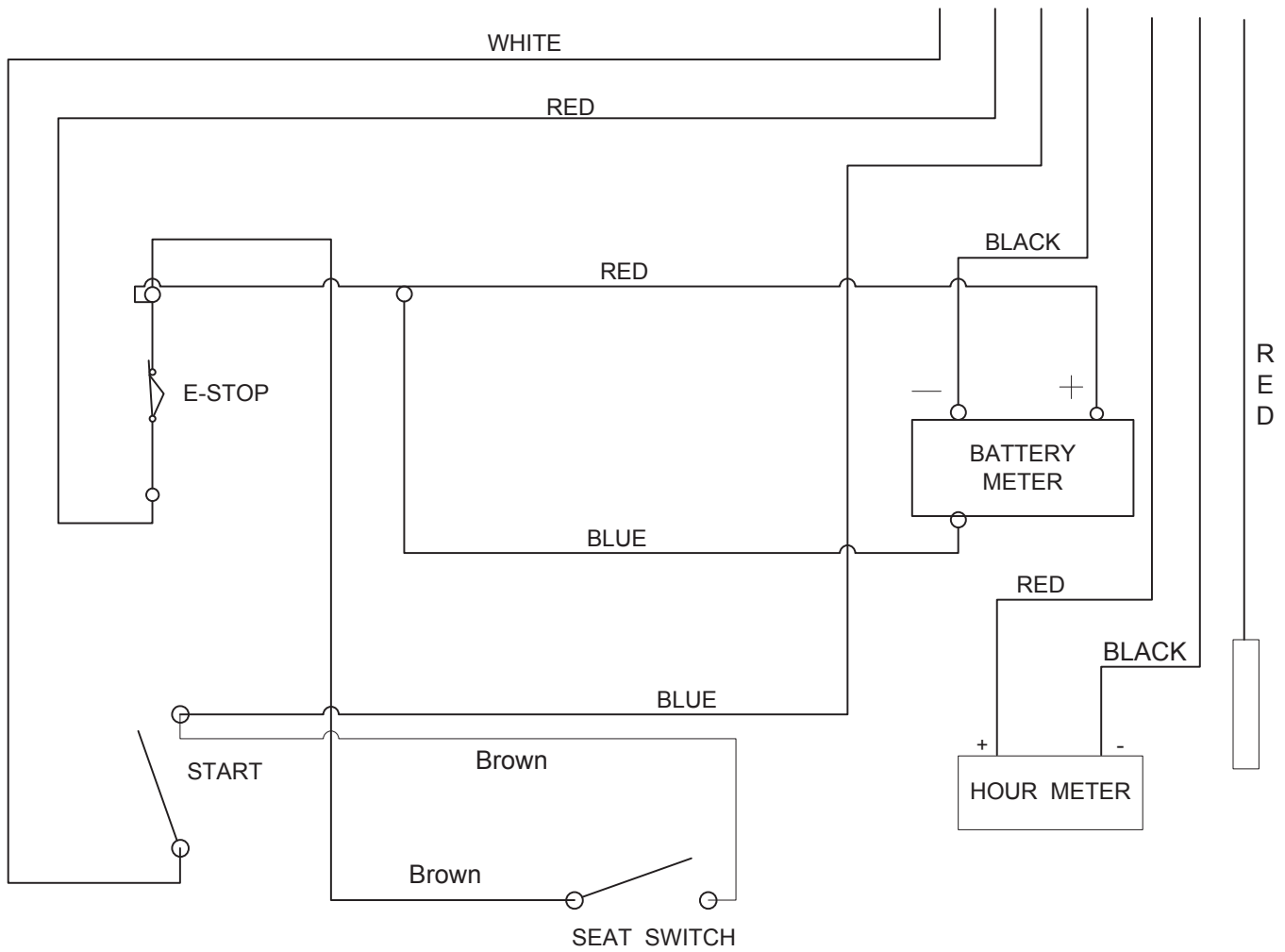

# Parts List and Diagrams

## 5700 MACHINE WIRING

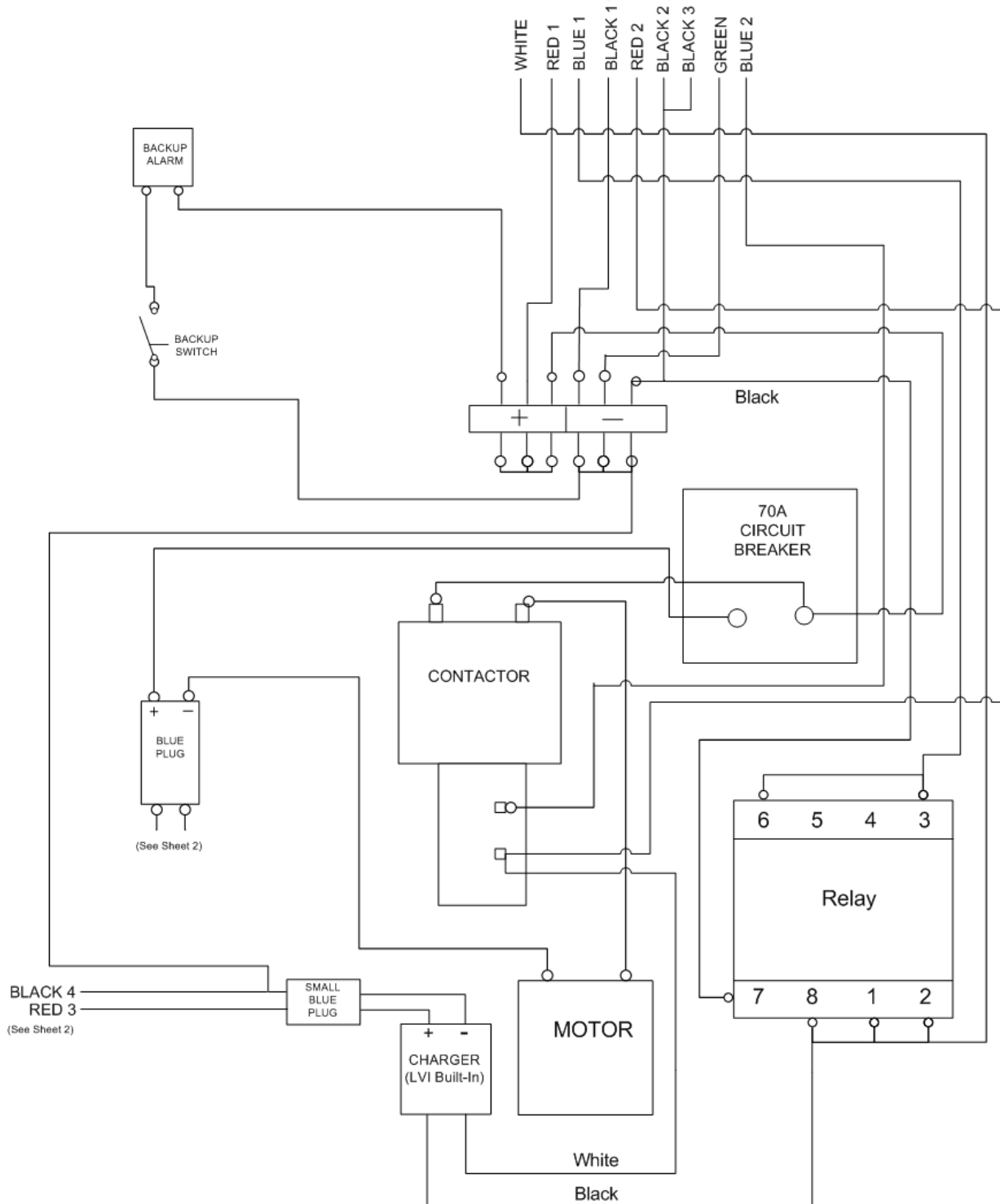

# Parts List and Diagrams

---

## TILE BOX



### Part 7074

The Tile Box works for wind rowing and assists for a fast clean-up and collection of tile debris for quick removal. High abrasion alloy for a long lasting edge. Resharpens just like a blade. 5" x 27" x 6" box. Attaches to the #7050-27 Cutting Head (required).

## FRONT WHEEL ASSEMBLY



### Part 5110-100

Allows stability and safe transportation over any surface. Easy and quick to attach.

5110-100W Replacement Wheel Only

## CUTTING HEAD EXTENSION



### Part 7050-15

Extension for cutting heads to reach under tight areas.

## OPTIONAL ARM RESTS



### Part 400321

Optional arm rests for added comfort. Set includes left and right arm rest and mounting hardware.

# Parts List and Diagrams

---

## Part 6701

Cutting head slide plate assembly is now available with hydraulic operation. Provides the operator the ability to adjust the height of the slide plate and allows precise angle adjustment of the cutting head with hydraulic hand control. No need to get off the machine, no lifting and no manual labor required to adjust the plate height. Adds 200 lbs of added weight to the front of the machine where it is most effective. Increases productivity by over 20%. Quick, simple and efficient hand control adjustments.

## HYDRAULIC SLIDE PLATE



# Material Safety Data Sheet (MSDS) Information

## VALVE REGULATED (VRLA) BATTERIES - ABSORBED ELECTROLYTE (AGM)

### PRODUCT IDENTIFICATION AND COMPANY IDENTIFICATION

Product Number(s): 5214-1, 5213-1, 5213-3

Chemical Family / Classification: Electric Storage Battery

Chemical / Trade Name (Identity used on label):

Date Revised: October 5th, 2010

Absorbed Electrolyte Battery/HGL,DC,HGHL Sealed Valve Regulated Lead-Acid Battery

Telephone: 86-20-84916671

Website: <http://www.fullriverdcbattery.com>

Manufacturer's Name: Fullriver Battery Manufacture Co. Ltd.

Address: P.O. Box 511475, Taishi Industrial Area, Yuwotou Town, Panyu Zone, Guangzhou, China

### HAZARDOUS INGREDIENTS / IDENTIFY INFORMATION

NOTE: Inorganic lead and electrolyte (water and sulfuric acid solution) are the primary components of every battery manufactured by Fullriver Technologies or its subsidiaries. Other ingredients may be present dependent upon battery type.

MATERIALS / COMPONENTS	% BY WT.	CAS NUMBER	EXPOSURE LIMITS		
			OSHA	ACGIH	NIOSH
Specific Chemical Identity / Common Name Inorganic Lead / Lead Compounds	65%-75%	7439-92-1	50 µg/m <sup>3</sup>	150 µg/m <sup>3</sup>	100 µg/m <sup>3</sup>
Specific Chemical Identity / Common Name Tin	< 0.5%	7440-31-5	2000 µg/m <sup>3</sup>	2000 µg/m <sup>3</sup>	N/A
Specific Chemical Identity / Common Name Calcium	< 0.2%	7440-70-2	N/A	N/A	N/A
Specific Chemical Identity / Common Name Sulfuric Acid (40%)/Battery Electrolyte (Acid)	16%-21%	7664-93-9	1 mg/m <sup>3</sup>	1 mg/m <sup>3</sup>	1 mg/m <sup>3</sup>
Specific Chemical Identity / Common Name Fiberglass Separator	5%	-	N/A	N/A	N/A
Specific Chemical Identity / Common Name Acrylonitrile Butadiene Styrene (ABS)	5%-10%	9003-56-9	N/A	N/A	N/A

### FIRE AND EXPLOSION HAZARD DATA

Fire and Explosive Properties:

Hydrogen Flash Point: N/A Hydrogen Auto Ignition Point: 580°C

Hydrogen Flammabl Limits in Air (% by Volume): LEL: 4.1 UEL: 74.2

Low Explosion Limit (LEL), Upper Explosion Limit (UEL)

Extinguishing Media:

Dry Chemical, Foam, CO2

Special Fire Fighting Hazards:

Use Positive Pressure, Self-Contained breathing apparatus.

Unusual Fire and Explosion Hazards:

If AGM batteries are properly charged they will not release any flammable hydrogen gas. If they are excessively overcharged the safety relief valve can open and release flammable hydrogen gas. They must always be assumed to contain this gas which, if ignited by burning cigarette, naked flame or spark, may cause battery explosion with dispersion of casing fragments and corrosive liquid electrolyte. Carefully follow manufacturer's instruction for installation and service. Keep away all sources of gas ignition and do not allow metallic articles to simultaneously contact the negative and positive terminals of a battery.



# Material Safety Data Sheet (MSDS) Information

---

## VALVE REGULATED (VRLA) BATTERIES - ABSORBED ELECTROLYTE (AGM)(CONT.)

### HEALTH HAZARD INFORMATION

#### ROUTES OF ENTRY

Sulfuric Acid: Harmful by all routes of entry.

Lead Compounds: Hazardous exposure can occur only when product is heated, oxidized or otherwise processed or damaged to create dust, vapor or fumes.

#### INHALATION

Sulfuric Acid: Breathing of sulfuric acid vapors or mists may cause severe respiratory irritation.

Lead Compounds: Inhalation of lead dust or fumes may cause irritation of upper respiratory tract and lungs.

Fiberglass Separator: Fiberglass is an irritant to the upper respiratory tract, skin and eyes. For exposure up to 10F°/use MSA Comfoll with type H filter. Above 10F° use Ultra Twin with type H filter. This product is not considered carcinogenic by NTP or OSHA.

#### INGESTION

Sulfuric Acid: May cause severe irritation of mouth, throat, esophagus and stomach.

Lead Compounds: Acute ingestion may cause abdominal pain, nausea, vomiting, diarrhea and severe cramping. This may lead rapidly to system toxicity and must be treated by a physician.

#### SKIN CONTACT

Sulfuric Acid: Severe irritation, burns and ulceration.

Lead Compounds: Not absorbed through the skin.

#### EYE CONTACT

Sulfuric Acid: Severe irritation, burns, cornea damage, and blindness.

Lead Compounds: May cause eye irritation.

#### EFFECTS OF OVEREXPOSURE - ACUTE

Sulfuric Acid: Severe skin irritation, damage to cornea, upper respiratory irritation.

Lead Compounds: Symptoms of toxicity include headache, fatigue, abdominal pain, loss of appetite, muscular aches and weakness, sleep disturbances and irritability.

#### EFFECTS OF OVEREXPOSURE - CHRONIC

Sulfuric Acid: Possible erosion of tooth enamel, inflammation of nose, throat and bronchial tubes. Lead Compounds: Anemia; neuropathy, particularly of the motor nerves, with wrist drop; kidney damage; reproductive changes in males and females.

#### CARCINOGENICITY

Sulfuric Acid: The International Agency for Research on Cancer (IARC) has classified "strong inorganic acid mist containing sulfuric acid" as a Category I carcinogen, a substance that is carcinogenic to humans. This classification does not apply to liquid forms of sulfuric acid or sulfuric acid solutions contained within a battery. Inorganic acid mist (sulfuric acid mist) is not generated under normal use of this product. Misuse of the product, such as overcharging, may result in the generation of sulfuric acid mist.

Lead Compounds: Lead is listed as a 2B carcinogen, likely in animals at extreme doses. Proof of carcinogenicity in humans is lacking at present.

#### MEDICAL CONDITIONS GENERALLY AGGRAVATED BY EXPOSURE

Overexposure to sulfuric acid mist may cause lung damage and aggravate pulmonary conditions. Contact of sulfuric acid with skin may aggravate diseases such as eczema and contact dermatitis. Lead and its compounds can aggravate some forms of kidney, liver and neurologic diseases.

# Material Safety Data Sheet (MSDS) Information

## VALVE REGULATED (VRLA) BATTERIES - ABSORBED ELECTROLYTE (AGM)(CONT.)

### EMERGENCY AND FIRST AID PROCEDURES

#### INHALATION

Sulfuric Acid: Remove to fresh air immediately. If breathing is difficult, give oxygen.

Lead Compounds: Remove from exposure, gargle, wash nose and lips; consult physician.

#### INGESTION

Sulfuric Acid: Give large quantities of water; do not induce vomiting; consult physician.

Lead Compounds: Consult physician immediately.

#### SKIN

Sulfuric Acid: Flush with large amounts of water for at least 15 minutes; remove contaminated clothing completely, including shoes.

Lead Compounds: Wash immediately with soap and water.

#### EYES

Sulfuric Acid and Lead: Flush immediately with large amounts of water for at least 15 minutes; consult physician.

### PRECAUTIONS FOR SAFE HANDLING AND USE

#### HANDLING AND STORAGE

Store batteries in cool, dry, well-ventilated areas with impervious surfaces and adequate containment in the event of spills. Batteries should also be stored under roof for protection against adverse weather conditions. Separate from incompatible materials. Store and handle only in areas with adequate water supply and spill control. Avoid damage to containers. Keep away from fire, sparks and heat.

#### PRECAUTIONARY LABELING

## POISON - CAUSES SEVERE BURNS DANGER - CONTAINS SULFURIC ACID

#### CHARGING

There is a possible risk of electric shock from charging equipment and from strings of series connected batteries, whether or not being charged. Shut-off power to chargers whenever not in use and before detachment of any circuit connections. If batteries are properly charged they will not release any flammable hydrogen gas. If they are excessively overcharged the safety relief valve can open and release flammable hydrogen gas. Charging space should be ventilated. Keep battery vent caps in position. Prohibit smoking and avoid creation of flames and sparks nearby. Wear face and eye protection when near batteries being charged.

#### SPILL OR LEAK PROCEDURES

Stop flow of material; contain/absorb small spills with dry sand, earth and vermiculite. Do not use combustible materials. If possible, carefully neutralize spilled electrolyte with soda ash, sodium bicarbonate, lime, etc. Wear acid-resistant clothing, boots, gloves, and face shield. Do not allow discharge of un-neutralized acid to sewer.

#### WASTE DISPOSAL METHOD

Spent batteries: Send to secondary lead smelter for recycling.

#### CONTROL MEASURES

Engineering Controls: Store and handle in well-ventilated area. If mechanical ventilation is used, components must be acid-resistant.

Work Practices: Handle batteries cautiously to avoid spills. Make certain vent caps are on securely. Avoid contact with internal components. Wear protective clothing when filling or handling batteries.

Respiratory Protection: None required under normal conditions. When concentrations of sulfuric acid mist are known to exceed the PEL, use NIOSH or MSHA-approved respiratory protection.

Protective Gloves: Rubber or plastic acid-resistant gloves with elbow-length gauntlet.

Eye Protection: Chemical goggles or face shield.

Other Protection: Acid-resistant apron. Under severe exposure emergency conditions, wear acid-resistant clothing and boots.

Emergency Flushing: In areas where sulfuric acid is handled in concentrations greater than 1%, emergency eyewash stations and showers should be provided, with unlimited water supply.

# Material Safety Data Sheet (MSDS) Information

## VALVE REGULATED (VRLA) BATTERIES - ABSORBED ELECTROLYTE (AGM)(cont.)

### PHYSICAL DATA

#### ELECTROLYTE:

Boiling Point:	203-240°F	Specific Gravity (H <sub>2</sub> O=1):	1.300-1.330
Melting Point:	N/A	Vapor Pressure (mm Hg):	10
Solubility in Water:	100%	Vapor Density (AIR = 1):	3.4
Evaporation Rate:	(Butyl Acetate = 1) Less than 1	% Volatile by Weight:	N/A
Appearance and Odor:	Manufactured article; no apparent odor. Electrolyte is a clear liquid with a sharp, penetrating, pungent odor.		

### REACTIVITY DATA

Stability: Stable

Conditions to Avoid: High temperature, Sparks and other sources of ignition

### INCOMPATIBILITY (MATERIALS TO AVOID)

**Electrolyte (Water and Sulfuric Acid Solution):** Contact with combustibles and organic materials may cause fire and explosion. Also reacts violently with strong reducing agents, metals, sulfuric trioxide gas, strong oxidizers, and water. Contact with metals may produce toxic sulfur dioxide fumes and may release flammable hydrogen gas.

**Lead Compounds:** Avoid contact with strong acids, bases, halides, halogenated, potassium nitrate, permanganate, peroxides, nascent hydrogen, and reducing agents.

### HAZARDOUS BYPRODUCTS

**Sulfuric Acid:** Sulfur trioxide, carbon monoxide, sulfuric acid mist, sulfur dioxide, and hydrogen. **Lead Compounds:** High temperatures likely to produce toxic metal fume, vapor, or dust; contact with strong acid or base or presence of nascent hydrogen may generate highly toxic arsine gas.

### ECOLOGICAL INFORMATION

Lead and its compounds can pose a threat if released into the environment.

### TRANSPORT INFORMATION

All Fullriver AGM batteries, when transported by air, surface or by vessel are identified as "Battery, Electric Storage, Wet, Nonspillable, Not Regulated".

The battery(s) must be identified as above on the Bill of Lading and properly packaged with their terminals protected from short circuit. NA or UN numbers do not apply.

Fullriver AGM battery(s) warning label identifies each battery as NONSPILLABLE.

Fullriver AGM battery(s) preprinted cartons identify each battery as NONSPILLABLE.

Fullriver AGM battery(s) shipped without Fullriver cartons (bulk packed) need to be identified as NONSPILLABLE or NONSPILLABLE BATTERY on the outer packaging.

**Air:** Fullriver AGM batteries meet the conditions in IATA/ICAO Special Provision A67.

**Surface:** Fullriver AGM batteries meet the conditions for DOT Haz Mat Regulations CFR-Tittle 49 parts 171-189.

**Vessel:** Fullriver Batteries meet the conditions of IMDG.

### REGULATORY INFORMATION

See 29 CFR 1910-268(b)(2)

### OTHER INFORMATION

The information herein is given in good faith, but no warranty, expressed or implied, is made.

# Material Safety Data Sheet (MSDS) Information

## CHEVRON HD 22 - 68 - HYDRAULIC FLUID

### PRODUCT IDENTIFICATION AND COMPANY IDENTIFICATION

Product Number(S): CPS221655, CPS221658, CPS221659  
Synonyms: Texaco Rando HD22, Texaco Rando HD 32, Texaco Rando HD 46, Texaco Rando HD 68

#### Company Information

Chevron Products Company  
a division of Chevron U.S.A. Inc.  
6001 Bollinger Canyon Road  
San Ramon, CA 94583  
United States of America  
www.chevronlubricants.com

Transportation Emergency Response

CHEMTREC: (800) 424-9300 or (703) 527-3887

Health Emergency

Chevron Emergency Information Center: Located in the USA.

International collect calls accepted.

(800) 231-0623 or (510) 231-0623

Product Information

email: lubemsds@chevron.com

Product Information: 800-LUBE-TEK

MSDS Requests: 800-414-6737

### HAZARDOUS INGREDIENTS / IDENTIFY INFORMATION

MATERIALS/COMPONENTS	CAS NUMER	AMOUNT
Highly Refined Mineral Oil (C15 - C50)	mixture	90-100% weight

### IMMEDIATE HEALTH EFFECTS

**Eye:** Not expected to cause prolonged or significant eye irritation.

**Skin:** Contact with the skin is not expected to cause prolonged or significant irritation. Not expected to be harmful to internal organs if absorbed through the skin. High-Pressure Equipment Information: Accidental high-velocity injection under the skin of materials of this type may result in serious injury. Seek medical attention at once should an accident like this occur. The initial wound at the injection site may not appear to be serious at first; but, if left untreated, could result in disfigurement or amputation of the affected part.

**Ingestion:** Not expected to be harmful if swallowed.

**Inhalation:** Not expected to be harmful if inhaled. Contains a petroleum-based mineral oil. May cause respiratory irritation or other pulmonary effects following prolonged or repeated inhalation of oil mist at airborne levels above the recommended mineral oil mist exposure limit. Symptoms of respiratory irritation may include coughing and difficulty breathing.

### FIRST AID MEASURES

**Eye:** No specific first aid measures are required. As a precaution, remove contact lenses, if worn, and flush eyes with water.

**Skin:** No specific first aid measures are required. As a precaution, remove clothing and shoes if contaminated. To remove the material from skin, use soap and water. Discard contaminated clothing and shoes or thoroughly clean before reuse.

**Ingestion:** No specific first aid measures are required. Do not induce vomiting. As a precaution, get medical advice.

**Inhalation:** No specific first aid measures are required. If exposed to excessive levels of material in the air, move the exposed person to fresh air. Get medical attention if coughing or respiratory discomfort occurs.

**Note to Physicians:** In an accident involving high-pressure equipment, this product may be injected under the skin. Such an accident may result in a small, sometimes bloodless, puncture wound. However, because of its driving force, material injected into a fingertip can be deposited into the palm of the hand. Within 24 hours, there is usually a great deal of swelling, discoloration, and intense throbbing pain. Immediate treatment at a surgical emergency center is recommended.

### FIRE FIGHTING MEASURES

Leaks/ruptures in high pressure system using materials of this type can create a fire hazard when in the vicinity of ignition sources (eg. open flame, pilot lights, sparks, or electric arcs).

**FIRE CLASSIFICATION:** OSHA Classification (29 CFR 1910.1200): Not classified by OSHA as flammable or combustible.

**NFPA RATINGS:** Health: 0 Flammability: 1 Reactivity: 0

### FLAMMABLE PROPERTIES:

Flashpoint: (Cleveland Open Cup) 150 C (302 F) (Min)

Autoignition: No Data Available

Flammability (Explosive) Limits (% by volume in the air): Lower: Not Applicable Upper: Not Applicable

# Material Safety Data Sheet (MSDS) Information

## CHEVRON HD 22 - 68 - HYDRAULIC FLUID (CONTINUED)

**EXTINGUISHING MEDIA:** Use water fog, foam, dry chemical or carbon dioxide (CO<sub>2</sub>) to extinguish flames.

**PROTECTION OF FIRE FIGHTERS:** Fire Fighting instructions: This material will burn although it is not easily ignited. For fires involving this material, do not enter any enclosed or confined fire space without proper protective equipment, including self-contained breathing apparatus.

**Combustion Products:** Highly dependent on combustion conditions. A complex mixture of airborne solids, liquids, and gases including carbon monoxide, carbon dioxide, and unidentified organic compounds will be evolved when pounds will be evolved when this material undergoes combustion.

### ACCIDENTAL RELEASE MEASURES

**Protective Measures:** Eliminate all sources of ignition in vicinity of spilled material.

**Spill Management:** Stop the source of the release if you can do it without risk. Contain release to prevent further contamination of soil, surface water or groundwater. Clean up spill as soon as possible, observing precautions in Exposure Controls/Personal Protection. Use appropriate techniques such as applying non-combustible absorbent materials or pumping. Where feasible and appropriate, remove contaminated soil. Place contaminated materials in disposable containers and dispose of in a manner consistent with applicable regulations.

**Reporting:** Report spills to local authorities and/or the U.S. Coast Guard's National Response Center at (800) 424-8802 as appropriate or required.

### HANDLING AND STORAGE

**Precautionary Measures:** DO NOT USE IN HIGH PRESSURE SYSTEMS in the vicinity of flames, sparks and hot surfaces. Use only in well ventilated areas. Keep container closed.

**General Handling Information:** Avoid contaminating soil or releasing this material into sewage and drainage systems and bodies of water.

Electrostatic charge may accumulate and create a hazardous condition when handling this material. To minimize this hazard, bonding and grounding may be a necessary but may not, by themselves, be sufficient. Review all operations which have the potential of generating and accumulating an electrostatic charge and/or a flammable atmosphere (including tank and container filling, splash filling, tank cleaning, sampling, gauging, switch loading, filtering, mixing, agitation, and vacuum truck operations) and use appropriate mitigating procedures. For more information, refer to OSHA standard 29 CFR 1910.106, 'Flammable and Combustible Liquids', National Fire Protection Association (NFPA 77, 'Recommended Practice on Static Electricity', and/or the American Petroleum Institute (API) Recommended Practice 2003, 'Protection Against Ignitions Arising Out of Static, Lightning, and Stray Currents'.

**Container Warnings:** Container is not designed to contain pressure. Do not use pressure to empty container or it may rupture with explosive force. Empty containers retain product residue (solid, liquid, and/or vapor) and can be dangerous. Do not pressurize, cut, weld, braze, solder, drill, grind, or expose such containers to heat, flame, sparks, static electricity, or other sources of ignition. They may explode and cause injury or death. Empty containers should be completely drained, properly closed, and promptly returned to a drum reconditioner or disposed of properly.

### EXPOSURE CONTROLS/PERSONAL PROTECTION

**GENERAL CONSIDERATIONS:** Consider the potential hazards of this material (see Section 3), applicable exposure limits, job activities, and other substances in the workplace when designing engineering controls and selecting personal protective equipment. If engineering controls or work practices are not adequate to prevent exposure to harmful levels of this material, the personal protective equipment listed below is recommended. The user should read and understand all instructions and limitations supplied with the equipment since protection is usually provided for a limited time or under certain circumstances.

**ENGINEERING CONTROLS:** Use in a well-ventilated area.

### PERSONAL PROTECTIVE EQUIPMENT

**Eye/Face Protection:** No special eye protection is normally required. Where splashing is possible, wear safety glasses with side shields as a good safety practice.

**Skin Protection:** No special protective clothing is normally required. Where splashing is possible, select protective clothing depending on operations conducted, physical requirements and other substances in the workplace. Suggested materials for protective gloves include: 4H (PE/EVAL), Nitrile Rubber, Silver Shield, Viton.

**Respiratory Protection:** No respiratory protection is normally required. If user operations generate an oil mist, determine if airborne concentrations are below the occupational exposure limit for mineral oil mist. If not, wear an approved respirator that provides adequate protection from measured concentrations of this material. For air-purifying respirators use a particulate cartridge. Use a positive pressure air-supplying respirator in circumstances where air-purifying respirators may not provide adequate protection.

# Chevron HD 22 - 68 - hydraulic fluid (continued)

## CHEVRON HD 22 - 68 - HYDRAULIC FLUID (CONTINUED)

### PHYSICAL AND CHEMICAL PROPERTIES

Attention: The data below are typical values and do not constitute a specification.

Color: Yellow	Physical State: Liquid	Odor: Petroleum odor
pH: Not applicable	Vapor Pressure: <0.01 mmHg @ 37.8 C (100 F)	Vapor Density (Air = 1): >1
Boiling Point: >315.6 C (600 F)	Solubility: Soluble in hydrocarbons; insoluble in water	Freezing Point: Not Applicable
Melting Point: Not Applicable	Specific Gravity: 0.86 - 0.87 @ 15.6 C (60.1 F) / 15.6 (60.1F)	Density: 0.86 kg/l - 0.9 kg/l @ 15 C (59 F)
Viscosity: 22 cSt - 61.2 cSt @40 C (104 F) (Min)		

### STABILITY AND REACTIVITY

**Chemical Stability:** This material is considered stable under normal ambient and anticipated storage and handling conditions of temperature and pressure.

**Incompatibility With Other Materials:** May react with strong acids or strong oxidizing agents, such as chlorates, nitrates, peroxides, etc.

**Hazardous Decomposition Products:** None known. (None expected)

**Hazardous Polymerization:** Hazardous polymerization will not occur.

### TOXICOLOGICAL INFORMATION

#### IMMEDIATE HEALTH EFFECTS

**Eye Irritation:** The eye irritation hazard is based on evaluation of data for similar materials or product components.

**Skin Irritation:** The skin irritation hazard is based on evaluation of data for similar materials or product components.

**Skin Sensitization:** No product toxicology data available.

**Acute Dermal Toxicity:** The acute dermal toxicity hazard is based on evaluation of data for similar materials or product components.

**Acute Oral Toxicity:** The acute oral toxicity hazard is based on evaluation of data for similar materials or product components.

**Acute Inhalation Toxicity:** The acute inhalation toxicity hazard is based on evaluation of data for similar materials or product components.

#### ADDITIONAL TOXICOLOGY INFORMATION

This product contains petroleum base oils which may be refined by various processes including severe solvent extraction, severe hydrocracking, or severe hydrotreating. None of the oils requires a cancer warning under the OSHA Hazard Communication Standard (29 CFR 1910.1200). These oils have not been listed in the National Toxicology Program (NTP) Annual Report nor have been classified by the International Agency for Research on Cancer (IARC) as; carcinogenic to humans (Group 1), probably carcinogenic to humans (Group 2), or possibly carcinogenic to humans (Group 2B). These oils have not been classified by the American Conference of Governmental Industrial Hygienists (ACGIH) as: confirmed human carcinogen (A1), suspected human carcinogen (A2), or confirmed animal carcinogen with unknown relevance (A3).

### ECOLOGICAL INFORMATION

#### ECOTOXICITY

This material is not expected to be harmful to aquatic organisms. The ecotoxicity hazard is based on an evaluation of data for the components of a similar material.

#### ENVIRONMENTAL FATE

This material is not expected to be readily biodegradable.

#### DISPOSAL CONSIDERATIONS

Use material for its intended purpose or recycle if possible. Oil collection services are available for used oil recycling or disposal. Place contaminated materials in containers and dispose of in a manner consistent with applicable regulations. Contact your sales representative or local environmental or health authorities for approved disposal or recycling methods.

#### TRANSPORT INFORMATION

The description shown may not apply to all shipping situations. Consult 49CFR, or appropriate Dangerous Goods Regulations, for additional description requirements (e.g., technical name) and mode-specific or quantity-specific shipping requirements.

**DOT Shipping Description:** PETROLEUM LUBRICATING OIL, NOT REGULATED AS A HAZARDOUS MATERIAL FOR TRANSPORTATION UNDER 49 CFR Additional Information: NOT HAZARDOUS BY U.S. DOT. ADR/RID HAZARD CLASS NOT APPLICABLE

**IMO/IMDG Shipping Description:** PETROLEUM LUBRICATING OIL; NOT REGULATED AS DANGEROUS GOODS FOR TRANSPORT UNDER THE IMDG CODE

**ICAO/IATA Shipping Description:** PETROLEUM LUBRICATING OIL; NOT REGULATED AS DANGEROUS GOODS FOR TRANSPORT UNDER ICAO

# Chevron HD 22 - 68 - hydraulic fluid (continued)

## REGULATORY INFORMATION

### EPCRA 311/312 CATEGORIES:

1. Immediate (Acute) Health Effects: NO
2. Delayed (Chronic) Health Effects: NO
3. Fire Hazard: NO
4. Sudden Release of Pressure Hazard: NO
5. Reactivity Hazard: NO

### REGULATORY LISTS SEARCHED:

- |                     |                      |
|---------------------|----------------------|
| 01-1=IARC Group1    | 03=EPCRA 313         |
| 01-2A=IARC Group 2A | 04=CA Proposition 65 |
| 01-2B=IARC Group 2  | 05=MA RTK            |
| 02=NTP Carcinogen   | 06=NJ RTK            |

No components of this material were found on the regulatory lists above.

### CHEMICAL INVENTORIES:

All components comply with the following chemical inventory requirements: AICS (Australia), DSL (Canada), ENCS (Japan), IECSC (China), KECI (Korea), PICCS (Philippines), TSCA (United States)

One or more components is listed on ELINCS (European Union). Secondary notification by the importer may be required.

### NEW JERSEY RTK CLASSIFICATION:

Under the New Jersey Right-to-Know Act L. 1983 Chapter 315 N.J.S.A. 34:5A-1 et. seq., the product is to be identified as follows: PETROLEUM OIL (Hydraulic oil)

### WHMIS CLASSIFICATION:

This product is not considered a controlled product according to the criteria of the Canadian Controlled Products Regulations.

### OTHER INFORMATION

NFPA RATINGS: Health: 0 Flammability: 1 Reactivity: 0

HMIS RATINGS: Health: 1 Flammability: 1 Reactivity: 0

(0-Least, 1-Slight, 2-Moderate, 3-High, 4-Extreme, PPE:- Personal Protection Equipment Index recommendation,\*-Chronic Effect Indicator). These values are obtained using the guidelines or published evaluations prepared by the National Fire Protection Association (NFPA) or the National Paint and Coating Association (for HMIS ratings).

LABEL RECOMMENDATION: Label Category: INDUSTRIAL OIL 1 - IND1

REVISION STATEMENT: This revision updates the following sections of this Material Safety Data Sheet:

Revision Date: January 15, 2007

### ABBREVIATIONS THAT MAY HAVE BEEN USED IN THIS DOCUMENT:

- |   |  |
|---|--|
| TLV - Threshold Limit Value                                     | TWA - Time weighted Average                        |
| STEL - Short-term Exposure Limit                                | PEL - Permissible Exposure Limit                   |
| CAS - Chemical Abstract Service Number                          | IMDG - International Maritime Dangerous Goods Code |
| API - American Petroleum Institute                              | MSDS - Material Safety Data Sheet                  |
| ACGIH - American Conference of Government Industrial Hygienists | CVX - Chevron                                      |
| NFPA - National Fire Protection Association (USA)               | DOT - Department of Transportation                 |
| NTP - National Toxicology Program(USA)                          | IARC - International Agency for Research on Cancer |
| OSHA - Occupational Safety and Health Administration            |  |

Prepared according to the OSHA Hazard Communication Standard (29 CFR 1910.1200) and the ANSI MSDS Standard (Z400.1) by the Chevron Energy Technology Company, 100 Chevron Way, Richmond, California 94802.

The above information is based on the data of which we are aware and is believed to be correct as of the date hereof. Since this information may be applied under conditions beyond our control and with which we may be unfamiliar and since data made available subsequent to the date hereof may suggest modifications of the information, we do not assume any responsibility for the results of its use. This information is furnished upon condition that the person receiving it shall make his own determination of the suitability of the material for his particular purpose.





# Guarantee

---

National Flooring Equipment, Inc. (National) warrants to the first consumer/purchaser that this National brand product (5700 Ride-on Floor Scraper) when shipped in its original container, will be free from defective workmanship and materials and agrees that it will, at its option, either repair the defect or replace the defective product or part thereof at no charge to the purchaser for parts or labor for the period(s) set forth below.

This warranty does not apply to any appearance items of the product, to the additional excluded items set forth below, or to any product, the exterior of which has been damaged or defaced, which has been subjected to misuse, abnormal service or handling, or which has been altered or modified in design or construction.

In order to enforce the rights under this limited warranty, the purchaser should follow the steps set forth below and provide proof of purchase to National.

The limited warranty described herein is in addition to whatever implied warranties may be granted to purchasers by law. All implied warranties including the warranties of merchantability and fitness for use are limited to the periods from the date of purchase as set forth below. Some states do not allow time limitations on an implied warranty, so the above limitation may not apply to you.

Neither the sales person of the seller, nor any other person, is authorized to make any other warranties other than those described herein, or to extend the duration of any warranties beyond the time period described herein on behalf of National.

The warranties described herein shall be the sole and exclusive warranties granted by National and shall be the sole and exclusive remedy available to the purchaser. Correction of defects in the manner and for the period of time described herein, shall constitute complete fulfillment of all liabilities and responsibilities of National to the purchaser with respect to the product and shall constitute full satisfaction of all claims, whether based on contract, negligence, strict liability or otherwise. In no event shall National be liable, or in any way responsible for any damage or defects in the product which were caused by repairs or attempted repairs performed by anyone other than National. Nor shall National be liable, or in any way responsible, for any incidental or consequential, economics or property damage. Some states do not allow the exclusion of incidental or consequential damages, so the above exclusion may not apply to you.

This warranty gives you specific legal rights. You may also have other rights which vary from state to state.

## WARRANTY PERIOD

The 5700 Ride-on Floor Scraper is guaranteed to be free of manufacturer defective workmanship and in quality of materials for a period of one year.

Items excluded from warranty coverage, unless found and reported defective immediately upon removal from the original shipping container and before being used by the original purchaser.

A freight damage claim must be filed with the carrier by the purchaser, the shipper cannot file the freight claim.

**TO OBTAIN SERVICE CONTACT NATIONAL FLOORING EQUIPMENT, INC. TOLL FREE AT 800-245-0267 FOR A REPAIR AUTHORIZATION NUMBER. COD FREIGHT RETURNS WILL NOT BE ACCEPTED. FREIGHT COLLECT SHIPMENTS WILL NOT BE ACCEPTED. WARRANTY REPAIRS MUST BE ACCOMPANIED BY DATE OF PURCHASE RECEIPT AND A RETURN/REPAIR AUTHORIZATION NUMBER.**

**RETURN/REPAIR AUTHORIZATION NUMBER:** \_\_\_\_\_

**MACHINE SERIAL NUMBER:** \_\_\_\_\_



Made in America Since 1968

9250 Xylon Avenue N • Minneapolis, MN 55445 • U.S.A.  
Toll-free 800-245-0267 • Phone 763-315-5300 • Fax 800-648-7124 • Fax 763-535-8255  
Web Site: [www.nationalequipment.com](http://www.nationalequipment.com) • E-Mail: [info@nationalequipment.com](mailto:info@nationalequipment.com)