

#2900HS PANTHER[®] HIGH SPEED FLOOR PREP SYSTEM INSTRUCTION MANUAL



Read Manual Before Operating Machine



National
Flooring Equipment, Inc.



9250 XYLON AVENUE NORTH • MINNEAPOLIS, MN 55445 • U.S.A.
800-245-0267 • 763-535-8206 • FAX 763-535-8255 • FAX 800-648-7124
WEB SITE: www.nationalequipment.com • E-MAIL: info@nationalequipment.com

2900HS TABLE OF CONTENTS

■ Table of Contents	2-5
■ Hydraulic Safe Operation	6-7
A. Maintaining A Safe Work Environment	6
B. Pressure.....	6-7
C. Flammability	7
D. Hydraulic Fluid.....	7
■ Rules for Safe Operation.....	8-10
A. Safety Precautions/General Rules.....	8-9
B. Characteristics of a Defensive Operator	10
■ Safety Instructions	11
■ Battery Operation	12
■ Battery Safe Operation	13-15
A. First Aid	13
B. Ventilation	13
C. Grounding & A/C Power Connection Instruction	13
D. Installation	14
E. Cooling Time	14
F. Battery General Information	14
H. Battery Freezing	14
I. Shipping.....	14
J. Battery Warranty	14
K. Battery Operation	15
■ Machine Charging Instructions	16
■ On Board Charger - Manufacturers Manual	16.1-16.4
■ Commonly Asked Questions - Battery Operation.....	17
■ Features/Specifications	18-19
A. Vibration/Sound Data	19
■ Operating Controls	20-21
A. Power On/Off Switch	20
B. Hydraulic Levers	20
C. Emergency Stop Switch	21
D. Seat Switch	21
E. To Store Machine	21
F. Cylinder Lift	21
■ Operational Tips	22
A. Caster	22
B. Foot Peg	22
C. Seat.....	22

2900HS TABLE OF CONTENTS

D. Disarm Machine	22
E. Turn Machine Off.....	22
F. Leakage	22
G. Angle of the Head is Set Steep	22
H. Raising or Lowering the Slide Plate	22
■ Loading/Unloading	23-24
A. Dock Heights	23
B. Power-Gate	23
C. Ramps	23
D. Forklift Cups	24
E. Winches	24
F. Transporting	24
G. Wheel Chocks	24
■ Center of Gravity	25
■ Job Site Movement	26-27
A. Taping Wheels.....	26
B. Leap Frogging Boards.....	26
C. Palletizing	26
D. Front Wheel Assembly	26
E. To Move Machine Without Power	27
F. Moving Machine on Caster	27
■ Wheel Sizes	28
A. Wheel Size	28
■ Cutting Head and Blade	29-31
A. Dialing in the Machine.....	29
B. Saving Time with Extra Cutting Heads	29
C. Adjusting Slide Plate and Cutting Head	29
D. Shear Point	29
E. Weight vs. Sharpness	30
F. Cutting Head Angle	30
G. Steep Cutting Head Angle.....	30
H. Swivel Head	30
I. Saving Time with Extra Cutting Heads	30
J. Cutting Head Insertion	31
K. Shank Blade Insertion	31
L. Blade Setting.....	31
M. Self-Scoring Blades.....	31
N. Blade Insertion or Blade Changing	31

2900HS TABLE OF CONTENTS

■ Blade Application/Set-Up	32-34
A. Ceramic Set-Up.....	32
B. Wood Set-Up.....	32
C. Secondary Backing Carpet Set-Up	32
D. Foam Back Carpet Set-Up	32
E. Double Stick Carpet Set-Up	32
F. VCT Tile Set-Up	32
G. Rubber Tile Set-Up	32
H. Re-Scraping Set-Up	33
I. Thin Coating Set-Up	33
J. Working Over Concrete.....	33
K. Working Over Wood	33
L. Working Over Soft Sub-Floor	33
M. Cross Room Ditching	34
N. Checker Board Ditching	34
■ Blades	35-38
A. Types of Blades.....	35
B. Blade Sharpening	36
C. Self-Scoring Blade Sharpening.....	36
D. Carbide Tipped Blade Sharpening	36
E. Blade Selection Chart	37-38
■ Machine Maintenance	39-44
A. Slide Plate Removal	39
B. Raising or Lowering the Slide Plate	39
C. Lower Cutting Head Support.....	39
D. Leak Maintenance.....	39
E. Oil Level & Oil Change Out.....	40
F. Wheel Motor Change Out	40
G. Hose Change Out	41
H. Foot Peg	41
I. Pump Change Out	41
J. Valve Change Out.....	41
K. Motor Change Out.....	41
L. Hydraulic Cylinder Change Out.....	42
M. Wheel Changing	42
N. Changing Filter	42

2900HS TABLE OF CONTENTS

O. Caster Maintenance	43
P. Seat Replacement.....	44
Q. Switches	44
R. Debris Deflector Mounting Instructions	44
■ Complete Parts List	45-50
■ Part Numbers and Diagrams	51-67
A. External Parts	51
B. Hood & External Parts.....	52
C. Beeper & Hood Parts	53
D. Electric Box & Battery Connector Parts.....	54
E. Motor & Fuse Parts	55
F. Gear Pump Parts.....	56
G. Wheel Parts.....	57
H. Control Lever Parts	58
I. Spool & Hose Parts	59
K. Filter & Tank Parts	60
L. Cylinder Parts.....	61
M. Slide Plate/Deflector, Caster & Foot Peg Parts	62
N. Batteries, Weights & Charger Parts	63
■ Labels.....	64-66
■ Accessories	67
■ Blades & Cutting Heads	68-69
■ Wiring Diagrams.....	70-72
■ Material Safety Data.....	73-78
■ Battery Material Safety Data	79-80
■ Guarantee	81
■ Return Sheet	82
■ Blade Order Form	83-84

2900HS HYDRAULIC SAFE OPERATION

MAINTAINING A SAFE WORK ENVIRONMENT

Establishing a safe working environment in and around your hydraulic equipment is just common sense. The easiest and most effective way to avoid problems is to make sure associates understand their equipment, know how to operate it safely and recognize the danger it represents if handled carelessly. A few things you must be aware of include:

1. **PRESSURE:** Hydraulic fluid under pressure is dangerous and can cause serious injury.
2. **FLAMMABILITY:** When ignited, some hydraulic fluids can explode and/or cause fires.
3. **MECHANICAL:** Hydraulic fluid creates movement, which causes parts of your equipment to move or rotate. Always be aware of what you are doing.
4. **MOISTURE:** Use caution when operating in wet or high moisture conditions. Make sure all electrical fittings, switches, cords plus strain reliefs are in good condition. Always unplug when not in use and when doing any service work.
5. **ELECTRICAL:** Faulty wiring can also be an electrical hazard. A regular preventive maintenance program should always include a wiring check. Unplug batteries and/or charger before servicing.
6. **TEMPERATURE:** Because this machine operates at a relatively low pressure, overheating is not common. If surface of tank becomes too hot to touch by hand (above 130°), shut off machine and allow to cool off.

PRESSURE

Our system runs at or below 2,000 psi. Never look for a leak when unit is under pressure. Using your hand could cause serious injury. A few common ways to encounter hydraulic fluid under pressure include:

1. **PINHOLE:** Fluid under pressure can cause serious injury. It can be almost invisible escaping from a pinhole, and it can pierce the skin into the body. Do not touch a pressurized hydraulic hose assembly with any part of your body. If fluid punctures the skin, even if no pain is felt, a serious emergency exists. Obtain medical assistance immediately. Failure to do so can result in loss of the injured part or death.
2. **LEAK:** Keep fittings and hoses tight. Only check and service when not under pressure. Leaking hydraulic fluid is not only unsightly, it's hazardous. In addition to making workplace floors slippery and dangerous, leaks also contaminate the environment. Before cleaning an oil spill, always check EPA, state and local regulations.

LEAK AT THREAD END/SEAT

Problem: Coupling leaks at thread or seat. This may be caused by any of the following:

- a. Missing or damaged O-rings.
- b. Damaged threads or seat angle.
- c. Thread alignment.
- d. Incompatible thread ends or seat angles.
- e. Over or under torquing.

Solution: Remove the connection and inspect.

1. Certain couplings require the use of an O-ring. If it is missing, replace it. If an O-ring is used, check for damage caused by installation or possible material breakdown from heat or fluid incompatibility. Alternative O-ring materials may be required. Replace if necessary.
2. Check the threads and/or seat angle for damage that may have occurred prior to or during installation. Any ding or burr may be a potential leak path. Replace if necessary.

2900HS HYDRAULIC SAFE OPERATION

PRESSURE (continued)

3. If the coupling was misaligned during installation, threads may have been damaged. Replace and carefully install.
4. Over torquing of a threaded connection can stretch and damage threads and mating seat angles. Over torquing can also damage the staking area of the nut. Under torquing does not allow proper sealing.

⚠ CAUTION: Never check for leaks over hose or hydraulic connections. Instead, use a piece of cardboard to locate a pressurized leak. For drips (low pressure leaks), use a rag to clean the area and determine where the leak originates.

⚠ CAUTION: Never touch a pressurized hose assembly. Shut down the hydraulic system before checking hose temperature.

3. **BURST:** Whether due to improper selection or damage, a ruptured hose can cause injury. If it bursts, a worker can be burned, cut, injected or may slip and fall.
4. **COUPLING BLOW-OFF:** If the assembly is not properly made or installed, the coupling could come off and hit or spray a worker, possibly resulting in serious injury. Never operate machine without guards.

FLAMMABILITY

With the exception of those comprised primarily of water, all hydraulic fluid is flammable when exposed to the proper conditions (including many “fire-resistant” hydraulic fluids).

Leaking pressurized hydraulic fluids may develop a mist or fine spray that can flash or explode upon contact with a cause of ignition. These explosions can be very severe and could result in serious injury or death.

Precautions should be taken to eliminate all ignition sources from contact with escaping fluids, sprays or mists resulting from hydraulic failures. Sources of ignition could be electrical discharges (sparks), open flames, extremely high temperatures, sparks caused by metal-to-metal contact, etc.

HYDRAULIC FLUID

Only use Texaco Rando 46 Hydraulic Oil or Compatible Fluid like IS032. Non-compatible fluids could cause damage to unit or serious injury.

⚠ WARNING: When using electric tools, always follow basic safety precautions to reduce the risk of electric shock and personal injury.

2900HS RULES FOR SAFE OPERATION



READ AND SAVE ALL INSTRUCTIONS FOR FUTURE USE. Before use, be sure everyone operating this equipment reads and understands this manual as well as any labels packaged with or attached to the machine and components and view the instruction video. Extra copies of the manual and video are available.

- 1. KNOW YOUR EQUIPMENT:** Read this manual and view instruction video carefully to learn equipment applications and limitations as well as potential hazards associated with this type of equipment.

⚠ WARNING: Disarm machine when not in use. Remove Cutting Head or lower Cutting Head to the floor. When exiting machine (getting off machine), remove lower Cutting Head to the floor. When transporting machine around job site, remove Cutting Head. Failure to follow these instructions could cause severe bodily injury.

- 2. DISARM MACHINE:** Remove cutting head or drop cutting head to the floor when machine is not in use.
- 3. DO NOT "SIDE HILL" MACHINE:** See Page 23.
- 4. DISCONNECT CHARGER'S:** Disconnect machine from charger's before operating machine.
- 5. AVOID DANGEROUS ENVIRONMENTS:** Do not use in rain, damp or wet locations, or in the presence of explosive atmospheres (gaseous fumes, dust or flammable materials). Remove materials or debris that may be ignited by sparks.
- 6. KEEP WORK AREA CLEAN AND WELL LIT:** Cluttered, dark work areas invite accidents.
- 7. DRESS PROPERLY:** Do not wear loose clothing. These may be caught in moving parts. Keep hands and gloves away from moving parts.
- 8. USE SAFETY EQUIPMENT:** Everyone in the work area should wear safety goggles or glasses complying with current safety standards. Wear hearing protection during extended use and a dust mask for dusty operations. Hard hats, face shields, safety shoes, etc. should be worn when specified or necessary.
- 9. KEEP BYSTANDERS AWAY:** Children and bystanders should be kept at a safe distance from the work area to avoid distracting the operator. Operator should be aware of who is around them and their proximity.
- 10. PROTECT OTHERS IN THE WORK AREA:** Provide barriers or shields as needed to protect others from debris and machine operation.
- 11. USE PROPER ACCESSORIES:** Using accessories that are not recommended may be hazardous. Be sure accessories are properly installed and maintained. Do not delete a guard or other safety device when installing an accessory, attachment or servicing.
- 12. CHECK FOR DAMAGED PARTS:** Inspect guards and other parts before use. Check for misalignment, binding of moving parts, improper mounting, broken parts and any other conditions that may affect operation. If abnormal noise or vibration occurs, turn the tool off immediately and have the problem corrected before further use. Do not use damaged equipment. Tag damaged machine "DO NOT USE" until repaired. A guard or other damaged parts should be properly repaired or replaced. For all repairs, insist on only identical National replacement parts.
- 13. REMOVE ALL ADJUSTING KEYS AND WRENCHES:** Make a habit of checking that the adjusting keys, wrenches, etc. are removed from the tool before turning it on.

2900HS RULES FOR SAFE OPERATION

14. **GUARD AGAINST ELECTRIC SHOCK:** Prevent body contact with grounded surfaces such as pipes, battery plug connection, radiators, ranges and refrigerators. When scoring or making cuts, always check the work area for hidden wires or pipes to reduce shock hazards.
15. **AVOID ACCIDENTAL STARTING:** Be sure equipment is turned off before plugging it in. Do not use if the power switch does not turn the machine on and off properly.
16. **DO NOT FORCE EQUIPMENT:** Equipment will perform best at the rate for which it was designed. Excessive force only causes operator fatigue, increased wear and reduced control.
17. **KEEP HANDS AND FEET AWAY FROM ALL CUTTING EDGES AND MOVING PARTS.**
18. **WEAR GLOVES WHEN CHANGING BLADES.**
19. **DO NOT ABUSE CORD:** Never unplug the battery charger by yanking the cord from the outlet or from the battery. Pull plug rather than cord to reduce the risk of damage. Keep the cord away from heat, oil, sharp objects, cutting edges and moving parts.
20. **DO NOT OVERREACH. MAINTAIN CONTROL:** Stay properly seated. Keep proper footing and balance at all times. Maintain a firm grip.
21. **STAY ALERT:** Watch what you are doing, and use common sense. Do not use when you are tired, distracted or under the influence of drugs, alcohol or any medication causing decreased control.
22. **STARTING MACHINE:** On/off switch must be in off position before connecting to power source.
23. **UNPLUG EQUIPMENT:** Disconnect battery and/or charger's before servicing or when not operating.
24. **MAINTAIN EQUIPMENT CAREFULLY:** Keep control levers dry, clean and free from oil and grease. Keep cutting edges sharp and clean. Follow instructions for lubricating and changing accessories. Periodically inspect battery, charger's and all plug connections. Have damaged parts repaired or replaced.
25. **STORE IDLE EQUIPMENT:** When not in use, store in a dry, secured place. Keep away from children. Remove blade or keep blade lowered to the floor (disarm machine).
26. **MAINTAIN LABELS AND NAME PLATES:** These carry important information. If unreadable or missing, contact National for a free replacement.
27. **MACHINE IS HEAVY, DO NOT DROP:** Counter weights are heavy. Take caution when removing or reassembling. Take caution when moving or transporting. Do not drop batteries.
28. **BATTERIES:** Only replace batteries by the manufacturer or its servicing agent. Do not open or tamper with Batteries. Doing so voids all warranties and could cause injury due to electric shock.
29. **COMMERCIAL APPLICATION:** Machine is intended for commercial use only.

 **WARNING:** Exposure to dust may cause respiratory ailments. Use approved NIOSH or OSHA respirators, safety glasses or face shields, gloves and protective clothing. Provide adequate ventilation to eliminate dust, or to maintain dust level below the Threshold Limit Value for nuisance dust as classified by OSHA.

2900HS RULES FOR SAFE OPERATION

CHARACTERISTICS OF A DEFENSIVE OPERATOR

- Education
- Alert
- Skills
- Judgment
- Common Sense
- Recognizes the Hazards
- Understands the Defense
- Acts Correctly

A GOOD OPERATOR IS A “DEFENSIVE” OPERATOR

QUALITIES

Education: Learns about the machine and the environment.

Alert: Stays alert at all times...never lets guard down.

Skills: Only performs duties he/she are qualified to do. Always tries to improve.

Judgment: Plays it safe. Doesn't take chances.

Common Sense: Does the right thing without having to be told. Applies knowledge.

Recognizes the Hazards: Maintains alertness. Anticipates danger.

Understands the Defense: Knows that safety isn't an accident...it's a thinking person's choice.

Acts Correctly: Does not cave in to pure pressure. Performs correctly when supervised or not.

2900HS SAFETY INSTRUCTIONS



Read and understand operators instruction manual and instructional video before operating this equipment.



WARNING: Know and understand before operation. Failure to do so could cause damage to equipment or bodily injury.

- Only qualified, trained personnel should operate this unit.
- Loose or damaged parts should be replaced immediately. Failure to do so could cause equipment damage or serious injury.
- Switches and levers should be inspected. (Disconnect battery charger from wall outlet and machine from batteries before repairs to prevent electrical shock). Do not use if defective. Power on/off switch should return to off when lever is released.
- Power control box, motor and switches should be completely enclosed at all times with no exposed wiring.
- Disconnect power from unit before servicing. Failure to do so can cause electrical shock. 
- Only use National components. Failure to do so could cause damage or serious injury.
- Always be aware of support personnel and their proximity when in operation. Block off work area.
- Support personnel should never stand next to machine, in front of or behind machine while machine is running. Failure to do so could cause serious bodily injury or death.
- Manual should be kept with machine in supplied holder for access by operator at all times.
- Always wear eye protection when running machine.
- Never defeat switches or guards.
- Remove blade when machine is not in use and/or lower cutting head to floor. Failure to do so could cause serious bodily injury.
- Wear gloves when changing blades. Always shut machine off when changing blades.



WARNING: Failure to follow any of the above instructions could cause damage to machine, damage to property or serious bodily injury or death.

2900HS BATTERY OPERATION

BATTERY OPERATION

180 amp hours

Batteries do not take a memory allowing recharge at any state.

Do not over discharge. Over discharging could cause damage to batteries.



REMOVING BATTERIES

⚠ WARNING: Service work on batteries should only be done by a trained professional. High amperage exists and can cause serious injury or death.

- Remove back lid
- Remove seat plate
- Disconnect back-up alarm
- Disconnect all wiring
- Remove batteries

REPLACING BATTERIES

- Reverse procedure from above. Replace all six batteries at the same time.
- Store in a safe dry place.

****See Battery Material Safety Data Information on pages 77-78**

⚠ WARNING: Remove all jewelry before servicing batteries.

⚠ WARNING: Service work on batteries should only be done by a trained professional. High amperage exists and can cause serious injury or death.

⚠ WARNING: Hood has pinch points. Do not get hands or fingers pinched when closing hood.

⚡ CAUTION: Electric shock hazard.

⚡ CAUTION: Use caution when connecting or disconnecting to avoid electrical shock.

⚡ CAUTION: Keep batteries dry.

2900HS BATTERY SAFE OPERATION

⚠ DANGER - RISK OF EXPLOSIVE GASES:

Chargers can ignite flammable materials and vapors. Do not use near fuels, grain, dust, solvents, or other flammables. Batteries generate explosive gases during normal operation. For this reason, to reduce the risk of battery explosion, it is important that each time, before using the charger, you read this manual a manufacturer of any equipment you intend to use in the vicinity of the batteries or battery charger. Review all cautionary markings.

⚠ CAUTION - PRECAUTIONS:

a) Contact with electrolytic acid can cause skin irritation and damage clothing. Wear a protective apron, gloves and goggles when working with batteries. Have plenty of fresh water and soap nearby in case battery acid contacts your skin, clothing, or eyes.

b) Remove personal metal items such as bracelets, rings, necklaces, and watches when working with batteries. A battery can produce a short circuit current sufficient enough to weld metal objects, causing severe burns.

c) Never smoke or allow a spark or flame in the vicinity of the batteries. Caution must be taken to reduce the risk of dropping metal tools onto the battery. A spark or short circuit may result in an explosion.

FIRST AID

Immediately flush eyes with cold, fresh water for a minimum of 10 minutes if electrolytic acid comes in contact with eyes. Seek professional medical attention.

VENTILATION

Blocking louvers or air flow perforations of convection or fan cooled battery chargers and/or machine will result in damage to the unit. When installing the unit leave space for air to flow freely through the intake and discharge louvers and/or perforations.

GROUNDING AND A/C POWER CONNECTION INSTRUCTIONS

The charger is equipped with an electrical cord with a equipment grounding conductor and grounding plug. The plug must be attached into an outlet that is properly installed and grounded in accordance with all local codes and ordinances.

⚠ DANGER

Never alter A/C cord or plug provided. If it will not fit the outlet, have proper outlet installed by a qualified electrician. Improper connection can result in electric shock.

2900HS BATTERY SAFE OPERATION

INSTALLATION

1) To provide maximum reliability, charger must be installed in a well-ventilated area, so that free airflow is not restricted through the side intake and exhaust vents.

2) Check polarity of battery posts. Positive (POS, P, +) and Negative (NEG, N, -). Attach positive (red) charger lead to the positive battery post. Attach negative (black) charger lead to the negative battery post.

⚠ WARNING: Do not disconnect DC charger leads during charging. Damage to the charger could result and void the warranty.

⚠ WARNING: Do not connect DC charger leads if the charger is connected to AC power. DC charger leads must be connected first.

COOLING TIME

Although it is not necessary, but if the batteries are allowed to cool back to room temperature after being charged, you will get more life out of the batteries and charge cycle.

BATTERY GENERAL INFORMATION

Batteries are designed to withstand high continuous shock load. They can be safely laid on the side, although keeping them upright at all time is suggested. Batteries are heavy, each battery is 63 pounds. Get help to remove batteries if weight is too much or you are under lifting restrictions. Do Not Drop.

When batteries have used their full life, they are recyclable at locations all over the US and Europe. Call National for recycle center. Batteries should only be maintained by certified National Technician.

Batteries are lead acid constructions. If packs are allowed to reach temperatures above 125° F, ventilation can occur and discharge explosive gases (see warning label). How is this done wrong? Improper charger's or improper connections, allowing for direct short.

BATTERY FREEZING

Freezing of the batteries will not be covered by warranty. Even though there is no liquid in the batteries, allowing batteries that are discharged below 75% to sit in temperatures below 20° F for more than twenty four hours can freeze. The colder the temperature the faster they will be damaged. Always recharge batteries before allowing to sit in cold temperatures or, hook to charger when conditions permit. This charging system can be left on the batteries (maintenance mode) for long periods without damaging the batteries.

SHIPPING

Unlike flooded cell or gel cell batteries, these batteries have no liquid in them so they can be shipped by air freight.

BATTERY WARRANTY

One year warranty stamped on battery label. All warranty is null and void if battery is tampered with or opened. Replace/maintain only by a National certified technician.

2900HS BATTERY SAFE OPERATION



WARNING: Do not put battery near fire.
Must be recycled or disposed of properly.
Do not touch terminals with metal objects.



BATTERY DISPOSAL

Battery must be recycled or disposed of in an environmentally sound manner.

Do not place used batteries in regular trash.

Do not expose the battery to fire or high heat as batteries may explode. Care must be taken not to short terminals together with metal objects: jewelry, keys, nails, screws, tools, etc. Do not attempt to disassemble battery, fire or injury may result. Prior to disposal, protect terminals with heavy insulating tape to prevent shorting.

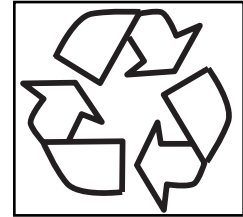

2900HS MACHINE CHARGING INSTRUCTIONS

MACHINE CHARGING

Machine has an on board charger (Figure A).

Note: Read & Understand charging manual before using g (pages16.1-16.4)

- To eliminate accidental machine start-up while machine is charging, turn off circuit breaker (Figure B) and depress E-Stop Button (Figure C) before connecting charger to a power source.
- Connect machine to power source using supplied 6 ft 12 gauge extension cord. **NOTE: IF NOT USING PROPER SIZED EXTENSION CORD COULD CAUSE IMPROPER CHARGING AND/OR CHARGER DAMAGE.**

NOTE:

A steady green light indicates machine is charging in standard charge cycle. Green light will blink when charging is complete and in maintenance mode.

***See Manufacturers Manual (included) for further Specifications**

- Complete charging sequence
- Disconnect cord from the power source. Make sure the cord/plug is completely secure back into the machine. Failure to do so could cause cord to fall under machine which will cause damage to cord and/or plug.
- Turn on circuit breaker
- Release E-Stop

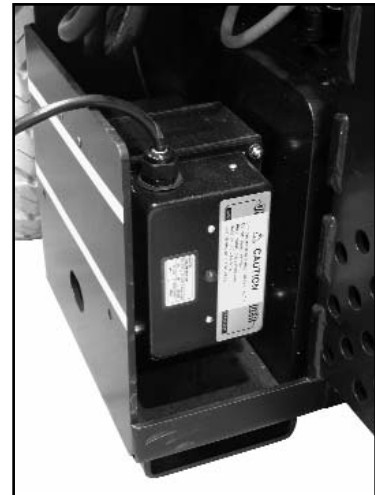

Figure A



Figure B



Figure C

⚠ WARNING: Always find a safe place for recharging power packs with good ventilation away from sparks or flame sources and away from bystanders. Rope off if necessary.

⚠ WARNING: Electrical shock hazard. Only use National's approved charging system.

⚠ WARNING: Disconnect from power source before operating. Failure to do so could cause damage to machine or bodily injury.

ON BOARD BATTERY CHARGER - MANUFACTURERS MANUAL



O P E R A T I N G I N S T R U C T I O N S

OBAE, OBAEXU, ON BOARD Battery Chargers

INTRODUCTION:

The OBAE line of chargers are designed for the permanent installation on battery powered vehicles and equipment. They are an electronically controlled two stage charger. The first stage brings the batteries to the gassing threshold where a three hour timer starts. The batteries are then gassed for three hours. After three hours, the charger drops into a low float mode where the charge is maintained in the batteries indefinitely. Finish current is below 1 amp.

SOME APPLICATIONS:

Golf cars, pallet trucks, personnel carriers, scissor lifts, floor scrubbers, stand-by power applications, robotics.

IMPORTANT: DO NOT USE THIS CHARGER UNTIL YOU HAVE READ ALL THE INSTRUCTIONS.

INITIAL INSTALLATION:

Before making AC connections, refer to the AC requirements labeled on the charger. If your charger is not equipped with an AC plug (*a 220 volt model*) have a qualified electrician install one.

▲ CAUTION: To reduce the risk of fire, use this charger only on circuits provided with a maximum of 20 ampere branch circuit protection (circuit breaker or fuse), In accordance with the National Electric Code, ANSI/NFPA 70, and all local codes and ordinances.

GROUNDING INSTRUCTIONS:

This battery charger must be grounded to reduce the risk of electric shock. If the charger is equipped with a grounding type plug, it must be plugged into a nominal 115 volt, 60 Hertz circuit. If the charger is supplied with no plug, have a qualified service person install one.

▲ WARNING: Improper connection of the equipment grounding conductor can result in a risk of an electric shock. **DO NOT USE THIS CHARGER ON A TWO POLE UNGROUNDED OUTLET OR ATTEMPT TO BREAK OFF THE GROUND PRONG FOR USE ON A RECEPTACLE OR EXTENSION CORD NOT HAVING A GROUND.**

The use of an extension cord with this charger should be avoided. The use of an improper extension cord result in a risk of a fire or electric shock. If an extension cord must be used, make sure it is in good condition. Use a three conductor cord no smaller than 14 AWG. And keep it as short as possible. Locate all cords so that they will not be stepped on, tripped over, or otherwise subjected to damage or stress.

Do not operate this charger if it shows any signs of physical damage.

ON BOARD BATTERY CHARGER - MANUFACTURERS MANUAL

PROPER CARE AND USE OF BATTERIES:

⚠ CAUTION: Always wear protective eye shields and clothing when working with batteries. Batteries contain acids which can cause bodily harm. Do not put wrenches or other metal objects across the battery terminal or battery top. Arcing or explosion of the battery can result. Do not wear jewelry when working around batteries. Arcing can cause severe burns.

New batteries will not deliver their full performance until after several cycles.

The tops of the batteries and battery hold downs must be kept clean and dry at all times to prevent excessive self discharge and flow of current between the battery post and frame.

Maintain the proper electrolyte level by adding water when necessary. Never allow the electrolyte level to fall below the top of the battery plates. Electrolyte levels fall during discharge and rise during charging. Therefore, to prevent the overflow of electrolyte when charging, add water **ONLY AFTER** the batteries have been fully charged **DO NOT OVERFILL**. Old batteries require more frequent additions of water than do new batteries.

Do not over discharge the batteries. Excessive discharge can cause polarity reversal of individual cells resulting in complete battery failure.

Provide adequate ventilation for the batteries and charger. Do not obstruct the flow of cooling air around the charger. Provide at least 1" of space around charger. Do not allow clothing, blankets or other material to cover the charger. Mount the charger firmly in place.

⚠ WARNING: Chargers can ignite flammable materials and vapors. Do not use near fuels, grain, dust, solvents, or other flammable's.

⚠ CAUTION: Before connecting the charger to the batteries, make sure the battery pack is of the same voltage rating of the charger. If you are unsure, count the number of cells on the battery pack and multiply by two. This figure should be the same as the DC voltage rating of the charger. (*see ratings label on charger*).

Below is an illustration of Parallel and Series battery packs.

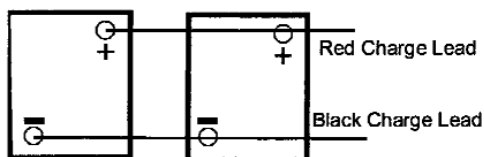

Parallel

When batteries are connected in parallel, the battery amp hour rating is additive, and the voltage remains the same. Example: Two 180 amp hour, 12 volt batteries would equal 12 volts, and 360 amp hours capacity.

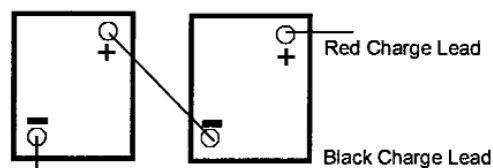

Series

When batteries are connected in series, the voltage is additive, and the amp hour rating remains the same. Example: Two 180 amp hour, 12 volt batteries would equal 24 volts, and 180 amp hours of capacity.

⚠ WARNING: Make sure the DC output leads, terminals or connector are all in good working condition.

ON BOARD BATTERY CHARGER - MANUFACTURERS MANUAL

DO NOT USE THIS CHARGER IF:

The DC output connector, (*if equipped*) is loose or does not make good contact; Is cracked or broken; The leads are cut or have exposed wires; The DC output leads or connector feel hot when used.

Using this charger with any of the above symptoms could result in a fire, property damage, or personal injury. Have a qualified service person make the necessary repairs. Repairs should not be made by people who are not qualified.

NORMAL OPERATION

- 1.) When connecting charge leads directly to the battery, apply grease to the terminals to inhibit corrosion.
- 2.) Plug the charger into AC power having the same ratings as that of the charger.
- 3.) The LED on the charger will light, indicating charge current is flowing.
- 4.) The OBAE chargers are equipped with a electronic timer. At the battery gassing threshold, (2.3 volts per cell) the timer will activate and run for three hours. During this period, the batteries are in a gassing or equalizing mode. (2.5 - 2.6 volts per cell max.) After three hours the charger will drop the batteries into a low float mode, indicated by a blinking LED. (2.26 volts per cell) Current in the float mode is less than 1 amp.

The charger may be left on indefinitely, but water level should be checked periodically on wet batteries.

- 5.) To discontinue charging, unplug the AC power cord. Plugging the AC power back in will cause the charger to repeat the cycle.

▲ WARNING: Do not disconnect the DC output leads or unplug the connector from the batteries when the charger is on. The resulting arcing could cause the batteries to explode. If the charger must be stopped unplug the AC power.

▲ WARNING: Failure to unplug AC power before moving or driving equipment will result in damage to cords, plugs and receptacles.

TROUBLE SHOOTING:

▲ CAUTION: DO NOT DISASSEMBLE THE CHARGER. Incorrect assembly may result in a risk of electric shock or fire. Contact factory.

▲ DANGER: To reduce the risk of electric shock, always disconnect both the AC power supply cord and the output leads or connector before attempting any maintenance cleaning.

1). LED DOES NOT COME ON WHEN POWER IS APPLIED

Be sure you are plugged into a live circuit. Check the AC cord for breaks in the cord or plug. Check the DC leads for breaks. Check the DC connections to the battery, clean if heavily corroded.

Place a volt meter across the battery terminals where the charger is connected. Apply AC power. If the voltage rises on the battery, the charger is working and the LED is defective. *NOTE:* LED's do not burn out, but it has probably received a sharp blow causing physical

ON BOARD BATTERY CHARGER - MANUFACTURERS MANUAL

damage. No harm will come from operating the charger without a working LED.

2). LED NEVER BLINKS

This could be one of two problems. The batteries never reached timer trip voltage and the charger was unable to gas and fall into the float mode. This indicates several shorted cells. Overheating and excessive water usage are symptoms of this condition. Performance will also be greatly diminished. Replace defective battery.

The charger did reach the float mode, but the battery has one or more shorted cells inhibiting the charger current to fall low enough to start the LED blinking. Replace defective battery.

3). AC LINE FUSE OR CIRCUIT BREAKER BLOWS

Either the circuit breaker or fuse is weak, or the charger is shorted internally.

4). NO POWER IS PRESENT ACROSS THE DC LEADS WHEN A VOLT METER IS CONNECTED

Good. The charger will not turn on until leads are connected, correct polarity to the battery.

5). BATTERIES DON'T RECEIVE FULL CHARGE

The battery you are charging may be too large for the charger, or if you have the charger plugged into a long extension cord that is too small, a voltage drop will cause a decrease in charger output, extending charge times.

OBAE Battery Chargers "LIMITED WARRANTY"

National Flooring Equipment, Inc. (National) warrants the OBAE line of chargers for one (1) year from the date of purchase.

After the warranty period, chargers returned to the factory for repair will be charged a minimum rate of \$25.00. Charger will be returned, freight and repair charges, C.O.D. unless other arrangements have been made.

This warranty covers all defects in manufacture and performance, provided the unit is operated in compliance with manufacturer's operating instructions.

For repairs to be made at:

National Flooring Equipment, Inc.
9250 Xylon Avenue North
Minneapolis, MN 55316

National, at its option, repair or replace the charger or component in question. The repaired item will then be returned. This warranty is void if the charger or component have been altered, changed, or repaired by anyone not authorized by National, or if the charger or component have been subject to misuse, negligence, or harsh environmental conditions. (Except those chargers designed for such conditions).

If returning the charger to the factory is not practical, replacement parts may be shipped to the customer for field repair at no charge. On parts such as circuit boards, the customer will be required to return the board suspected to be defective to National, freight prepaid. If such defective parts are not returned, the customer will be invoiced for the repair parts.

Field repairs are made at the user's own risk. "Authorization" by National to repair refers to maintaining the warranty only. National assumes no responsibility or liability for field servicing, and shall not be responsible for incurred travel or labor charges.

National shall not in any event be liable for the cost of any special, indirect or consequential damages to anyone, product or thing.

This warranty is in lieu of all other warranties expressed or implied. National neither assumes nor authorizes any representative or other person to assume for us any liability in connection with the sale of this product.

2900HS BATTERY OPERATION

COMMONLY ASKED QUESTION

- 1. Question:** When the charging battery has not been fully discharged will it take a memory set?
Answer: No, the design of these batteries allow charging at any stage of discharge without memory problems.
- 2. Question:** Do I lose a complete cycle when I charge batteries that are only partially discharged?
Answer: No, battery design allows for recharge but only loses one complete cycle when fully discharged.
- 3. Question:** Does the battery slow down as it discharges?
Answer: No, this design will give full power to 90% of the battery cycle. This drop off in the last 10% allows extra time to get back to your charger or extra packs.
- 4. Question:** Can the battery spill?
Answer: No, unlike other batteries, there is no liquid to spill out which allows for high shock load applications.
- 5. Question:** Will batteries go dead?
Answer: No, the battery design will hold up to 90% of its' charge up to 2 years without being used or charged.
- 6. Question:** Does severe cold effect the batteries?
Answer: If fully charged, no. If allowed to warm up (room temperature) battery will perform better. If battery is under 75% charge, severe cold will destroy the battery.
- 7. Question:** Do I have to let batteries cool down after charge?
Answer: No, but if you do, you will get more life out of the battery.
- 8. Question:** Can the battery overheat and discharge gases?
Answer: Yes, if improper charge is used or the battery heats to over 125° FH, gases off the vents inside of the batteries is possible. Caution must always be taken when charging batteries. Charge in a good ventilated area, away from sparks and open flame and away from bystanders.
- 9. Question:** Can I leave the charger on too long?
Answer: No, our charging system is designed to read batteries state of charge constantly if left on for long periods of time (over the weekend) it will not hurt batteries or cause over charging problem.
- 10. Question:** Can I leave the charger running while I am running the machine?
Answer: No, the charger must be unplugged from the power supply before using.

2900HS FEATURES/SPECIFICATIONS

#2900HS

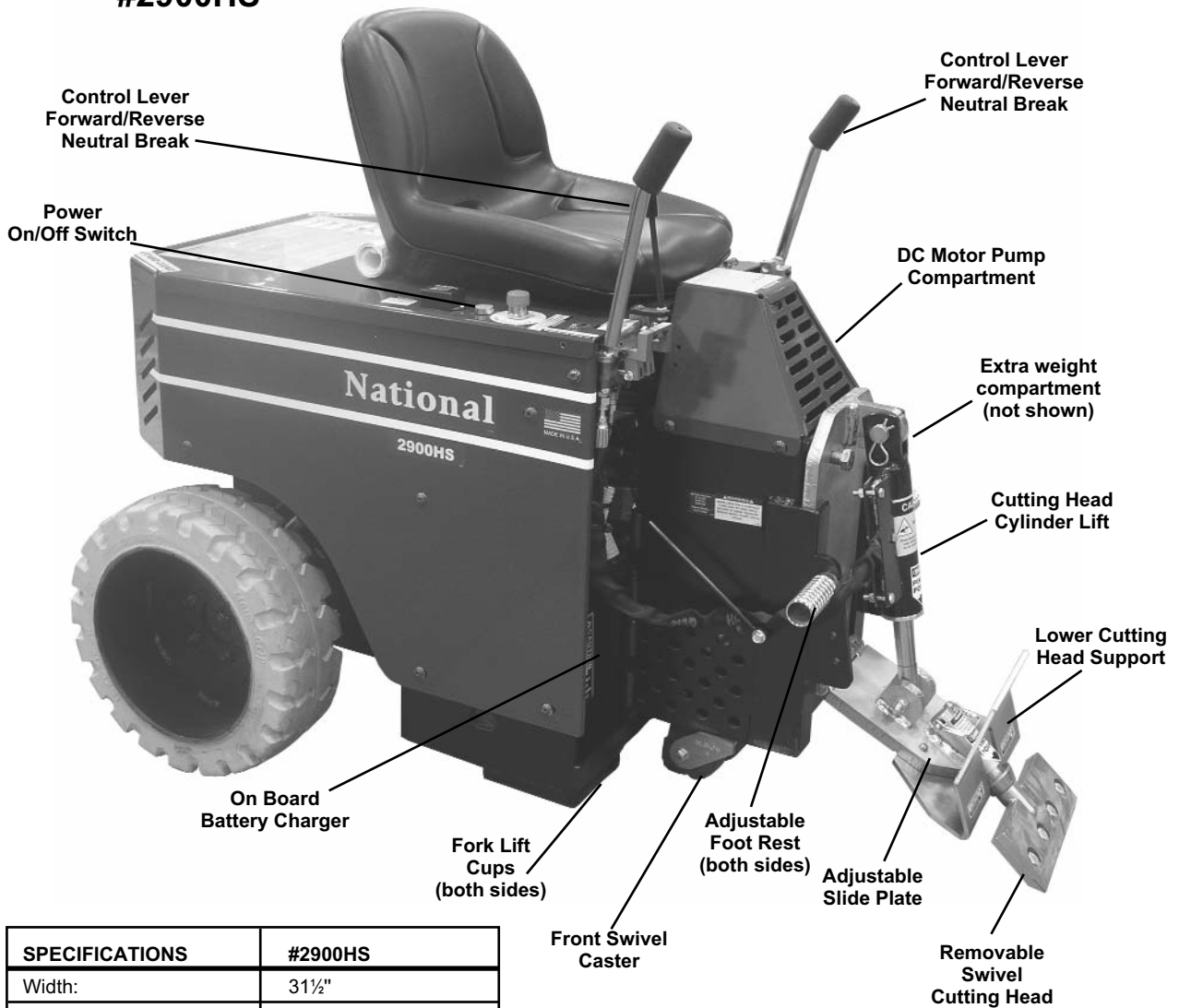

SPECIFICATIONS	#2900HS
Width:	31½"
Height with seat:	44"
Length without Jaw:	53"
Empty Weight:	1595 lbs.
Fully Weighted:	2110 lbs.
Added Weight:	
Removable Pocket Wt.:	432 lbs
Removable Back Wt.:	83 lbs.
Removable Front Wt.:	N/A
Removable Side Wt.:	N/A
Front Assembly:	100 lbs.
MOTOR INFORMATION (#2900HS)	
Speed:	Up to 160 feet pr min.
RPM:	2200
Volts:	48
HP:	5
Amps-Full Load:	100
Continuous Duty	

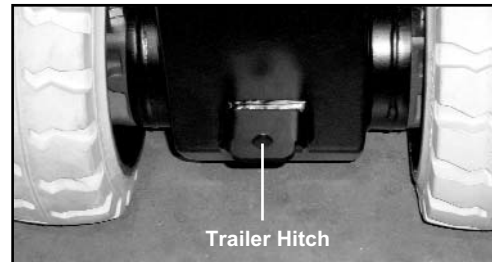

⚠ WARNING: Trailer hitch is only intended to move small trailers on the job site.

2900HS FEATURES/SPECIFICATIONS

VIBRATION/SOUND DATA

VIBRATION DATA:

Axis	Stationary	Moving
X	>0.1	0.5
Y	0.3	0.3
Z	0.4	0.1
Vector Sum	>0.1	0.6

Whole Body
Vibration Levels in m/s^2

Axis	Left	Right
X	0.5	1.4
Y	0.3	1.4
Z	0.6	0.5
Vector Sum	0.9	2.0

Hand/Arm
Vibration Levels in m/s^2

SOUND DATA:

	dBA
Stationary	77.0
Moving	73.0

Operator Sound Level
dBA ref. 20 Pa

2900HS OPERATING CONTROLS

POWER ON SWITCH (FIGURE A)

Never use the power on/off switch as a method for speed control. Speed control is achieved by the hydraulic valve only. Using the on/off switch repeatedly will cause excessive wear, causing premature replacement of electrical components. An Emergency Stop Switch (E-Stop) is located by right hand (Figure B). To start machine, the E-Stop switch should be up (green band will be visible). There is also a seat safety switch (operator must be properly seated for machine to operate). Push the on/off button to start machine.

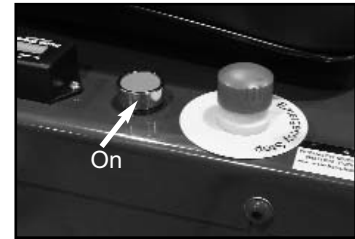

Figure A

MACHINE START-UP PROCEDURE (FIGURE E)

- Verify 70 amp circuit breaker is in “On” position (Figure C)
- Verify 48-volt blue plugs are firmly connected (Figure D)
- Operator should be properly positioned on seat
- Twist E-Stop (Figure B) to “up” position exposing green ring
- Push green “on” button
- Maneuver machine with hydraulic levers (see instruction below)



Figure B

HYDRAULIC LEVERS (FIGURE E)

The hydraulic levers steer the machine. They are feathered spool valves. For smooth even movement, always move **levers slowly**. Fast movement on control levers will result in jerky, uneven movement.

- Move levers slowly.
- Both levers forward **↑↑** move the machine forward.
- Both levers backward **↓↓** move the machine backward.
- The left lever forward and the right lever backward **↑↓** turn the machine quickly to the right.
- The left lever backward and the right lever forward **↓↑** turn the machine quickly to the left.
- Only using the left or right lever forward **↑**, turns the machine slowly to the right or left.
- Only using the left or right lever backwards **↓**, turns the machine slowly to the left or right.
- Correcting direction while moving forward is accomplished by slightly reducing pressure on one lever or the other while moving.
- The center position on levers causes wheels to lock-up.
- Always chock wheels and tie down machine when transporting.

Control levers are low in vibration.



Figure C

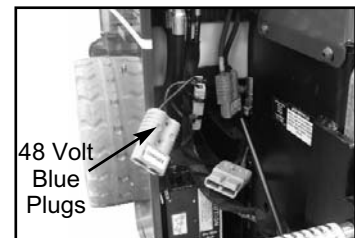

Figure D

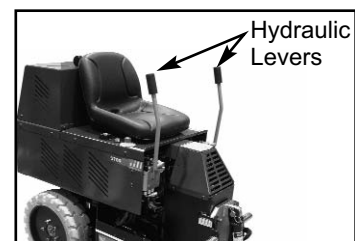

Figure E

2900HS OPERATING CONTROLS

EMERGENCY STOP SWITCH (FIGURE A)

The emergency stop switch is designed to kill the power to the system.



Figure A

SEAT SWITCH

The seat has a safety switch. Operator must be properly positioned for machine to run.

TO STORE MACHINE (FIGURE B & C)

When the machine is in storage, remove the blue connections and turn circuit breaker to off. This will help to keep someone from operating the machine when it shouldn't be.

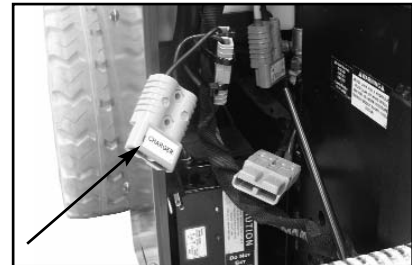

Figure B

CYLINDER LIFT (FIGURE D)

The cylinder lift lever raises and lowers the cylinder and cutting head. After setting slide plate to proper height, use the cylinder lift lever to set blade to proper cutting angle. Pull back ↓ on the cylinder lift lever to raise the cutting head. Push the cylinder lift lever forward ↑ to lower the cutting head. Continuing to push the cylinder lift lever forward and it will adjust the angle of the cutting head. This will also jack up the front of the machine (Figure E). This will need to be done when doing maintenance on the machine (ie: wheel changing, front caster maintenance etc). When doing machine maintenance, besides raising the cutting head angle, place blocks under the machine (Figure F). Never use the cutting head only.

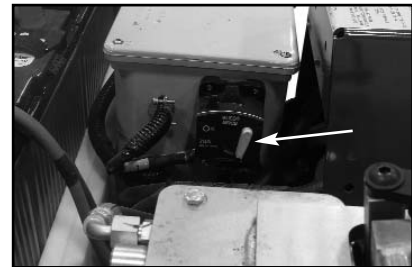

Figure C

⚠ WARNING: Do Not alter a switch or lever. Do Not defeat a safety device.

⚠ WARNING: Disarm machine by removing the cutting head or dropping the cutting head to the floor when the machine is not in use.



Figure D

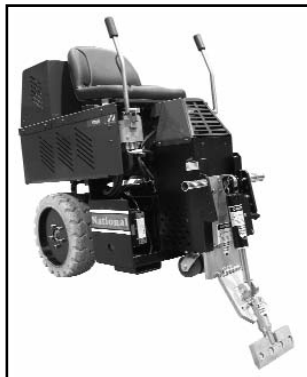

Figure E

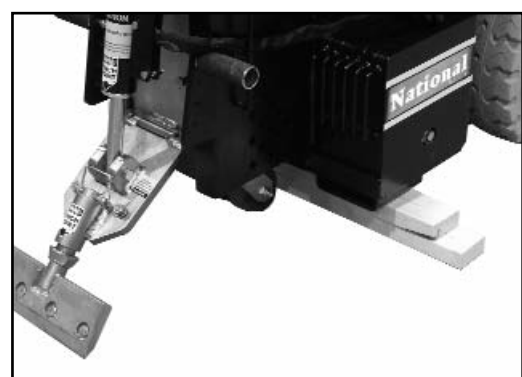

Figure F

2900HS OPERATIONAL TIPS

CASTER

Keep clean and free of debris, make sure it can move freely. Clean as needed. Inspect before each use. Grease once a month.

Moving a "weighted" machine only on the front caster and not on the cutting head or the Front Wheel Assembly can seem to make the machine turn sluggish. It might turn hard to the right or the left. This is normal.

FOOT PEG

Keep feet resting and secured on foot pegs when operating machine. Foot pegs are adjustable. Make sure securing nut is securely tightened

SEAT

Always be properly seated before operating machine. Machine will not run if the operator is not properly seated

DISARM MACHINE

Remove blade or drop cutting head to the floor when machine is not in use.

TURN MACHINE OFF

Never change cutting head or service blade while machine is running.

LEAKAGE

Keep fittings and hoses tight. If a leak is noticeable, retighten fitting. If leakage persists, remove the connection and inspect.

ANGLE OF THE HEAD IS SET STEEP

When raising the front of the machine to a steep angle, the bottom of the slide plate should be raised so it is higher or even with the bottom of the guide channels, 6" to 7" off the floor. This will allow for a steep blade angle without tipping the machine too far back (usually used for re-scrape). The most common mode for take up, is the slide plate is almost to the floor (1/4" to 1/2" from the floor).

RAISING OR LOWERING THE SLIDE PLATE

This will only work without a cutting head inserted in the machine. Completely loosen slide plate bolts. Use cylinder lift lever to raise or lower machine to move slide plate up or down.

 **WARNING:** Always disconnect on board charger before operating machine.

2900HS LOADING/UNLOADING

- Always remove blade and cutting head when machine is being moved or transported
- Cutting head and slide plate can be removed to make the machine more compact.
- NEVER leave machine unattended on an incline.
- Removing added weights help to make the machine easier and safer to move in and out of a vehicle.

⚠ WARNING: Machine has a swivel front caster. **Never** side hill (Figure A). The machine on a incline without power, the front caster will cause machine to swing to the lowest point. If it is necessary to run machine on an incline, run machine on cutting head. Place at least a 8" cutting head in machine. To keep from damaging floor, clamp a piece of carpet into cutting head to slide on the floor. This will give positive contact with the floor when power is disengaged from the wheels.

DOCK HEIGHTS

It is best to load or unload the machine from a level/equal dock height (a van from a van dock height, a truck/semi from a regular dock height).

POWER-GATE

A power-gate can be used when the dock height is not available. Make sure gate is properly rated for 2300 lbs. Make certain the machine is secure so it does not roll off the power-gate. To better secure machine, raise machine onto the lowered cutting head, raising machine off the caster. Tie machine down, chock wheels.

RAMPS

To be safe, the ramp needs to be very long to accommodate the machine being loaded/unloaded. Remove added weight. Make sure ramp is secured. Do not have at a steep incline. The use of a power winch or hand come-a-long is much safer. For a van, the ramp should be 12 to 18 feet in length depending on the depth of the incline. For truck height taller than a van, longer ramps will be needed. See OSHA guidelines. It is not recommended to drive the machine, connected with power, on a ramp. Make sure ramp is secure and has good contact before using. Failure to do so could cause ramp to fall away from the vehicle.

Note: See correct and safe operating angles and center of gravity on page 25.

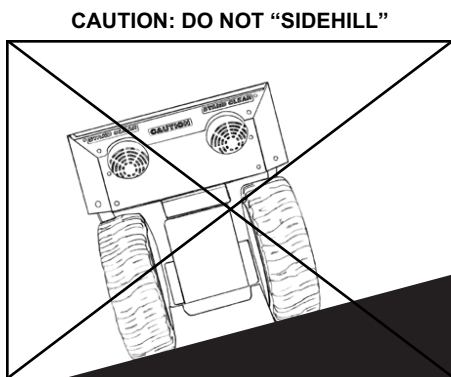
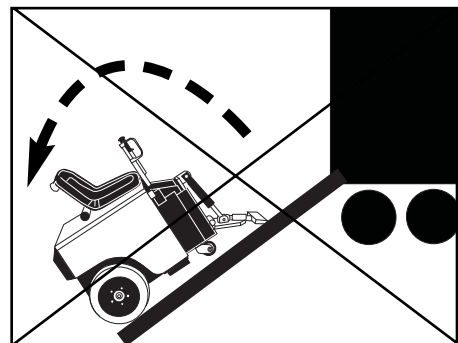

Figure A

CAUTION: MACHINE IS BACK HEAVY.
DO NOT RUN ON STEEP INCLINE--
THIS COULD CAUSE MACHINE TO TIP OVER!



2900HS LOADING/UNLOADING

FORKLIFT CUPS

There are two forklift cups mounted under the front of the machine (Figure A). Slide fork lift forks through forklift cups. Slide forks all the way back to touch the rear tire (Figure B). Before lifting machine, secure machine to fork lift with heavy 3000 lb. or heavier rope or chain. Tilt forks back to lift machine Figure C).

▲ WARNING: Never tilt machine forward. It could slide off fork lift forks.

WINCHES

Winches should be used for safety when loading or unloading with ramps. 2000 lb. winch minimum.

TRANSPORTING

Secure machine down with ratchet straps when transporting the machine. Chock wheels to keep machine from rolling, hydraulic levers should **not** be locked in the forward or backward position. Hydraulic levers should be straight up in the "neutral" position. This helps to lock drive wheels. Lift machine off swivel caster by lowering cutting head for better stabilization. Proper securing straps need to be rated at least twice the weight of the machine.

WHEEL CHOCKS

Wheel chocks will help to secure the machine but DO NOT use wheel chocks alone to secure the machine.

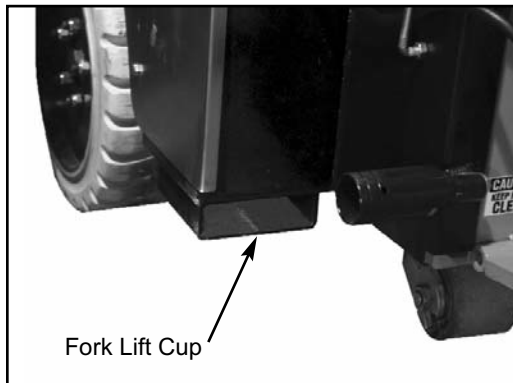

Figure A

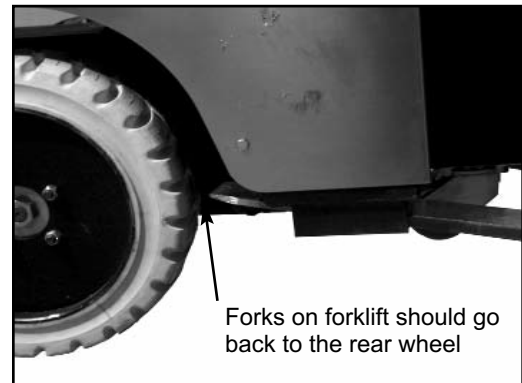

Figure B

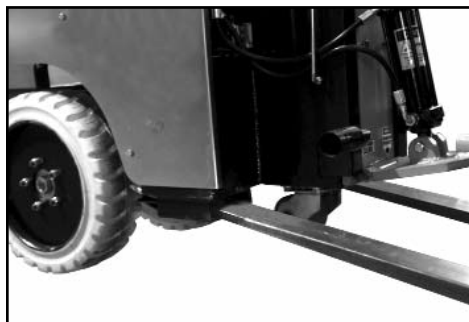
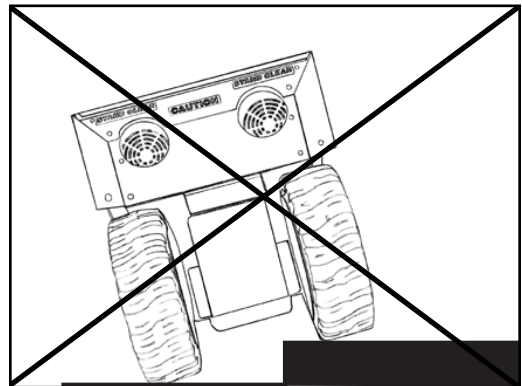
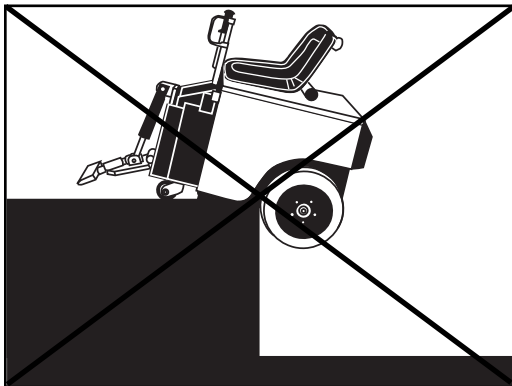
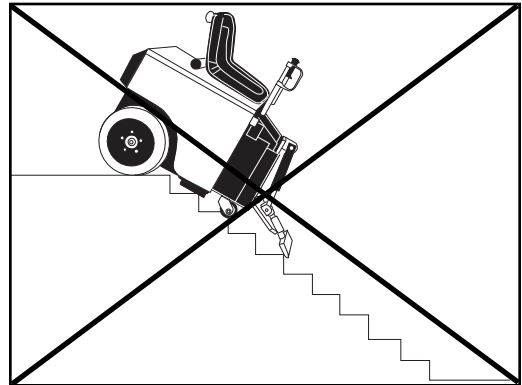
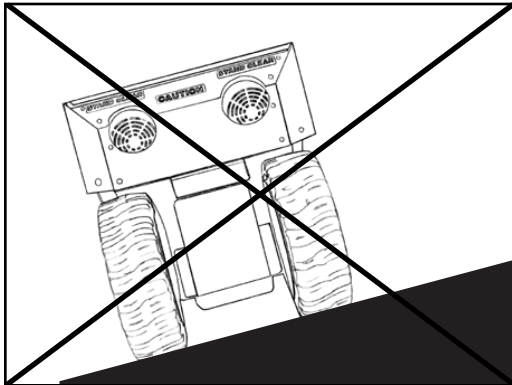

Figure C

2900HS CENTER OF GRAVITY

Be aware of your surroundings and machines operating angles. When changing from a low slide plate to a high slide plate setting or a low cutting head angle to a high cutting head angle, the operating “attitude” of the machine changes. When a floor surface is not level (ramps, inclines, large amounts of debris which would lift the drive wheel of the machine, etc.), the center of gravity changes. Too much of an angle could make the machine unsafe (a cause for tip-over). **Do Not** run the machine in unsafe environments.



**CAUTION: MACHINE IS BACK HEAVY.
DO NOT RUN ON STEEP INCLINE--
THIS COULD CAUSE MACHINE TO TIP OVER!**

**CAUTION: MACHINE IS BACK HEAVY.
DO NOT RUN ON STEEP INCLINE--
THIS COULD CAUSE MACHINE TO TIP OVER!**

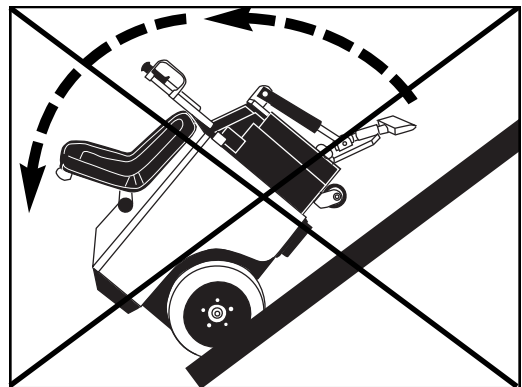
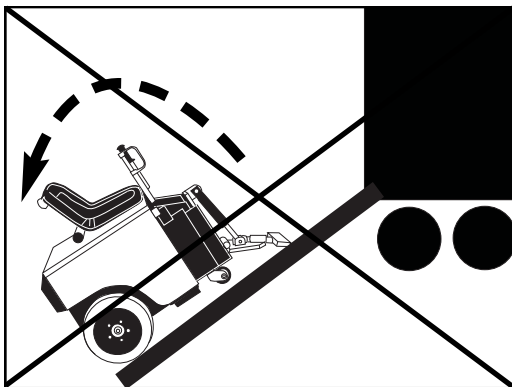

2900HS JOB SITE MOVEMENT

- Always remove blade and cutting head when machine is being moved or transported
- Cutting head and slide plate can be removed to make the machine more compact.
- NEVER leave machine unattended on an incline.
- Removing added weights help to make the machine easier to move.

TAPING WHEELS

Taping the wheels with a wide like masking tape helps to prevent damage and dirt to floors during move-in and move-out.

LEAP FROGGING BOARDS

Leap frogging boards help to protect floors from damage. Use two or three ¼" luan or plywood sheets, approximately 27" wide by 6' long. Cover one side of the board with a thin a carpet. With the carpet side to the floor, place a board in front of the machine. Drive onto the board. Set the next board in front of the machine. As you drive off one board, pick it up and set it in front of the machine.

PALLETIZING

Only use a solid platform pallet. If a solid platform pallet is not available, place a piece of ¾" plywood on top of a pallet. Using a forklift with the forks inserted in the forklift cups, place machine on pallet. Use ratchet straps to secure machine to pallet.

FRONT WHEEL ASSEMBLY (FIGURE A)

The Front Wheel Assembly is an optional attachment (#5110-100) that is very helpful when moving the machine around on a job-site or loading the machine that is not on a pallet. It allows machine stability and safe transportation over most surfaces. It is easy and quick to attach or detach. Raise slide plate so the bottom of the slide plate is higher or even with the bottom of the guide channels. Raise cylinder, insert Front Wheel Assembly into cutting head. Secure with securing pin.

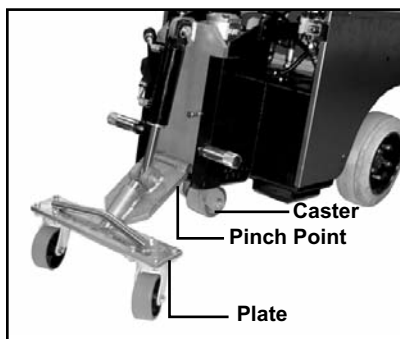

Figure A

Note: Make sure the plate is parallel with the floor so the caster swivels freely.

CAUTION: When moving the slide plate, be aware of pinch point at the bottom of the plate. Failure to do so could cause serious bodily injury.

WARNING: Protect others in work area. Provide barriers or shields as needed to protect others from debris and machine operation. Operator should be aware of who is around them and their proximity.

2900HS JOB SITE MOVEMENT

TO MOVE MACHINE WITHOUT POWER (PUSHING MACHINE)

Forward: To move the machine forward, levers need to be pushed forward. To lock levers in place, connect a bungee-strap from each lever (pushing levers forward), pulling straps down to and connecting to the front plate (Figure A). Never leave machine unattended with strap holding levers open.

Backward: To move machine backward, levers need to be pulled backwards. To lock levers in place, connect a bungee-strap from each lever (pushing levers backward), Pulling straps to the back of the machine and connecting behind the seat or the rear of the machine (Figure B). Never leave machine unattended with strap holding levers open.

MOVING MACHINE ON CASTER

Moving a "weighted" machine only on the front caster and not on the cutting head or the Front Wheel Assembly can seem to make the machine turn sluggish. It might turn hard to the right or the left. This is normal.

⚠ WARNING: Always remove straps before starting motors. Failure to do so will make machine move and may cause property damage and/or bodily injury.

FORWARD



Figure A

BACKWARD



Figure B

2900HS WHEEL SIZES

WHEEL SIZE

The 18" wheel comes standard on the machine. This wheel will work on all job types of application and heavy debris build-up (vct, ceramic etc.). It also works best for slippery/slimy residue, ie. double stick.

Keep wheels clean and free of debris, make sure it can move freely. Clean as needed. Inspect before each use.

To change wheels, see Wheel Changing on page 42.

 **WARNING:** When doing maintenance or changing a wheel, make sure machine is supported properly or serious injury could occur.

2900HS CUTTING HEAD & BLADES

DIALING IN THE MACHINE

Dialing in the machine is matching the correct cutting head, blade size, blade angle and added weight to the machine to make the material removal as easy as possible. For every material being removed, there is an optimum blade width, thickness, sharpness, angle and bevel (bevel up or bevel down).

SAVING TIME WITH EXTRA CUTTING HEADS

The machine is supplied with one cutting head. Having additional cutting heads will save time on the job. Insert blades into the extra cutting heads before starting a job. When the blade is dull, instead of taking the time to replace it or sharpen it on the job, take out the cutting head and replace it with another. Or when a different type or size of blade is needed, you have them ready to use.

ADJUSTING SLIDE PLATE AND CUTTING HEAD (FIGURE A & B)

Caution: Pinch point. When adjusting slide plate, keep feet and hands out from underneath the cutting head and slide plate. Failure to do so could cause severe bodily injury. When bolts are removed from the slide plate, the cutting head and the slide plate will drop down to the floor.

- Loosen the two bolts on the front of the slide plate with a 3/4" wrench (Figure C).
- Slide plate up or down to achieve the desired height of the cutting head.
- Firmly retighten both bolts.

SHEAR POINT

The shear point is the point where material to be removed will cut cleanly from the floor. If the blade is too wide, too dull, or too steep, the shear point is lost.

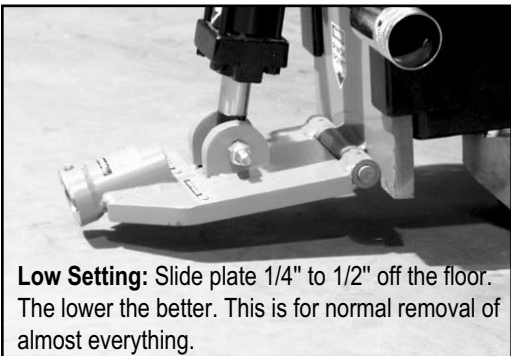

Figure A

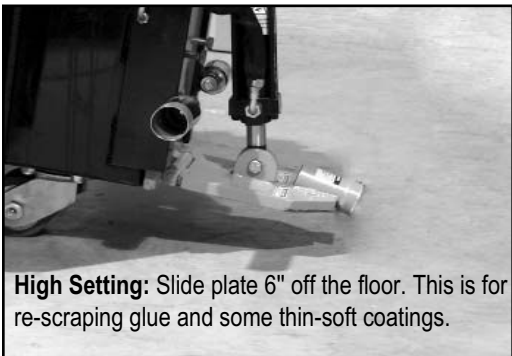

Figure B

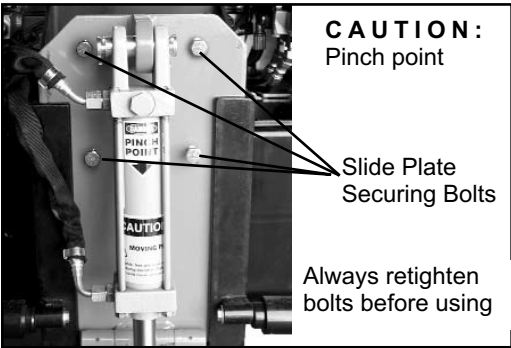

Figure C

CAUTION: Blades are sharp, use extreme caution.

CAUTION: Never change cutting head or service blades while machine is running.

WARNING: Disarm machine when machine is not in use. Remove the cutting head or drop cutting head to the floor. Failure to do so could cause severe bodily injury.

2900HS CUTTING HEAD & BLADES

WEIGHT VS. SHARPNESS

The most common way to compensate for a dull blade is to add more weight and raise the blade angle (see re-scrape setting). Weight allows dull blades to be used to a point. Weight also causes blades to dull and break easier. Blades of any thickness tend to catch cracks and expansion joints and will bend or break the blade if set at a high angle. For best results, run a small ditching blade at a low angle to identify as many cracks and joints as possible. If blades are breaking, you are misunderstanding the conditions.

CUTTING HEAD ANGLE

Set the cutting head angle to where the material comes up the easiest. The lowest is usually the best.

STEEP CUTTING HEAD ANGLE

A steep angle is only used for re-scraping. The slide plate has to be raised so the bottom of the slide plate is higher or even with the bottom of the guide channels (Figure A). Not raising the slide plate when operating the machine at a steep angle will cause the machine to jump and buck. It does not give the operator a clear vision of the cutting head and it raises the machine to operate at an unsafe operating height (Figure B). Failure to raise the slide plate could cause machine damage and/or bodily injury.

SWIVEL HEAD

The swivel head keeps the blade in contact with the floor even when the floor is uneven. When using a flat blade, by swiveling the head over 180° allows another sharp edge on the blade without having to replace the blade.

SAVING TIME WITH EXTRA CUTTING HEADS

The machine is supplied with one cutting head. Having additional cutting heads will save time on the job. Insert blades into the extra cutting heads before starting a job. When the blade is dull, instead of taking the time to replace it or sharpen it on the job, take out the cutting head and replace it with another. Or, when a different type or size of blade is needed, you have them ready to use.

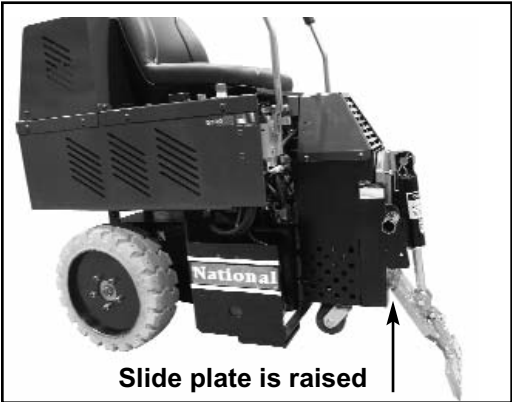

Figure A

Correct slide plate setting with a steep cutting head angle.

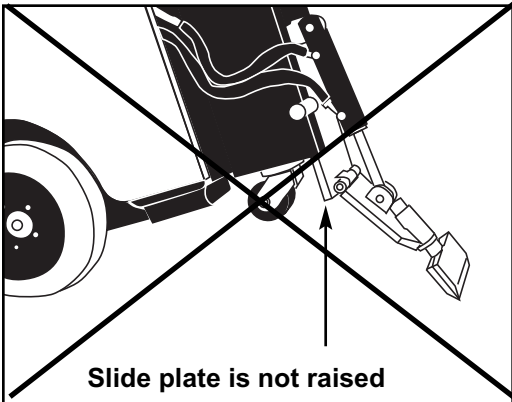

Figure B

Incorrect slide plate setting with a steep cutting head angle.

⚠ CAUTION: Watch out for obstructions in the floor (ie. expansion joints, nails, bolts, receptacles). They will break blades.

2900HS CUTTING HEAD & BLADES

CUTTING HEAD INSERTION

With machine off, insert desired cutting head into cutting head holder. Secure with cutting head clip.

SHANK BLADE INSERTION

Shank blades do not require a cutting head. Insert desired shank blade into cutting head holder. Secure with cutting head clip.

BLADE SETTING

- Dull blades greatly reduce cutting ability. Re-sharpen or replace as needed.
- Proper blade size and placement, depending on material and sub-floor type, affects performance.
- The harder a job comes up, for best results, use a smaller blade.
- Start with a narrow blade, then increase blade size to optimize cutting pass. Narrower blades work easier than wider blades and usually clean the floor better. Wider is not always better or faster.
- Normally bevel on blade is up for concrete. Bevel down for wood and shoe blades for soft sub-floors.



**BEVEL UP
CONCRETE FLOORS**



**BEVEL DOWN OR
SHOE BLADES
WOOD FLOORS**

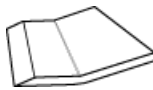

**SHOE BLADE
SOFT SUB-FLOORS**

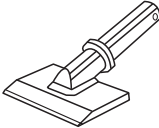

- KEEP BLADES SHARP.
- Dull blades greatly affect the performance of the machine and reduce cutting ability, resharpen or replace as needed.
- Keep your work area clean and clear of debris.
- After you have removed a portion of material, remove it out of the way. This will give the machine maximum performance and help to keep the work area safe.
- Always wear gloves when handling blades.
- Everyone in work area should wear eye protection.

SELF-SCORING BLADES

Instead of pre-scoring a job, for soft goods (carpet, vinyl, linoleum, membrane) the self-scoring blades automatically do the scoring.

BLADE INSERTION OR BLADE CHANGING

Using a 3/4" socket wrench, loosen bolts on cutting head. Quantity of bolts will vary depending upon cutting head size. Insert blade into the cutting head to back of notch (Figure A). Tighten firmly.

Note: A cordless 3/8" drive impact wrench will speed up this process especially out on the job.

- Sharp blades are imperative for good performance. • Always wear gloves when handling blades.

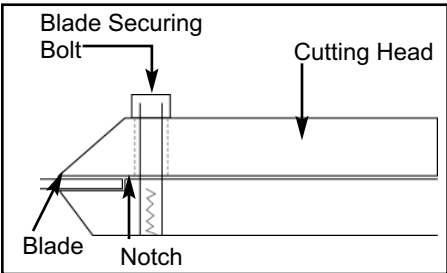

Figure A

CAUTION: Blades are sharp, use extreme caution.
CAUTION: Never change cutting head or service blades while machine is running.
WARNING: Disarm machine when machine is not in use. Remove the cutting head or drop cutting head to the floor. Failure to do so could cause severe bodily injury.

2900HS BLADE APPLICATION/SET-UP

CERAMIC SET-UP

Slide plate should be set low, 1/4" to 1/2" off the floor. Use a Shank Blade or a Shank Blade with a carbide tip.

WOOD SET-UP

Slide plate should be set low, 1/4" to 1/2" off the floor. Use Shank Blades, Shank Blades with carbide tips or a 6" or 8" Cutting Head with Shoe Blades, Bent Shoe Blades or Heavy Duty Blades. Note: run machine 45° to the grain of the wood.

SECONDARY BACKING CARPET SET-UP

Slide plate should be set low, 1/4" to 1/2" off the floor. Use a Cutting head from 10" to 27" with Heavy Duty Blades or a Cutting Head from 10" to 14" with a Self-Scoring Blade.

FOAM BACK CARPET SET-UP

Slide plate should be set low, 1/4" to 1/2" off the floor. Use Cutting Heads from 10" to 14" with Self-Scoring Blades. If it is not stuck tight, use a Cutting Head from 14" to 27" with a Standard Blade.

DOUBLE STICK CARPET SET-UP

Slide plate should be set low, 1/4" to 1/2" off the floor. It is best to test to see which is the easiest way to remove double stick. Start with a Cutting Head from 10" to 14" with Self-Scoring Blades. If self-scoring blades do not work, score thru the carpet (Figure A) the width of the blade (Standard Blade) and scrape up. In some cases, carpet might pull off the pad and then scrape up the pad separately. Usually leaving carpet connected to the pad works the best. Sharp blades are necessary for proper operation.

VCT TILE SET-UP

Slide plate should be set low, 1/4" to 1/2" off the floor. If goods come up easily, change to a larger Cutting Head. If goods come up harder, use a Cutting Head from 6" to 8" with a Premium High Tempered Blade (.062) to match cutting head size. Sometimes a .094 blade may work better. If goods remove easily, a Tile Box #7074 can be used. A tile box also works for wind rowing, assists for a fast clean-up and collection of tile debris for quick removal.

DITCHING (see page 32)

RUBBER TILE SET-UP

Slide plate should be set low, 1/4" to 1/2" off the floor. Use a Cutting Head from 6" to 14" with self-scoring blades or use ditching method with a flat blade (see page 34).

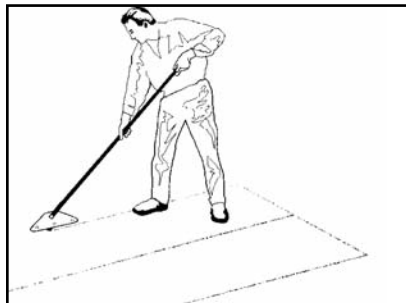



Figure A

CAUTION: Blades are sharp, use extreme caution. 

CAUTION: Never change cutting head or service blades while machine is running.

WARNING: Disarm machine when machine is not in use. Remove the cutting head or drop cutting head to the floor. Failure to do so could cause severe bodily injury.

2900HS BLADE APPLICATION/SET-UP

RE-SCRAPING SET-UP

Slide plate should be set high, 6" to 8" off the floor. Use a Cutting Head from 8" to 27" with Scrapper Blades to match cutting head size. A 15" scrapper blade would use a 14" Cutting Head. Razor Blades are faster but a Cutting Head from 8" to 14" can be used with a Standard Blade. Flip head regularly.

THIN COATING SET-UP

Slide plate could be set high, 6" to 8" or low 1/4" to 1/2" off the floor. Test to see which works best. Use a Cutting Head from 8" to 27" with Razor Blades to match cutting head size.

WORKING OVER CONCRETE

Blade should be bevel up when working over concrete. Pretty much anything over concrete works. Try different set-ups to see which works best. If goods come up difficult, slide plate should be at a low setting, 1/4" to 1/2" off the floor. Use a smaller size blade. If goods come up easily, a wider blade can be used.

WORKING OVER WOOD

A heavy machine cannot be used on wood subfloors or raised panel computer floors. Keep machine light, remove all weights. A weighted machine could break through the floor. Slide plate should be set low, 1/4" to 1/2" off the floor. Blades should be as flat of an angle as possible. Use a "shoe blade", Extra Heavy Duty Blade (these blades have a bend to them) or a regular blade, bevel up. When using a regular blade, bending up the corners of the blade will help from the blade digging into the floor. Sometimes a shank blade or a shank blade with a carbide tip will work. Allow blade to shear material from the floor. The trick on wood floors is to run the blade flat. Approach should be at a 45° angle to the board. This keeps from digging into the board and hanging up at the seams.

WORKING OVER SOFT SUB-FLOOR

Slide plate should be set low, 1/4" to 1/2" off the floor. Blades should be as flat of an angle as possible. Use a "shoe blade", Extra Heavy Duty Blade (these blades have a bend to them) or a regular blade, bevel up. When using a regular blade, bending up the corners of the blade will help from the blade digging into the floor. Sometimes a shank blade or a shank blade with a carbide tip will work.

 **CAUTION:** Blades are sharp, use extreme caution. 

 **CAUTION:** Never change cutting head or service blades while machine is running.

 **WARNING:** Disarm machine when machine is not in use. Remove the cutting head or drop cutting head to the floor. Failure to do so could cause severe bodily injury.

Note: When removing carpet from over VCT Tile and the tile needs to be saved, run the machine at a 45° angle over the tile. This should help to save the tile.

Note: Run time will be depleted if machine is used on difficult removals such as ceramic & wood

2900HS BLADE APPLICATION/SET-UP

DITCHING

CROSS ROOM DITCHING

When removing hard to remove ceramic, Vct or vat, cross-room ditching will help to make the removal easier. Using a blade 2" to 6" in width, make ditches 1' to 2' apart in the same direction the machine will be removing the goods (Figure A). This "relieves" the pressure holding the tiles together. If ditching helps and the goods are coming up easy, try using a wider blade to ditch with.

CHECKER BOARD DITCHING

To make carpet removal and debris cleanup easier, checker board ditching is very helpful. Using as wide of a self-scoring blade as possible, make ditches 4' to 6' apart crossways from the way the machine will be removing the goods (Figure B). Running the machine crossways from the ditches will make smaller pieces of debris to be hauled away. Instead of large gummy rolls of carpet, there are small squares that can be rolled, palletized, put on a dolly or folded with the sticky side in. This makes removing the debris easier and reduces the amount of debris.

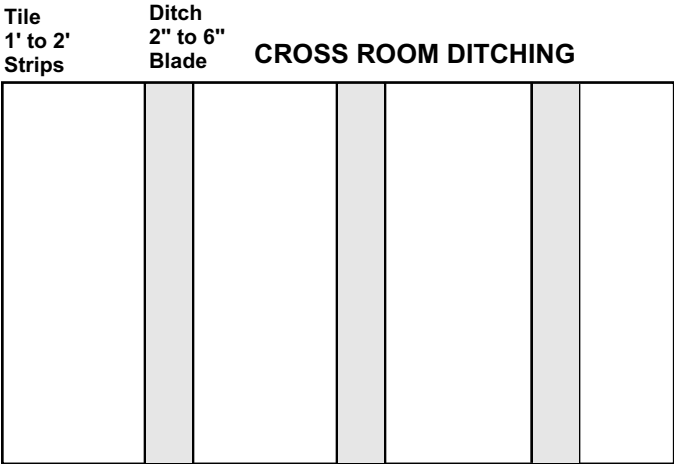

Figure A

↑ Run the machine the same direction that the ditches are made ↑

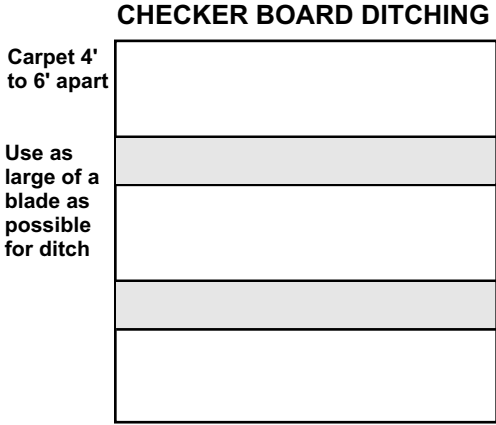

Figure B

↑ Run the machine crossways from the directions that the ditches are made ↑

2900HS BLADES

TYPES OF BLADES

PREMIUM HIGH TEMPERED BLADES (.062)

Works on all glued down carpets, VCT, VAT, rubber tile, cork, re-scraping adhesive, elastomeric coatings. Great for floor accumulations. Ultra high quality spring steel is extra hard for long blade life between sharpening.

HEAVY DUTY BLADES (.094)

Works on VCT, VAT, wood, tile, rubber epoxy, thin-set, elastomeric coatings, scraping, thin set and glued ceramic. A heavy-duty blade that still gives a little flex. Blade sharpening process helps these blades to stay sharper longer.

EXTRA HEAVY DUTY BLADES (.187 & .250)

Works on VCT, VAT, wood, tile, thin ceramic, re-scraping thin set, all carpets, cork, elastomeric coatings re-scraping rubber and urethane coatings. Extremely hard, high abrasion alloy for tough tear-up situations. Holds the edge extremely well.

SHOE BLADES/ANGLE SHANK BLADES (.500)

Works well for ceramic, wood, thick epoxy, thin-set, mud set, decorative concrete topping and much more. Blade is mounted at an angle to achieve the optimum shear point for optimum performance. Made from an ultra tough alloy, which is put through special processing to achieve an unbelievable edge holding ability.

SHOE BLADES/ANGLE SHANK BLADES WITH CARBIDE TIPS (.500)

Works well for ceramic, wood, thick epoxy and elastomeric coatings. Carbide tipped for holding a sharp edge for long periods. Nothing else performs like carbide when no other blade will work. Blade is mounted at an angle to achieve the optimum shear point for optimum performance. Made from an ultra tough alloy, which is put through special processing to achieve an unbelievable edge holding ability.

SELF-SCORING BLADES (.062 & .094)

Works on attached cushion, Unitary or secondary backing, vinyl back, soft to medium PVC, linoleum, carpet tiles, soft cork, Enhancer and Unibond hot melts. Instead of pre-scoring a job, the self-scoring blades have "wings" that automatically do the scoring. Blade hardening process makes these blades tough and long lasting.

RAZOR/SCRAPER BLADES (.032 & .045)

Used for re-scraping thin epoxies, thin mil coatings like; urethane paint, poured elastomeric coatings up to 60 mil, hard to remove adhesive and much more.

TILE BOX

Assists for a fast cleanup and collection of tile debris for quick removal. Can be used to remove easy to remove tile. Extremely high abrasion alloy for a long lasting edge. Edge can be re-sharpened.

2900HS BLADES

BLADE SHARPENING

Dull blades greatly reduce cutting ability. Re-sharpen or replace as needed. In use, blades develop a back-bevel (Figure A). When re-sharpening, blade will not be truly sharp until all back-bevel is gone.

Note: Thinner blades are easier to sharpen, but they also break easier.

- Always wear gloves and safety glasses.
- Grind blade using a 4" diameter disk with 120 or finer grit. Be careful not to catch disk on edge or corner of blade.
- Pass grinder back and forth along blade edge being careful to hold grinder at proper angle of blade. Grind until sharp.
- Using a good quality fine tooth hand file, use same procedure as above.
- Blades are sharp. Use extreme caution.
- Have plenty of sharp blades on each job so on-the-job blade sharpening is eliminated.
- It is best to resharpen dull blades on proper bench or belt grinder in the shop, so the blades are ready for the next job.

SELF-SCORING BLADE SHARPENING

It is important to keep the “wings” on a self-scoring blade sharp (Figure B). Use a file on the “wing” edge. Sharpen the flat part of the blade, the same way as described above.

CARBIDE TIPPED BLADE SHARPENING

To sharpen carbide tipped blades, a wheel to grind carbide is necessary, ie: green wheel or diamond wheel.

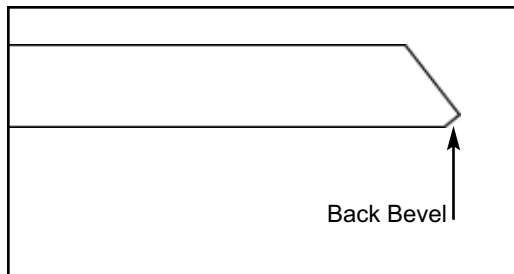

Figure A

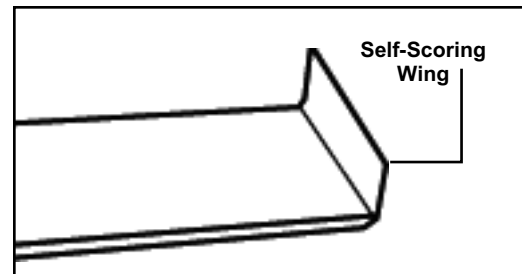



Figure B



CAUTION: Blades are sharp, use extreme caution. 



CAUTION: Never change cutting head or service blades while machine is running.



WARNING: Disarm machine when machine is not in use. Remove the cutting head or drop cutting head to the floor. Failure to do so could cause severe bodily injury.

2900HS BLADES

Part #	Description	Application	Thickness
#135	5" x 16" Blade	Rubber back carpet on wood or concrete floors, excellent for cleanup and longer durability	.062
#147	4" x 6" Blade	Tile or linoleum on concrete floors	.062
#148	5" x 6" Blade	Tile or linoleum on wood floors	.062
#363-2	3/4" x 8" Razor/Scraper Blade (50/pkg)	Razor sharp, super hard for scraping thin epoxies, thin mil coatings like; urethane paint, poured elastomeric coatings up to 60 mil, hard to remove adhesive and much more.	.032
#368-8	7/8" x 8" Razor/Scraper Blade (50/pkg)		.045
#368-12	7/8" x 12" Razor/Scraper Blade (50/pkg)		.045
#368-15	7/8" x 15" Razor/Scraper Blade (50/pkg)		.045
#6258-BU	3" x 12" Self-Scoring Blade - Bevel Up	Works on attached cushion, Unitary or secondary backing, vinyl backing, soft to medium Pvc, linoleum, carpet tiles, soft cork, Enhancer and Unibond hot melts.	.062
#6259-BU	3" x 14" Self-Scoring Blade - Bevel Up		.062
#6260-BD	3" x 6" Heavy Duty Ditching		.094
#6276-BU	3" x 10" Self-Scoring Blade	Same application as the .062 blade. The 45° angle, self-scoring wings for easy sharpening. The thickness greatly reduces breakage, especially on heavily weighted machines.	.094
#6277-BU	3" x 12" Self-Scoring Blade		.094
#6278-BU	3" x 14" Self-Scoring Blade		.094
#6281	3" x 8" Heavy Duty Blade	A heavy duty blade that still gives a little flex. Made with Nationals proven blade hardening process, these blades will stay sharper longer with better overall performance than any other blade on the market. Works on Vct, Vat, wood, tile, rubber epoxy, thin-set, elastomeric coatings, scraping thin-set, glued ceramic.	.094
#6282	3" x 14" Heavy Duty Blade		.094
#6283	3" x 27" Heavy Duty Blade		.094
#6284	3" x 12" Heavy Duty Blade		.094
#6285	3" x 6" Heavy Duty Blade		.094
#6286	3" x 10" Heavy Duty Blade		.094
#6290	3" x 6" Extra Heavy Duty Blade	Extremely hard, high abrasion alloy for tough tear-up situations. Vct, Vat, wood, tile, thin ceramic, re-scraping thin-set, all carpets, cork, elastomeric coatings, re-scraping rubber and urethane coatings. Holds the edge extremely well.	.187
#6291	3" x 8" Extra Heavy Duty Blade		.187
#6292	3" x 12" Extra Heavy Duty Blade		.187
#6293	3" x 14" Extra Heavy Duty Blade		.187
#6294	3" x 27" Extra Heavy Duty Blade		.187
#7050-200	3" x 6" Premium High Tempered Blade	Ultra high quality spring steel is extra hard for long blade life between sharpening. Works on all glue down carpets, Vct, Vat, rubber tile, cork, re-scraping adhesive, elastomeric coatings. Great for floor accumulations.	.062
#7050-201	3" x 8" Premium High Tempered Blade		.062
#7050-202	3" x 10" Premium High Tempered Blade		.062
#7050-203	3" x 12" Premium High Tempered Blade		.062
#7050-204	3" x 14" Premium High Tempered Blade		.062
#7050-205	3" x 27" Premium High Tempered Blade		.062
#7070-2	4" x 2" Straight Shank Blades	Works well for ceramic and thick epoxy. Made from an ultra tough alloy, which is put through special processing to give these blades unbelievable edge holding ability for ceramic, epoxy, thin-set, mud-set, decorative concrete toppings and much more.	.500
#7070-3	4" x 3" Straight Shank Blades		.500
#7070-4	4" x 4" Straight Shank Blades		.500
#7070-6	4" x 6" Straight Shank Blades	Works well for ceramic and thick epoxy. The same application as the #7070 Blades except mounted at an angle to achieve the optimum shear point for optimum performance.	.500
#7071-2	4" x 2" Angle Shank Blades		.500
#7071-3	4" x 3" Angle Shank Blades		.500
#7071-4	4" x 4" Angle Shank Blades		.500
#7071-6	4" x 6" Angle Shank Blades	Works well for ceramic and thick epoxy. The same application as the #7070, includes the angle like the #7071 and carbide tipped like the #7072. Works well on elastomeric coatings.	.500
#7072-2	4" x 2" Straight Shank w/Carbide Tip		.500
#7072-3	4" x 3" Straight Shank w/Carbide Tip		.500
#7072-4	4" x 4" Straight Shank w/Carbide Tip		.500
#7072-6	4" x 6" Straight Shank w/Carbide Tip		.500

2900HS BLADES

Part #	Description	Application	Thickness
#7074	5" x 27" Tile Box with 6" High Box	Extremely high abrasion alloy for a long lasting edge. Box assists for a fast clean-up and collection of tile debris for quick removal.	.187
#7075-8	2" x 8" Tapered Cutting Head Shank	The long taper works great on tough wood floors (glued & nailed). The long length allows the blade to easily slide under tough material. Works well on most ceramics and VCT.	.300
#7075-11	2" x 11" Tapered Cutting Head Shank		.300
#7077-8	3.5" x 8" Tapered Cutting Head Shank		.300
#7077-11	3.5" x 11" Tapered Cutting Head Shank		.300
#7076-8	2" x 8" Tapered w/Carbide Tip	The long taper works great on tough wood floors (glued & nailed). The long length allows the blade to easily slide under tough material. Works well on most ceramics and VCT. Carbide tipped for holding a sharp edge for long periods.	.300
#7076-11	2" x 11" Tapered w/Carbide Tip		.300
#7078-8	3.5" x 8" Tapered w/Carbide Tip		.300
#7078-11	3.5" x 11" Tapered w/Carbide Tip		.300
#7079-2	2" x 6" Ultra HD Ceramic Epoxy Blade	Designed for ceramic removal & thin-set re-scraping. 1/2" of carbide which is twice the carbide of the #7072 series blades. The extra carbide allows for maximum re-sharpening. Strong enough to work on machines up to 3500 lbs.	.500
#7079-4	4" x 6" Ultra HD Ceramic Epoxy Blade		.500
#7079-6	6" x 6" Ultra HD Ceramic Epoxy Blade		.500
#7081	3" x 10" Increased Angle Blade	Mainly used for VCT but can be used on most other applications. Supplies more of an angle when needed. Prevents machine from jumping off material.	.062
#7083	3" x 3" Increased Angle Blade		.062

2900HS MACHINE MAINTENANCE

SLIDE PLATE

To Remove Slide Plate

1. Disconnect machine from power.
2. Remove slide plate pin. Remove cutting head bolt. Remove cylinder from slide plate. Remove slide plate.

OR

1. Disconnect machine from power.
2. Unplug hydraulic lines from cylinder. A small amount of oil leak out of lines. Cap lines or bleed into a container. Wipe up spillage immediately.
3. With lines removed, loosen slide plate securing bolts. Hold slide plate at the top of the cylinder. Take Caution: slide plate will drop to the floor when slide plate securing bolts are disengaged. Keep hands and feet out from underneath slide plate.
4. Remove slide plate, cylinder and lower cutting head support.

Take Caution: slide plate will drop to the floor when slide plate securing bolts are disengaged. Keep hands and feet out from underneath slide plate, failure to do so could cause severe bodily injury.

RAISING OR LOWERING THE SLIDE PLATE

This will only work without a cutting head inserted in the machine. Completely loosen slide plate bolts. Use cylinder lift lever to raise or lower machine to move slide plate up or down.

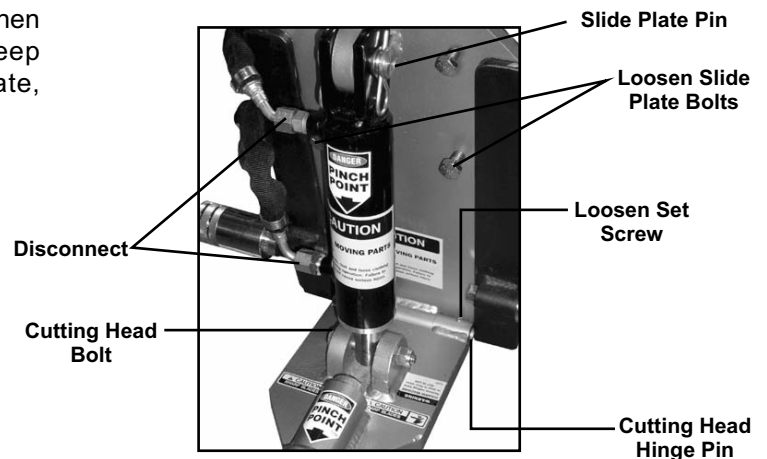

LOWER CUTTING HEAD SUPPORT

To Remove Lower Cutting Head Support

1. Lower slide plate so cutting head hinge pin is below machine bottom. Retighten.
2. Loosen both cutting head pin set screws at the base of the lower cutting head support (hinge area).
3. Drive cutting head pin out using a punch and hammer.
4. Remove cylinder securing hex head bolt.

LEAK MAINTENANCE

All fittings on this machine are O-ring style.

1. Disconnect machine from power.
2. If a leak is detected, tighten fitting with the proper wrench size. DO NOT over tighten. Over tightening could damage O-rings.
3. If a leak still persists, remove fitting and replace O-ring.

2900HS MACHINE MAINTENANCE

OIL LEVEL

To Check Oil Level

1. Remove Filler plug (Figure A).
2. Oil should be visual 2" below hole.
3. Reinsert plug.

OIL CHANGE OUT

1. Disconnect machine from power (charger or battery).
2. Drain fluid by removing the drain plug from side of tank (Figure B). **Take Caution:** this unit contains seven gallons of fluid. Make sure you have the proper amount of containers to catch fluid.
3. Replace drain plug.
4. Remove filler plug (Figure A).
5. Add oil into the filler plug hole until visual 2" below hole.

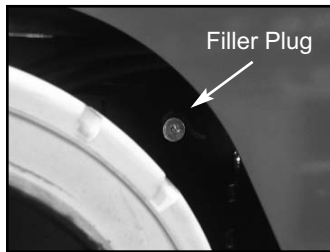

Figure A

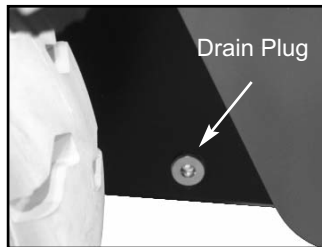

Figure B

WHEEL MOTOR CHANGE OUT

1. Disconnect machine from power.
2. Block up machine to remove wheel. See wheel changing on page 42.
3. Remove wheel.
4. Remove oil lines from wheel motor. A small amount of oil will run out of the lines. Drain into a container. Wipe up spills immediately.
5. Remove four 1/2" wheel motor securing nuts.
6. Pull out on wheel motor to remove.

2900HS MACHINE MAINTENANCE

HOSE CHANGE OUT

To Remove or Change a Hose

1. Disconnect machine from power.
2. Remove hood.
3. Using proper wrench size, remove hose from fitting.
4. When replacing, make sure O-ring is properly seated on hose fitting.

FOOT PEG

To Remove or Replace Foot Peg

1. Insert a socket wrench into foot peg and secure bolt head.
2. Remove nut and washer.
3. Remove bolt and foot peg.
4. Replace foot peg before operating machine. DO NOT use machine without foot pegs.

PUMP CHANGE OUT

1. Remove doghouse to expose pump.
2. Disconnect hydraulic lines.
3. Remove two 5/16" pump securing bolts.
4. Remove pump by pulling pump straight out from pump motor.

VALVE CHANGE OUT

1. Disconnect machine from power (charger or battery).
2. Lift hood and secure in place.
3. Remove hoses from valve body. have a container ready to catch leakage from lines.
4. Take notice of angle of valve fittings.
5. Remove two 1/4" bolts securing valve body.

MOTOR CHANGE OUT

1. Disconnect motor from power.
2. Lift hood and secure in place.
3. Remove pump (see pump change out).
4. Loosen the bracket holding the motor.
5. Remove motor.

2900HS MACHINE MAINTENANCE

HYDRAULIC CYLINDER CHANGE OUT

1. Disconnect machine from power.
2. Disconnect cylinder lines. Have a container ready to catch oil from lines.
3. Remove cylinder securing hexhead bolt from lower cutting head support.
4. Remove clips and pin from cylinder and slide plate.
5. Remove cylinder upper pin.
6. Remove cylinder.

WHEEL CHANGING

1. Jack machine up by pushing the cylinder lift forward to lower and adjust the angle of the cutting head to raise machine.
2. Place blocks under Forklift Cups on the side of the machine that wheel is being changed. **Take Caution:** Make sure machine is supported properly or serious injury could occur.
3. Let cylinder down resting machine on blocks allowing rear wheel to be lifted off the floor.
4. Remove five 1/2" lug nuts with an extended arm wrench, remove wheel.
5. Replace wheel.
6. Replace five lug nuts and tighten, making sure lug nuts are very tight.
7. Raise cylinder to raise machine off of blocks. Remove blocks and lower machine.
8. Repeat to other side if necessary.



CHANGING FILTER- Filter should be replaced yearly.

OLD STYLE

1. Remove the three filter cover bolts (Figure A).
2. Lift out the filter (Figure B).
3. Replace with new filter.
4. Replace cover spring.
5. Replace and firmly tighten bolts.

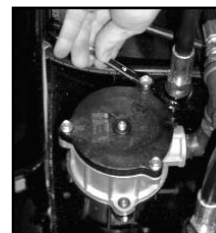

Figure A

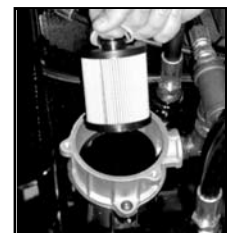

Figure B

NEW STYLE (Figure C)

1. Remove old filter by turning counter-clockwise
2. Install new filter by turning clockwise



Figure C

2900HS MACHINE MAINTENANCE

CASTER MAINTENANCE

1. Keep clean and free of debris, make sure it can move freely.
2. Give a shot of grease in grease zerc on caster every six months to keep moving freely.
3. To remove caster, machine will need to be raised. Push the cylinder lift lever forward to lower and adjust the angle of the cutting head to jack up the machine (Figure C). Block up machine (Figure D). Remove four bolts, pull caster off, clean/replace as needed.
4. Replace caster.
5. Replace and firmly tighten the four bolts.
6. Lower the machine.

*Note: A spacer is needed with caster when using an 18 inch wheel.



Figure C

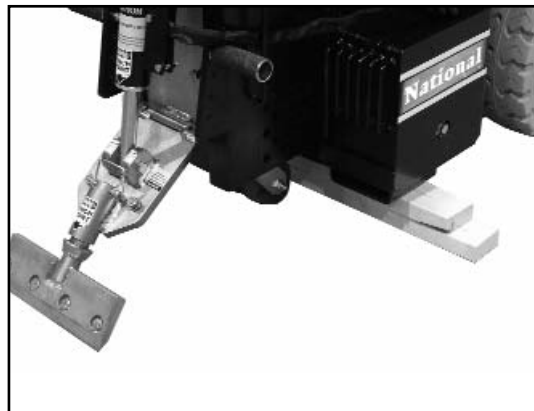

Figure D

⚠ WARNING: Do Not alter a switch or lever. Do Not defeat a safety device.

⚠ WARNING: The Back Up Beeper is on the machine for safety. It is important to keep it in good working condition. Failure to do so could cause bodily injury.

2900HS MACHINE MAINTENANCE

SEAT REPLACEMENT

1. Remove four (4) button hexhead screws on each side of the hood (4 times).
2. Slightly raise seat plate & unplug wire harness.
3. Lift hood off.
4. Remove seat.
5. To replace seat, set seat on top of hood.
6. Replace the four 5/16 button hexhead screws from underneath the hood.
7. Firmly tighten.
8. Reconnect back-up beeper and seat switch wires.
9. Replace hood and screws.

⚠ WARNING: Always disconnect from battery before maintaining.



⚠ WARNING: Never operate machine without pump guard housing in place.

SWITCHES

There are three switches:

1. On (Start) Switch
2. Off (E-Stop) Switch
3. Seat Switch

5200-258

DEBRIS DEFLECTOR MOUNTING INSTRUCTIONS

•Insert and secure a cutting head, making sure cutting head is **all the way in**.

•**If there are holes on your lower cutting head support**, place debris deflector under the lower cutting head support and bolt in place.

•**If there are not holes on the lower cutting head support**, place debris deflector on the lower cutting head support, measuring a 1" clearance between the cutting head and the front of the debris deflector. This clearance will reduce a "pinch point".

•Secure with C-clamps.

•Mark the holes from the debris deflector on the lower cutting head support.

•Either drill a 1/2" hole on each mark and secure debris deflector with a bolt and lock nut **OR** drill a 27/64" hole and tap 1/2-13.

•Firmly secure debris deflector under the cutting head.

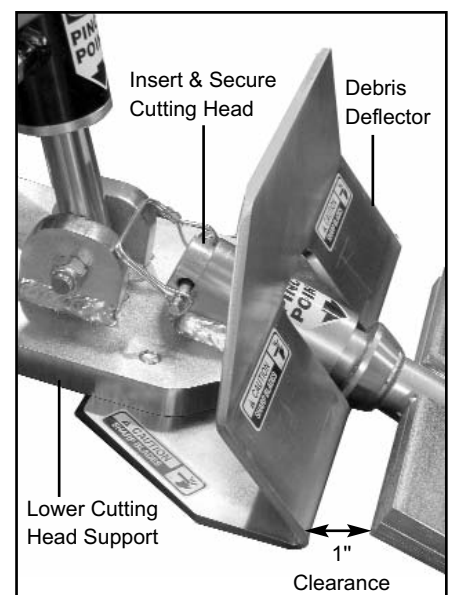

Note: Number in parenthesis () is the amount needed on each machine. Parts are sold individually therefore order the number of parts needed.

2900HS COMPLETE PARTS LIST

PARTS LIST

<u>PART #</u>	<u>DESCRIPTION</u>
5110-100	FRONT WHEEL ASSEMBLY
5110-111	SEAT
5110-114	HYDRAULIC WHEEL MOTOR (OLD STYLE) (2) (NOT SHOWN)
5110-114A	HIGH SPEED HYDRAULIC WHEEL MOTOR (2)
5110-114-2	WHEEL MOTOR FITTING (4)
5110-114-5	WHEEL MOTOR SET OF SEALS (OLD STYLE) (NOT SHOWN)
5110-114-5A	WHEEL MOTOR SET OF SEALS (NEW STYLE) (NOT SHOWN)
5110-115	SINGLE SPOOL CONTROL
5110-116	DOUBLE SPOOL CONTROL
5110-117	WHEEL HUB (2)
5110-117-2	HUB NUT (2)
5110-164A	RETURN TANK HOSE
5110-164B	RETURN TANK HOSE CLAMP
5110-166	SLIDE PLATE
5110-167	LOWER CUTTING HEAD SUPPORT
5110-170	CUTTING HEAD PIN
5110-180	FOOT PEG (2)
5110-207	SEAT SWITCH
5110-218	BACK-UP BEEPER SWITCH
5110-219	STRAIGHT VALVE BODY PLUG (8)
5110-233	BREATHER ASSEMBLY
5110-234	RELIEF VALVE COUPLER (ONLY)
5110-234-1	RELIEF VALVE NIPPLE (ONLY)
5110-235-1	FILTER HOSE FITTING ONLY (OLD STYLE) (2)
5110-235-2	FILTER "T" ONLY (OLD STYLE)
5110-235-3	FILTER COUPLER ONLY(OLD STYLE)
5110-236-1	REPLACEMENT FILTER RETURN
5110-237	SUCTION FILTER SCREEN
5110-237-1	FILTER SUCTION LINE ASSEMBLY (2)
5110-237-1A	SUCTION FILTER HOSE (ONLY) (2) (NOT SHOWN)
5110-237-1B	FILTER HOSE FITTINGS (ONLY) (4)
5110-250	CYLINDER
5110-250-3	CYLINDER SEAL KIT REPLACEMENT
5110-251	CYLINDER CONNECTING ROD
5110-252	CYLINDER CLIP (2)
5110-267	CYLINDER LINE HOSES
5110-268	STRAIGHT VALVE FITTING (2)
5110-271	LEVER BRACKET
5110-272	CYLINDER LIFT LEVER
5110-404	REAR WEIGHT
5110-405	18" WHEEL RIM & TIRE (2)

2900HS COMPLETE PARTS LIST

PARTS LIST (continued)

<u>PART #</u>	<u>DESCRIPTION</u>
5200-1G	DOUBLE PUMP GASKET
5200QL-11-LH	SINGLE SPOOL MOUNT
5200QL-11-RH	DOUBLE SPOOL MOUNT
5200-18	CLAMP FRONT MOTOR (2)
5200-28	SIDE SUPPORT ROD (2)
5200-30	BASE ASSEMBLY (DOG HOUSE)
5200-116	BACK-UP BEEPER ASSEMBLY
5200-118-1	ELECTRICAL BOX SHELL - USE 5200-118 ELEC BOX ASSEMBLY? SAGE SAYS 5110-118-1 ELEC. BOX COVER ONLY
5200-118-8	BLUE 48V BATTERY CHARGER CONNECTOR (3)
5200-118-9	48V BATTERY CONNECTOR (2)
5200-127	ELECTRICAL STRIP
5200-157	DRAIN/FILLER PLUG (3)
5200-194	DOUBLE WHEEL CASTER ASSEMBLY (GREY)
5200-194A	REPLACEMENT WHEEL ONLY (2) (NOT SHOWN)
5200-258	DEBRIS DEFLECTOR
5200-261	WHEEL MOTOR LINE (4)
5200-261-1	WHEEL MOTOR HOSE CLAMP ASSEMBLY (2)
5200-261-1A	CLAMP COVER (ONLY) (2)
5200-261-1B	CLAMP BODY (ONLY) (4)
5200-263	SUCTION LINE (2)
5200-266	RETURN LINE (2)
5200-400-2	FRONT WEIGHT (36# EACH) (6)
5200-603	HOSE GUIDE
5200QL-1	5 HP MOTOR
5200QL-1A	MOTOR PLATE
5200QL-13	VALVE LEVER SPACER
5200QL-14	BACKUP BEEPER PIN ASSEMBLY
5200QL-27	MAIN BASE (NOT SHOWN)
5200QL-30	HOOD LEVER ASSEMBLY
5200QL-31	HOOD LEVER ONLY
5200QL-32	HOOD LEVER BRACKET (ONLY)
5200QL-34	REVERSE CATCH

2900HS COMPLETE PARTS LIST

PARTS LIST (continued)

<u>PART #</u>	<u>DESCRIPTION</u>
5200QL-236	FILTER HOUSING ASSMY (OLD STYLE)
5200QL-236A	FILTER HOUSING GASKET (OLD STYLE)
5213-2	8 VOLT BATTERY, (6)
5215	BATTERY CHARGER-ON BOARD, 48V 115V
5600-21	HANDLE WEDLMENT - LEFT
5600-22	HANDLE WELDMENT - RIGHT
5600-58	VALVE LEVER SHORT
5700-36	HOSE GUARD (2)
5700-52	90° VALVE FITTING (2)
5700-54	HAND GRIP SLEEVE (2)
5700-57	FILTER BLOCK
5700-64	FILTER FITTING
5700-65	FILTER
5700-66	HEAD
5700-67	TANK PLUG
5700-70	T-FITTING
5700-71	HOSE (RETURN, RIGHT)
5700-72	HOSE (RETURN, LEFT)
5700-75	HOSE (PRESSURE, LEFT-12.5)
5700-81	SUCTION LINE
5700-90	RELAY SOCKETS
5700-91	SPECIALTY VOLTAGE RELAYS
5700-102	E-STOP SWITCH ASSEMBLY
5700-102D	NAME PLATE/EMERGENCY STOP
5700-103	START SWITCH ASSEMBLY
5700-104	CONTACTOR
5700-105	BATTERY FUEL GAUGE
5700-106	70 AMP CIRCUIT BREAKER
6280-1	OIL, GALLON (7)
6280-162G	TANK MAGNET (NOT SHOWN)

2900HS COMPLETE PARTS LIST

PARTS LIST (continued)

<u>PART #</u>	<u>DESCRIPTION</u>
70602	INSTRUCTION MANUAL TUBE
70603	INSTRUCTION TUBE CAP
70613	OIL FILTER BRACKET
70651	VALVE BODY PLUG (10)
70905-D5	MARZOCCHI DOUBLE PUMP #5
71701	BATTERY POST (9)
71702	BATTERY POST PROTECTOR (7)
72385	MOTOR, 4 HP
72451	NORMALLY OPEN CONTACTS
72452	NORMALLY CLOSED CONTACTS
72453	E-STOP OPERATOR/METAL
72454	GREEN FLUSH
72456	BODY MOUNTING COLLAR (2)
72705	50 AMP 48 VOLT CHARGER CONNECTOR ONLY
72801	1/4" 90° FITTING (2)
72816	3/8" 90 DEGREE ELBOW (2)
73005	1/4-20 X 1/2 HEXHEAD BOLT (3)
73006	1/4-20 X 3/4 BUTTON HEAD SOCKET CAP SCREW (4)
73007	1/4 FLAT WASHER (3)
73008	1/4-20 NYLON LOCK NUT (4 - VALVE BODY, 4 - HOOD LEVER)
73014	1/4-20 X 1½ HEXHEAD BOLT
73021	1/4-20 X 2¼ HEX HEAD CAP SCREW (4)
73023	1/4-20 X 2 HEX HEAD CAP SCREW
73025	1/4 BUTTON HEAD RIVET (3)
73029	1/4-20 X 3/4 FLAT HEAD SOCKET CAP SCREW (6)
73033	1/4 X 1/4 X 1 KEY
73047	1/4 X 1 WOODRUFF KEY (2)
73066	1/4-20 X 1¾ CLAMP BOLT (2)
73131	3/32 X 1¾ KOTTER PIN (2)
73201	3/8-16 X 1 HEX HEAD CAP SCREW, GR. 5 (3 - REAR COVER, 2 - MOTOR)
73202	3/8 INTERNAL LOCK WASHER (16 - BODY PANELS)(NOT SHOWN?)
73203	3/8 SAE FLAT WASHER (2 - FOOT PEGS, 5 - REAR COVER - PER JAY) (2 - GEAR PUMP-PER PAGES)
73204	3/8 SPLIT LOCK WASHER (2 - MOTOR PARTS, 2 - GEAR PUMP, 2 - FOOT PEG)
73207	3/8-16 NYLON LOCK NUT (2 - FOOT PEG, 2 - REAR COVER, 2 - VALVE BRACKETS-NOT SHOWN?)
73208	3/8-16 X 1½ HEXHEAD CAP SCREW (2 - FOOT PEG)
73213	3/8-16 X 3/4 BUTTON HEAD SOCKET CAP SCREW (8)(3 - CONTROL LEVER PARTS, NEW STYLE)
73214	3/8-16 X 1 BUTTON HEAD SOCKET CAP SCREW (2 - GEAR PUMP) (BOM SHOWS 2 & 4)
73248	5/16-18 X 1/4 CUP POINT SOCKET SET SCREW (2 - SLIDE PATE)
73270	3/8 X 3 LOCK PIN
73302	5/16 FLAT WASHER (4)
73303	1/4 X 1/4 X 1 KEY (2)
73322	5/16-18 NYLON LOCK NUT (3 - CYLINDER HOSE)
73324	5/16-18 X 3/4 SOCKET HEAD CAP SCREW
73333	5/16-18 X 1½ SOCKET HEAD CAP SCREW (3 - CYLINDER HOSE)
73403	1/2 SPLIT LOCK WASHER
73414	1/2-13 X 7 HEX HEAD BOLT
73424	1/2 FLAT WASHER, SAE ZINC

2900HS COMPLETE PARTS LIST

PARTS LIST (continued)

<u>PART #</u>	<u>DESCRIPTION</u>
73305	5/16-18X3/4 HEXHEAD CAP SCREW (4)
73308	5/16-18 X 3/4 BUTTON HEAD SOCKET CAP SCREW (2)
73402	1/2-13 NYLON LOCK NUT (1- CYLINDER, 4- CASTER)
73403	1/2 SPLIT LOCK WASHER (2 - SLIDE PLATE)
73404	1/2 FLAT WASHER SAE (2)
73406	1/2-13 X 1 1/4 HEXHEAD BOLT (5 - CASTER, 1 - WEIGHTS) (BOM SHOWS 2, 4, & 1)
73407	1/2-13 X 1 1/2 HEX HEAD CAP SCREW (2)
73408	1/2-13 X 1 HEXHEAD CAP SCREW (2 - SLIDE PLATE)
73410	1/2-13 X 3 1/2 HEX HEAD CAP SCREW(CYLINDER)
73414	1/2-13 X 7 HEX HEAD BOLT (2) (NOT SHOWN?)
73419	1/2-13 X 1 1/2 HEXHEAD BOLT - GRADE 8 (6 - SLIDE PLATE)
73420	1/2-13 FULL HEX NUT (2)
73430	1/2-20 NYLON LOCK NUT (10 - WHEEL PARTS)
73505	3/8" STRAIGHT STRAIN RELIEF .315-.445
73507	12/3 6FT EXTENSION CORD
74425	10/32 K-LOCK NUT (2)
74433	10-32 X 1/2 PHILLIPS PAN HEAD SCREW (2)
74501	#6 FLAT WASHER SAE (2)
74510	6-32 X 3/8 PHILLIPS PAN HEAD MACHINE SCREW (2)
74513	6-32 X 3/4 PHILLIPS PANHEAD MACHINE SCREW (2)

2900HS COMPLETE PARTS LIST

BLADES & CUTTING HEADS

<u>PART #</u>	<u>DESCRIPTION</u>
135	5" X 16" BLADE
147	4" X 6" BLADE
148	5" X 6" BLADE
363-2	3/4" X 8" RAZOR/SCRAPER BLADE (50/PKG)
368-8	7/8" X 8" RAZOR/SCRAPER BLADE (50/PKG)
368-12	7/8" X 12" RAZOR/SCRAPER BLADE (50/PKG)
368-15	7/8" X 15" RAZOR/SCRAPER BLADE (50/PKG)
6258-BU	3" X 12" SELF-SCORING BLADE - BEVEL UP
6259-BU	3" X 14" SELF-SCORING BLADE - BEVEL UP
6260-BD	3" X 6" HEAVY DUTY DITCHING
6276-BU	3" X 10" SELF SCORING BLADE
6277-BU	3" X 12" SELF SCORING BLADE
6278-BU	3" X 14" SELF SCORING BLADE
6281	3" X 8" HEAVY DUTY BLADE
6282	3" X 14" HEAVY DUTY BLADE
6283	3" X 27" HEAVY DUTY BLADE
6284	3" X 12" HEAVY DUTY BLADE
6285	3" X 6" HEAVY DUTY BLADE
6286	3" X 10" HEAVY DUTY BLADE
6290	3" X 6" EXTRA HEAVY DUTY BLADE
6291	3" X 8" EXTRA HEAVY DUTY BLADE
6292	3" X 12" EXTRA HEAVY DUTY BLADE
6293	3" X 14" EXTRA HEAVY DUTY BLADE
6294	3" X 27" EXTRA HEAVY DUTY BLADE
7050-6	6" CUTTING HEAD
7050-8	8" CUTTING HEAD
7050-8RBH	8" RAZOR BLADE HEAD
7050-10	10" CUTTING HEAD
7050-12	12" CUTTING HEAD
7050-12RBH	12" RAZOR BLADE HEAD
7050-14	14" CUTTING HEAD
7050-14RBH	14" RAZOR BLADE HEAD
7050-27	27" CUTTING HEAD
7050-200	3" X 6" PREMIUM HIGH TEMPERED BLADE
7050-201	3" X 8" PREMIUM HIGH TEMPERED BLADE
7050-202	3" X 10" PREMIUM HIGH TEMPERED BLADE
7050-203	3" X 12" PREMIUM HIGH TEMPERED BLADE
7050-204	3" X 14" PREMIUM HIGH TEMPERED BLADE
7050-205	3" X 27" PREMIUM HIGH TEMPERED BLADE
7070-2	4" X 2" STRAIGHT SHANK BLADE
7070-3	4" X 3" STRAIGHT SHANK BLADE
7070-4	4" X 4" STRAIGHT SHANK BLADE
7070-6	4" X 6" STRAIGHT SHANK BLADE
7071-2	4" X 2" ANGLE SHANK/SHOE BLADE
7071-3	4" X 3" ANGLE SHANK/SHOE BLADE
7071-4	4" X 4" ANGLE SHANK/SHOE BLADE
7071-6	4" X 6" ANGLE SHANK/SHOE BLADE
7072-2	4" X 2" STRAIGHT SHANK BLADE W/CARBIDE TIP
7072-3	4" X 3" STRAIGHT SHANK BLADE W/CARBIDE TIP
7072-4	4" X 4" STRAIGHT SHANK BLADE W/CARBIDE TIP
7072-6	4" X 6" STRAIGHT SHANK BLADE W/CARBIDE TIP

2900HS COMPLETE PARTS LIST

BLADES & CUTTING HEADS (continued)

<u>PART #</u>	<u>DESCRIPTION</u>
7074	5" X 27" TILE BOX WITH 6" HIGH BOX
7075-8	2" X 8" TAPERED CUTTING HEAD SHANK
7075-11	2" X 11" TAPERED CUTTING HEAD SHANK
7076-8	2" X 8" TAPERED CUTTING HEAD SHANK W/CARBIDE TIP
7076-11	2" X 11" TAPERED CUTTING HEAD SHANK W/CARBIDE TIP
7077-8	3.5" X 8" TAPERED CUTTING HEAD SHANK
7077-11	3.5" X 11" TAPERED CUTTING HEAD SHANK
7078-8	3.5" X 8" TAPERED CUTTING HEAD SHANK W/CARBIDE TIP
7078-11	3.5" X 11" TAPERED CUTTING HEAD SHANK W/CARBIDE TIP
7079-2	2" X 6" EXTRA HD CERAMIC EPOXY SHANK W/ CARBIDE TIP
7079-4	4" X 6" EXTRA HD CERAMIC EPOXY SHANK W/ CARBIDE TIP
7079-6	6" X 6" EXTRA HD CERAMIC EPOXY SHANK W/ CARBIDE TIP
7081	3" X 10" INCREASED ANGLE BLADE
7083	3" X 8" INCREASED ANGLE BLADE
73330	5/16 X 2 LOCK PIN

LABELS

<u>PART #</u>	<u>DESCRIPTION</u>
L08-1	STAND CLEAR LABEL (2)
L33B	CAUTION MOVING PARTS LABEL (2)
L33C	INSTRUCTION MANUAL LABEL
L33D	AUTHORIZED PERSONNEL LABEL
L37	CAUTION SHARP BLADES (2)
L38	DISCONNECT BEFORE SERVICING LABEL (NOT SHOWN)
L66	LARGE CAUTION LABEL
L95F	FLUID LEAK LABEL (2)
L98	BLADE LIFT LABEL
L101	KILL SWITCH LABEL
L106	PINCH POINT LABEL (3)
L118	OPERATOR MUST BE SEATED LABEL (2)
L127	CAUTION OPERATING TEMP LABEL
L137	DISARM MACHINE LABEL (3)
L141	FLAG LABEL/ MADE IN USA (2)
L142	TRAILER HITCH LABEL
L148	GENERAL INFO LABEL
L151	PANTHER HEAD LABEL (2)
L155	GENERAL WARNING LABEL
L159	5200 BATTERY CONNECT LABEL +/-
L161	5200 BATTERY SERIES +/-
L162	48 VOLT VDC LABEL
L165	LARGE RIDE-ON LABEL - WILL THIS BE THE NEW L164?
L175	NATIONAL LABEL, SMALL
L176	NATIONAL LABEL, LARGE (2)
L223	PATENT NUMBER LABEL
L304	METAL SERIAL NUMBER PLATE (NOT SHOWN)
L305	DO NOT GET CHARGER WET LABEL (3)
L307	2900HS STOCK NUMBER LABEL (2)
L311	BATTERY LABEL(6)

2900HS COMPLETE PARTS LIST

ACCESSORIES

<u>PART #</u>	<u>DESCRIPTION</u>
1009	SAFETY GLASSES
5110-100	FRONT WHEEL ASSEMBLY
5110-100W	REPLACEMENT WHEEL ONLY
5110-111-3	OPTIONAL ARM REST/SET - LEFT & RIGHT ARMREST W/ MOUNTING HARDWARE INCLUDED
7050-15	CUTTING HEAD EXTENSION
7074	TILE BOX

2900HS PART NUMBERS & DIAGRAMS

EXTERNAL PARTS

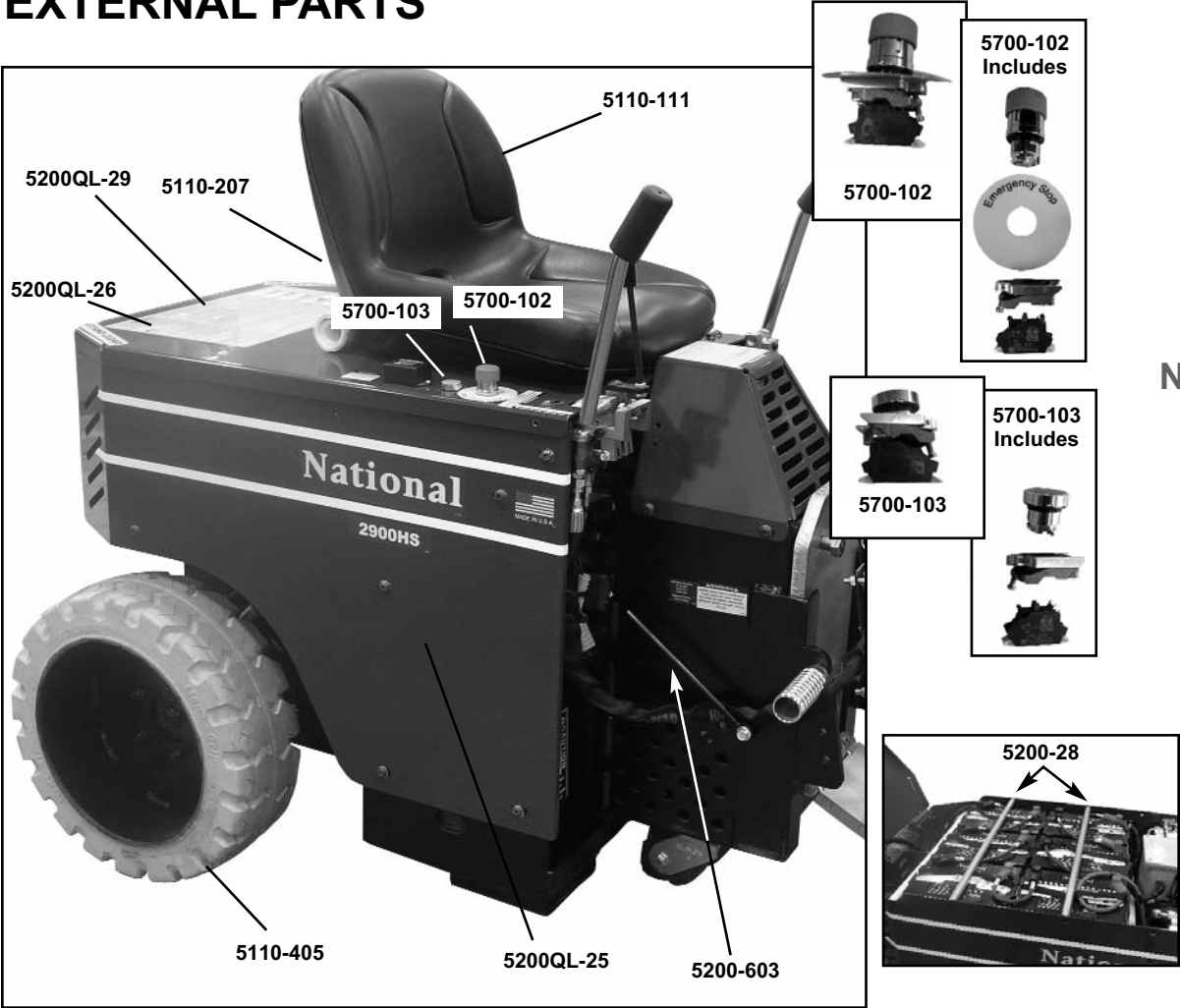

NEED NEW PIC

<u>PART #</u>	<u>DESCRIPTION</u>	<u>PART #</u>	<u>DESCRIPTION</u>
5110-111	Seat	5200QL-27	Main Base (Not Shown)
5110-405	18" Wheel Rim & Tire (2)	5200QL-28	Battery Hinged Cover - need new pic
5700-102	E-Stop Switch Assembly	5200QL-29	Seat Plate
5700-103	Start Switch Assembly	5200-28	Side Support Rod (2)
5110-207	Seat Switch (Not Shown)	5200-603	Hose Guide
5200QL-25	Right Side Panel		
5200QL-26	Left Side Panel (Not Shown)		

2900HS PART NUMBERS & DIAGRAMS

EXTERNAL PARTS

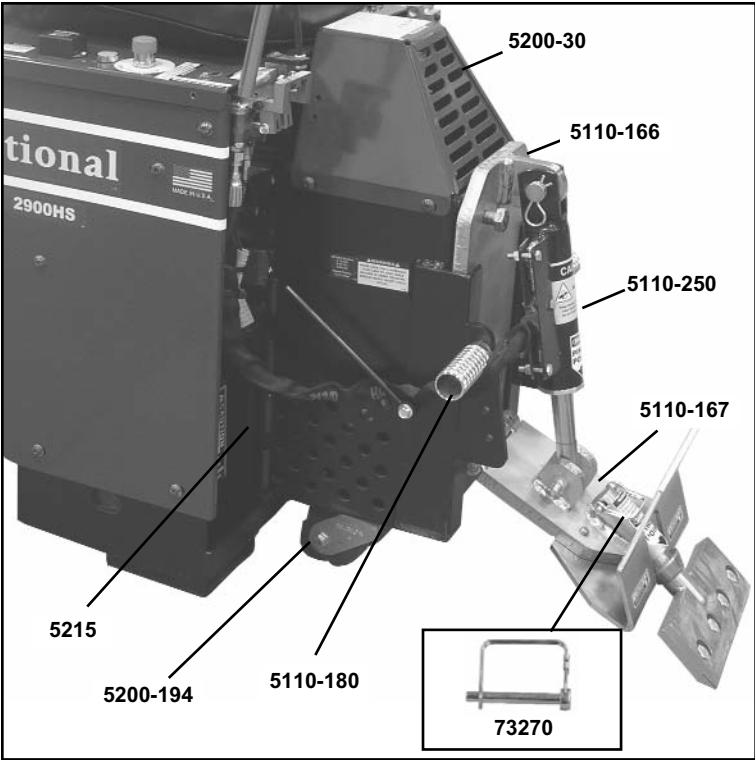

<u>PART #</u>	<u>DESCRIPTION</u>
5110-166	Slide Plate
5110-167	Lower Cutting Head Support
5110-180	Foot Peg (2)
5110-250	Cylinder
5200-30	Base Assembly (Dog House)
5200-194	Double Wheel Caster Assembly (Grey)
5215	Battery Charger - On Board 48V 115V
73270	3/8 x 3 Lock Pin

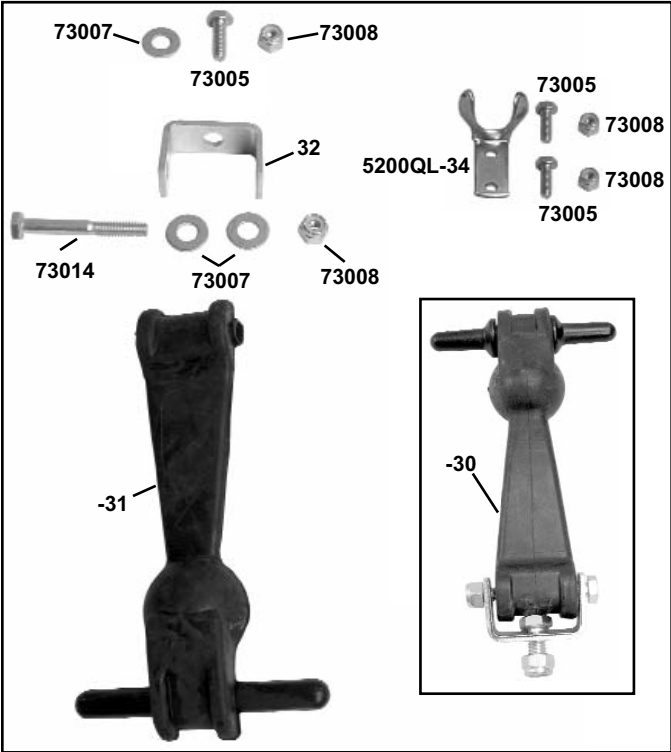

<u>PART #</u>	<u>DESCRIPTION</u>
5200QL-30	Hood Lever Assembly
5200QL-31	Hood Lever Only
5200QL-32	Hood Lever Bracket Only
5200QL-34	Reverse Catch
73005	1/4-20 x 1/2 Hexhead Bolt (3)
73007	1/4 Flat Washer (3)
73008	1/4-20 Nylon Lock Nut (4)
73014	1/4-20 x 1-1/2 Hexhead Bolt
73025	1/4 Button Head Rivet (3)

2900HS PART NUMBERS & DIAGRAMS

BEEPER & HOOD PARTS

BACKUP BEEPER ASSEMBLY



PART #
5200-116

DESCRIPTION
Back-Up Beeper Assembly

HANDLE SWITCH (FOR BEEPER)



PART #
5110-218
74513

DESCRIPTION
Back-Up Beeper Switch
6-32 x 3/4 Phillips Panhead
Machine Screw (2)

INSTRUCTION TUBE PARTS

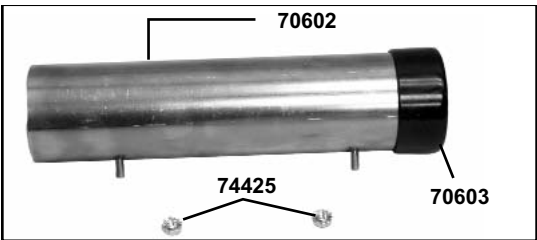

PART #
70602
70603
74425

DESCRIPTION
Instruction Manual Tube
Instruction Tube Cap
10/32 K-Lock Nut (2)

2900HS PART NUMBERS & DIAGRAMS

ELECTRIC BOX & BATTERY CONNECTOR PARTS

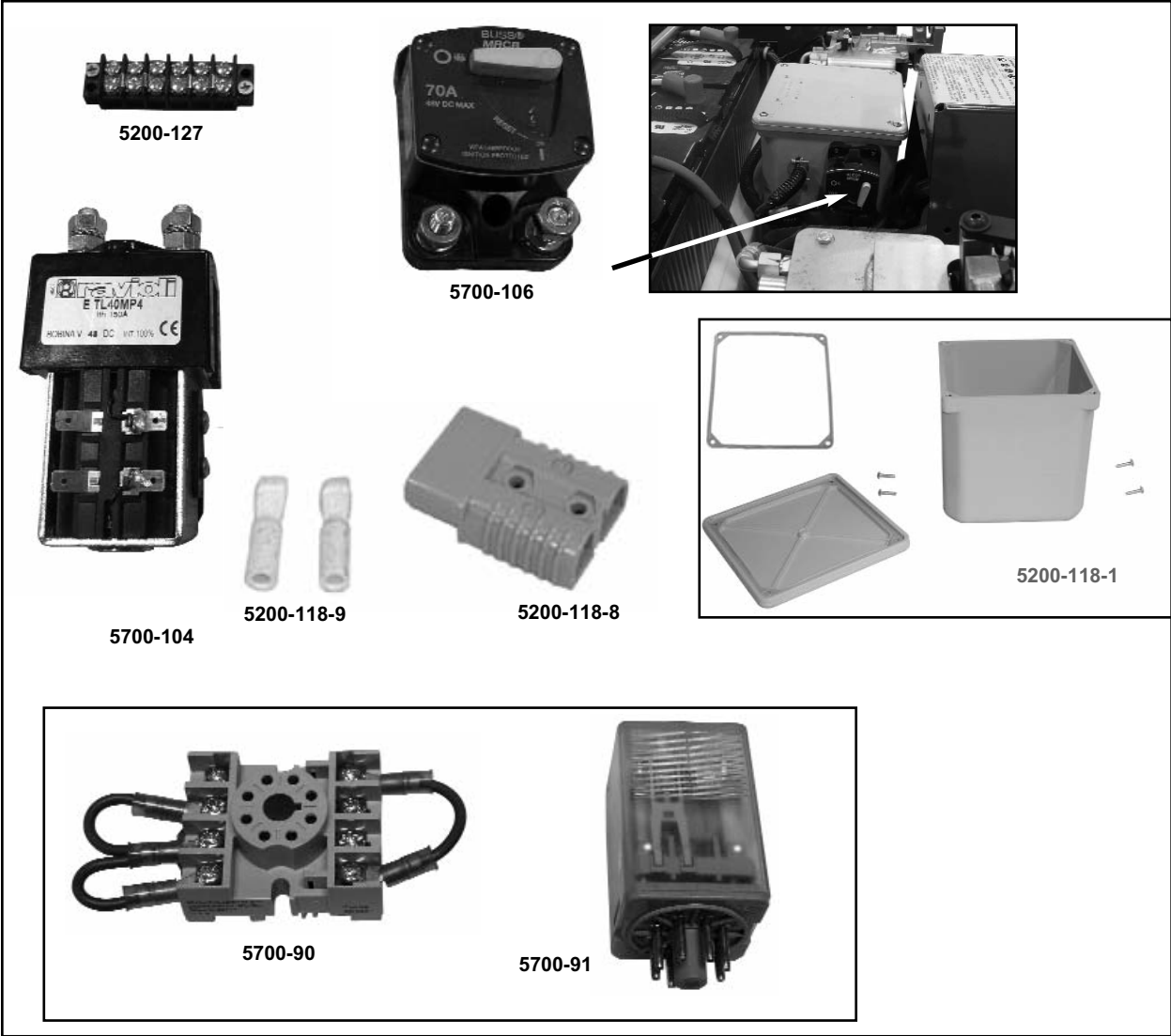

<u>PART #</u>	<u>DESCRIPTION</u>	<u>PART #</u>	<u>DESCRIPTION</u>
5200-118-1	Electrical Box Shell Only	5700-90	Relay Sockets
5200-118-8	Blue 48V Battery Charger	5700-91	Specialty Voltage Relays
5200-118-9	48V Battery Connector (2)	5700-104	Contactors
5200-127	Electrical Strip	5700-106	70 Amp Circuit Breaker

2900HS PART NUMBERS & DIAGRAMS

MOTOR



<u>PART #</u>	<u>DESCRIPTION</u>
5200-18	Clamp Front Motor (2)
5200QL-1	5 HP Motor
5200QL-1A	Motor Plate

<u>PART #</u>	<u>DESCRIPTION</u>
73201	3/8-16 x 1 Hexhead Cap Screw, Gr. 5 (2)
73204	3/8 Split Lock Washer (2)

2900HS PART NUMBERS & DIAGRAMS

GEAR PUMP PARTS

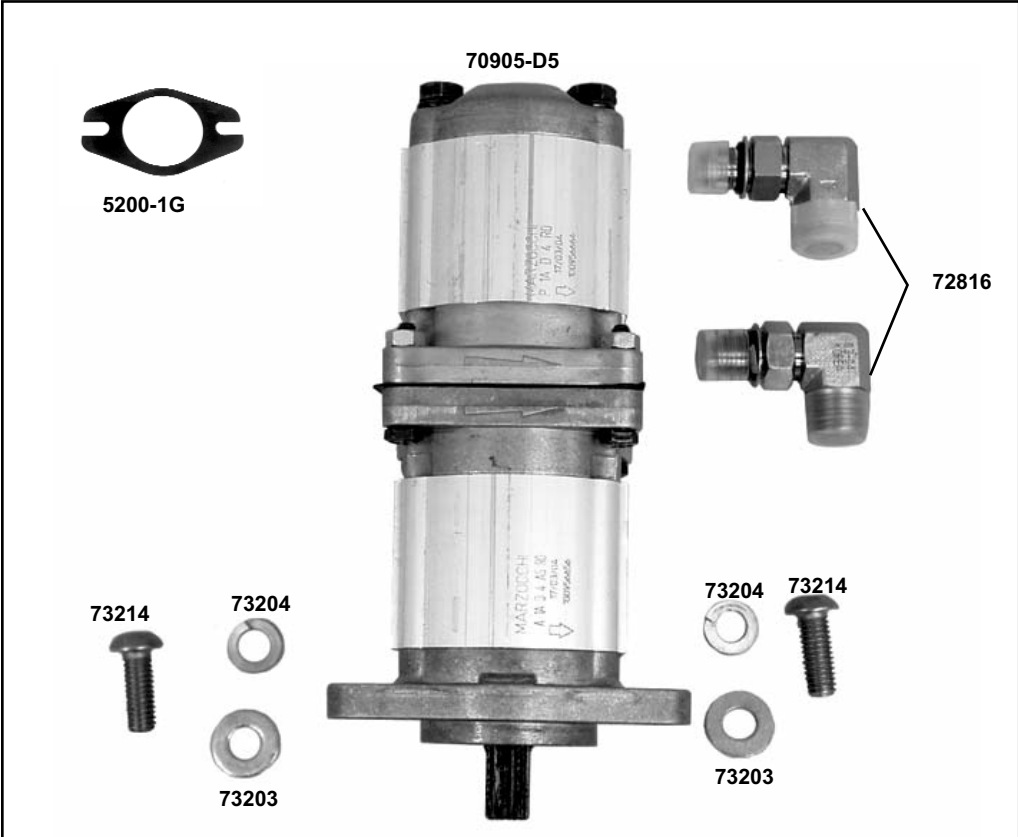

<u>PART #</u>	<u>DESCRIPTION</u>	<u>PART #</u>	<u>DESCRIPTION</u>
5200-1G	Double Pump Gasket	73204	3/8 Split Lock Washer (2)
70905-D5	Marzocchi Double Pump #5	73214	3/8-16 x 1 Button Head Socket Cap Screw (2)
72816	3/8 " 90° Pump Fitting (2)		
73203	3/8 SAE Flat Washer (2)		

2900HS PART NUMBERS & DIAGRAMS

WHEEL PARTS

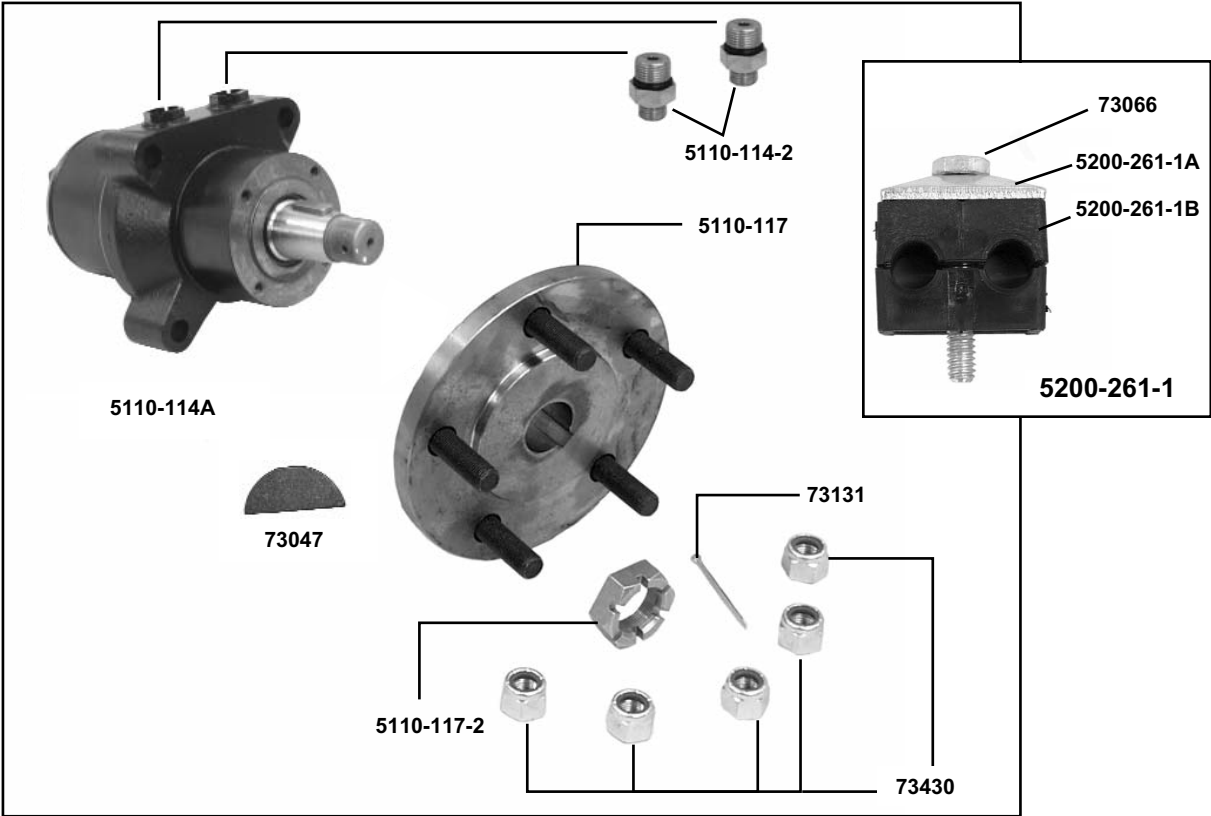

<u>PART #</u>	<u>DESCRIPTION</u>	<u>PART #</u>	<u>DESCRIPTION</u>
5110-114	Hydraulic Wheel Motor (Old Style) (2) (Not Shown)	5110-405	18" Wheel & Rim (Standard) (Not Shown)
5110-114A	High Speed Hyd. Wheel Motor (2)	5200-261-1	Wheel Motor Hose Clamp Assembly (2)
5110-114-2	Wheel Motor Fitting (4)	5200-261-1A	Clamp Cover (Only) (2)
5110-114-5	Wheel Motor Set of Seals (Old Style) (Not Shown)	5200-261-1B	Clamp Body (Only) (4)
5110-114-5A	Wheel Motor Set of Seals (New Style) (Not Shown)	73047	1/4 x 1 Woodruff Key (2)
5110-117	Wheel Hub (2)	73066	1/4-20 x 1 1/4 Clamp Bolt (2)
5110-117-2	Hub Nut (2)	73131	3/32 x 1 1/4 Cotter Pin (2)
		73430	1/2-20 Nylon Lock Nut (10)

2900HS PART NUMBERS & DIAGRAMS

SPOOL & HOSE PARTS

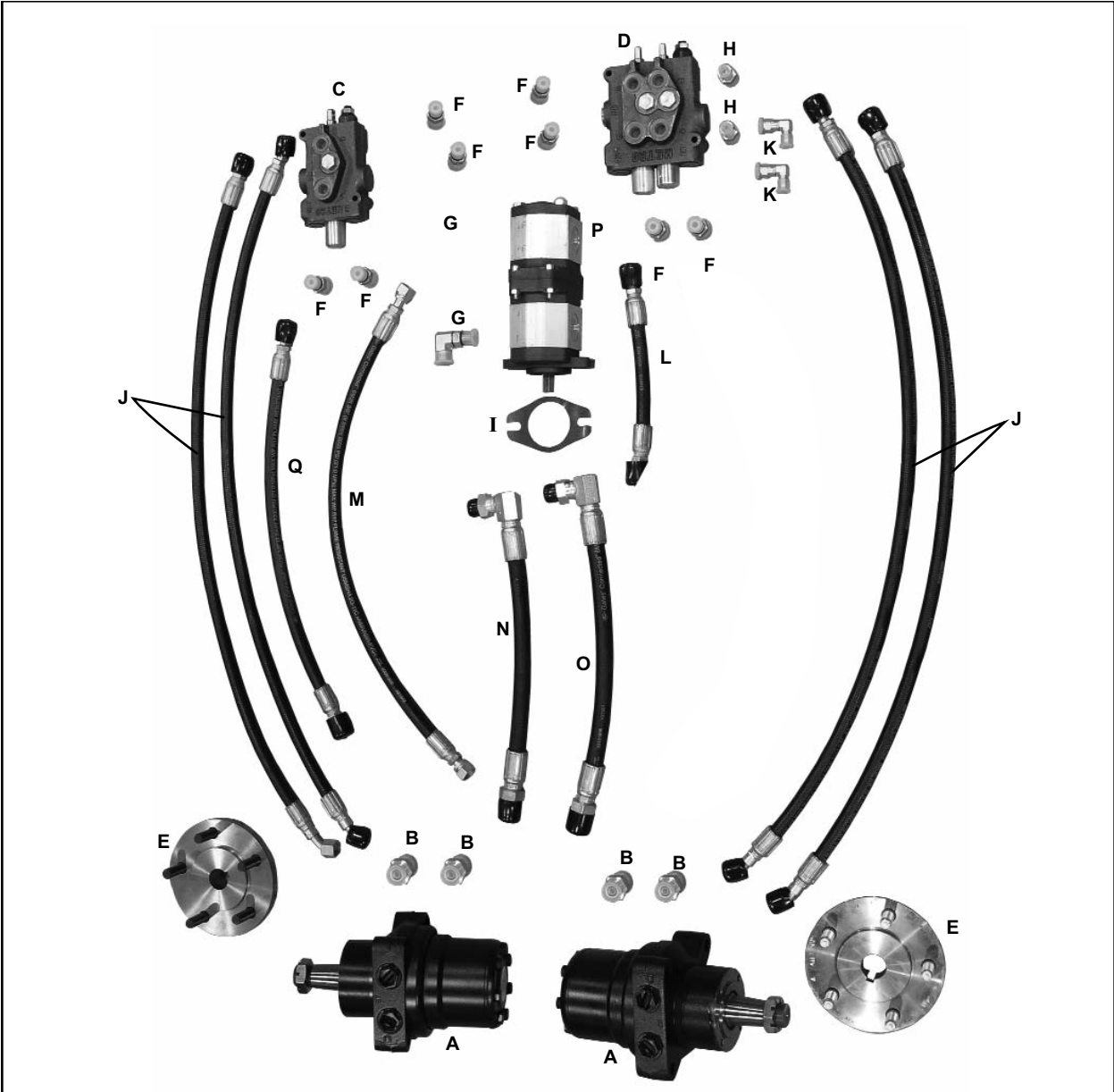

CODE	PART #	DESCRIPTION	CODE	PART #	DESCRIPTION
A	5110-114A	High Speed Hydraulic Wheel Motor (2)	J	5200-261	Wheel Motor Line (4)
B	5110-114-2	Wheel Motor Fitting (4)	K	5700-52	90° Valve Fitting (2)
C	5110-115	Single Spool Control	L	5700-71	Hose (Return, Right)
D	5110-116	Double Spool Control	M	5700-72	Hose (Return, Left) (1 or 2)
E	5110-117	Wheel Hub (2)	O	5200-263	Suction Hose Assembly (2)
F	5110-219	Straight Valve Body Plug (8)	P	5700-81	Suction Line
G	5200-111	(2)	Q	70905-D5	Hydraulic Double Pump #5
H	5110-268	Straight Valve Fitting (2)			
I	5200-1G	Double Pump Gasket			

2900HS PART NUMBERS & DIAGRAMS

FILTER & TANK PARTS

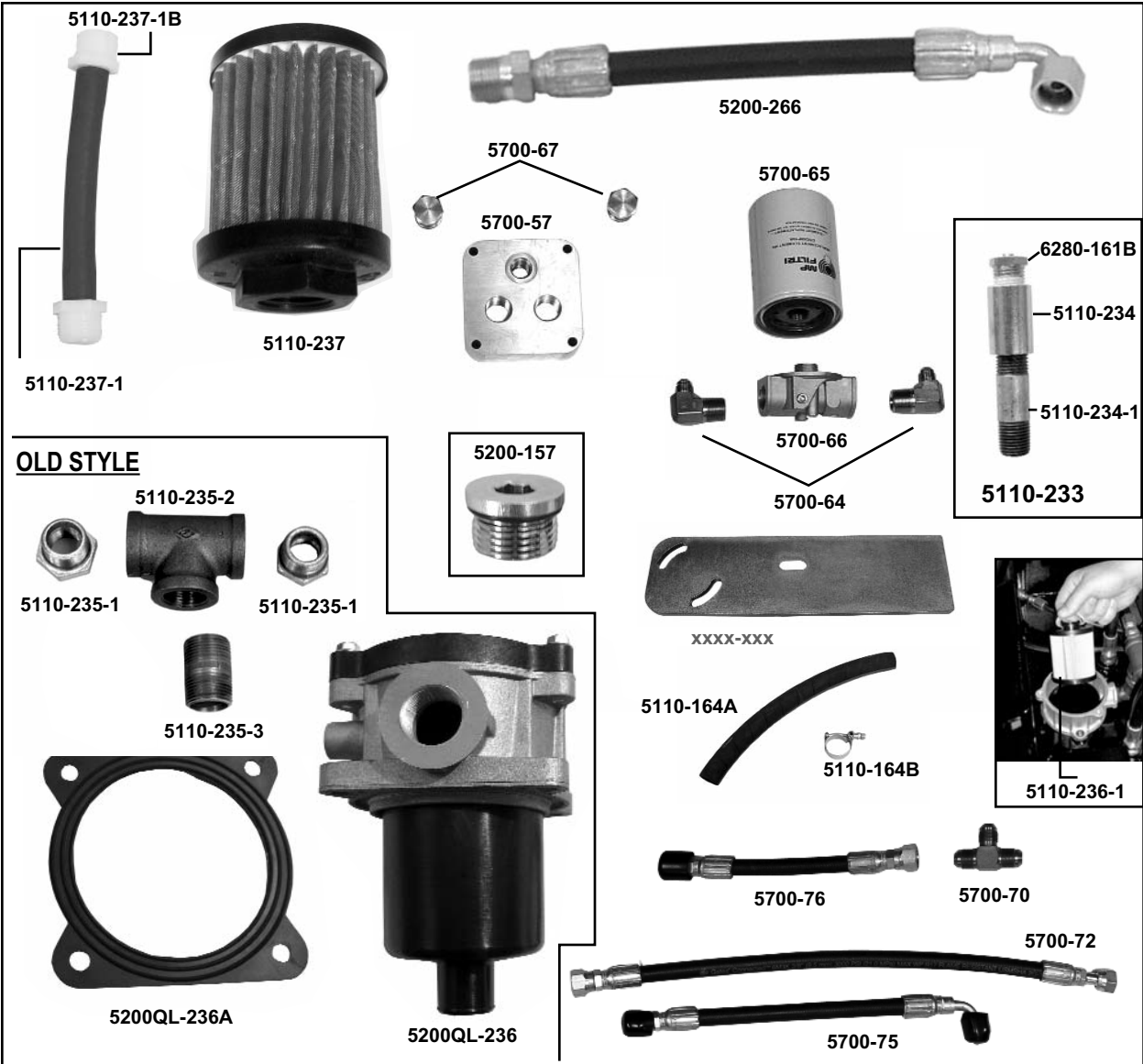

<u>PART #</u>	<u>DESCRIPTION</u>	<u>PART #</u>	<u>DESCRIPTION</u>	<u>PART #</u>	<u>DESCRIPTION</u>
5110-164A	Return Tank Hose	5110-237	Suction Filter Screen	5700-65	Filter
5110-164B	Return Tank Hose Clamp	5110-237-1	Filter Suction Line Assembly (2)	5700-66	Head
5110-233	Breather Assembly	5110-237-1B	Suction Hose Fitting(Only) (4)	5700-67	Tank Plug (2)
5110-234	Relief Valve Coupler (Only)	5200-157	Drain/Filler Plug (3)	5700-70	T-Fitting
5110-234-1	Relief Valve Nipple (Only)	5200-266	Return Line (2)	5700-72	Hose (Return, Left)
5110-235-1	Filter Hose Fitting Only (2) - OS	5200QL-236	Filter Housing Assmy - OS	5700-75	Hose (Pressure, Left-12.5)
5110-235-2	Filter "T" Only - OS	5200QL-236A	Filter Housing Gasket - OS	5700-76	Hose (Pressure, Right-25)
5110-235-3	Filter Coupler Only - OS	5700-57	Filter Block	6280-162G	Tank Magnet (Not Shown)
5110-236-1	Replacement Filter Return	5700-64	Filter Fitting (2)	XXXX-XXX	Bracket

Note: OS=Old Style

2900HS PART NUMBERS & DIAGRAMS

CONTROL LEVER PARTS (NEW STYLE)

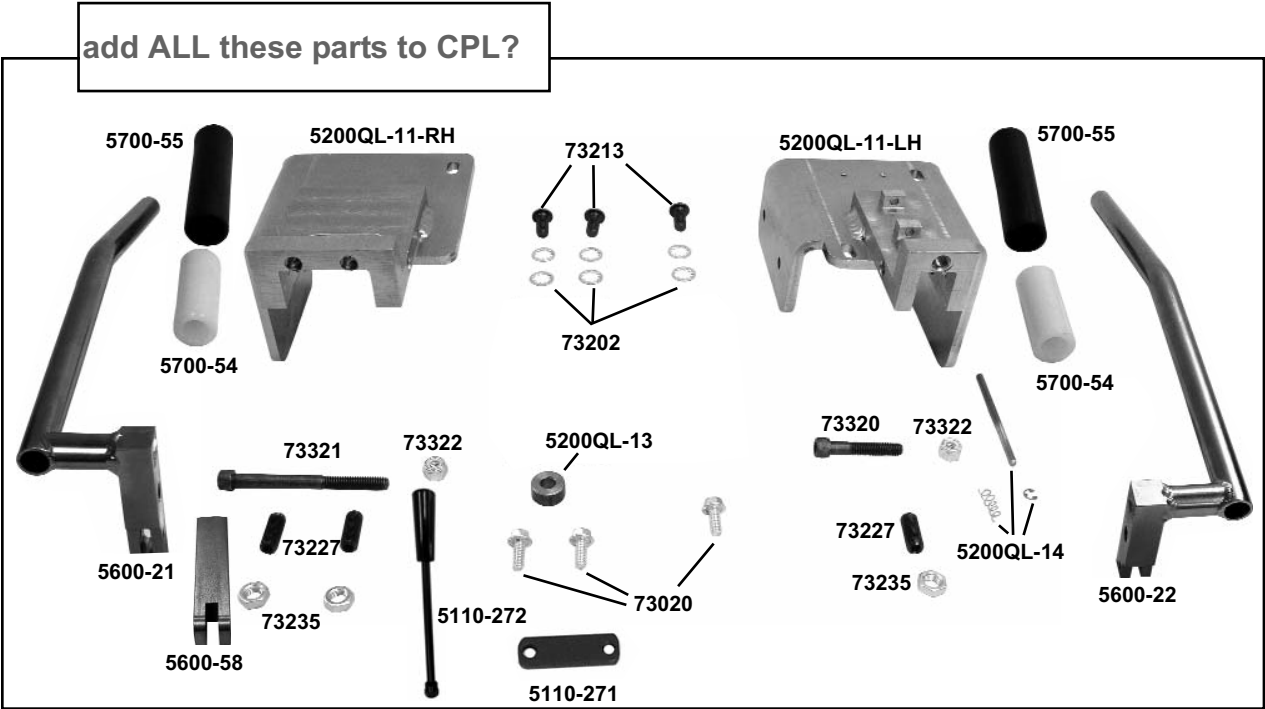

<u>PART #</u>	<u>DESCRIPTION</u>	6280-170A	Handle Rubber Cover (2)
5110-271	Lever Bracket	73020	1/4-20 x 5/8 Wizlock Bolt (3)
5110-272	Cylinder Lift Lever Only	73202	3/8 Internal Lock Washer (6)
5200QL-11-LH	Single Spool Valve	73213	3/8-16 x 3/4 Button Head Cap Screw (3)
5200QL-11-RH	Double Spool Valve	73227	3/8-24 x 1 Set Screw (3)
5200QL-13	Valve Lever Spacer	73235	3/8-24 Jamb Nut (3)
5200QL-14	Backup Beeper Pin Assembly	73320	5/16-18 x 2 Socket Head Cap Screw
5600-21	Handle Weldment, Left	73321	5/16-18 x 3 1/2 Socket Head Cap Screw
5600-22	Handle Weldment, Right	73322	5/16 Nylon Lock Nut (2)
5600-58	Valve Lever - Short		
5700-54	Handle Grip Sleeve (2)		
<u>PART #</u>	<u>DESCRIPTION</u>		

2900HS PART NUMBERS & DIAGRAMS

CYLINDER PARTS

CYLINDER

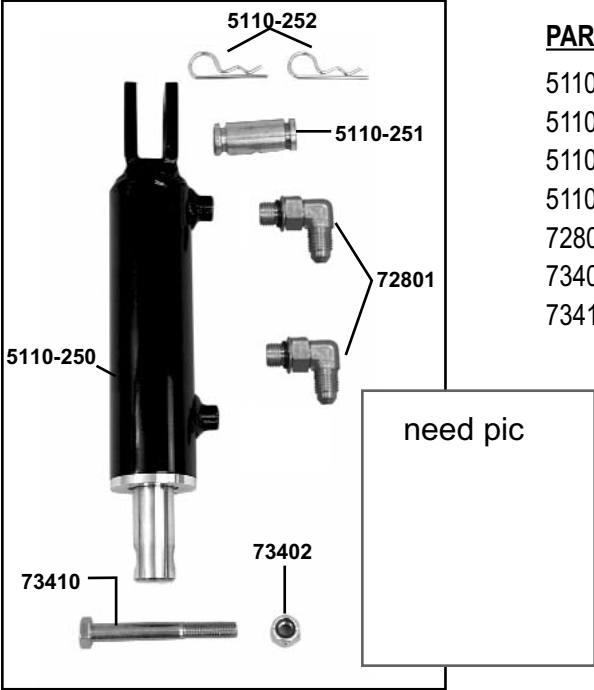

<u>PART #</u>	<u>DESCRIPTION</u>
5110-267	Cylinder Line Hoses
5110-250	Cylinder
5110-251	Cylinder Connecting Rod
5110-252	Cylinder Clip (2)
72801	1/4" 90° Fitting (2)
73402	1/2-13 Nylon Lock Nut
73410	1/2-13 x 3 1/2 Hexhead Cap Screw

CYLINDER HOSE GUARD

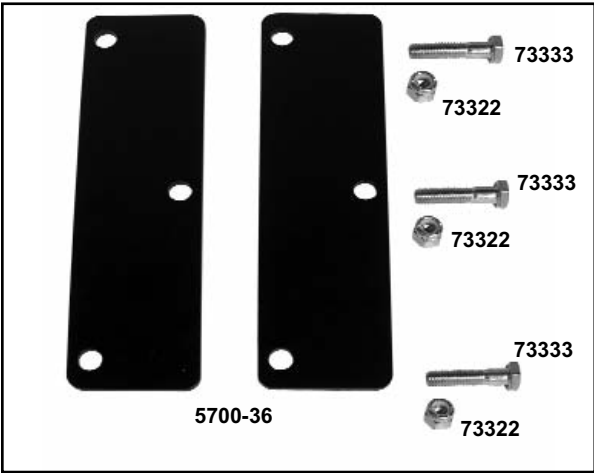

<u>PART #</u>	<u>DESCRIPTION</u>
5700-36	Hose Guard (2)
73322	5/16-18 Nylon Lock Nut (3)
73333	5/16-18 x 1 1/2 Socket Head Cap Screw (3)

CYLINDER REPL. SEAL KIT



<u>PART #</u>	<u>DESCRIPTION</u>
5110-250-3	Cylinder Seal Kit Replacement

2900HS PART NUMBERS & DIAGRAMS

SLIDE PLATE/DEFLECTOR, CASTER & FOOT PEG PARTS

SLIDE PLATE

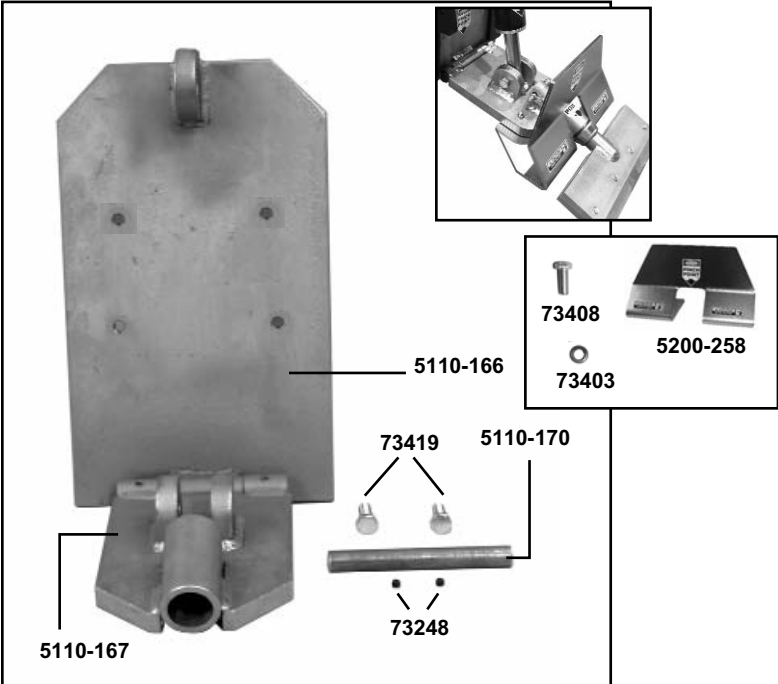

<u>PART #</u>	<u>DESCRIPTION</u>
5110-166	Slide Plate
5110-167	Lower Cutting Head Support
5110-170	Cutting Head Pin
5200-258	Debris Deflector
73248	5/16-18 x 1/4 Cup Point Socket Set Screw (2)
73403	1/2 Split Lock Washer (2)
73408	1/2-13 x 1 Hexhead Cap Screw (2)
73419	1/2-13 x 1-1/2 Hexhead Bolt -Grade 8 (6 or 2 ?)

CASTER

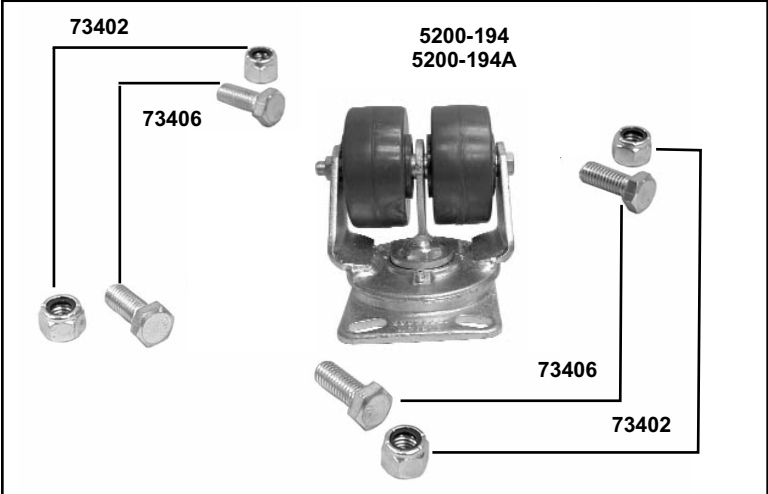

<u>PART #</u>	<u>DESCRIPTION</u>
5200-194	Double Wheel Caster Assembly (2 ?) (Grey)
5200-194A	Replacement Wheel Only (2) (Not Shown)
73402	1/2-13 Nylon Lock Nut (4)
73406	1/2-13 x 1-1/4 Bolt (5 or 4?)

FOOT PEG

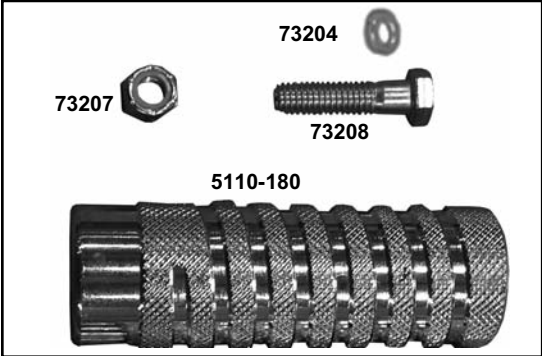

<u>PART #</u>	<u>DESCRIPTION</u>
5110-180	Foot Peg (2)
73204	3/8 Split Lock Washer (2)
73207	3/8-16 Nylon Lock Nut (2)
73208	3/8-16 x 1 1/2 Hexhead Cap Screw (2)

2900HS PART NUMBERS & DIAGRAMS

WEIGHTS, BATTERIES & CHARGER PARTS

WEIGHTS

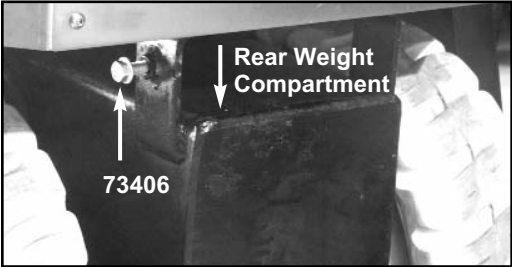

PART#

5110-404
73406

DESCRIPTION

Rear Weight
1/2-13 x 1-1/4 Hexhead Bolt (qty?)

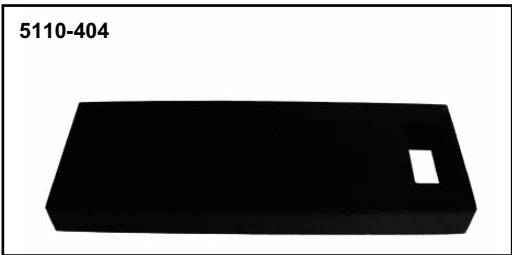

BATTERIES

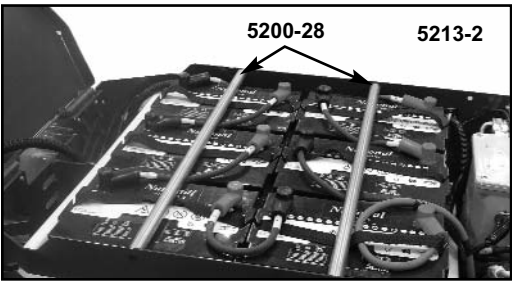

PART #

5200-28
5213-2

DESCRIPTION

Side Support Rod (2)
8 Volt Battery, 180 AH (6)

CHARGER

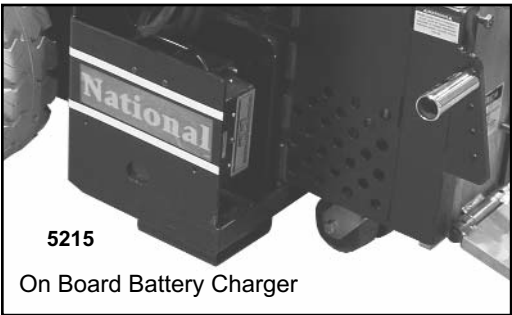

PART #

5215
72705

DESCRIPTION

On Board Charger, 48V 115 V
50 Amp 48 Volt Charger Connector Only



2900HS LABELS

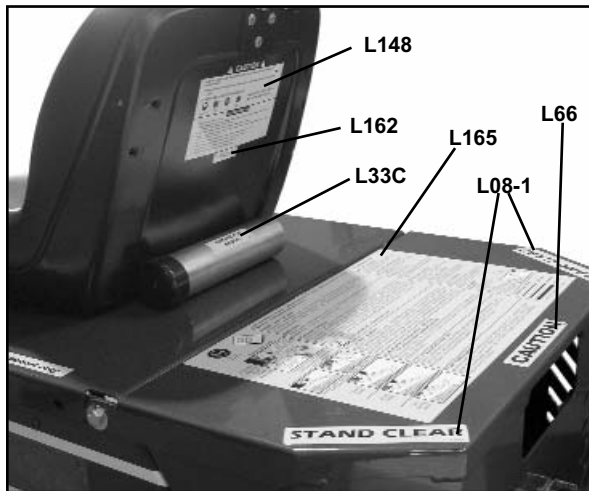
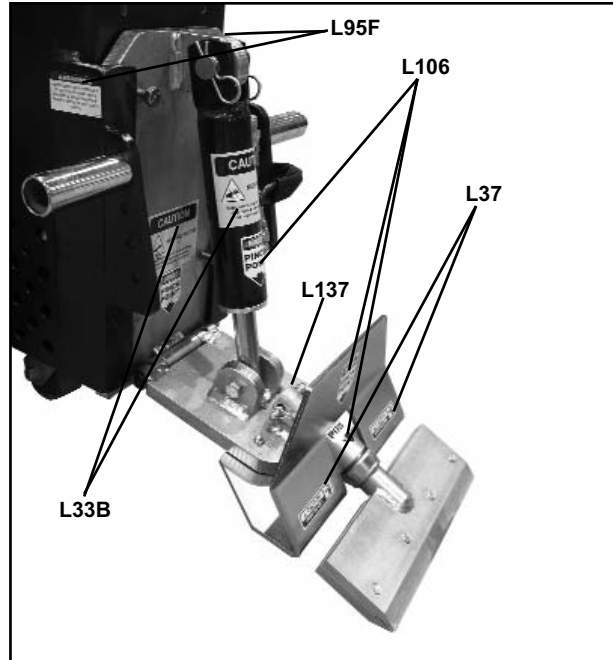
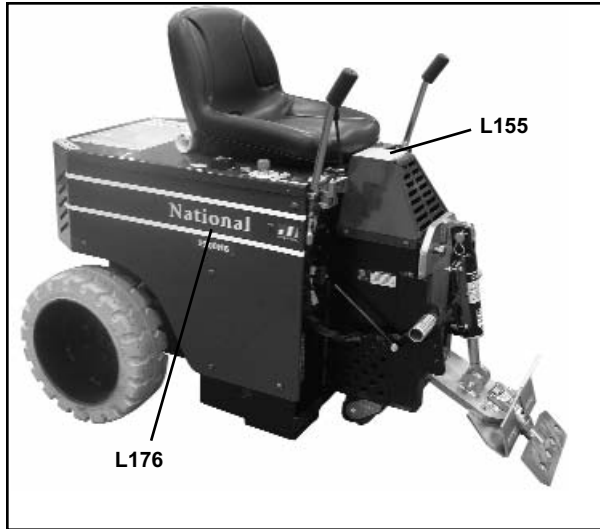

<u>PART #</u>	<u>DESCRIPTION</u>	<u>PART #</u>	<u>DESCRIPTION</u>
L08-1	Stand Clear Label (2)	L137	Disarm Machine Label
L33B	Caution Moving Parts Label (2)	L142	Trailer Hitch Label
L33C	Instruction Manual Label	L148	General Info Label
L37	Caution Sharp Blades Label (2)	L155	General Warning Label
L38	Disconnect Before Servicing Label (Not Shown)	L162	48 Volt VDC Label
L66	Large Caution Label	L165	Large Ride-On Label w/ Blade Info
L95F	Fluid Leak Label (2 - One on each side)	L176	National Label, Large (2-One on each side)
L106	Pinch Point Label (3)		

2900HS LABELS

RIGHT VIEW

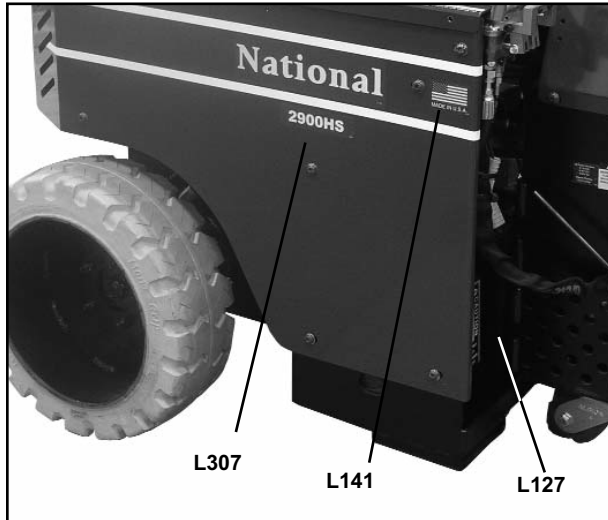

PART

L127
L141
L307

DESCRIPTION

Caution Operating Temp Label
Flag/Made in USA Label
2900HS Stock Number Label

LEFT VIEW

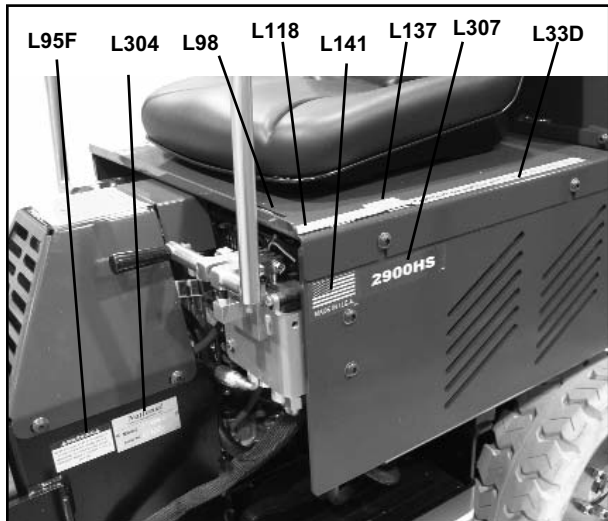

PART

L33D
L95F
L98
L118
L137
L141
L304

L307

DESCRIPTION

Authorized Personnel Only Label
Fluid Leak Label (2)
Blade Lift Label
Operator Must Be Seated Label
Warning Disarm Machine Label (2)
Flag/Made in USA Label
Metal Serial Number Plate (Not Shown?)
2900HS Stock Number Label

2900HS ACCESSORIES

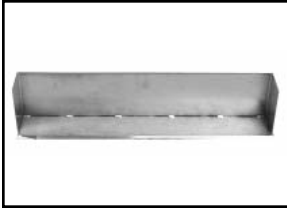

7074 TILE BOX

The Tile Box works for wind rowing and assists for a fast clean-up and collection of tile debris for quick removal. High abrasion alloy for a long lasting edge. Resharpens just like a blade. 5" x 27" x 6" box. Attaches to the #7050-27 Cutting Head (required).

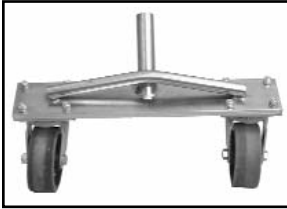

5110-100 FRONT WHEEL ASSEMBLY

Allows stability and safe transportation over any surface. Easy and quick to attach.

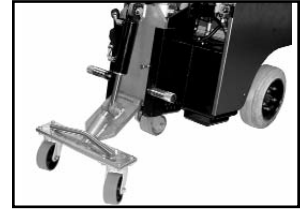

5110-100W Replacement Wheel Only

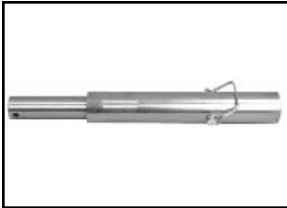

7050-15 CUTTING HEAD EXTENSION

Extension for cutting heads to reach under tight areas.



5110-111-3 OPTIONAL ARM RESTS/ SET

Optional Arm Rests for added comfort. Set includes left and right arm rest and mounting hardware.



1009 SAFETY GLASSES

Large frame • Flat fold side shields • Clear lens • ANSI certified

2900HS BLADES & CUTTING HEADS

CUTTING HEADS

Swivel heads rotate to use the second sharp edge of the blade without having to remove the blade. Swivel head allows blade to stay in contact with the floor.

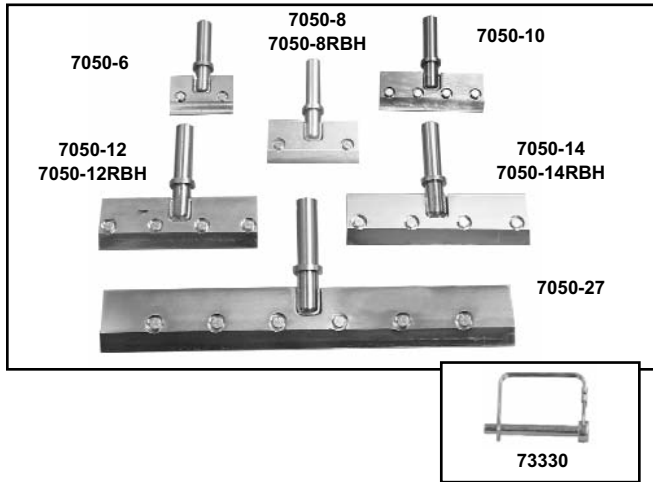

7050-6	6" CUTTING HEAD
7050-8	8" CUTTING HEAD
7050-10	10" CUTTING HEAD
7050-12	12" CUTTING HEAD
7050-14	14" CUTTING HEAD
7050-27	27" CUTTING HEAD
7050-8RBH	8" RAZOR BLADE HEAD
7050-12RBH	12" RAZOR BLADE HEAD
7050-14RBH	14" RAZOR BLADE HEAD
73330	5/16 X 2 LOCK PIN Secures cutting head assemblies

TAPERED CUTTING HEAD SHANK BLADES

Designed for removing wood and the toughest removals. Blades are mounted at an angle to achieve the optimum shear point for the best performance.

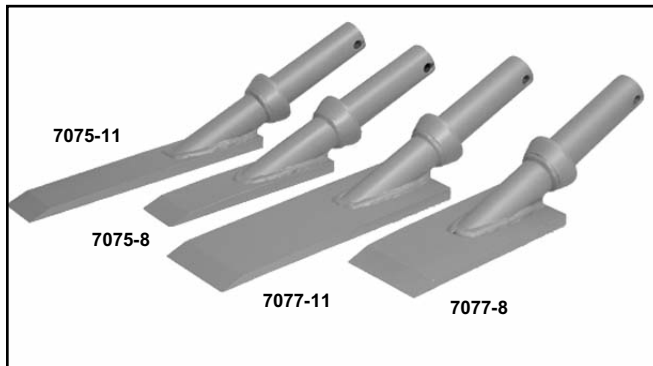

7075-8	2" X 8" TAPERED CUTTING HEAD SHANK
7075-11	2" X 11" TAPERED CUTTING HEAD SHANK
7077-8	3.5" X 8" TAPERED CUTTING HEAD SHANK
7077-11	3.5" X 11" TAPERED CUTTING HEAD SHANK

TAPERED CUTTING HEAD SHANKS WITH CARBIDE TIPS

Works on wood and ceramic. Blades are mounted at an angle to achieve the optimum shear point for the best performance. Nothing else performs like carbide when no other blade will work.

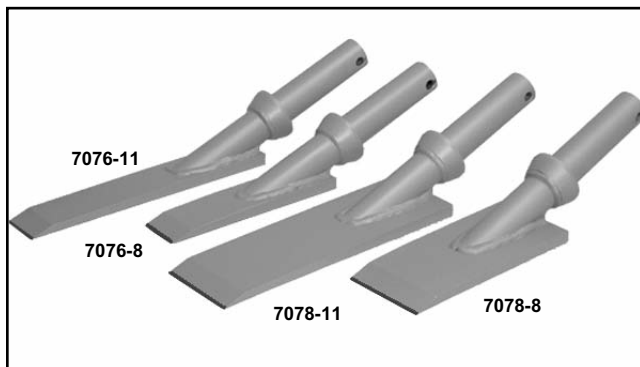

7076-8	2" X 8" TAPERED CUTTING HEAD SHANK W/ CARBIDE TIP
7076-11	2" X 11" TAPERED CUTTING HEAD SHANK W/ CARBIDE TIP
7078-8	3.5" X 8" TAPERED CUTTING HEAD W/ CARBIDE TIP
7078-11	3.5" X 11" TAPERED CUTTING HEAD SHANK W/ CARBIDE TIP

2900HS BLADES & CUTTING HEADS

STRAIGHT SHANK BLADES

The ultimate for tough removals. Works well for ceramic, wood and thick epoxy.



7070-2	2" STRAIGHT SHANK BLADE
7070-3	3" STRAIGHT SHANK BLADE
7070-4	4" STRAIGHT SHANK BLADE
7070-6	6" STRAIGHT SHANK BLADE

ANGLE SHANK/SHOE BLADES

The same application as the #7070 blades, but is mounted at an angle to achieve the optimum shear point for optimum performance. Works well for ceramic and thick epoxy.



7071-2	2" ANGLE SHANK/SHOE BLADE
7071-3	3" ANGLE SHANK/SHOE BLADE
7071-4	4" ANGLE SHANK/SHOE BLADE
7071-6	6" ANGLE SHANK/SHOE BLADE

STRAIGHT SHANKS WITH CARBIDE TIP

The same application as the #7070 blades, but are carbide tipped for holding a sharp edge for long periods. Works well for ceramic and thick epoxy.



7072-2	2" STRAIGHT SHANK W/ CARBIDE TIP
7072-3	3" STRAIGHT SHANK W/ CARBIDE TIP
7072-4	4" STRAIGHT SHANK W/ CARBIDE TIP
7072-6	6" STRAIGHT SHANK W/ CARBIDE TIP

EXTRA HEAVY DUTY CERAMIC EPOXY SHANKS WITH CARBIDE TIP

Designed for ceramic removal and thin-set rescraping. 1/2" of carbide which is twice the carbide of the #7072 & #7073 series blades. The extra carbide allows for maximum resharping. Strong enough to work on machines up to 3500 lbs.



7079-2	2" EXTRA HD CERAMIC EPOXY SHANK W/ CARBIDE TIP
7079-4	4" EXTRA HD CERAMIC EPOXY SHANK W/ CARBIDE TIP
7079-6	6" EXTRA HD CERAMIC EPOXY SHANK W/ CARBIDE TIP

Note: Run time will be depleted if machine is used on difficult removals such as ceramic & wood

2900HS MACHINE WIRING

2900 Control Box Wiring

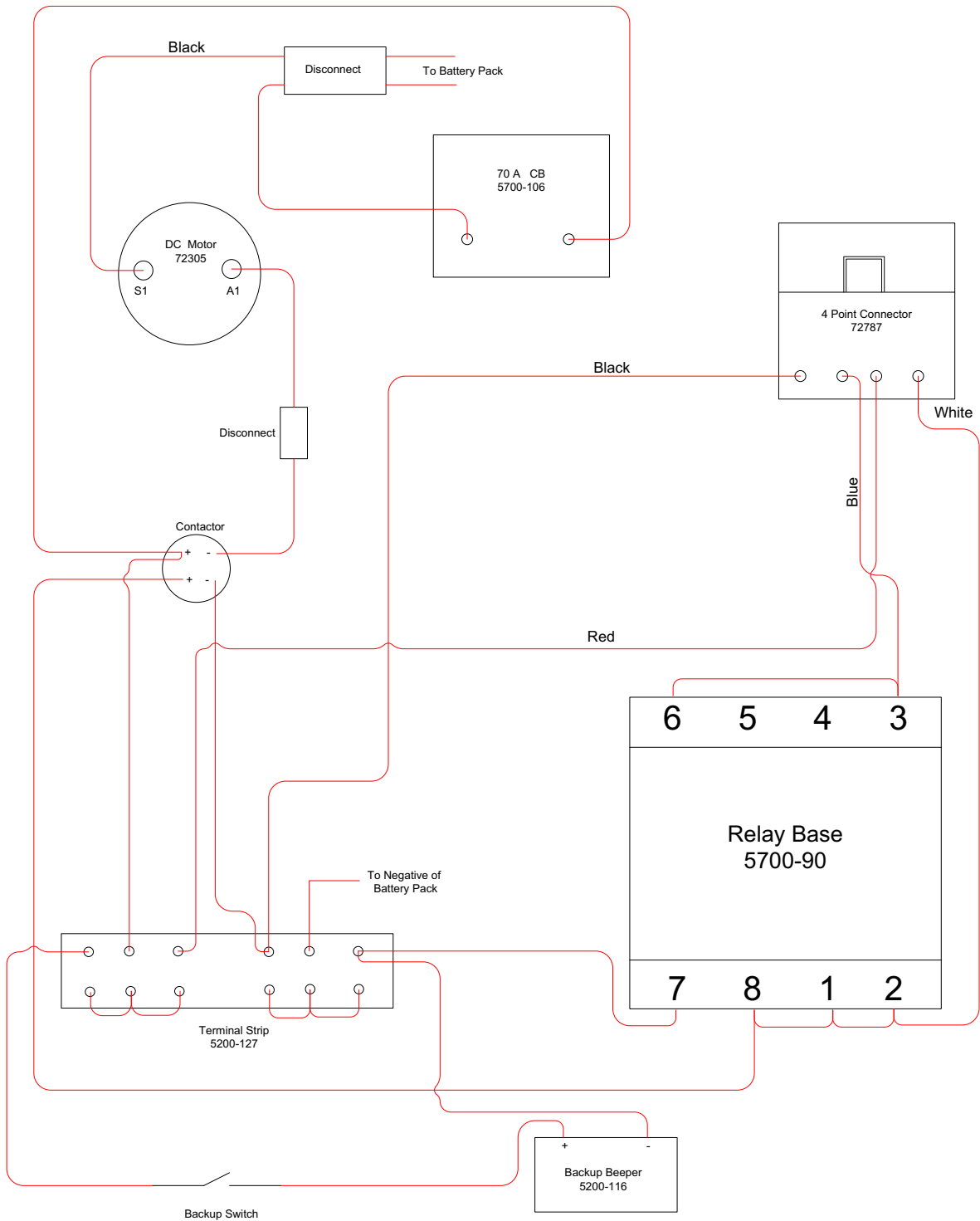

2900HS BATTERY WIRING

2900 BATTERY WIRING

Rear of Machine

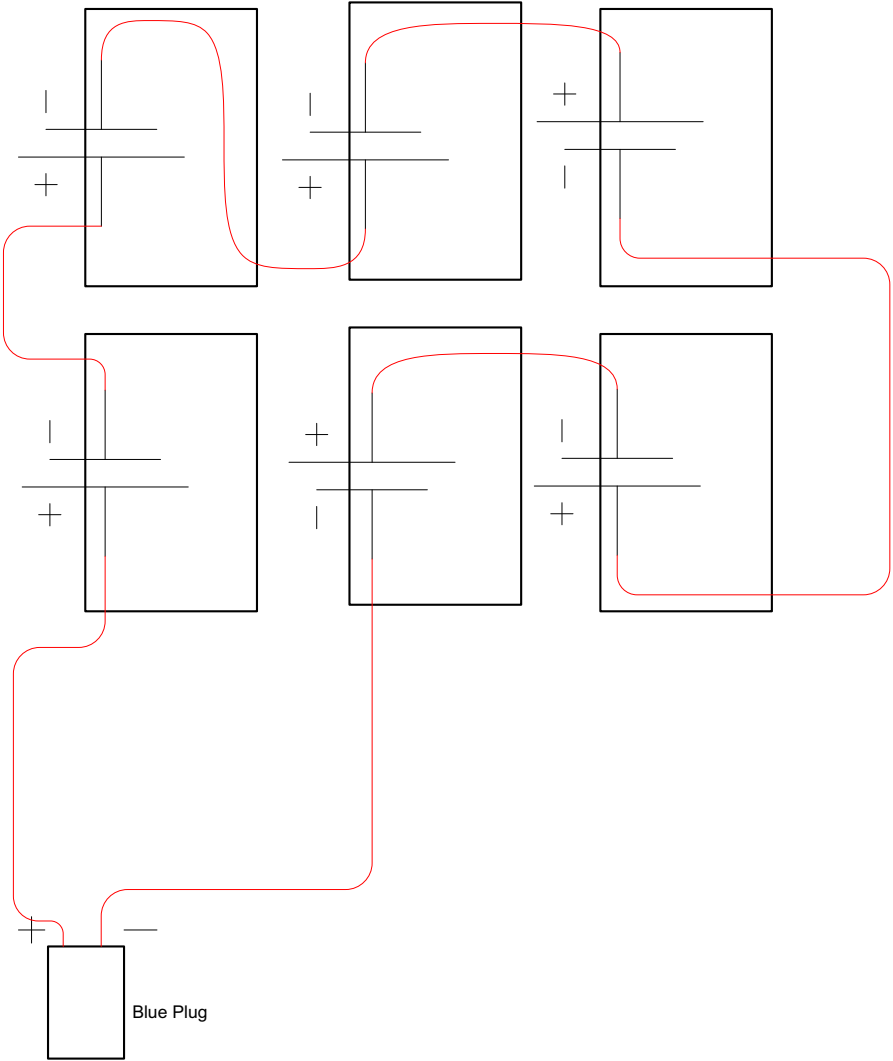

2900HS SEAT WIRING

2900 Seat Wiring

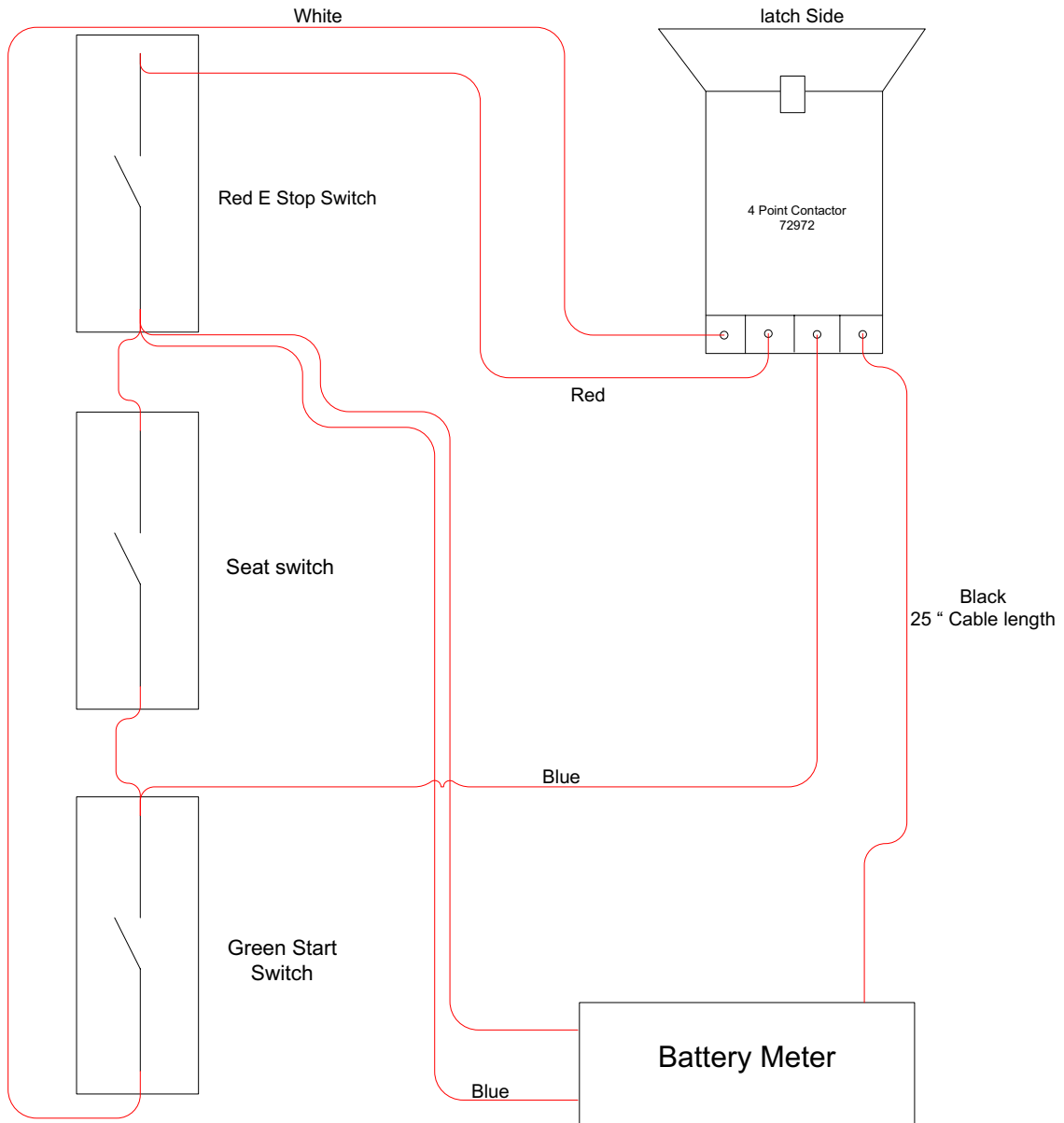

2900HS MATERIAL SAFETY DATA

Material Safety Data Sheet

SECTION 1 PRODUCT AND COMPANY IDENTIFICATION

Texaco Rando® HD 22 - 68

Product Number(s): CPS221655, CPS221657, CPS221658, CPS221659

Synonyms: Texaco Rando® HD 22, Texaco Rando® HD 32, Texaco Rando® HD 46, Texaco Rando® HD 68

Company Identification

Chevron Products Company
a division of Chevron U.S.A. Inc.
6001 Bollinger Canyon Road
San Ramon, CA 94583
United States of America
www.chevronlubricants.com

Transportation Emergency Response

CHEMTREC: (800) 424-9300 or (703) 527-3887

Health Emergency

Chevron Emergency Information Center: Located in the USA. International collect calls accepted. (800) 231-0623 or (510) 231-0623

Product Information

email : lubemsds@chevron.com
Product Information: 800-LUBE-TEK
MSDS Requests: 800-414-6737

SECTION 2 COMPOSITION/ INFORMATION ON INGREDIENTS

COMPONENTS	CAS NUMBER	AMOUNT
Highly refined mineral oil (C15 - C50)	Mixture	90 - 100 %weight

SECTION 3 HAZARDS IDENTIFICATION

IMMEDIATE HEALTH EFFECTS

Eye: Not expected to cause prolonged or significant eye irritation.

Skin: Contact with the skin is not expected to cause prolonged or significant irritation. Not expected to be harmful to internal organs if absorbed through the skin. High-Pressure Equipment Information: Accidental high-velocity injection under the skin of materials of this type may result in serious injury. Seek medical attention at once should an accident like this occur. The initial wound at the injection site may not appear to be serious at first; but, if left untreated, could result in disfigurement or amputation of the affected part.

Ingestion: Not expected to be harmful if swallowed.

Inhalation: Not expected to be harmful if inhaled. Contains a petroleum-based mineral oil. May cause respiratory irritation or other pulmonary effects following prolonged or repeated inhalation of oil mist at airborne levels above the recommended mineral oil mist exposure limit. Symptoms of respiratory irritation may include coughing and difficulty breathing.

SECTION 4 FIRST AID MEASURES

Eye: No specific first aid measures are required. As a precaution, remove contact lenses, if worn, and flush eyes with water.

2900HS MATERIAL SAFETY DATA

Skin: No specific first aid measures are required. As a precaution, remove clothing and shoes if contaminated. To remove the material from skin, use soap and water. Discard contaminated clothing and shoes or thoroughly clean before reuse.

Ingestion: No specific first aid measures are required. Do not induce vomiting. As a precaution, get medical advice.

Inhalation: No specific first aid measures are required. If exposed to excessive levels of material in the air, move the exposed person to fresh air. Get medical attention if coughing or respiratory discomfort occurs.

Note to Physicians: In an accident involving high-pressure equipment, this product may be injected under the skin. Such an accident may result in a small, sometimes bloodless, puncture wound. However, because of its driving force, material injected into a fingertip can be deposited into the palm of the hand. Within 24 hours, there is usually a great deal of swelling, discoloration, and intense throbbing pain. Immediate treatment at a surgical emergency center is recommended.

SECTION 5 FIRE FIGHTING MEASURES

Leaks/ruptures in high pressure system using materials of this type can create a fire hazard when in the vicinity of ignition sources (eg. open flame, pilot lights, sparks, or electric arcs).

FIRE CLASSIFICATION:

OSHA Classification (29 CFR 1910.1200): Not classified by OSHA as flammable or combustible.

NFPA RATINGS: Health: 0 Flammability: 1 Reactivity: 0

FLAMMABLE PROPERTIES:

Flashpoint: (Cleveland Open Cup) 150 °C (302 °F) (Min)

Autoignition: No Data Available

Flammability (Explosive) Limits (% by volume in air): Lower: Not Applicable Upper: Not Applicable

EXTINGUISHING MEDIA: Use water fog, foam, dry chemical or carbon dioxide (CO₂) to extinguish flames.

PROTECTION OF FIRE FIGHTERS:

Fire Fighting Instructions: This material will burn although it is not easily ignited. For fires involving this material, do not enter any enclosed or confined fire space without proper protective equipment, including self-contained breathing apparatus.

Combustion Products: Highly dependent on combustion conditions. A complex mixture of airborne solids, liquids, and gases including carbon monoxide, carbon dioxide, and unidentified organic compounds will be evolved when this material undergoes combustion.

SECTION 6 ACCIDENTAL RELEASE MEASURES

Protective Measures: Eliminate all sources of ignition in vicinity of spilled material.

Spill Management: Stop the source of the release if you can do it without risk. Contain release to prevent further contamination of soil, surface water or groundwater. Clean up spill as soon as possible, observing precautions in Exposure Controls/Personal Protection. Use appropriate techniques such as applying non-combustible absorbent materials or pumping. Where feasible and appropriate, remove contaminated soil. Place contaminated materials in disposable containers and dispose of in a manner consistent with applicable regulations.

Reporting: Report spills to local authorities and/or the U.S. Coast Guard's National Response Center at (800) 424-8802 as appropriate or required.

SECTION 7 HANDLING AND STORAGE

Precautionary Measures: DO NOT USE IN HIGH PRESSURE SYSTEMS in the vicinity of flames, sparks and hot surfaces. Use only in well ventilated areas. Keep container closed.

General Handling Information: Avoid contaminating soil or releasing this material into sewage and drainage systems and bodies of water.

Static Hazard: Electrostatic charge may accumulate and create a hazardous condition when handling this material. To minimize this hazard, bonding and grounding may be necessary but may not, by themselves, be sufficient. Review all operations which have the potential of generating and accumulating an electrostatic charge and/or a flammable atmosphere (including tank and container filling, splash filling, tank cleaning, sampling, gauging, switch loading, filtering, mixing, agitation, and vacuum truck operations) and use appropriate mitigating procedures. For more information, refer to OSHA Standard 29 CFR 1910.106, 'Flammable and Combustible

2900HS MATERIAL SAFETY DATA

Liquids', National Fire Protection Association (NFPA 77, 'Recommended Practice on Static Electricity', and/or the American Petroleum Institute (API) Recommended Practice 2003, 'Protection Against Ignitions Arising Out of Static, Lightning, and Stray Currents'.

Container Warnings: Container is not designed to contain pressure. Do not use pressure to empty container or it may rupture with explosive force. Empty containers retain product residue (solid, liquid, and/or vapor) and can be dangerous. Do not pressurize, cut, weld, braze, solder, drill, grind, or expose such containers to heat, flame, sparks, static electricity, or other sources of ignition. They may explode and cause injury or death. Empty containers should be completely drained, properly closed, and promptly returned to a drum reconditioner or disposed of properly.

SECTION 8 EXPOSURE CONTROLS/PERSONAL PROTECTION

GENERAL CONSIDERATIONS:

Consider the potential hazards of this material (see Section 3), applicable exposure limits, job activities, and other substances in the work place when designing engineering controls and selecting personal protective equipment. If engineering controls or work practices are not adequate to prevent exposure to harmful levels of this material, the personal protective equipment listed below is recommended. The user should read and understand all instructions and limitations supplied with the equipment since protection is usually provided for a limited time or under certain circumstances.

ENGINEERING CONTROLS:

Use in a well-ventilated area.

PERSONAL PROTECTIVE EQUIPMENT

Eye/Face Protection: No special eye protection is normally required. Where splashing is possible, wear safety glasses with side shields as a good safety practice.

Skin Protection: No special protective clothing is normally required. Where splashing is possible, select protective clothing depending on operations conducted, physical requirements and other substances in the workplace. Suggested materials for protective gloves include: 4H (PE/EVAL), Nitrile Rubber, Silver Shield, Viton.

Respiratory Protection: No respiratory protection is normally required.

If user operations generate an oil mist, determine if airborne concentrations are below the occupational exposure limit for mineral oil mist. If not, wear an approved respirator that provides adequate protection from the measured concentrations of this material. For air-purifying respirators use a particulate cartridge.

Use a positive pressure air-supplying respirator in circumstances where air-purifying respirators may not provide adequate protection.

SECTION 9 PHYSICAL AND CHEMICAL PROPERTIES

Attention: the data below are typical values and do not constitute a specification.

Color: Yellow

Physical State: Liquid

Odor: Petroleum odor

pH: Not Applicable

Vapor Pressure: <0.01 mmHg @ 37.8 °C (100 °F)

Vapor Density (Air = 1): >1

Boiling Point: >315.6°C (600°F)

Solubility: Soluble in hydrocarbons; insoluble in water

Freezing Point: Not Applicable

Melting Point: Not Applicable

Specific Gravity: 0.86 - 0.87 @ 15.6°C (60.1°F) / 15.6°C (60.1°F)

Density: 0.86 kg/l - 0.9 kg/l @ 15°C (59°F)

Viscosity: 22 cSt - 61.2 cSt @ 40°C (104°F) (Min)

SECTION 10 STABILITY AND REACTIVITY

Chemical Stability: This material is considered stable under normal ambient and anticipated storage and handling conditions of temperature and pressure.

Incompatibility With Other Materials: May react with strong acids or strong oxidizing agents, such as chlorates, nitrates, peroxides, etc.

Hazardous Decomposition Products: None known (None expected)

2900HS MATERIAL SAFETY DATA

Hazardous Polymerization: Hazardous polymerization will not occur.

SECTION 11 TOXICOLOGICAL INFORMATION

IMMEDIATE HEALTH EFFECTS

Eye Irritation: The eye irritation hazard is based on evaluation of data for similar materials or product components.

Skin Irritation: The skin irritation hazard is based on evaluation of data for similar materials or product components.

Skin Sensitization: No product toxicology data available.

Acute Dermal Toxicity: The acute dermal toxicity hazard is based on evaluation of data for similar materials or product components.

Acute Oral Toxicity: The acute oral toxicity hazard is based on evaluation of data for similar materials or product components.

Acute Inhalation Toxicity: The acute inhalation toxicity hazard is based on evaluation of data for similar materials or product components.

ADDITIONAL TOXICOLOGY INFORMATION:

This product contains petroleum base oils which may be refined by various processes including severe solvent extraction, severe hydrocracking, or severe hydrotreating. None of the oils requires a cancer warning under the OSHA Hazard Communication Standard (29 CFR 1910.1200). These oils have not been listed in the National Toxicology Program (NTP) Annual Report nor have they been classified by the International Agency for Research on Cancer (IARC) as; carcinogenic to humans (Group 1), probably carcinogenic to humans (Group 2A), or possibly carcinogenic to humans (Group 2B). These oils have not been classified by the American Conference of Governmental Industrial Hygienists (ACGIH) as: confirmed human carcinogen (A1), suspected human carcinogen (A2), or confirmed animal carcinogen with unknown relevance to humans (A3).

SECTION 12 ECOLOGICAL INFORMATION

ECOTOXICITY

This material is not expected to be harmful to aquatic organisms. The ecotoxicity hazard is based on an evaluation of data for the components or a similar material.

ENVIRONMENTAL FATE

This material is not expected to be readily biodegradable.

SECTION 13 DISPOSAL CONSIDERATIONS

Use material for its intended purpose or recycle if possible. Oil collection services are available for used oil recycling or disposal. Place contaminated materials in containers and dispose of in a manner consistent with applicable regulations. Contact your sales representative or local environmental or health authorities for approved disposal or recycling methods.

SECTION 14 TRANSPORT INFORMATION

The description shown may not apply to all shipping situations. Consult 49CFR, or appropriate Dangerous Goods Regulations, for additional description requirements (e.g., technical name) and mode-specific or quantity-specific shipping requirements.

DOT Shipping Description: PETROLEUM LUBRICATING OIL, NOT REGULATED AS A HAZARDOUS MATERIAL FOR TRANSPORTATION UNDER 49 CFR

Additional Information: NOT HAZARDOUS BY U.S. DOT. ADR/RID HAZARD CLASS NOT APPLICABLE.

IMO/IMDG Shipping Description: PETROLEUM LUBRICATING OIL; NOT REGULATED AS DANGEROUS GOODS FOR TRANSPORT UNDER THE IMDG CODE

ICAO/IATA Shipping Description: PETROLEUM LUBRICATING OIL; NOT REGULATED AS DANGEROUS GOODS FOR TRANSPORT UNDER ICAO

2900HS MATERIAL SAFETY DATA

SECTION 15 REGULATORY INFORMATION

- EPCRA 311/312 CATEGORIES:** 1. Immediate (Acute) Health Effects: NO
2. Delayed (Chronic) Health Effects: NO
3. Fire Hazard: NO
4. Sudden Release of Pressure Hazard: NO
5. Reactivity Hazard: NO

REGULATORY LISTS SEARCHED:

01-1=IARC Group 1	03=EPCRA 313
01-2A=IARC Group 2A	04=CA Proposition 65
01-2B=IARC Group 2B	05=MA RTK
02=NTP Carcinogen0	6=NJ RTK
	07=PA RTK

No components of this material were found on the regulatory lists above.

CHEMICAL INVENTORIES:

All components comply with the following chemical inventory requirements: AICS (Australia), DSL (Canada), ENCS (Japan), IECSC (China), KECI (Korea), PICCS (Philippines), TSCA (United States).

One or more components is listed on ELINCS (European Union). Secondary notification by the importer may be required.

NEW JERSEY RTK CLASSIFICATION:

Under the New Jersey Right-to-Know Act L. 1983 Chapter 315 N.J.S.A. 34:5A-1 et. seq., the product is to be identified as follows: PETROLEUM OIL (Hydraulic oil)

WHMIS CLASSIFICATION:

This product is not considered a controlled product according to the criteria of the Canadian Controlled Products Regulations.

SECTION 16 OTHER INFORMATION

NFPA RATINGS: Health: 0 Flammability: 1 Reactivity: 0

HMIS RATINGS: Health: 1 Flammability: 1 Reactivity: 0
(0-Least, 1-Slight, 2-Moderate, 3-High, 4-Extreme, PPE:- Personal Protection Equipment Index recommendation, *- Chronic Effect Indicator). These values are obtained using the guidelines or published evaluations prepared by the National Fire Protection Association (NFPA) or the National Paint and Coating Association (for HMIS ratings).

LABEL RECOMMENDATION:

Label Category : INDUSTRIAL OIL 1 - IND1

REVISION STATEMENT: This revision updates the following sections of this Material Safety Data Sheet: 2.
Revision Date: January 15, 2007

ABBREVIATIONS THAT MAY HAVE BEEN USED IN THIS DOCUMENT:

TLV - Threshold Limit Value	TWA - Time Weighted Average
STEL - Short-term Exposure Limit	PEL - Permissible Exposure Limit
	CAS - Chemical Abstract Service Number
ACGIH - American Conference of Government Industrial Hygienists	IMO/IMDG - International Maritime Dangerous Goods Code
API - American Petroleum Institute	MSDS - Material Safety Data Sheet

2900HS MATERIAL SAFETY DATA

CVX - Chevron	NFPA - National Fire Protection Association (USA)
DOT - Department of Transportation (USA)	NTP - National Toxicology Program (USA)
IARC - International Agency for Research on Cancer	OSHA - Occupational Safety and Health Administration

Prepared according to the OSHA Hazard Communication Standard (29 CFR 1910.1200) and the ANSI MSDS Standard (Z400.1) by the Chevron Energy Technology Company, 100 Chevron Way, Richmond, California 94802.

The above information is based on the data of which we are aware and is believed to be correct as of the date hereof. Since this information may be applied under conditions beyond our control and with which we may be unfamiliar and since data made available subsequent to the date hereof may suggest modifications of the information, we do not assume any responsibility for the results of its use. This information is furnished upon condition that the person receiving it shall make his own determination of the suitability of the material for his particular purpose.

2900HS BATTERY MATERIAL SAFETY DATA

MATERIAL SAFETY DATA SHEET

Product Identity: Valve Regulated Lead Acid Battery

1. HAZARDOUS COMPONENTS

Components	% Weight	TLV	LD50 Oral	LC50 Inhalation	LC50 Contact
Lead (Pb,PbO□PbSO)	about 70%	N/A	(500)mg/kg	N/A	N/A
Sulfuric Acid	about 20%	1mg/m ³	(2.140)mg/kg	N/A	N/A
Fiber Glass Separat	about 2%	N/A	N/A	N/A	N/A
ABS (Case & Cover	about 8%	N/A	N/A	N/A	N/A

2. PHYSICAL DATA

Components	Density	Melting Point	Solubility (H□O)	Odor	Appearance
Lead	11.34	327.4°C (Boiling)	None	None	Siler-Grey Metal
Lead Sulfate	6.2	1070°C (Boiling)	40mg/l (15°C)	None	White Powder
Lead Dioxide	9.4	290°C (Boiling)	None	None	Brown Powder
Sulfuric Acid	about 1.3	about 114°C (Boiling)	100%	Acidic	Clear Colorless Liquid
Fiber Glass Separat	N/A	N/A	Slight	Toxic	White Fibrous Glass
ABS (Case & Cover	N/A	N/A	None	None	Solid

3. FLAMMABILITY DATA

Components	Flash Point	Explosive Limits	Comments
Lead	None	None	
Sulfuric Acid	None	None	
Hydrogen	-	4%-74.2%	Sealed batteries can emit hydrogen only if overcharged (float voltage>2.3vpc 25°C)
Fiber Glass Separator	N/A	N/A	Toxic vapor may be released. In case of fire; wear self-contained breathing apparatus
ABS	None	N/A	Temperature over 200°C may release gases

4. FIRST AID: Sulfuric Acid Precautions

Inhalation	Move to ventilated area. Obtain medical attention
Eyes	Wash the eyes with copious quantities of running water for 15 minutes. Obtain medical attention
Skin	Flush area with large amounts of running water. Remove contaminated clothing and obtain medical attention
Ingestion	Wash out mouth with running water. Do not induce vomiting. Call Physician.

MSDS, January 2008

2900HS BATTERY MATERIAL SAFETY DATA

5. REACTIVITY DATA

Component	Sulfuric Acid
Stability	Stable at all temperatures
Polymerization	Will not polymerize
Incompatibility	Reactive metals, strong bases, most organic compounds
Decomposition products	Sulfuric dioxide, trioxide, hydrogen sulfide, hydrogen
Conditions to avoid	Keep away from flames during and immediately after charging. Combustion or overcharging may create or liberate toxic and hazardous gases and liquid including hydrogen, sulfuric acid mist, sulfur dioxide, sulfur trioxide and sulfuric acid Avoid mixing acid with other chemicals

6. SPILL OR LEAK PROCEDURES

Step to take in case of leak or spill	Wear protective clothing, Ventilate enclosed areas. Dike to contain contaminated material and liquids. Limit site access to emergency responses. Neutralize with sodium bicarbonate, soda ash, lime, and other neutralizing agents.
Waste disposal method	Return whole scrap batteries to distributor, manufacturer or lead smelter for recycling. For neutralized spills, place residue into containers with absorbent material, sand or earth for disposal. Contact local and/or state environmental officials for proper disposal requirements.

7. PROTECTION

Exposure site	Protection	Comments
Skin	Rubber Gloves, Apron	Protective equipment must be worn if the battery is cracked or damaged. A respirator should be worn during certain operations if the TLV is exceeded.
Respiratory	Respirator	
Eyes	Safety Goggles, Face shield	

8. ELECTRICAL SAFETY

Due to battery's low internal resistance and high power density, high level of short circuit current could be developed across the battery terminals. Do not rest tools or cables on the battery. Use the insulated tools only. Follow all installation instructions and diagram when installing or maintaining battery systems.

9. HEALTH HAZARD DATA

Lead	The toxic effects of lead are accumulated and slow to appear. It affects the kidneys, reproductive and central nerves system. The Symptoms of Lead overexposure are vomiting, headaches, stomach pain, Exposure to lead from a battery most often occurs during lead reclaim operations through the breathing or ingestion of lead dust or fumes. THIS DATA MUST BE PASSED TO ANY SCRAP DEALER OR SMELTER WHEN A BATTERY IS RESOLD.
Sulfuric Acid	Sulfuric Acid is a strong corrosive; contact with acid can cause severe burns on the skin and eyes. Acid can be released if the battery case is damaged.

2900HS GUARANTEE

National Flooring Equipment, Inc. (National) warrants to the first consumer/purchaser that this National brand product (the #2900HS Panther® - High Speed - Floor Prep System), when shipped in its original container, will be free from defective workmanship and materials and agrees that it will, at its option, either repair the defect or replace the defective product or part thereof at no charge to the purchaser for parts or labor for the period(s) set forth below.

This warranty does not apply to any appearance items of the product, to the additional excluded items set forth below, or to any product, the exterior of which has been damaged or defaced, which has been subjected to misuse, abnormal service or handling, or which has been altered or modified in design or construction.

In order to enforce the rights under this limited warranty, the purchaser should follow the steps set forth below and provide proof of purchase to National.

The limited warranty described herein is in addition to whatever implied warranties may be granted to purchasers by law. ALL IMPLIED WARRANTIES INCLUDING THE WARRANTIES OF MERCHANTABILITY AND FITNESS FOR USE ARE LIMITED TO THE PERIODS FROM THE DATE OF PURCHASE AS SET FORTH BELOW. Some states do not allow time limitations on an implied warranty, so the above limitation may not apply to you.

Neither the sales person of the seller, nor any other person, is authorized to make any other warranties other than those described herein, or to extend the duration of any warranties beyond the time period described herein on behalf of National.

The warranties described herein shall be the sole and exclusive warranties granted by National and shall be the sole and exclusive remedy available to the purchaser. Correction of defects in the manner and for the period of time described herein, shall constitute complete fulfillment of all liabilities and responsibilities of National to the purchaser with respect to the product and shall constitute full satisfaction of all claims, whether based on contract, negligence, strict liability or otherwise. In no event shall National be liable, or in any way responsible for any damage or defects in the product which were caused by repairs or attempted repairs performed by anyone other than National. Nor shall National be liable, or in any way responsible, for any incidental or consequential, economics or property damage. Some states do not allow the exclusion of incidental or consequential damages, so the above exclusion may not apply to you.

THIS WARRANTY GIVES YOU SPECIFIC LEGAL RIGHTS. YOU MAY ALSO HAVE OTHER RIGHTS WHICH VARY FROM STATE TO STATE.

WARRANTY PERIOD

The #2900HS Panther® - High Speed - Floor Prep System is guaranteed to be free of manufacturer defective workmanship and in quality of materials for a period of one year.

Items excluded from warranty coverage, unless found and reported defective immediately upon removal from the original shipping container and before being used by the original purchaser.

A freight damage claim must be filed with the carrier by the purchaser, the shipper cannot file the freight claim.

To obtain service contact National Flooring Equipment, Inc. toll free at 800-245-0267 for a repair authorization number. COD freight returns will not be accepted. Freight collect shipments will not be accepted. Warranty repairs must be accompanied by date of purchase receipt and a return/repair authorization number.

2900HS RETURN SHEET

Company Name _____

Contact Name _____

Telephone Number _____

Approximate Usage (hours) _____

Problems Encountered _____

Check One: Repair

Do you wish to be contacted before repairing Yes No

Return

Contact National if a loaner is needed

Return Authorization Number _____ Date _____
required, contact National

Customer Number _____
if known

Purchased From _____
if not directly from National

INTERNAL USE ONLY

Date Received _____

Unit Serial Number _____

Subject To Warranty _____

2900HS BLADE ORDER FORM

Part #	Description	Thickness	Quantity
#135	5" x 16" Blade	.062	
#147	4" x 6" Blade	.062	
#148	5" x 6" Blade	.062	
#363-2	3/4" x 8" Razor/Scraper Blade (50/pkg)	.032	
#368-8	7/8" x 8" Razor/Scraper Blade (50/pkg)	.045	
#368-12	7/8" x 12" Razor/Scraper Blade (50/pkg)	.045	
#368-15	7/8" x 15" Razor/Scraper Blade (50/pkg)	.045	
#6258-BU	3" x 12" Self-Scoring Blade - Bevel Up	.062	
#6259-BU	3" x 14" Self-Scoring Blade - Bevel Up	.062	
#6260-BD	3" x 6" Heavy Duty Ditching	.094	
#6276-BU	3" x 10" Self-Scoring Blade	.094	
#6277-BU	3" x 12" Self-Scoring Blade	.094	
#6278-BU	3" x 14" Self-Scoring Blade	.094	
#6281	3" x 8" Heavy Duty Blade	.094	
#6282	3" x 14" Heavy Duty Blade	.094	
#6283	3" x 27" Heavy Duty Blade	.094	
#6284	3" x 12" Heavy Duty Blade	.094	
#6285	3" x 6" Heavy Duty Blade	.094	
#6286	3" x 10" Heavy Duty Blade	.094	
#6290	3" x 6" Extra Heavy Duty Blade	.187	
#6291	3" x 8" Extra Heavy Duty Blade	.187	
#6292	3" x 12" Extra Heavy Duty Blade	.187	
#6293	3" x 14" Extra Heavy Duty Blade	.187	
#6294	3" x 27" Extra Heavy Duty Blade	.187	
#7050-200	3" x 6" Premium High Tempered Blade	.062	
#7050-201	3" x 8" Premium High Tempered Blade	.062	
#7050-202	3" x 10" Premium High Tempered Blade	.062	
#7050-203	3" x 12" Premium High Tempered Blade	.062	
#7050-204	3" x 14" Premium High Tempered Blade	.062	
#7050-205	3" x 27" Premium High Tempered Blade	.062	
#7070-2	4" x 2" Straight Shank Blades	.500	
#7070-3	4" x 3" Straight Shank Blades	.500	
#7070-4	4" x 4" Straight Shank Blades	.500	
#7070-6	4" x 6" Straight Shank Blades	.500	
#7071-2	4" x 2" Angle Shank Blades	.500	
#7071-3	4" x 3" Angle Shank Blades	.500	
#7071-4	4" x 4" Angle Shank Blades	.500	
#7071-6	4" x 6" Angle Shank Blades	.500	
#7072-2	4" x 2" Straight Shank w/Carbide Tip	.500	
#7072-3	4" x 3" Straight Shank w/Carbide Tip	.500	
#7072-4	4" x 4" Straight Shank w/Carbide Tip	.500	
#7072-6	4" x 6" Straight Shank w/Carbide Tip	.500	

2900HS BLADE ORDER FORM

Part #	Description	Thickness	Quantity
#7074	5" x 27" Tile Box with 6" High Box	.187	
#7075-8	2" x 8" Tapered Cutting Head Shank	.300	
#7075-11	2" x 11" Tapered Cutting Head Shank	.300	
#7077-8	3.5" x 8" Tapered Cutting Head Shank	.300	
#7077-11	3.5" x 11" Tapered Cutting Head Shank	.300	
#7076-8	2" x 8" Tapered w/Carbide Tip	.300	
#7076-11	2" x 11" Tapered w/Carbide Tip	.300	
#7078-8	3.5" x 8" Tapered w/Carbide Tip	.300	
#7078-11	3.5" x 11" Tapered w/Carbide Tip	.300	
#7079-2	2" x 6" Ultra HD Ceramic Epoxy Blade	.500	
#7079-4	4" x 6" Ultra HD Ceramic Epoxy Blade	.500	
#7079-6	6" x 6" Ultra HD Ceramic Epoxy Blade	.500	
#7081	3" x 10" Increased Angle Blade	.062	
#7083	3" x 8" Increased Angle Blade	.062	

BILL TO:

Attn: _____

Company: _____

Address: _____

Phone: _____

SHIP TO:

Attn: _____

Company: _____

Address: _____

Phone: _____

TO ORDER:

Phone: 800-245-0267 or 763-535-8206

Fax: 800-648-7124 or 763-535-8255

Online: www.nationalequipment.com

All orders and payment terms to be verified prior to shipping.

National Flooring Equipment, Inc. • 9250 Xylon Avenue North • Minneapolis, MN 55445 U.S.A.

Phone 800-245-0267 or 763-535-8206 • Fax 800-648-7124 or 763-535-8255

Web Site: www.nationalequipment.com • E-Mail: info@nationalequipment.com