



DESCO TOOLS

2014 Catalog



**Industrial Quality
Drills, Taps, Dies, Screw Extractors
and Related Cutting Tools**



DESCO TOOLS

965 South Meridian Avenue
Alhambra, CA 91803
(626) 291-5970
www.descotools.com

Dear DescoTools Customer,

For over 25 years DescoTools has specialized in providing professional grade cutting and hand tools specially engineered for industrial applications.

Our products are backed by our guarantee of satisfaction and we consider it our mission to provide the highest level of service and support to our customers.

We ship in stock products the same day if ordered by 3 P.M. California time.

We have expanded our ordering process to better serve you. Orders can be placed by one of the following three methods:

- Order by phone at (626) 291-5970
- Order by fax to (626) 291-5975
- Order by email to orders@descotools.com

At DescoTools we are committed to providing you with top quality products, competitive pricing and outstanding service.

We appreciate your business and value your loyalty.

Sincerely yours,

Jamie Halimi
President, DescoTools

Table of Contents



Drills

Jobbers Length Drills

Fractional Sizes

| | |
|--------------------------------|---|
| Heavy Duty Black..... | 1 |
| Super Duty Black and Gold..... | 1 |
| Titanium..... | 2 |
| Cobalt..... | 2 |
| Bright..... | 3 |
| Black..... | 3 |
| Left Hand Bright..... | 4 |

Wire Gage Sizes

| | |
|--------------------------------|---|
| Heavy Duty Black..... | 5 |
| Super Duty Black and Gold..... | 6 |
| Cobalt..... | 7 |
| Bright..... | 8 |
| Black..... | 9 |

Metric Sizes.....

Letter Sizes

| | |
|-----------------------|----|
| Heavy Duty Black..... | 11 |
| Cobalt..... | 11 |
| Bright..... | 12 |
| Black..... | 12 |

3/8 Reduced Shank Drills

| | |
|--------------------------------|----|
| Heavy Duty Black..... | 13 |
| Titanium..... | 13 |
| Cobalt..... | 13 |
| Super Duty Black and Gold..... | 14 |
| Bright..... | 14 |
| Black..... | 14 |

1/2 Reduced Shank Drills

| | |
|--------------------|----|
| Bronze Finish..... | 15 |
| Cobalt..... | 15 |
| Black Finish..... | 16 |

1/4 Reduced Shank Drills

| | |
|-------------|----|
| Bright..... | 17 |
| Black..... | 17 |

12" & 18" Long Drills.....

| | |
|---|----|
| 6" Aircraft Extension Drills..... | 19 |
| 12" Aircraft Extension Drills..... | 20 |
| Screw Machine (Stub Length Drills)..... | 21 |

Masonry Drills

| | |
|-----------------------------------|----|
| Slow Spiral Bright..... | 23 |
| Fast Spiral Bright..... | 23 |
| Slow Spiral Heavy Duty Black..... | 24 |
| SDS Plus..... | 24 |
| 13" Carbide Tipped..... | 25 |
| "A" Taper Percussion Drills..... | 25 |
| 18" Carbide Tipped..... | 26 |
| Rotary Hammer..... | 26 |
| Concrete Screw Anchor Bits..... | 26 |

Specialty Drills

| | |
|---------------------------------------|----|
| Combined Drills and Countersinks..... | 27 |
| Glass & Tile..... | 28 |
| Double-End Drills..... | 28 |
| Carbide Tipped..... | 28 |
| Wood Cutting Twist Drills..... | 29 |
| Forstner Bits..... | 29 |
| Self-Feed Bits..... | 29 |
| Drills For Plastics (Plexiglass)..... | 30 |

Drill Sets.....



Screw Extractors

| | |
|--------------------------------|-------|
| Left Hand Spiral Flutes..... | 37 |
| Left Hand Straight Flutes..... | 38 |
| Screw Extractor Sets..... | 37-38 |



Carbon Steel Taps

| | |
|-----------------------|----|
| Fractional Sizes..... | 39 |
| Machine Screw..... | 40 |
| Pipe Taps..... | 41 |
| Left Hand Taps..... | 41 |
| Metric Sizes..... | 42 |

High Speed Steel Taps

| | |
|--------------------------|----|
| Machine..... | 43 |
| Fractional..... | 43 |
| Spiral..... | 44 |
| National Pipe Taper..... | 44 |

High Speed Steel Ground Thread Taps

| | |
|---|----|
| Machine Screw Sizes..... | 45 |
| Fractional Sizes..... | 47 |
| Spiral Point (Chip Driver)..... | 49 |
| Spiral Fluted..... | 51 |
| Fast Spiral Fluted..... | 51 |
| Fluteless Spiral Point (Chip Driver)..... | 52 |
| Pulley Taps..... | 53 |
| Nut Taps..... | 53 |
| Taper Pipe Taps..... | 54 |
| Straight Pipe Taps..... | 55 |
| Left Hand Style..... | 55 |
| Metric..... | 56 |
| Spiral Point Metric Plug Taps..... | 57 |

High Speed Steel Combined Taps and Drills

| | |
|-----------------------------|----|
| Right Hand Style..... | 57 |
| Combined Tap and Drill..... | 58 |



Carbon Steel Round Dies

- Solid and Screw Adjusting
 - Machine Screw..... 59
 - Fractional..... 60
- High Speed Steel Round Dies
 - Screw Adjusting
 - Machine Screw Sizes..... 61
 - Fractional Sizes..... 61
 - Metric..... 62



Carbon Steel Hex Dies

- Machine Screw..... 63
- Fractional..... 63
- Metric..... 64

Carbon Steel Hex Retreading Dies

- Fractional Sizes..... 65
- Metric Sizes..... 65
- NPT Pipe Sizes..... 66

Tap and Die Sets..... 67-72



Tap Wrenches and Die Stocks

- Adjustable Handle Tap and Reamer Wrenches..... 73
- Offset Handle Tap and Reamer Wrenches..... 73
- Sliding T-Handle Tap Wrenches..... 73
- 3 Jaw Adjustable Die Stocks for Hex Dies..... 74
- Plain Die Stocks for Hex Dies..... 74
- 3 Jaw Adjustable Die Stocks for Round Dies..... 74
- Plain Die Stocks for Round Dies..... 74



Reamers and Countersinks

- Countersinks..... 75
- T-Handle Repairman's Reamers..... 76
- Repairman's Reamer..... 76
- Burring Reamer with 1/2" Round Shank..... 76



Hole Saws & Accessories..... 77

Bi-Metal Hole Saw Kits..... 78



Steel Stamp Sets

- Numeral Sets..... 79
- Letter Sets..... 79
- Low Stress..... 80
- Positive Identification..... 80
- Reversed..... 80



Files..... 81-82



Reciprocating Saw Blades..... 83-84

Jig Saw Blade Sets..... 84



Hex Key Wrenches..... 85-86

Ball End L-Wrenches..... 87

Hex Key Wrench Sets..... 87

Miscellaneous Tools

- Thread Gauges for Inch and Metric Screws..... 88
- Screw Pitch Gauges..... 88
- 13 Piece Drill and Tap Set..... 88

Jobbers Length Drills

Fractional Sizes · High Performance

Features

- 135° Split Point
- Surface Treated
- Straight Shank
- 10 per pack 1/4" and smaller
- High Speed Steel
- 5 per pack 17/64" and larger

Heavy Duty Black



| Size | Dec. Equiv | Overall Length | Product Number | |
|-------|------------|----------------|----------------|--------|
| | | | Bulk | Carded |
| 1/16" | .0625" | 1-7/8" | 30604 | 37904 |
| 5/64 | .0781 | 2 | 30605 | 37905 |
| 3/32 | .0938 | 2-1/4 | 30606 | 37906 |
| 7/64 | .1094 | 2-5/8 | 30607 | 37907 |
| 1/8 | .1250 | 2-3/4 | 30608 | 37908 |
| 9/64 | .1406 | 2-7/8 | 30609 | 37909 |
| 5/32 | .1562 | 3-1/8 | 30610 | 37910 |
| 11/64 | .1719 | 3-1/4 | 30611 | 37911 |
| 3/16 | .1875 | 3-1/2 | 30612 | 37912 |
| 13/64 | .2031 | 3-5/8 | 30613 | 37913 |
| 7/32 | .2188 | 3-3/4 | 30614 | 37914 |
| 15/64 | .2344 | 3-7/8 | 30615 | 37915 |
| 1/4 | .2500 | 4 | 30616 | 37916 |
| 17/64 | .2656 | 4-1/8 | 30617 | 37917 |
| 9/32 | .2812 | 4-1/4 | 30618 | 37918 |

| Size | Dec. Equiv | Overall Length | Product Number | |
|--------|------------|----------------|----------------|--------|
| | | | Bulk | Carded |
| 19/64" | .2969" | 4-3/8" | 30619 | 37919 |
| 5/16 | .3125 | 4-1/2 | 30620 | 37920 |
| 21/64 | .3281 | 4-5/8 | 30621 | 37921 |
| 11/32 | .3438 | 4-3/4 | 30622 | 37922 |
| 23/64 | .3594 | 4-7/8 | 30623 | 37923 |
| 3/8 | .3750 | 5 | 30624 | 37924 |
| 25/64 | .3906 | 5-1/8 | 30625 | 37925 |
| 13/32 | .4062 | 5-1/4 | 30626 | 37926 |
| 27/64 | .4219 | 5-3/8 | 30627 | 37927 |
| 7/16 | .4375 | 5-1/2 | 30628 | 37928 |
| 29/64 | .4531 | 5-5/8 | 30629 | 37929 |
| 15/32 | .4688 | 5-3/4 | 30630 | 37930 |
| 31/64 | .4844 | 5-7/8 | 30631 | 37931 |
| 1/2 | .5000 | 6 | 30632 | 37932 |

Jobbers Length Drills

Fractional Sizes · High Performance

Features

- 135° Split Point
- Surface Treated
- Straight Shank
- 10 per pack 1/4" and smaller
- High Speed Steel
- 5 per pack 17/64" and larger

Super Duty Black and Gold



| Size | Dec. Equiv | Overall Length | Product Number | |
|-------|------------|----------------|----------------|--------|
| | | | Bulk | Carded |
| 1/16" | .0625" | 1-7/8" | 36204 | 37304 |
| 5/64 | .0781 | 2 | 36205 | 37305 |
| 3/32 | .0938 | 2-1/4 | 36206 | 37306 |
| 7/64 | .1094 | 2-5/8 | 36207 | 37307 |
| 1/8 | .1250 | 2-3/4 | 36208 | 37308 |
| 9/64 | .1406 | 2-7/8 | 36209 | 37309 |
| 5/32 | .1562 | 3-1/8 | 36210 | 37310 |
| 11/64 | .1719 | 3-1/4 | 36211 | 37311 |
| 3/16 | .1875 | 3-1/2 | 36212 | 37312 |
| 13/64 | .2031 | 3-5/8 | 36213 | 37313 |
| 7/32 | .2188 | 3-3/4 | 36214 | 37314 |
| 15/64 | .2344 | 3-7/8 | 36215 | 37315 |
| 1/4 | .2500 | 4 | 36216 | 37316 |
| 17/64 | .2656 | 4-1/8 | 36217 | 37317 |
| 9/32 | .2812 | 4-1/4 | 36218 | 37318 |

| Size | Dec. Equiv | Overall Length | Product Number | |
|--------|------------|----------------|----------------|--------|
| | | | Bulk | Carded |
| 19/64" | .2969" | 4-3/8" | 36219 | 37319 |
| 5/16 | .3125 | 4-1/2 | 36220 | 37320 |
| 21/64 | .3281 | 4-5/8 | 36221 | 37321 |
| 11/32 | .3438 | 4-3/4 | 36222 | 37322 |
| 23/64 | .3594 | 4-7/8 | 36223 | 37323 |
| 3/8 | .3750 | 5 | 36224 | 37324 |
| 25/64 | .3906 | 5-1/8 | 36225 | 37325 |
| 13/32 | .4062 | 5-1/4 | 36226 | 37326 |
| 27/64 | .4219 | 5-3/8 | 36227 | 37327 |
| 7/16 | .4375 | 5-1/2 | 36228 | 37328 |
| 29/64 | .4531 | 5-5/8 | 36229 | 37329 |
| 15/32 | .4688 | 5-3/4 | 36230 | 37330 |
| 31/64 | .4844 | 5-7/8 | 36231 | 37331 |
| 1/2 | .5000 | 6 | 36232 | 37332 |

Features

- 135° Split Point
- Titanium Nitride Coating
- Straight Shank
- 10 per pack 1/4" and smaller
- High Speed Steel
- 5 per pack 17/64" and larger

Titanium



| Size | Dec. Equiv | Overall Length | Product Number | |
|-------|------------|----------------|----------------|--------|
| | | | Bulk | Carded |
| 1/16" | .0625" | 1-7/8" | 36504 | 37504 |
| 5/64 | .0781 | 2 | 36505 | 37506 |
| 3/32 | .0938 | 2-1/4 | 36506 | 37507 |
| 7/64 | .1094 | 2-5/8 | 36507 | 37508 |
| 1/8 | .1250 | 2-3/4 | 36508 | 37509 |
| 9/64 | .1406 | 2-7/8 | 36509 | 37510 |
| 5/32 | .1562 | 3-1/8 | 36510 | 37511 |
| 11/64 | .1719 | 3-1/4 | 36511 | 37512 |
| 3/16 | .1875 | 3-1/2 | 36512 | 37513 |
| 13/64 | .2031 | 3-5/8 | 36513 | 37514 |
| 7/32 | .2188 | 3-3/4 | 36514 | 37515 |
| 15/64 | .2344 | 3-7/8 | 36515 | 37516 |
| 1/4 | .2500 | 4 | 36516 | 37517 |
| 17/64 | .2656 | 4-1/8 | 36517 | 37518 |
| 9/32 | .2812 | 4-1/4 | 36518 | 37519 |

| Size | Dec. Equiv | Overall Length | Product Number | |
|--------|------------|----------------|----------------|--------|
| | | | Bulk | Carded |
| 19/64" | .2969" | 4-3/8" | 36519 | 37520 |
| 5/16 | .3125 | 4-1/2 | 36520 | 37521 |
| 21/64 | .3281 | 4-5/8 | 36521 | 37522 |
| 11/32 | .3438 | 4-3/4 | 36522 | 37523 |
| 23/64 | .3594 | 4-7/8 | 36523 | 37524 |
| 3/8 | .3750 | 5 | 36524 | 37525 |
| 25/64 | .3906 | 5-1/8 | 36525 | 37526 |
| 13/32 | .4062 | 5-1/4 | 36526 | 37527 |
| 27/64 | .4219 | 5-3/8 | 36527 | 37528 |
| 7/16 | .4375 | 5-1/2 | 36528 | 37529 |
| 29/64 | .4531 | 5-5/8 | 36529 | 37530 |
| 15/32 | .4688 | 5-3/4 | 36530 | 37531 |
| 31/64 | .4844 | 5-7/8 | 36531 | 37532 |
| 1/2 | .5000 | 6 | 36532 | 37533 |

Features

- 135° Split Point
- Heat Resistant Cobalt
- Straight Shank
- 10 per pack 1/4" and smaller
- High Speed Steel
- 5 per pack 17/64" and larger

Cobalt



| Size | Dec. Equiv | Overall Length | Product Number | |
|-------|------------|----------------|----------------|--------|
| | | | Bulk | Carded |
| 1/16" | .0625" | 1-7/8" | 38704 | 37704 |
| 5/64 | .0781 | 2 | 38705 | 37705 |
| 3/32 | .0938 | 2-1/4 | 38706 | 37706 |
| 7/64 | .1094 | 2-5/8 | 38707 | 37707 |
| 1/8 | .1250 | 2-3/4 | 38708 | 37708 |
| 9/64 | .1406 | 2-7/8 | 38709 | 37709 |
| 5/32 | .1562 | 3-1/8 | 38710 | 37710 |
| 11/64 | .1719 | 3-1/4 | 38711 | 37711 |
| 3/16 | .1875 | 3-1/2 | 38712 | 37712 |
| 13/64 | .2031 | 3-5/8 | 38713 | 37713 |
| 7/32 | .2188 | 3-3/4 | 38714 | 37714 |
| 15/64 | .2344 | 3-7/8 | 38715 | 37715 |
| 1/4 | .2500 | 4 | 38716 | 37716 |
| 17/64 | .2656 | 4-1/8 | 38717 | 37717 |
| 9/32 | .2812 | 4-1/4 | 38718 | 37718 |

| Size | Dec. Equiv | Overall Length | Product Number | |
|--------|------------|----------------|----------------|--------|
| | | | Bulk | Carded |
| 19/64" | .2969" | 4-3/8" | 38719 | 37719 |
| 5/16 | .3125 | 4-1/2 | 38720 | 37720 |
| 21/64 | .3281 | 4-5/8 | 38721 | 37721 |
| 11/32 | .3438 | 4-3/4 | 38722 | 37722 |
| 23/64 | .3594 | 4-7/8 | 38723 | 37723 |
| 3/8 | .3750 | 5 | 38724 | 37724 |
| 25/64 | .3906 | 5-1/8 | 38725 | 37725 |
| 13/32 | .4062 | 5-1/4 | 38726 | 37726 |
| 27/64 | .4219 | 5-3/8 | 38727 | 37727 |
| 7/16 | .4375 | 5-1/2 | 38728 | 37728 |
| 29/64 | .4531 | 5-5/8 | 38729 | 37729 |
| 15/32 | .4688 | 5-3/4 | 38730 | 37730 |
| 31/64 | .4844 | 5-7/8 | 38731 | 37731 |
| 1/2 | .5000 | 6 | 38732 | 37732 |



Jobbers Length Drills

Fractional Sizes

Features

- 118° Split Point
- Straight Shank
- High Speed Steel
- Highly Polished Flute
- 10 per pack 1/4" and smaller
- 5 per pack 17/64" and larger

Bright



| Size | Dec. Equiv | Overall Length | Product Number | |
|-------|------------|----------------|----------------|--------|
| | | | Bulk | Carded |
| 1/64" | .0156" | 3/4" | 31001 | - |
| 1/32 | .0313 | 1-3/8 | 31002 | - |
| 3/64 | .0469 | 1-3/4 | 31003 | - |
| 1/16 | .0625 | 1-7/8 | 31004 | 38104 |
| 5/64 | .0781 | 2 | 31005 | 38105 |
| 3/32 | .0938 | 2-1/4 | 31006 | 38106 |
| 7/64 | .1094 | 2-5/8 | 31007 | 38107 |
| 1/8 | .1250 | 2-3/4 | 31008 | 38108 |
| 9/64 | .1406 | 2-7/8 | 31009 | 38109 |
| 5/32 | .1562 | 3-1/8 | 31010 | 38110 |
| 11/64 | .1719 | 3-1/4 | 31011 | 38111 |
| 3/16 | .1875 | 3-1/2 | 31012 | 38112 |
| 13/64 | .2031 | 3-5/8 | 31013 | 38113 |
| 7/32 | .2188 | 3-3/4 | 31014 | 38114 |
| 15/64 | .2344 | 3-7/8 | 31015 | 38115 |
| 1/4 | .2500 | 4 | 31016 | 38116 |

| Size | Dec. Equiv | Overall Length | Product Number | |
|--------|------------|----------------|----------------|--------|
| | | | Bulk | Carded |
| 17/64" | .2656" | 4-1/8" | 31017 | 38117 |
| 9/32 | .2812 | 4-1/4 | 31018 | 38118 |
| 19/64 | .2969 | 4-3/8 | 31019 | 38119 |
| 5/16 | .3125 | 4-1/2 | 31020 | 38120 |
| 21/64 | .3281 | 4-5/8 | 31021 | 38121 |
| 11/32 | .3438 | 4-3/4 | 31022 | 38122 |
| 23/64 | .3594 | 4-7/8 | 31023 | 38123 |
| 3/8 | .3750 | 5 | 31024 | 38124 |
| 25/64 | .3906 | 5-1/8 | 31025 | 38125 |
| 13/32 | .4062 | 5-1/4 | 31026 | 38126 |
| 27/64 | .4219 | 5-3/8 | 31027 | 38127 |
| 7/16 | .4375 | 5-1/2 | 31028 | 38128 |
| 29/64 | .4531 | 5-5/8 | 31029 | 38129 |
| 15/32 | .4688 | 5-3/4 | 31030 | 38130 |
| 31/64 | .4844 | 5-7/8 | 31031 | 38131 |
| 1/2 | .5000 | 6 | 31032 | 38132 |

Jobbers Length Drills

Fractional Sizes

Features

- 118° Split Point
- Straight Shank
- High Speed Steel
- Surface Treated
- 10 per pack 1/4" and smaller
- 5 per pack 17/64" and larger

Black



| Size | Dec. Equiv | Overall Length | Product Number Bulk |
|-------|------------|----------------|---------------------|
| 1/64" | .0156" | 3/4" | 36101 |
| 1/32 | .0313 | 1-3/8 | 36102 |
| 3/64 | .0469 | 1-3/4 | 36103 |
| 1/16 | .0625 | 1-7/8 | 36104 |
| 5/64 | .0781 | 2 | 36105 |
| 3/32 | .0938 | 2-1/4 | 36106 |
| 7/64 | .1094 | 2-5/8 | 36107 |
| 1/8 | .1250 | 2-3/4 | 36108 |
| 9/64 | .1406 | 2-7/8 | 36109 |
| 5/32 | .1562 | 3-1/8 | 36110 |
| 11/64 | .1719 | 3-1/4 | 36111 |
| 3/16 | .1875 | 3-1/2 | 36112 |
| 13/64 | .2031 | 3-5/8 | 36113 |
| 7/32 | .2188 | 3-3/4 | 36114 |
| 15/64 | .2344 | 3-7/8 | 36115 |
| 1/4 | .2500 | 4 | 36116 |

| Size | Dec. Equiv | Overall Length | Product Number Bulk |
|--------|------------|----------------|---------------------|
| 17/64" | .2656" | 4-1/8" | 36117 |
| 9/32 | .2812 | 4-1/4 | 36118 |
| 19/64 | .2969 | 4-3/8 | 36119 |
| 5/16 | .3125 | 4-1/2 | 36120 |
| 21/64 | .3281 | 4-5/8 | 36121 |
| 11/32 | .3438 | 4-3/4 | 36122 |
| 23/64 | .3594 | 4-7/8 | 36123 |
| 3/8 | .3750 | 5 | 36124 |
| 25/64 | .3906 | 5-1/8 | 36125 |
| 13/32 | .4062 | 5-1/4 | 36126 |
| 27/64 | .4219 | 5-3/8 | 36127 |
| 7/16 | .4375 | 5-1/2 | 36128 |
| 29/64 | .4531 | 5-5/8 | 36129 |
| 15/32 | .4688 | 5-3/4 | 36130 |
| 31/64 | .4844 | 5-7/8 | 36131 |
| 1/2 | .5000 | 6 | 36132 |

Features

- 118° Split Point
- Highly Polished Flute
- Straight Shank
- 10 per pack 1/4" and smaller
- High Speed Steel
- 5 per pack 17/64" and larger

Left Hand Bright



| Size | Dec. Equiv | Overall Length | Product Number Bulk | Carded |
|-------|------------|----------------|---------------------|--------|
| 1/64" | .0156" | 3/4" | - | - |
| 1/32 | .0313 | 1-3/8 | - | - |
| 3/64 | .0469 | 1-3/4 | - | - |
| 1/16 | .0625 | 1-7/8 | 31004L | 39904 |
| 5/64 | .0781 | 2 | 31005L | 39905 |
| 3/32 | .0938 | 2-1/4 | 31006L | 39906 |
| 7/64 | .1094 | 2-5/8 | 31007L | 39907 |
| 1/8 | .1250 | 2-3/4 | 31008L | 39908 |
| 9/64 | .1406 | 2-7/8 | 31009L | 39909 |
| 5/32 | .1562 | 3-1/8 | 31010L | 39910 |
| 11/64 | .1719 | 3-1/4 | 31011L | 39911 |
| 3/16 | .1875 | 3-1/2 | 31012L | 39912 |
| 13/64 | .2031 | 3-5/8 | 31013L | 39913 |
| 7/32 | .2188 | 3-3/4 | 31014L | 39914 |
| 15/64 | .2344 | 3-7/8 | 31015L | 39915 |
| 1/4 | .2500 | 4 | 31016L | 39916 |

| Size | Dec. Equiv | Overall Length | Product Number Bulk | Carded |
|--------|------------|----------------|---------------------|--------|
| 17/64" | .2656" | 4-1/8" | 31017L | 39917 |
| 9/32 | .2812 | 4-1/4 | 31018L | 39918 |
| 19/64 | .2969 | 4-3/8 | 31019L | 39919 |
| 5/16 | .3125 | 4-1/2 | 31020L | 39920 |
| 21/64 | .3281 | 4-5/8 | 31021L | 39921 |
| 11/32 | .3438 | 4-3/4 | 31022L | 39922 |
| 23/64 | .3594 | 4-7/8 | 31023L | 39923 |
| 3/8 | .3750 | 5 | 31024L | 39924 |
| 25/64 | .3906 | 5-1/8 | 31025L | 39925 |
| 13/32 | .4062 | 5-1/4 | 31026L | 39926 |
| 27/64 | .4219 | 5-3/8 | 31027L | 39927 |
| 7/16 | .4375 | 5-1/2 | 31028L | 39928 |
| 29/64 | .4531 | 5-5/8 | 31029L | 39929 |
| 15/32 | .4688 | 5-3/4 | 31030L | 39930 |
| 31/64 | .4844 | 5-7/8 | 31031L | 39931 |
| 1/2 | .5000 | 6 | 31032L | 39932 |

Technical Information

Drill Size Chart

The following chart shows the approximate range of sizes that are covered by each category of drills on pages 1 through 17.

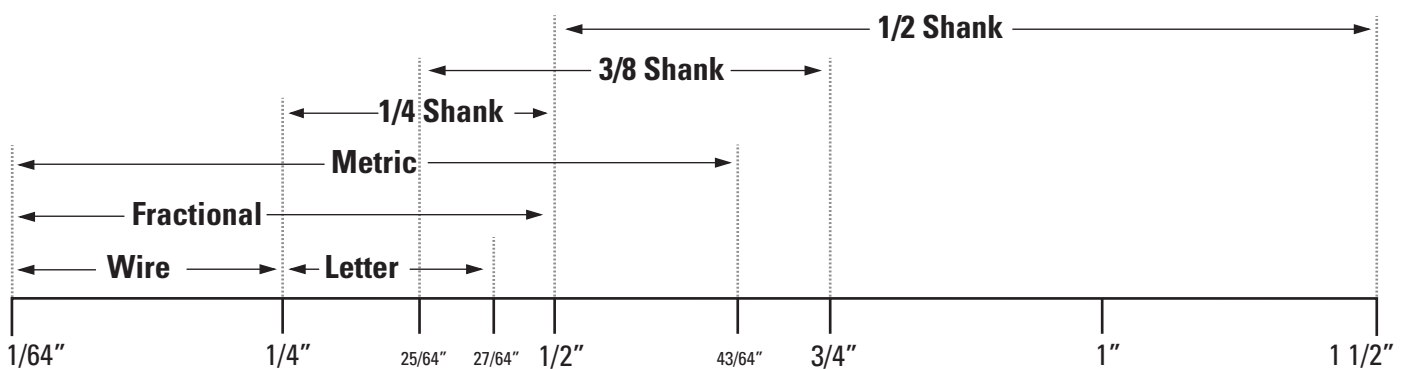

Jobbers Length Drills

Wire Gage Sizes · High Performance

Features

- 135° Split Point
- No. 52 & Smaller 118° Split Point
- Straight Shank
- Surface Treated
- High Speed Steel
- 5 per pack

Heavy Duty Black



| Size | Dec. Equiv | Overall Length | Product Number Bulk |
|------|------------|----------------|---------------------|
| 1 | .2280" | 3-7/8" | 30701 |
| 2 | .2201 | 3-7/8 | 30702 |
| 3 | .2130 | 3-3/4 | 30703 |
| 4 | .2090 | 3-3/4 | 30704 |
| 5 | .2055 | 3-3/4 | 30705 |
| 6 | .2040 | 3-3/4 | 30706 |
| 7 | .2010 | 3-5/8 | 30707 |
| 8 | .1990 | 3-5/8 | 30708 |
| 9 | .1960 | 3-5/8 | 30709 |
| 10 | .1935 | 3-5/8 | 30710 |
| 11 | .1910 | 3-1/2 | 30711 |
| 12 | .1890 | 3-1/2 | 30712 |
| 13 | .1840 | 3-1/2 | 30713 |
| 14 | .1820 | 3-3/8 | 30714 |
| 15 | .1800 | 3-3/8 | 30715 |
| 16 | .1770 | 3-3/8 | 30716 |
| 17 | .1730 | 3-3/8 | 30717 |
| 18 | .1695 | 3-1/4 | 30718 |
| 19 | .1660 | 3-1/4 | 30719 |
| 20 | .1610 | 3-1/4 | 30720 |
| 21 | .1590 | 3-1/4 | 30721 |
| 22 | .1570 | 3-1/8 | 30722 |
| 23 | .1540 | 3-1/8 | 30723 |
| 24 | .1520 | 3-1/8 | 30724 |
| 25 | .1495 | 3 | 30725 |
| 26 | .1470 | 3 | 30726 |
| 27 | .1440 | 3 | 30727 |
| 28 | .1405 | 2-7/8 | 30728 |
| 29 | .1360 | 2-7/8 | 30729 |
| 30 | .1285 | 2-3/4 | 30730 |

| Size | Dec. Equiv | Overall Length | Product Number Bulk |
|------|------------|----------------|---------------------|
| 31 | .1200 | 2-3/4 | 30731 |
| 32 | .1160 | 2-3/4 | 30732 |
| 33 | .1130 | 2-5/8 | 30733 |
| 34 | .1110 | 2-5/8 | 30734 |
| 35 | .1100 | 2-5/8 | 30735 |
| 36 | .1065 | 2-1/2 | 30736 |
| 37 | .1040 | 2-1/2 | 30737 |
| 38 | .1015 | 2-1/2 | 30738 |
| 39 | .0995 | 2-3/8 | 30739 |
| 40 | .0980 | 2-3/8 | 30740 |
| 41 | .0960 | 2-3/8 | 30741 |
| 42 | .0935 | 2-1/4 | 30742 |
| 43 | .0890 | 2-1/4 | 30743 |
| 44 | .0860 | 2-1/8 | 30744 |
| 45 | .0820 | 2-1/8 | 30745 |
| 46 | .0810 | 2-1/8 | 30746 |
| 47 | .0785 | 2 | 30747 |
| 48 | .0760 | 2 | 30748 |
| 49 | .0730 | 2 | 30749 |
| 50 | .0700 | 2 | 30750 |
| 51 | .0670 | 2 | 30751 |
| 52 | .0635 | 1-7/8 | 30752 |
| 53 | .0595 | 1-7/8 | 30753 |
| 54 | .0550 | 1-7/8 | 30754 |
| 55 | .0520 | 1-7/8 | 30755 |
| 56 | .0465 | 1-3/4 | 30756 |
| 57 | .0430 | 1-3/4 | 30757 |
| 58 | .0420 | 1-5/8 | 30758 |
| 59 | .0410 | 1-5/8 | 30759 |
| 60 | .0400 | 1-5/8 | 30760 |

Technical Information (Applies to drills on pages 1-17)

Bright

Bright finish drills feature a highly polished flute for fast chip removal. Also available in left hand style, 310L series.

Heavy Duty Black

Heavy construction enables these drills to give greater service in harder materials such as forgings, stainless steels, and high tensile alloys. 135° split points ensure greater ease of penetration, no "walking," and minimum work hardening of materials.

Super Duty Bronze

Special premium hi-molybdenum M-7 steel plus heavy duty construction gives superior service in harder materials such as forgings, stainless steels, and high tensile alloys. 135° split points ensure greater ease of penetration, no "walking," and minimum working hardening of materials. These drills feature a bronze surface treatment for maximum lubricity.

Features

- 135° Split Point
- No. 52 & Smaller 118° Split Point
- Straight Shank
- Surface Treated
- High Speed Steel
- 5 per pack

Super Duty Black and Gold



| Size | Dec. Equiv | Overall Length | Product Number Bulk |
|------|------------|----------------|---------------------|
| 1 | .2280" | 3-7/8" | 36301 |
| 2 | .2201 | 3-7/8 | 36302 |
| 3 | .2130 | 3-3/4 | 36303 |
| 4 | .2090 | 3-3/4 | 36304 |
| 5 | .2055 | 3-3/4 | 36305 |
| 6 | .2040 | 3-3/4 | 36306 |
| 7 | .2010 | 3-5/8 | 36307 |
| 8 | .1990 | 3-5/8 | 36308 |
| 9 | .1960 | 3-5/8 | 36309 |
| 10 | .1935 | 3-5/8 | 36310 |
| 11 | .1910 | 3-1/2 | 36311 |
| 12 | .1890 | 3-1/2 | 36312 |
| 13 | .1840 | 3-1/2 | 36313 |
| 14 | .1820 | 3-3/8 | 36314 |
| 15 | .1800 | 3-3/8 | 36315 |
| 16 | .1770 | 3-3/8 | 36316 |
| 17 | .1730 | 3-3/8 | 36317 |
| 18 | .1695 | 3-1/4 | 36318 |
| 19 | .1660 | 3-1/4 | 36319 |
| 20 | .1610 | 3-1/4 | 36320 |
| 21 | .1590 | 3-1/4 | 36321 |
| 22 | .1570 | 3-1/8 | 36322 |
| 23 | .1540 | 3-1/8 | 36323 |
| 24 | .1520 | 3-1/8 | 36324 |
| 25 | .1495 | 3 | 36325 |
| 26 | .1470 | 3 | 36326 |
| 27 | .1440 | 3 | 36327 |
| 28 | .1405 | 2-7/8 | 36328 |
| 29 | .1360 | 2-7/8 | 36329 |
| 30 | .1285 | 2-3/4 | 36330 |

| Size | Dec. Equiv | Overall Length | Product Number Bulk |
|------|------------|----------------|---------------------|
| 31 | .1200 | 2-3/4 | 36331 |
| 32 | .1160 | 2-3/4 | 36332 |
| 33 | .1130 | 2-5/8 | 36333 |
| 34 | .1110 | 2-5/8 | 36334 |
| 35 | .1100 | 2-5/8 | 36335 |
| 36 | .1065 | 2-1/2 | 36336 |
| 37 | .1040 | 2-1/2 | 36337 |
| 38 | .1015 | 2-1/2 | 36338 |
| 39 | .0995 | 2-3/8 | 36339 |
| 40 | .0980 | 2-3/8 | 36340 |
| 41 | .0960 | 2-3/8 | 36341 |
| 42 | .0935 | 2-1/4 | 36342 |
| 43 | .0890 | 2-1/4 | 36343 |
| 44 | .0860 | 2-1/8 | 36344 |
| 45 | .0820 | 2-1/8 | 36345 |
| 46 | .0810 | 2-1/8 | 36346 |
| 47 | .0785 | 2 | 36347 |
| 48 | .0760 | 2 | 36348 |
| 49 | .0730 | 2 | 36349 |
| 50 | .0700 | 2 | 36350 |
| 51 | .0670 | 2 | 36351 |
| 52 | .0635 | 1-7/8 | 36352 |
| 53 | .0595 | 1-7/8 | 36353 |
| 54 | .0550 | 1-7/8 | 36354 |
| 55 | .0520 | 1-7/8 | 36355 |
| 56 | .0465 | 1-3/4 | 36356 |
| 57 | .0430 | 1-3/4 | 36357 |
| 58 | .0420 | 1-5/8 | 36358 |
| 59 | .0410 | 1-5/8 | 36359 |
| 60 | .0400 | 1-5/8 | 36360 |

Technical Information (Applies to drills on pages 1-17)

Black

Black finish drills have received a surface treatment which can reduce chip welding and improve cutting life.

Titanium

A super hard titanium nitride coating offers some important advantages: (1) increased tool life up to 600% over top grade HSS drills, (2) lowered friction for smoother, faster drilling with less pressure; and (3) better quality parts through reduced adhesion, welding and galling of chips to cutting edges.

Cobalt

Special heat resistant cobalt high speed steel plus heavy duty construction makes these drills an excellent choice for drilling holes in hard, tough materials such as stainless steels, manganese, etc. These drills have a gold color surface treatment for identification. 135° split points ensure greater ease of penetration, no "walking," and minimum work hardening of materials.



Jobbers Length Drills

Wire Gage Sizes · High Performance

Features

- 135° Split Point
- Heat Resistant Cobalt
- Straight Shank
- Surface Treated
- High Speed Steel
- 5 per pack

Cobalt



| Size | Dec. Equiv | Overall Length | Product Number Bulk |
|------|------------|----------------|---------------------|
| 1 | .2280" | 3-7/8" | 41201 |
| 2 | .2201 | 3-7/8" | 41202 |
| 3 | .2130 | 3-3/4" | 41203 |
| 4 | .2090 | 3-3/4" | 41204 |
| 5 | .2055 | 3-3/4" | 41205 |
| 6 | .2040 | 3-3/4" | 41206 |
| 7 | .2010 | 3-5/8" | 41207 |
| 8 | .1990 | 3-5/8" | 41208 |
| 9 | .1960 | 3-5/8" | 41209 |
| 10 | .1935 | 3-5/8" | 41210 |
| 11 | .1910 | 3-1/2" | 41211 |
| 12 | .1890 | 3-1/2" | 41212 |
| 13 | .1840 | 3-1/2" | 41213 |
| 14 | .1820 | 3-3/8" | 41214 |
| 15 | .1800 | 3-3/8" | 41215 |
| 16 | .1770 | 3-3/8" | 41216 |
| 17 | .1730 | 3-3/8" | 41217 |
| 18 | .1695 | 3-1/4" | 41218 |
| 19 | .1660 | 3-1/4" | 41219 |
| 20 | .1610 | 3-1/4" | 41220 |
| 21 | .1590 | 3-1/4" | 41221 |
| 22 | .1570 | 3-1/8" | 41222 |
| 23 | .1540 | 3-1/8" | 41223 |
| 24 | .1520 | 3-1/8" | 41224 |
| 25 | .1495 | 3 | 41225 |
| 26 | .1470 | 3 | 41226 |
| 27 | .1440 | 3 | 41227 |
| 28 | .1405 | 2-7/8" | 41228 |
| 29 | .1360 | 2-7/8" | 41229 |
| 30 | .1285 | 2-3/4" | 41230 |

| Size | Dec. Equiv | Overall Length | Product Number Bulk |
|------|------------|----------------|---------------------|
| 31 | .1200 | 2-3/4" | 41231 |
| 32 | .1160 | 2-3/4" | 41232 |
| 33 | .1130 | 2-5/8" | 41233 |
| 34 | .1110 | 2-5/8" | 41234 |
| 35 | .1100 | 2-5/8" | 41235 |
| 36 | .1065 | 2-1/2" | 41236 |
| 37 | .1040 | 2-1/2" | 41237 |
| 38 | .1015 | 2-1/2" | 41238 |
| 39 | .0995 | 2-3/8" | 41239 |
| 40 | .0980 | 2-3/8" | 41240 |
| 41 | .0960 | 2-3/8" | 41241 |
| 42 | .0935 | 2-1/4" | 41242 |
| 43 | .0890 | 2-1/4" | 41243 |
| 44 | .0860 | 2-1/8" | 41244 |
| 45 | .0820 | 2-1/8" | 41245 |
| 46 | .0810 | 2-1/8" | 41246 |
| 47 | .0785 | 2 | 41247 |
| 48 | .0760 | 2 | 41248 |
| 49 | .0730 | 2 | 41249 |
| 50 | .0700 | 2 | 41250 |
| 51 | .0670 | 2 | 41251 |
| 52 | .0635 | 1-7/8" | 41252 |
| 53 | .0595 | 1-7/8" | 41253 |
| 54 | .0550 | 1-7/8" | 41254 |
| 55 | .0520 | 1-7/8" | 41255 |
| 56 | .0465 | 1-3/4" | 41256 |
| 57 | .0430 | 1-3/4" | 41257 |
| 58 | .0420 | 1-5/8" | 41258 |
| 59 | .0410 | 1-5/8" | 41259 |
| 60 | .0400 | 1-5/8" | 41260 |



*Drill Sets
available
on page 31*

Features

- 118° Split Point
- Straight Shank
- High Speed Steel
- Highly Polished Flute
- Great for everyday use
- 5 per pack

Bright



| Size | Dec. Equiv | Overall Length | Product Number | |
|------|------------|----------------|----------------|--------|
| | | | Bulk | Carded |
| 1 | .2280" | 3-7/8" | 41001 | 41101 |
| 2 | .2201 | 3-7/8 | 41002 | 41102 |
| 3 | .2130 | 3-3/4 | 41003 | 41103 |
| 4 | .2090 | 3-3/4 | 41004 | 41104 |
| 5 | .2055 | 3-3/4 | 41005 | 41105 |
| 6 | .2040 | 3-3/4 | 41006 | 41106 |
| 7 | .2010 | 3-5/8 | 41007 | 41107 |
| 8 | .1990 | 3-5/8 | 41008 | 41108 |
| 9 | .1960 | 3-5/8 | 41009 | 41109 |
| 10 | .1935 | 3-5/8 | 41010 | 41110 |
| 11 | .1910 | 3-1/2 | 41011 | 41111 |
| 12 | .1890 | 3-1/2 | 41012 | 41112 |
| 13 | .1840 | 3-1/2 | 41013 | 41113 |
| 14 | .1820 | 3-3/8 | 41014 | 41114 |
| 15 | .1800 | 3-3/8 | 41015 | 41115 |
| 16 | .1770 | 3-3/8 | 41016 | 41116 |
| 17 | .1730 | 3-3/8 | 41017 | 41117 |
| 18 | .1695 | 3-1/4 | 41018 | 41118 |
| 19 | .1660 | 3-1/4 | 41019 | 41119 |
| 20 | .1610 | 3-1/4 | 41020 | 41120 |
| 21 | .1590 | 3-1/4 | 41021 | 41121 |
| 22 | .1570 | 3-1/8 | 41022 | 41122 |
| 23 | .1540 | 3-1/8 | 41023 | 41123 |
| 24 | .1520 | 3-1/8 | 41024 | 41124 |
| 25 | .1495 | 3 | 41025 | 41125 |
| 26 | .1470 | 3 | 41026 | 41126 |
| 27 | .1440 | 3 | 41027 | 41127 |
| 28 | .1405 | 2-7/8 | 41028 | 41128 |
| 29 | .1360 | 2-7/8 | 41029 | 41129 |
| 30 | .1285 | 2-3/4 | 41030 | 41130 |
| 31 | .1200 | 2-3/4 | 41031 | 41131 |
| 32 | .1160 | 2-3/4 | 41032 | 41132 |
| 33 | .1130 | 2-5/8 | 41033 | 41133 |
| 34 | .1110 | 2-5/8 | 41034 | 41134 |
| 35 | .1100 | 2-5/8 | 41035 | 41135 |
| 36 | .1065 | 2-1/2 | 41036 | 41136 |
| 37 | .1040 | 2-1/2 | 41037 | 41137 |
| 38 | .1015 | 2-1/2 | 41038 | 41138 |
| 39 | .0995 | 2-3/8 | 41039 | 41139 |
| 40 | .0980 | 2-3/8 | 41040 | 41140 |

| Size | Dec. Equiv | Overall Length | Product Number | |
|------|------------|----------------|----------------|--------|
| | | | Bulk | Carded |
| 41 | .0960 | 2-3/8 | 41041 | 41141 |
| 42 | .0935 | 2-1/4 | 41042 | 41142 |
| 43 | .0890 | 2-1/4 | 41043 | 41143 |
| 44 | .0860 | 2-1/8 | 41044 | 41144 |
| 45 | .0820 | 2-1/8 | 41045 | 41145 |
| 46 | .0810 | 2-1/8 | 41046 | 41146 |
| 47 | .0785 | 2 | 41047 | 41147 |
| 48 | .0760 | 2 | 41048 | 41148 |
| 49 | .0730 | 2 | 41049 | 41149 |
| 50 | .0700 | 2 | 41050 | 41150 |
| 51 | .0670 | 2 | 41051 | 41151 |
| 52 | .0635 | 1-7/8 | 41052 | 41152 |
| 53 | .0595 | 1-7/8 | 41053 | 41153 |
| 54 | .0550 | 1-7/8 | 41054 | 41154 |
| 55 | .0520 | 1-7/8 | 41055 | 41155 |
| 56 | .0465 | 1-3/4 | 41056 | 41156 |
| 57 | .0430 | 1-3/4 | 41057 | 41157 |
| 58 | .0420 | 1-5/8 | 41058 | 41158 |
| 59 | .0410 | 1-5/8 | 41059 | 41159 |
| 60 | .0400 | 1-5/8 | 41060 | 41160 |
| 61 | .0390 | 1-5/8 | 41061 | 41161 |
| 62 | .0380 | 1-1/2 | 41062 | 41162 |
| 63 | .0370 | 1-1/2 | 41063 | 41163 |
| 64 | .0360 | 1-1/2 | 41064 | 41164 |
| 65 | .0350 | 1-1/2 | 41065 | 41165 |
| 66 | .0330 | 1-3/8 | 41066 | 41166 |
| 67 | .0320 | 1-3/8 | 41067 | 41167 |
| 68 | .0310 | 1-3/8 | 41068 | 41168 |
| 69 | .0292 | 1-3/8 | 41069 | 41169 |
| 70 | .0280 | 1-1/4 | 41070 | 41170 |
| 71 | .0260 | 1-1/4 | 41071 | 41171 |
| 72 | .0250 | 1-1/4 | 41072 | 41172 |
| 73 | .0240 | 1 | 41073 | 41173 |
| 74 | .0225 | 1 | 41074 | 41174 |
| 75 | .0210 | 1 | 41075 | 41175 |
| 76 | .0200 | 7/8 | 41076 | 41176 |
| 77 | .0180 | 7/8 | 41077 | 41177 |
| 78 | .0160 | 7/8 | 41078 | 41178 |
| 79 | .0145 | 3/4 | 41079 | 41179 |
| 80 | .0135 | 3/4 | 41080 | 41180 |



Jobbers Length Drills

Wire Gage Sizes

Features

- 118° Split Point
- Surface Treated
- Straight Shank
- Great for everyday use
- High Speed Steel
- 5 per pack

Black



| Size | Dec. Equiv | Overall Length | Product Number Bulk |
|------|------------|----------------|---------------------|
| 1 | .2280" | 3-7/8" | 40901 |
| 2 | .2201 | 3-7/8 | 40902 |
| 3 | .2130 | 3-3/4 | 40903 |
| 4 | .2090 | 3-3/4 | 40904 |
| 5 | .2055 | 3-3/4 | 40905 |
| 6 | .2040 | 3-3/4 | 40906 |
| 7 | .2010 | 3-5/8 | 40907 |
| 8 | .1990 | 3-5/8 | 40908 |
| 9 | .1960 | 3-5/8 | 40909 |
| 10 | .1935 | 3-5/8 | 40910 |
| 11 | .1910 | 3-1/2 | 40911 |
| 12 | .1890 | 3-1/2 | 40912 |
| 13 | .1840 | 3-1/2 | 40913 |
| 14 | .1820 | 3-3/8 | 40914 |
| 15 | .1800 | 3-3/8 | 40915 |
| 16 | .1770 | 3-3/8 | 40916 |
| 17 | .1730 | 3-3/8 | 40917 |
| 18 | .1695 | 3-1/4 | 40918 |
| 19 | .1660 | 3-1/4 | 40919 |
| 20 | .1610 | 3-1/4 | 40920 |
| 21 | .1590 | 3-1/4 | 40921 |
| 22 | .1570 | 3-1/8 | 40922 |
| 23 | .1540 | 3-1/8 | 40923 |
| 24 | .1520 | 3-1/8 | 40924 |
| 25 | .1495 | 3 | 40925 |
| 26 | .1470 | 3 | 40926 |
| 27 | .1440 | 3 | 40927 |
| 28 | .1405 | 2-7/8 | 40928 |
| 29 | .1360 | 2-7/8 | 40929 |
| 30 | .1285 | 2-3/4 | 40930 |

| Size | Dec. Equiv | Overall Length | Product Number Bulk |
|------|------------|----------------|---------------------|
| 31 | .1200 | 2-3/4 | 40931 |
| 32 | .1160 | 2-3/4 | 40932 |
| 33 | .1130 | 2-5/8 | 40933 |
| 34 | .1110 | 2-5/8 | 40934 |
| 35 | .1100 | 2-5/8 | 40935 |
| 36 | .1065 | 2-1/2 | 40936 |
| 37 | .1040 | 2-1/2 | 40937 |
| 38 | .1015 | 2-1/2 | 40938 |
| 39 | .0995 | 2-3/8 | 40939 |
| 40 | .0980 | 2-3/8 | 40940 |
| 41 | .0960 | 2-3/8 | 40941 |
| 42 | .0935 | 2-1/4 | 40942 |
| 43 | .0890 | 2-1/4 | 40943 |
| 44 | .0860 | 2-1/8 | 40944 |
| 45 | .0820 | 2-1/8 | 40945 |
| 46 | .0810 | 2-1/8 | 40946 |
| 47 | .0785 | 2 | 40947 |
| 48 | .0760 | 2 | 40948 |
| 49 | .0730 | 2 | 40949 |
| 50 | .0700 | 2 | 40950 |
| 51 | .0670 | 2 | 40951 |
| 52 | .0635 | 1-7/8 | 40952 |
| 53 | .0595 | 1-7/8 | 40953 |
| 54 | .0550 | 1-7/8 | 40954 |
| 55 | .0520 | 1-7/8 | 40955 |
| 56 | .0465 | 1-3/4 | 40956 |
| 57 | .0430 | 1-3/4 | 40957 |
| 58 | .0420 | 1-5/8 | 40958 |
| 59 | .0410 | 1-5/8 | 40959 |
| 60 | .0400 | 1-5/8 | 40960 |



*Drill Sets
available
on page 31*

Features

- 118° Split Point
- Straight Shank
- High Speed Steel
- Highly Polished Flute
- Great for everyday use
- 5 per pack

Black



| Size MM | Dec. Equiv | Overall Length MM | Inch | Prod. Num. Bulk | Size MM | Dec. Equiv | Overall Length MM | Inch | Prod. Num. Bulk | Size MM | Dec. Equiv | Overall Length MM | Inch | Prod. Num. Bulk |
|------------|---------------|----------------------|-------|--------------------|------------|---------------|----------------------|-------|--------------------|------------|---------------|----------------------|-------|--------------------|
| .35 | .0138" | 19 | 3/4 | 39035 | 3.10 | .1220 | 70 | 2-3/4 | 39310 | 7.20 | .2835 | 108 | 4-1/4 | 39720 |
| .40 | .0158 | 22 | 7/8 | 39040 | 3.20 | .1260 | 70 | 2-3/4 | 39320 | 7.25 | .2854 | 108 | 4-1/4 | 39725 |
| .45 | .0177 | 22 | 7/8 | 39045 | 3.25 | .1280 | 70 | 2-3/4 | 39325 | 7.30 | .2874 | 108 | 4-1/4 | 39730 |
| .50 | .0197 | 22 | 7/8 | 39050 | 3.30 | .1299 | 73 | 2-7/8 | 39330 | 7.40 | .2913 | 111 | 4-3/8 | 39740 |
| .55 | .0217 | 25 | 1 | 39055 | 3.40 | .1339 | 73 | 2-7/8 | 39340 | 7.50 | .2953 | 111 | 4-3/8 | 39750 |
| .50 | .0236 | 29 | 1-1/8 | 39060 | 3.50 | .1378 | 73 | 2-7/8 | 39350 | 7.60 | .2992 | 111 | 4-3/8 | 39760 |
| .65 | .0256 | 32 | 1-1/4 | 39065 | 3.60 | .1417 | 76 | 3 | 39360 | 7.70 | .3031 | 114 | 4-1/2 | 39770 |
| .70 | .0276 | 32 | 1-1/4 | 39070 | 3.70 | .1457 | 76 | 3 | 39370 | 7.75 | .3051 | 114 | 4-1/2 | 39775 |
| .75 | .0295 | 35 | 1-3/8 | 39075 | 3.75 | .1476 | 76 | 3 | 39375 | 7.80 | .3071 | 114 | 4-1/2 | 39780 |
| .80 | .0315 | 35 | 1-3/8 | 39080 | 3.80 | .1496 | 79 | 3 | 39380 | 7.90 | .3110 | 114 | 4-1/2 | 39790 |
| .85 | .0335 | 38 | 1-1/2 | 39085 | 3.90 | .1535 | 79 | 3-3/8 | 39390 | 8.00 | .3150 | 114 | 4-1/2 | 39800 |
| .90 | .0354 | 38 | 1-1/2 | 39090 | 4.00 | .1575 | 83 | 3-1/4 | 39400 | 8.10 | .3189 | 117 | 4-5/8 | 39810 |
| .95 | .0374 | 38 | 1-1/2 | 39095 | 4.10 | .1614 | 83 | 3-1/4 | 39410 | 8.20 | .3228 | 117 | 4-5/8 | 39820 |
| 1.00 | .0394 | 41 | 1-5/8 | 39100 | 4.20 | .1654 | 83 | 3-1/4 | 39420 | 8.25 | .3248 | 117 | 4-5/8 | 39825 |
| 1.05 | .0413 | 41 | 1-5/8 | 39105 | 4.25 | .1673 | 83 | 3-1/4 | 39425 | 8.30 | .3268 | 117 | 4-5/8 | 39830 |
| 1.10 | .0433 | 44 | 1-3/4 | 39110 | 4.30 | .1693 | 83 | 3-1/4 | 39430 | 8.40 | .3307 | 121 | 4-3/4 | 39840 |
| 1.15 | .0453 | 44 | 1-3/4 | 39115 | 4.40 | .1739 | 86 | 3-3/8 | 39440 | 8.50 | .3346 | 121 | 4-3/4 | 39850 |
| 1.20 | .0472 | 48 | 1-7/8 | 39120 | 4.50 | .1772 | 86 | 3-3/8 | 39450 | 8.60 | .3386 | 121 | 4-3/4 | 39860 |
| 1.25 | .0492 | 48 | 1-7/8 | 39125 | 4.60 | .1811 | 86 | 3-3/8 | 39460 | 8.70 | .3425 | 121 | 4-3/4 | 39870 |
| 1.30 | .0512 | 48 | 1-7/8 | 39130 | 4.70 | .1850 | 89 | 3-1/2 | 39470 | 8.75 | .3445 | 121 | 4-3/4 | 39875 |
| 1.35 | .0531 | 48 | 1-7/8 | 39135 | 4.75 | .1870 | 89 | 3-1/2 | 39475 | 8.80 | .3465 | 124 | 4-7/8 | 39880 |
| 1.40 | .0551 | 48 | 1-7/8 | 39140 | 4.80 | .1890 | 89 | 3-1/2 | 39480 | 8.90 | .3504 | 124 | 4-7/8 | 39890 |
| 1.45 | .0571 | 48 | 1-7/8 | 39145 | 4.90 | .1929 | 92 | 3-5/8 | 39490 | 9.00 | .3543 | 124 | 4-7/8 | 39900 |
| 1.50 | .0591 | 48 | 1-7/8 | 39150 | 5.00 | .1968 | 92 | 3-5/8 | 39500 | 9.10 | .3583 | 124 | 4-7/8 | 39910 |
| 1.55 | .0610 | 48 | 1-7/8 | 39155 | 5.10 | .2008 | 92 | 3-5/8 | 39510 | 9.20 | .3622 | 127 | 5 | 39920 |
| 1.60 | .0630 | 48 | 1-7/8 | 39160 | 5.20 | .2047 | 95 | 3-3/4 | 39520 | 9.25 | .3642 | 127 | 5 | 39925 |
| 1.65 | .0650 | 51 | 2 | 39165 | 5.25 | .2067 | 95 | 3-3/4 | 39525 | 9.30 | .3661 | 127 | 5 | 39930 |
| 1.70 | .0669 | 51 | 2 | 39170 | 5.30 | .2087 | 95 | 3-3/4 | 39530 | 9.40 | .3701 | 127 | 5 | 39940 |
| 1.75 | .0689 | 51 | 2 | 39175 | 5.40 | .2126 | 95 | 3-3/4 | 39540 | 9.50 | .3740 | 127 | 5 | 39950 |
| 1.80 | .0709 | 51 | 2 | 39180 | 5.50 | .2165 | 95 | 3-3/4 | 39550 | 9.60 | .3780 | 130 | 5-1/8 | 39960 |
| 1.85 | .0728 | 51 | 2 | 39185 | 5.60 | .2205 | 98 | 3-7/8 | 39560 | 9.70 | .3819 | 130 | 5-1/2 | 39970 |
| 1.90 | .0748 | 51 | 2 | 39190 | 5.70 | .2244 | 98 | 3-7/8 | 39570 | 9.75 | .3839 | 130 | 5-1/8 | 39975 |
| 1.95 | .0768 | 51 | 2 | 39195 | 5.75 | .2264 | 98 | 3-7/8 | 39575 | 9.80 | .3858 | 130 | 5-1/8 | 39980 |
| 2.00 | .0787 | 54 | 2-1/8 | 39200 | 5.80 | .2283 | 98 | 3-7/8 | 39580 | 9.90 | .3898 | 130 | 5-1/8 | 39990 |
| 2.05 | .0807 | 54 | 2-1/8 | 39205 | 5.90 | .2323 | 98 | 3-7/8 | 39590 | 10.00 | .3937 | 130 | 5-1/8 | 40000 |
| 2.10 | .0827 | 54 | 2-1/8 | 39210 | 6.00 | .2362 | 102 | 4 | 39600 | 10.50 | .4134 | 137 | 5-3/8 | 40005 |
| 2.15 | .0846 | 54 | 2-1/8 | 39215 | 6.10 | .2402 | 102 | 4 | 39610 | 11.00 | .4331 | 140 | 5-1/2 | 40010 |
| 2.20 | .0866 | 54 | 2-1/4 | 39220 | 6.20 | .2441 | 102 | 4 | 39620 | 11.50 | .4528 | 143 | 5-5/8 | 40015 |
| 2.25 | .0886 | 54 | 2-1/4 | 39225 | 6.25 | .2461 | 102 | 4 | 39625 | 12.00 | .4724 | 150 | 5-7/8 | 40020 |
| 2.30 | .0906 | 57 | 2-1/4 | 39230 | 6.30 | .2480 | 102 | 4 | 39630 | 12.50 | .4921 | 152 | 6 | 40025 |
| 2.35 | .0925 | 57 | 2-1/4 | 39235 | 6.40 | .2520 | 105 | 4-1/8 | 39640 | 13.00 | .5118 | 152 | 6 | 40030 |
| 2.40 | .0945 | 60 | 2-3/8 | 39240 | 6.50 | .2559 | 105 | 4-1/8 | 39650 | 13.50 | .5315 | 168 | 6-5/8 | 40035 |
| 2.45 | .0965 | 60 | 2-3/8 | 39245 | 6.60 | .2598 | 105 | 4-1/8 | 39660 | 14.00 | .5517 | 168 | 6-5/8 | 40040 |
| 2.50 | .0984 | 60 | 2-3/8 | 39250 | 6.70 | .2638 | 105 | 4-1/8 | 39670 | 14.50 | .5709 | 168 | 6-5/8 | 40045 |
| 2.60 | .1024 | 64 | 2-1/2 | 39260 | 6.75 | .2657 | 105 | 4-1/8 | 39675 | 15.00 | .5906 | 181 | 7-1/8 | 40050 |
| 2.70 | .1063 | 64 | 2-1/2 | 39270 | 6.80 | .2677 | 105 | 4-1/8 | 39680 | 15.50 | .6102 | 181 | 7-1/8 | 40055 |
| 2.75 | .1083 | 64 | 2-1/2 | 39275 | 6.90 | .2717 | 105 | 4-1/8 | 39690 | 16.00 | .6299 | 181 | 7-1/8 | 40060 |
| 2.80 | .1102 | 67 | 2-5/8 | 39280 | 7.00 | .2756 | 105 | 4-1/8 | 39700 | 16.50 | .6496 | 181 | 7-1/8 | 40065 |
| 2.90 | .1142 | 70 | 2-3/4 | 39290 | 7.10 | .2795 | 108 | 4-1/4 | 39710 | 17.00 | .6693 | 194 | 7-5/8 | 40070 |
| 3.00 | .1181 | 70 | 2-3/4 | 39300 | | | | | | | | | | |



Jobbers Length Drills

Letter Sizes · High Performance

Features

- 135° Split Point
- Surface Treated
- Straight Shank
- Heavy Duty Construction
- High Speed Steel
- 5 per pack

Heavy Duty Black



| Size | Dec. Equiv | Overall Length | Product Number Bulk |
|------|------------|----------------|---------------------|
| A | .234" | 3-7/8" | 30801 |
| B | .238 | 4 | 30802 |
| C | .242 | 4 | 30803 |
| D | .246 | 4 | 30804 |
| E | .250 | 4 | 30805 |
| F | .257 | 4-1/8 | 30806 |
| G | .261 | 4-1/8 | 30807 |
| H | .266 | 4-1/8 | 30808 |
| I | .272 | 4-1/8 | 30809 |
| J | .277 | 4-1/8 | 30810 |
| K | .281 | 4-1/4 | 30811 |
| L | .290 | 4-1/4 | 30812 |
| M | .295 | 4-3/8 | 30813 |

| Size | Dec. Equiv | Overall Length | Product Number Bulk |
|------|------------|----------------|---------------------|
| N | .302" | 4-3/8" | 30814 |
| O | .316 | 4-1/2 | 30815 |
| P | .323 | 4-5/8 | 30816 |
| Q | .332 | 4-3/4 | 30817 |
| R | .339 | 4-3/4 | 30818 |
| S | .348 | 4-7/8 | 30819 |
| T | .358 | 4-7/8 | 30820 |
| U | .368 | 5 | 30821 |
| V | .377 | 5 | 30822 |
| W | .386 | 5-1/8 | 30823 |
| X | .397 | 5-1/8 | 30824 |
| Y | .404 | 5-1/4 | 30825 |
| Z | .413 | 5-1/4 | 30826 |

Jobbers Length Drills

Letter Sizes · High Performance

Features

- 135° Split Point
- Surface Treated
- Straight Shank
- Heavy Duty Construction
- High Speed Steel
- 5 per pack

Cobalt



| Size | Dec. Equiv | Overall Length | Product Number Bulk |
|------|------------|----------------|---------------------|
| A | .234" | 3-7/8" | 31541 |
| B | .238 | 4 | 31542 |
| C | .242 | 4 | 31543 |
| D | .246 | 4 | 31544 |
| E | .250 | 4 | 31545 |
| F | .257 | 4-1/8 | 31546 |
| G | .261 | 4-1/8 | 31547 |
| H | .266 | 4-1/8 | 31548 |
| I | .272 | 4-1/8 | 31549 |
| J | .277 | 4-1/8 | 31550 |
| K | .281 | 4-1/4 | 31551 |
| L | .290 | 4-1/4 | 31552 |
| M | .295 | 4-3/8 | 31553 |

| Size | Dec. Equiv | Overall Length | Product Number Bulk |
|------|------------|----------------|---------------------|
| N | .302" | 4-3/8" | 31554 |
| O | .316 | 4-1/2 | 31555 |
| P | .323 | 4-5/8 | 31556 |
| Q | .332 | 4-3/4 | 31557 |
| R | .339 | 4-3/4 | 31558 |
| S | .348 | 4-7/8 | 31559 |
| T | .358 | 4-7/8 | 31560 |
| U | .368 | 5 | 31561 |
| V | .377 | 5 | 31562 |
| W | .386 | 5-1/8 | 31563 |
| X | .397 | 5-1/8 | 31564 |
| Y | .404 | 5-1/4 | 31565 |
| Z | .413 | 5-1/4/8 | 31566 |

Features

- 118° Split Point
- Straight Shank
- High Speed Steel
- Highly Polished Flute
- Great for everyday use
- 5 per pack

Bright



| Size | Dec. Equiv | Overall Length | Product Number Bulk | Carded |
|------|------------|----------------|---------------------|--------|
| A | .234" | 3-7/8" | 31501 | 31571 |
| B | .238 | 4 | 31502 | 31572 |
| C | .242 | 4 | 31503 | 31573 |
| D | .246 | 4 | 31504 | 31574 |
| E | .250 | 4 | 31505 | 31575 |
| F | .257 | 4-1/8 | 31506 | 31576 |
| G | .261 | 4-1/8 | 31507 | 31577 |
| H | .266 | 4-1/8 | 31508 | 31578 |
| I | .272 | 4-1/8 | 31509 | 31579 |
| J | .277 | 4-1/8 | 31510 | 31580 |
| K | .281 | 4-1/4 | 31511 | 31581 |
| L | .290 | 4-1/4 | 31512 | 31582 |
| M | .295 | 4-3/8 | 31513 | 31583 |

| Size | Dec. Equiv | Overall Length | Product Number Bulk | Carded |
|------|------------|----------------|---------------------|--------|
| N | .302" | 4-3/8" | 31514 | 31584 |
| O | .316 | 4-1/2 | 31515 | 31585 |
| P | .323 | 4-5/8 | 31516 | 31586 |
| Q | .332 | 4-3/4 | 31517 | 31587 |
| R | .339 | 4-3/4 | 31518 | 31588 |
| S | .348 | 4-7/8 | 31519 | 31589 |
| T | .358 | 4-7/8 | 31520 | 31590 |
| U | .368 | 5 | 31521 | 31591 |
| V | .377 | 5 | 31522 | 31592 |
| W | .386 | 5-1/8 | 31523 | 31593 |
| X | .397 | 5-1/8 | 31524 | 31594 |
| Y | .404 | 5-1/4 | 31525 | 31595 |
| Z | .413 | 5-1/4 | 31526 | 31596 |

Features

- 118° Split Point
- Straight Shank
- High Speed Steel
- Surface Treated
- Great for everyday use
- 5 per pack

Black



| Size | Dec. Equiv | Overall Length | Product Number Bulk |
|------|------------|----------------|---------------------|
| A | .234" | 3-7/8" | 31401 |
| B | .238 | 4 | 31402 |
| C | .242 | 4 | 31403 |
| D | .246 | 4 | 31404 |
| E | .250 | 4 | 31405 |
| F | .257 | 4-1/8 | 31406 |
| G | .261 | 4-1/8 | 31407 |
| H | .266 | 4-1/8 | 31408 |
| I | .272 | 4-1/8 | 31409 |
| J | .277 | 4-1/8 | 31410 |
| K | .281 | 4-1/4 | 31411 |
| L | .290 | 4-1/4 | 31412 |
| M | .295 | 4-3/8 | 31413 |

| Size | Dec. Equiv | Overall Length | Product Number Bulk |
|------|------------|----------------|---------------------|
| N | .302" | 4-3/8" | 31414 |
| O | .316 | 4-1/2 | 31415 |
| P | .323 | 4-5/8 | 31416 |
| Q | .332 | 4-3/4 | 31417 |
| R | .339 | 4-3/4 | 31418 |
| S | .348 | 4-7/8 | 31419 |
| T | .358 | 4-7/8 | 31420 |
| U | .368 | 5 | 31421 |
| V | .377 | 5 | 31422 |
| W | .386 | 5-1/8 | 31423 |
| X | .397 | 5-1/8 | 31424 |
| Y | .404 | 5-1/4 | 31425 |
| Z | .413 | 5-1/4 | 31426 |

3/8 Reduced Shank Drills

Fractional Sizes · High Performance

Features

- 135° Split Point
- Surface Treated
- Reduced Shank
- Fits electric drills with 3/8 Chuck
- High Speed Steel
- 5 per pack

Heavy Duty Black



| Size | Overall Length | Product Number | |
|--------|----------------|----------------|--------|
| | | Bulk | Carded |
| 25/64" | 5-1/8" | 40325 | 40225 |
| 13/32 | 5-1/4 | 40326 | 40226 |
| 27/64 | 5-3/8 | 40327 | 40227 |
| 7/16 | 5-1/2 | 40328 | 40228 |

| Size | Overall Length | Product Number | |
|-------|----------------|----------------|--------|
| | | Bulk | Carded |
| 29/64 | 5-5/8 | 40329 | 40229 |
| 15/32 | 5-3/4 | 40330 | 40230 |
| 31/64 | 5-7/8 | 40331 | 40231 |
| 1/2" | 6 | 40332 | 40232 |

3/8 Reduced Shank Drills

Fractional Sizes · High Performance

Features

- 135° Split Point
- Titanium Coating
- Reduced Shank
- Fits electric drills with 3/8 Chuck
- High Speed Steel
- 5 per pack

Titanium



| Size | Overall Length | Product Number | |
|--------|----------------|----------------|--------|
| | | Bulk | Carded |
| 25/64" | 5-1/8" | 36825 | 36925 |
| 13/32 | 5-1/4 | 36826 | 36926 |
| 27/64 | 5-3/8 | 36827 | 36927 |
| 7/16 | 5-1/2 | 36828 | 36928 |

| Size | Overall Length | Product Number | |
|-------|----------------|----------------|--------|
| | | Bulk | Carded |
| 29/64 | 5-5/8 | 36829 | 36929 |
| 15/32 | 5-3/4 | 36830 | 36930 |
| 31/64 | 5-7/8 | 36831 | 36931 |
| 1/2" | 6 | 36832 | 36932 |

3/8 Reduced Shank Drills

Fractional Sizes · High Performance

Features

- 135° Split Point
- Heat Resistant Cobalt
- Reduced Shank
- Fits electric drills with 3/8 Chuck
- High Speed Steel
- 5 per pack

Cobalt



| Size | Overall Length | Product Number | |
|--------|----------------|----------------|--------|
| | | Bulk | Carded |
| 25/64" | 5-1/8" | 37025 | 37125 |
| 13/32 | 5-1/4 | 37026 | 37126 |
| 27/64 | 5-3/8 | 37027 | 37127 |
| 7/16 | 5-1/2 | 37028 | 37128 |

| Size | Overall Length | Product Number | |
|-------|----------------|----------------|--------|
| | | Bulk | Carded |
| 29/64 | 5-5/8 | 37029 | 37129 |
| 15/32 | 5-3/4 | 37030 | 37130 |
| 31/64 | 5-7/8 | 37031 | 37131 |
| 1/2" | 6 | 37032 | 37132 |

3/8 Reduced Shank Drills

Fractional Sizes · High Performance

Features

- 135° Split Point
- Heavy Duty Construction
- Reduced Shank
- Fits electric drills with 3/8 Chuck
- High Speed Steel
- 5 per pack

Super Duty Black and Gold



| Size | Overall Length | Product Number Bulk |
|--------|----------------|---------------------|
| 25/64" | 5-1/8" | 40425 |
| 13/32 | 5-1/4 | 40426 |
| 27/64 | 5-3/8 | 40427 |
| 7/16 | 5-1/2 | 40428 |

| Size | Overall Length | Product Number Bulk |
|--------|----------------|---------------------|
| 29/64" | 5-5/8 | 40429 |
| 15/32 | 5-3/4 | 40430 |
| 31/64 | 5-7/8 | 40431 |
| 1/2 | 6 | 40432 |

3/8 Reduced Shank Drills

Fractional Sizes

Features

- 118° Split Point
- Great for everyday use
- Reduced Shank
- Fits electric drills with 3/8 Chuck
- High Speed Steel
- 5 per pack

Bright



| Size | Overall Length | Product Number Bulk | Carded |
|--------|----------------|---------------------|--------|
| 25/64" | 5-1/8" | 40725 | 40825 |
| 13/32 | 5-1/4 | 40726 | 40826 |
| 27/64 | 5-3/8 | 40727 | 40827 |
| 7/16 | 5-1/2 | 40728 | 40828 |

| Size | Overall Length | Product Number Bulk | Carded |
|--------|----------------|---------------------|--------|
| 29/64" | 5-5/8" | 40729 | 40829 |
| 15/32 | 5-3/4 | 40730 | 40830 |
| 31/64 | 5-7/8 | 40731 | 40831 |
| 1/2 | 6 | 40732 | 40832 |

3/8 Reduced Shank Drills

Fractional Sizes

Features

- 118° Split Point
- Great for everyday use
- Reduced Shank
- Fits electric drills with 3/8 Chuck
- High Speed Steel
- 5 per pack

Black



| Size | Overall Length | Product Number Bulk | Carded |
|--------|----------------|---------------------|--------|
| 25/64" | 5-1/8" | 40750 | 40870 |
| 13/32 | 5-1/4 | 40752 | 40872 |
| 27/64 | 5-3/8 | 40754 | 40874 |
| 7/16 | 5-1/2 | 40756 | 40876 |
| 29/64 | 5-5/8 | 40758 | 40878 |
| 15/32 | 5-3/4 | 40760 | 40880 |
| 31/64 | 5-7/8 | 40762 | 40882 |
| 1/2 | 6 | 40764 | 40884 |

| Size | Overall Length | Product Number Bulk | Carded |
|--------|----------------|---------------------|--------|
| 17/32" | 6 | - | 40834 |
| 9/16 | 6 | - | 40836 |
| 19/32 | 6 | - | 40838 |
| 5/8 | 6 | - | 40840 |
| 21/32 | 6 | - | 40842 |
| 11/16 | 6 | - | 40844 |
| 3/4 | 6 | - | 40848 |

1/2 Reduced Shank Drills

Fractional Sizes · High Performance

Features

- 135° Split Point
- Heavy Duty Construction
- 6" Overall Length
- 3 Flats Shank
- High Speed Steel
- Individually Packed

Silver and Deming



| Size | Overall Length | Product Number 3 Flats Shank |
|-------|----------------|---------------------------------|
| 17/32 | 6" | 42534 |
| 9/16 | 6 | 42536 |
| 19/32 | 6 | 42538 |
| 5/8 | 6 | 42540 |
| 21/32 | 6 | 42542 |
| 11/16 | 6 | 42544 |
| 23/32 | 6 | 42546 |
| 3/4 | 6 | 42548 |
| 25/32 | 6 | 42550 |
| 13/16 | 6 | 42552 |
| 27/32 | 6 | 42554 |
| 7/8 | 6 | 42556 |
| 29/32 | 6 | 42558 |

| Size | Overall Length | Product Number 3 Flats Shank |
|--------|----------------|---------------------------------|
| 15/16 | 6" | 42560 |
| 31/32" | 6 | 42562 |
| 1 | 6 | 42564 |
| 1-1/16 | 6 | 42568 |
| 1-1/32 | 6 | 42570 |
| 1-1/8 | 6 | 42572 |
| 1-5/32 | 6 | 42574 |
| 1-3/16 | 6 | 42576 |
| 1-1/4 | 6 | 42580 |
| 1-5/16 | 6 | 42584 |
| 1-3/8 | 6 | 42588 |
| 1-7/16 | 6 | 42592 |
| 1-1/2 | 6 | 42596 |

1/2 Reduced Shank Drills

Fractional Sizes · High Performance

Features

- 135° Split Point
- Heat Resistant Cobalt
- 6" Overall Length
- 3 Flats or Round Shank
- High Speed Steel
- Individually Packed

Cobalt Silver and Deming



| Size | Overall Length | Product Number | |
|-------|----------------|----------------|-------------|
| | | 3 Flats Shank | Round Shank |
| 9/16 | 6" | 42736 | 42936 |
| 19/32 | 6 | 42738 | 42938 |
| 5/8 | 6 | 42740 | 42940 |
| 21/32 | 6 | 42742 | 42942 |
| 11/16 | 6 | 42744 | 42944 |
| 23/32 | 6 | 42746 | 42946 |
| 3/4 | 6 | 42748 | 42948 |

| Size | Overall Length | Product Number | |
|-------|----------------|----------------|-------------|
| | | 3 Flats Shank | Round Shank |
| 25/32 | 6" | 42750 | 42950 |
| 13/16 | 6 | 42752 | 42952 |
| 27/32 | 6 | 42754 | 42954 |
| 7/8 | 6 | 42756 | 42956 |
| 29/32 | 6 | 42758 | 42958 |
| 15/16 | 6 | 42760 | 42960 |
| 31/32 | 6 | 42762 | 42962 |
| 1 | 6 | 42764 | 42964 |

Features

- 118° Split Point
- 6" Overall Length
- High Speed Steel
- Surface Treated
- 3 Flats or Round Shank
- Individually Packed

Black Silver and Deming



| Size | Overall Length | Product Number | |
|--------|----------------|----------------|-------------|
| | | 3 Flats Shank | Round Shank |
| 33/64" | 6" | 41533 | 41733 |
| 17/32 | 6 | 41534 | 41734 |
| 35/64 | 6 | 41535 | 41735 |
| 9/16 | 6 | 41536 | 41736 |
| 37/64 | 6 | 41537 | 41737 |
| 19/32 | 6 | 41538 | 41738 |
| 39/64 | 6 | 41539 | 41739 |
| 5/8 | 6 | 41540 | 41740 |
| 41/64 | 6 | 41541 | 41741 |
| 21/32 | 6 | 41542 | 41742 |
| 43/64 | 6 | 41543 | 41743 |
| 11/16 | 6 | 41544 | 41744 |
| 45/64 | 6 | 41545 | 41745 |
| 23/32 | 6 | 41546 | 41746 |
| 47/64" | 6 | 41547 | 41747 |
| 3/4 | 6 | 41548 | 41748 |
| 49/64 | 6 | 41549 | 41749 |
| 25/32 | 6 | 41550 | 41750 |
| 51/64 | 6 | 41551 | 41751 |
| 13/16 | 6 | 41552 | 41752 |
| 53/64 | 6 | 41553 | 41753 |
| 27/32 | 6 | 41554 | 41754 |

| Size | Overall Length | Product Number | |
|--------|----------------|----------------|-------------|
| | | 3 Flats Shank | Round Shank |
| 55/64" | 6" | 41555 | 41755 |
| 7/8 | 6 | 41556 | 41756 |
| 57/64 | 6 | 41557 | 41757 |
| 29/32 | 6 | 41558 | 41758 |
| 59/64 | 6 | 41559 | 41759 |
| 15/16 | 6 | 41560 | 41760 |
| 61/64 | 6 | 41561 | 41761 |
| 31/32" | 6 | 41562 | 41762 |
| 63/64 | 6 | 41563 | 41763 |
| 1 | 6 | 41564 | 41764 |
| 1-1/64 | 6 | 41565 | 41765 |
| 1-1/32 | 6 | 41566 | 41766 |
| 1-1/16 | 6 | 41568 | 41768 |
| 1-1/32 | 6 | 41570 | 41770 |
| 1-1/8 | 6 | 41572 | 41772 |
| 1-5/32 | 6 | 41574 | 41774 |
| 1-3/16 | 6 | 41576 | 41776 |
| 1-1/4 | 6 | 41580 | 41780 |
| 1-5/16 | 6 | 41584 | 41784 |
| 1-3/8 | 6 | 41588 | 41788 |
| 1-7/16 | 6 | 41592 | 41792 |
| 1-1/2 | 6 | 41596 | 41796 |

Technical Information

Drill Size Chart

The following chart shows the approximate range of sizes that are covered by each category of drills on pages 1 through 17.

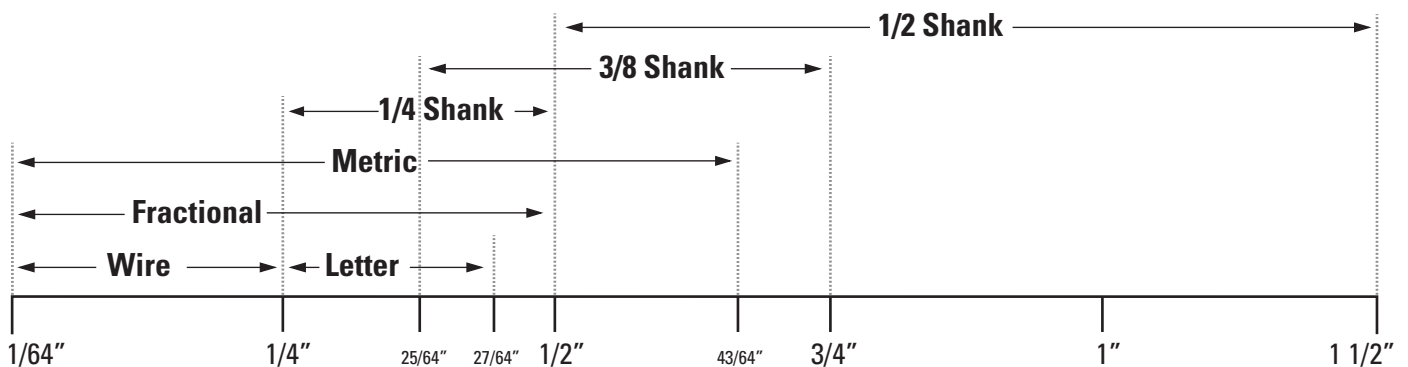

1/4 Reduced Shank Drills

Fractional Sizes

Features

- 118° Split Point
- Universal Length
- High Speed Steel
- Highly Polished Flute
- Fits all electric drills
- 5 per pack

Bright



| Size | Overall Length | Product Number | |
|--------|----------------|----------------|--------|
| | | Bulk | Carded |
| 17/64" | 3-11/16" | 40617 | 40517 |
| 9/32 | 3-3/4 | 40618 | 40518 |
| 19/64 | 4 | 40619 | 40519 |
| 5/16 | 4-1/16 | 40620 | 40520 |
| 21/64 | 4-1/4 | 40621 | 40521 |
| 11/32 | 4-1/4 | 40622 | 40522 |
| 23/64 | 4-1/2 | 40623 | 40523 |
| 3/8 | 4-1/2 | 40624 | 40524 |

| Size | Overall Length | Product Number | |
|--------|----------------|----------------|--------|
| | | Bulk | Carded |
| 25/64" | 4-11/16 | 40625 | 40525 |
| 13/32 | 4-11/16 | 40626 | 40526 |
| 27/64 | 4-7/8 | 40627 | 40527 |
| 7/16 | 4-7/8 | 40628 | 40528 |
| 29/64 | 5 | 40629 | 40529 |
| 15/32 | 5 | 40630 | 40530 |
| 31/64 | 5-1/8 | 40631 | 40531 |
| 1/2 | 5-1/4 | 40632 | 40532 |

1/4 Reduced Shank Drills

Fractional Sizes

Features

- 118° Split Point
- Universal Length
- High Speed Steel
- Surface Treated
- Fits all electric drills
- 5 per pack

Black



| Size | Overall Length | Product Number | |
|--------|----------------|----------------|--------|
| | | Bulk | Carded |
| 17/64" | 3-11/16" | 40634 | 40534 |
| 9/32 | 3-3/4 | 40636 | 40536 |
| 19/64 | 4 | 40638 | 40538 |
| 5/16 | 4-1/16 | 40640 | 40540 |
| 21/64 | 4-1/4 | 40642 | 40542 |
| 11/32 | 4-1/4 | 40644 | 40544 |
| 23/64 | 4-1/2 | 40646 | 40546 |
| 3/8 | 4-1/2 | 40648 | 40548 |

| Size | Overall Length | Product Number | |
|--------|----------------|----------------|--------|
| | | Bulk | Carded |
| 25/64" | 4-11/16 | 40650 | 40550 |
| 13/32 | 4-11/16 | 40652 | 40552 |
| 27/64 | 4-7/8 | 40654 | 40554 |
| 7/16 | 4-7/8 | 40656 | 40556 |
| 29/64 | 5 | 40668 | 40558 |
| 15/32 | 5 | 40660 | 40560 |
| 31/64 | 5-1/8 | 40662 | 40562 |
| 1/2 | 5-1/4 | 40664 | 40564 |



12" Long Drills Fractional Sizes

Features

- 118° Split Point
- Highly Polished Flute
- 12" Overall Length
- Great for hard to reach places
- High Speed Steel
- 5 per pack

Bright Finish



| Size | Flute Length | Product Number | |
|-------|--------------|----------------|------------|
| | | Straight Shank | 1/2" Shank |
| 1/8" | 9" | 42008 | - |
| 9/64 | 9 | 42009 | - |
| 5/32 | 9 | 42010 | - |
| 11/64 | 9 | 42011 | - |
| 3/16 | 9 | 42012 | - |
| 13/64 | 9 | 42013 | - |
| 7/32 | 9 | 42014 | - |
| 15/64 | 9 | 42015 | - |
| 1/4 | 9 | 42016 | - |
| 17/64 | 9 | 42017 | - |
| 9/32 | 9 | 42018 | - |
| 19/64 | 9 | 42019 | - |
| 5/16 | 9 | 42020 | - |
| 21/64 | 9 | 42021 | - |
| 11/32 | 9 | 42022 | - |
| 23/64 | 9 | 42023 | - |

| Size | Flute Length | Product Number | |
|-------|--------------|----------------|------------|
| | | Straight Shank | 1/2" Shank |
| 3/8" | 9" | 42024 | - |
| 25/64 | 9 | 42025 | - |
| 13/32 | 9 | 42026 | - |
| 27/64 | 9 | 42027 | - |
| 7/16 | 9 | 42028 | - |
| 29/64 | 9 | 42029 | - |
| 15/32 | 9 | 42030 | - |
| 31/64 | 9 | 42031 | - |
| 1/2 | 9 | 42032 | - |
| 17/32 | 9 | 42034 | 42134 |
| 9/16 | 9 | 42036 | 42136 |
| 19/32 | 9 | 42038 | 42138 |
| 5/8 | 9 | 42040 | 42140 |
| 11/16 | 9 | 42044 | 42144 |
| 3/4 | 9 | 42048 | 42148 |

18" Long Drills Fractional Sizes

Features

- 118° Split Point
- Highly Polished Flute
- 18" Overall Length
- Great for hard to reach places
- High Speed Steel
- 5 per pack

Bright Finish



| Size | Flute Length | Product Number | |
|-------|--------------|----------------|------------|
| | | Straight Shank | 1/2" Shank |
| 3/16" | 10" | 42212 | - |
| 7/32 | 10 | 42214 | - |
| 1/4 | 12 | 42216 | - |
| 9/32 | 12 | 42218 | - |
| 5/16 | 12 | 42220 | - |
| 11/32 | 12 | 42222 | - |
| 3/8 | 13-1/2 | 42224 | - |
| 13/32 | 13-1/2 | 42226 | - |
| 7/16 | 13-1/2 | 42228 | - |

| Size | Flute Length | Product Number | |
|--------|--------------|----------------|------------|
| | | Straight Shank | 1/2" Shank |
| 15/32" | 13-1/2 | 42230 | - |
| 1/2 | 13-1/2 | 42232 | - |
| 17/32 | 14 | 42234 | 42334 |
| 9/16 | 14 | 42236 | 42336 |
| 19/32 | 14 | 42238 | 42338 |
| 5/8 | 14 | 42240 | 42340 |
| 11/16 | 14 | 42244 | 42344 |
| 3/4 | 14 | 42248 | 42348 |

6" Aircraft Extension Drills

Fractional Sizes · High Performance

Features

- 135° Split Point
- Surface Treated
- 6" Overall Length
- Great for hard to reach places
- High Speed Steel
- 5 per pack

Black Finish



| Size | Flute Length | Product Number Bulk | Product Number Carded | Size | Flute Length | Product Number Bulk | Product Number Carded | Size | Flute Length | Product Number Bulk | Product Number Carded |
|-------|--------------|---------------------|-----------------------|--------|--------------|---------------------|-----------------------|-------|--------------|---------------------|-----------------------|
| 3/64" | 3/4" | 38803 | - | 9/64 | 1-3/4 | 38809 | - | 15/64 | 2-5/8 | 38815 | - |
| 1/16 | 7/8 | 38804 | 38904 | 5/32 | 2 | 38810 | 38910 | 1/4 | 2-3/4 | 38816 | 38916 |
| 5/64 | 1 | 38805 | - | 11/64 | 2-1/8 | 38811 | - | 5/16 | 3-3/16 | 38820 | 38920 |
| 3/32 | 1-1/4 | 38806 | 38906 | 3/16 | 2-5/16 | 38812 | 38912 | 3/8 | 3-5/8 | 38824 | 38924 |
| 7/64 | 1-1/2 | 38807 | - | 13/64" | 2-7/16" | 38813 | - | 7/16 | 4-1/16 | 38828 | 38928 |
| 1/8 | 1-5/8 | 38808 | 38908 | 7/32 | 2-1/2 | 38814 | 38914 | 1/2 | 4-1/2 | 38832 | 38932 |

6" Aircraft Extension Drills

Wire Gauge Sizes · High Performance

Features

- 135° Split Point
- Surface Treated
- 6" Overall Length
- Great for hard to reach places
- High Speed Steel
- 5 per pack

Black Finish



| Size | Flute Length | Product Number Bulk | Size | Flute Length | Product Number Bulk | Size | Flute Length | Product Number Bulk |
|------|--------------|---------------------|------|--------------|---------------------|------|--------------|---------------------|
| 1 | 2-5/8 | 41301 | 21 | 2-1/8 | 41321 | 41 | 1-3/8 | 41341 |
| 2 | 2-5/8 | 41302 | 22 | 2-1/8 | 41322 | 42 | 1-1/4 | 41342 |
| 3 | 2-1/2 | 41303 | 23 | 2 | 41323 | 43 | 1-1/4 | 41343 |
| 4 | 2-1/2 | 41304 | 24 | 2 | 41324 | 44 | 1-1/8 | 41344 |
| 5 | 2-1/2 | 41305 | 25 | 1-7/8 | 41325 | 45 | 1-1/8 | 41345 |
| 6 | 2-1/2 | 41306 | 26 | 1-7/8 | 41326 | 46 | 1-1/8 | 41346 |
| 7 | 2-7/16 | 41307 | 27 | 1-3/4 | 41327 | 47 | 1 | 41347 |
| 8 | 2-7/16 | 41308 | 28 | 1-3/4 | 41328 | 48 | 1 | 41348 |
| 9 | 2-7/16 | 41309 | 29 | 1-3/4 | 41329 | 49 | 1 | 41349 |
| 10 | 2-7/16 | 41310 | 30 | 1-5/8 | 41330 | 50 | 1 | 41350 |
| 11 | 2-5/16 | 41311 | 31 | 1-5/7 | 41331 | 51 | 1 | 41351 |
| 12 | 2-5/16 | 41312 | 32 | 1-5/8 | 41332 | 52 | 7/8 | 41352 |
| 13 | 2-5/16 | 41313 | 33 | 1-1/2 | 41333 | 53 | 7/8 | 41353 |
| 14 | 2-3/16 | 41314 | 34 | 1-1/2 | 41334 | 54 | 7/8 | 41354 |
| 15 | 2-3/16 | 41315 | 35 | 1-1/2 | 41335 | 55 | 7/8 | 41355 |
| 16 | 2-3/16 | 41316 | 36 | 1-7/16 | 41336 | 56 | 3/4 | 41356 |
| 17 | 2-3/16 | 41317 | 37 | 1-7/16 | 41337 | 57 | 3/4 | 41357 |
| 18 | 2-1/8 | 41318 | 38 | 1-7/16 | 41338 | 58 | 11/16 | 41358 |
| 19 | 2-1/8 | 41319 | 39 | 1-3/8 | 41339 | 59 | 11/16 | 41359 |
| 20 | 2-1/8 | 41320 | 40 | 1-3/8 | 41340 | 60 | 11/16 | 41360 |

12" Aircraft Extension Drills

Fractional Sizes · High Performance

Features

- 135° Split Point
- Surface Treated
- 12" Overall Length
- Great for hard to reach places
- High Speed Steel
- 5 per pack

Black Finish



| Size | Flute Length | Product Number Bulk | Carded | Size | Flute Length | Product Number Bulk | Carded | Size | Flute Length | Product Number Bulk | Carded |
|-------|--------------|---------------------|--------|--------|--------------|---------------------|--------|--------|--------------|---------------------|--------|
| 3/64" | 3/4" | 38403 | - | 13/64" | 2-7/16" | 38413 | - | 23/64" | 3-1/2" | 38423 | - |
| 1/16 | 7/8 | 38404 | 38604 | 7/32 | 2-1/2 | 38414 | 38614 | 3/8 | 3-5/8 | 38424 | 38624 |
| 5/64 | 1 | 38405 | - | 15/64 | 2-5/8 | 38415 | - | 25/64 | 3-3/4 | 38425 | - |
| 3/32 | 1-1/4 | 38406 | 38606 | 1/4 | 2-3/4 | 38416 | 38616 | 13/32 | 3-7/8 | 38426 | - |
| 7/64 | 1-1/2 | 38407 | - | 17/64 | 2-7/8 | 38417 | - | 27/64 | 3-15/16 | 38427 | - |
| 1/8 | 1-5/8 | 38408 | 38608 | 9/32 | 2-15/16 | 38418 | - | 7/16 | 4-1/16 | 38428 | 38628 |
| 9/64 | 1-3/4 | 38409 | - | 19/64 | 3-1/16 | 38419 | - | 29/64 | 4-3/16 | 38429 | - |
| 5/32 | 2 | 38410 | 38610 | 5/16 | 3-3/16 | 38420 | 38620 | 15/32 | 4-5/16 | 38430 | - |
| 11/64 | 2-1/8 | 38411 | - | 21/64 | 3-5/16 | 38421 | - | 31/64 | 4-3/8 | 38431 | - |
| 3/16 | 2-5/16 | 38412 | 38612 | 11/32 | 3-7/16 | 38422 | - | 1/2 | 4-1/2 | 38432 | 38632 |

12" Aircraft Extension Drills

Wire Gauge Sizes · High Performance

Features

- 135° Split Point
- Surface Treated
- 12" Overall Length
- Great for hard to reach places
- High Speed Steel
- 5 per pack

Black Finish



| Size | Flute Length | Product Number Bulk | Size | Flute Length | Product Number Bulk | Size | Flute Length | Product Number Bulk |
|------|--------------|---------------------|------|--------------|---------------------|------|--------------|---------------------|
| 1 | 2-5/8 | 41401 | 21 | 2-1/8 | 41421 | 41 | 1-3/8 | 41441 |
| 2 | 2-5/8 | 41402 | 22 | 2-1/8 | 41422 | 42 | 1-1/4 | 41442 |
| 3 | 2-1/2 | 41403 | 23 | 2 | 41423 | 43 | 1-1/4 | 41443 |
| 4 | 2-1/2 | 41404 | 24 | 2 | 41424 | 44 | 1-1/8 | 41444 |
| 5 | 2-1/2 | 41405 | 25 | 1-7/8 | 41425 | 45 | 1-1/8 | 41445 |
| 6 | 2-1/2 | 41406 | 26 | 1-7/8 | 41426 | 46 | 1-1/8 | 41446 |
| 7 | 2-7/16 | 41407 | 27 | 1-3/4 | 41427 | 47 | 1 | 41447 |
| 8 | 2-7/16 | 41408 | 28 | 1-3/4 | 41428 | 48 | 1 | 41448 |
| 9 | 2-7/16 | 41409 | 29 | 1-3/4 | 41429 | 49 | 1 | 41449 |
| 10 | 2-7/16 | 41410 | 30 | 1-5/8 | 41430 | 50 | 1 | 41450 |
| 11 | 2-5/16 | 41411 | 31 | 1-5/7 | 41431 | 51 | 1 | 41451 |
| 12 | 2-5/16 | 41412 | 32 | 1-5/8 | 41432 | 52 | 7/8 | 41452 |
| 13 | 2-5/16 | 41413 | 33 | 1-1/2 | 41433 | 53 | 7/8 | 41453 |
| 14 | 2-3/16 | 41414 | 34 | 1-1/2 | 41434 | 54 | 7/8 | 41454 |
| 15 | 2-3/16 | 41415 | 35 | 1-1/2 | 41435 | 55 | 7/8 | 41455 |
| 16 | 2-3/16 | 41416 | 36 | 1-7/16 | 41436 | 56 | 3/4 | 41456 |
| 17 | 2-3/16 | 41417 | 37 | 1-7/16 | 41437 | 57 | 3/4 | 41457 |
| 18 | 2-1/8 | 41418 | 38 | 1-7/16 | 41438 | 58 | 11/16 | 41458 |
| 19 | 2-1/8 | 41419 | 39 | 1-3/8 | 41439 | 59 | 11/16 | 41459 |
| 20 | 2-1/8 | 41420 | 40 | 1-3/8 | 41440 | 60 | 11/16 | 41460 |



Screw Machine (Stub Length) Drills

Fractional Sizes

Features

- 135° Split Point
- Straight Shank
- High Speed Steel
- Heavy Duty Construction
- 10 per pack 1/4" and smaller
- 5 per pack 17/64" and larger

Heavy Duty Black



| Size | Overall Length | Product Number Right | Product Number Left |
|-------|----------------|----------------------|---------------------|
| 1/16" | 1-5/8" | 31304 | 31304L |
| 5/64 | 1-11/16 | 31305 | 31305L |
| 3/32 | 1-3/4 | 31306 | 31306L |
| 7/64 | 1-13/16 | 31307 | 31307L |
| 1/8 | 1-7/8 | 31308 | 31308L |
| 9/64 | 1-15/16 | 31309 | 31309L |
| 5/32 | 2-1/16 | 31310 | 31310L |
| 11/64 | 2-1/8 | 31311 | 31311L |
| 3/16 | 2-3/16 | 31312 | 31312L |
| 13/64 | 2-1/4 | 31313 | 31313L |

| Size | Overall Length | Product Number Right | Product Number Left |
|-------|----------------|----------------------|---------------------|
| 7/32" | 2-3/8 | 31314 | 31314L |
| 15/64 | 2-7/16 | 31315 | 31315L |
| 1/4 | 2-1/2 | 31316 | 31316L |
| 17/64 | 2-5/8 | 31317 | 31317L |
| 9/32 | 2-11/16 | 31318 | 31318L |
| 19/64 | 2-3/4" | 31319 | 31319L |
| 5/16 | 2-13/16 | 31320 | 31320L |
| 21/64 | 2-15/16 | 31321 | 31321L |
| 11/32 | 3 | 31322 | 31322L |
| 23/64 | 3-1/16 | 31323 | 31323L |

| Size | Overall Length | Product Number Right | Product Number Left |
|-------|----------------|----------------------|---------------------|
| 3/8" | 3-1/8 | 31324 | 31324L |
| 25/64 | 3-1/4 | 31325 | 31325L |
| 13/32 | 3-5/16 | 31326 | 31326L |
| 27/64 | 3-3/8 | 31327 | 31327L |
| 7/16 | 3-7/16 | 31328 | 31328L |
| 29/64 | 3-9/16 | 31329 | 31329L |
| 15/32 | 3-5/8 | 31330 | 31330L |
| 31/64 | 3-11/16 | 31331 | 31331L |
| 1/2 | 3-3/4 | 31332 | 31332L |

Screw Machine (Stub Length) Drills

Letter Sizes

Features

- 135° Split Point
- Straight Shank
- High Speed Steel
- Surface Treated
- Heavy Duty Construction
- 5 per pack

Heavy Duty Black



| Size | Overall Length | Product Number Right | Product Number Left |
|------|----------------|----------------------|---------------------|
| A | 1-5/16" | 31101 | 31101L |
| B | 1-3/8 | 31102 | 31102L |
| C | 1-3/8 | 31103 | 31103L |
| D | 1-3/8 | 31104 | 31104L |
| E | 1-3/8 | 31105 | 31105L |
| F | 1-7/16 | 31106 | 31106L |
| G | 1-7/16 | 31107 | 31107L |
| H | 1-1/2 | 31108 | 31108L |
| I | 1-1/2 | 31109 | 31109L |

| Size | Overall Length | Product Number Right | Product Number Left |
|------|----------------|----------------------|---------------------|
| J | 1-1/2 | 31110 | 31110L |
| K | 1-1/2 | 31111 | 31111L |
| L | 1-9/16 | 31112 | 31112L |
| M | 1-9/16 | 31113 | 31113L |
| N | 1-5/8 | 31114 | 31114L |
| O | 1-11/16 | 31115 | 31115L |
| P | 1-11/16 | 31116 | 31116L |
| Q | 1-11/16 | 31117 | 31117L |
| R | 1-11/16 | 31118 | 31118L |

| Size | Overall Length | Product Number Right | Product Number Left |
|------|----------------|----------------------|---------------------|
| S | 1-3/4 | 31119 | 31119L |
| T | 1-3/4 | 31120 | 31120L |
| U | 1-13/16 | 31121 | 31121L |
| V | 1-7/8 | 31122 | 31122L |
| W | 1-7/8 | 31123 | 31123L |
| X | 1-15/16 | 31124 | 31124L |
| Y | 1-15/16 | 31125 | 31125L |
| Z | 2 | 31126 | 31126L |

Features

- 135° Split Point
- Surface Treated
- Straight Shank
- Heavy Duty Construction
- High Speed Steel
- 10 per pack

Heavy Duty Black



| Size | Overall Length | Product Number Right | Product Number Left |
|------|----------------|----------------------|---------------------|
| 1 | 2-7/16" | 31201 | 31201L |
| 2 | 2-7/16 | 31202 | 31202L |
| 3 | 2-3/8 | 31203 | 31203L |
| 4 | 2-3/8 | 31204 | 31204L |
| 5 | 2-3/8 | 31205 | 31205L |
| 6 | 2-3/8 | 31206 | 31206L |
| 7 | 2-1/4 | 31207 | 31207L |
| 8 | 2-1/4 | 31208 | 31208L |
| 9 | 2-1/4 | 31209 | 31209L |
| 10 | 2-1/4 | 31210 | 31210L |
| 11 | 2-1/4 | 31211 | 31211L |
| 12 | 2-1/4 | 31212 | 31212L |
| 13 | 2-3/16 | 31213 | 31213L |
| 14 | 2-3/16 | 31214 | 31214L |
| 15 | 2-3/16 | 31215 | 31215L |
| 16 | 2-3/16 | 31216 | 31216L |
| 17 | 2-3/16 | 31217 | 31217L |
| 18 | 2-1/8 | 31218 | 31218L |
| 19 | 2-1/8 | 31219 | 31219L |
| 20 | 2-1/8 | 31220 | 31220L |

| Size | Overall Length | Product Number Right | Product Number Left |
|------|----------------|----------------------|---------------------|
| 21 | 2-1/8" | 31221 | 31221L |
| 22 | 2-1/8 | 31222 | 31222L |
| 23 | 2-1/16 | 31223 | 31223L |
| 24 | 2-1/16 | 31224 | 31224L |
| 25 | 2-1/16 | 31225 | 31225L |
| 26 | 2-1/16 | 31226 | 31226L |
| 27 | 2-1/16 | 31227 | 31227L |
| 28 | 1-15/16 | 31228 | 31228L |
| 29 | 1-15/16 | 31229 | 31229L |
| 30 | 1-15/16 | 31230 | 31230L |
| 31 | 1-7/8 | 31231 | 31231L |
| 32 | 1-7/8 | 31232 | 31232L |
| 33 | 1-7/8 | 31233 | 31233L |
| 34 | 1-7/8 | 31234 | 31234L |
| 35 | 1-7/8 | 31235 | 31235L |
| 36 | 1-13/16 | 31236 | 31236L |
| 37 | 1-13/16 | 31237 | 31237L |
| 38 | 1-13/16 | 31238 | 31238L |
| 39 | 1-13/16 | 31239 | 31239L |
| 40 | 1-13/16 | 31240 | 31240L |

| Size | Overall Length | Product Number Right | Product Number Left |
|------|----------------|----------------------|---------------------|
| 41 | 1-7/8 | 31241 | 31241L |
| 42 | 1-7/8 | 31242 | 31242L |
| 43 | 1-7/8 | 31243 | 31243L |
| 44 | 1-7/8 | 31244 | 31244L |
| 45 | 1-7/8 | 31245 | 31245L |
| 46 | 1-11/16 | 31246 | 31246L |
| 47 | 1-11/16 | 31247 | 31247L |
| 48 | 1-11/16 | 31248 | 31248L |
| 49 | 1-11/16 | 31249 | 31249L |
| 50 | 1-11/16 | 31250 | 31250L |
| 51 | 1-11/16 | 31251 | 31251L |
| 52 | 1-11/16 | 31252 | 31252L |
| 53 | 1-5/8 | 31253 | 31253L |
| 54 | 1-5/8 | 31254 | 31254L |
| 55 | 1-5/8 | 31255 | 31255L |
| 56 | 1-3/8 | 31256 | 31256L |
| 57 | 1-3/8 | 31257 | 31257L |
| 58 | 1-3/8 | 31258 | 31258L |
| 59 | 1-3/8 | 31259 | 31259L |
| 60 | 1-3/8 | 31260 | 31260L |

Technical Information

Screw Machine (Stub Length)

These short length drills feature heavy duty construction and are ideal for use by heating and air conditioning, auto body shops, and sheet metal workers. 135° split points ensures greater ease of penetration, no "walking" and minimum work on extra hard materials. Short flute provides exceptional strength for extra hard material.

Masonry Drills

Carbide Tipped

Features

- Slow Spiral
- Bright Finish
- Industrial Quality
- 10 per pack 5/16" & smaller
- 5 per pack 5/16" to 1/2"
- 1 per pack 9/16" and larger

Slow Spiral Bright



| Size | Overall Length | Shank Diam. | Product Number | |
|-------|----------------|-------------|----------------|--------|
| | | | Bulk | Carded |
| 1/8" | 3" | 1/8" | 32074 | 31608 |
| 5/32 | 4 | 5/32 | 32075 | 31610 |
| 11/64 | 4 | 5/32 | 32076 | 31611 |
| 3/16 | 4 | 3/16 | 32078 | 31612 |
| 3/16 | 6 | 3/16 | 32080 | 33812 |
| 7/32 | 4 | 11/64 | 32081 | 31614 |
| 1/4 | 4 | 1/4 | 32082 | 31616 |
| 1/4 | 6 | 1/4 | 32084 | 33816 |
| 9/32 | 4 | 1/4 | 32085 | 31618 |
| 5/16 | 4 | 1/4 | 32086 | 31620 |
| 5/16 | 6 | 1/4 | 32088 | 33820 |
| 3/8 | 4 | 1/4 | 32090 | 31624 |
| 3/8 | 6 | 3/8 | 32092 | 33824 |
| 7/16 | 4 | 1/4 | - | - |
| 7/16 | 6 | 1/4 | 32094 | 31628 |

| Size | Overall Length | Shank Diam. | Product Number | |
|-------|----------------|-------------|----------------|--------|
| | | | Bulk | Carded |
| 1/2" | 4" | 1/4" | 32095 | 31630 |
| 1/2 | 6 | 1/4 | 32096 | 31632 |
| 1/2 | 6 | 3/8 | 32098 | 33832 |
| 9/16 | 6 | 3/8 | - | 33836 |
| 9/16 | 6 | 1/2 | - | 31636 |
| 5/8 | 6 | 3/8 | - | 33840 |
| 5/8 | 6 | 1/2 | - | 31640 |
| 11/16 | 6 | 1/2 | - | 31644 |
| 3/4 | 6 | 1/2 | - | 31648 |
| 7/8 | 6 | 1/2 | - | 31656 |
| 1 | 6 | 1/2 | - | 31664 |
| 1-1/8 | 6 | 1/2 | - | 31672 |
| 1-1/4 | 6 | 1/2 | - | 31680 |
| 1-3/8 | 6 | 1/2 | - | 31688 |
| 1-1/2 | 6 | 1/2 | - | 31696 |

For drilling in brick, concrete, plaster and other masonry materials. Slow spiral design features wide flutes for better chip and dust removal.

Masonry Drills

Carbide Tipped

Features

- Fast Spiral
- Bright Finish
- Industrial Quality
- 10 per pack 5/16" and smaller
- 5 per pack 5/16" to 1/2"
- 1 per pack 9/16" and larger

Fast Spiral Bright



| Size | Overall Length | Shank Diam. | Product Number | |
|------|----------------|-------------|----------------|--------|
| | | | Bulk | Carded |
| 1/8" | 3" | 1/8" | 32800 | 32008 |
| 3/16 | 4 | 3/16 | 32812 | 32012 |
| 3/16 | 6 | 3/16 | 32813 | 32013 |
| 1/4 | 4 | 1/4 | 32816 | 32016 |
| 1/4 | 6 | 1/4 | 32817 | 32017 |
| 5/16 | 4 | 1/4 | 32820 | 32020 |
| 5/16 | 6 | 1/4 | 32821 | 32021 |
| 3/8 | 4 | 1/4 | 32824 | 32024 |
| 3/8 | 6 | 1/4 | 32825 | 32025 |
| 7/16 | 4 | 1/4 | 32828 | 32028 |
| 7/16 | 6 | 1/4 | 32829 | 32029 |

| Size | Overall Length | Shank Diam. | Product Number | |
|-------|----------------|-------------|----------------|--------|
| | | | Bulk | Carded |
| 1/2" | 4" | 1/4" | 32832 | 32032 |
| 1/2 | 6 | 1/4 | 32833 | 32033 |
| 1/2 | 6 | 3/8 | 32834 | 32034 |
| 9/16 | 6 | 3/8 | - | 32036 |
| 9/16 | 6 | 1/2 | - | 32037 |
| 5/8 | 6 | 3/8 | - | 32040 |
| 5/8 | 6 | 1/2 | - | 32041 |
| 11/16 | 6 | 1/2 | - | 32044 |
| 3/4 | 6 | 1/2 | - | 32048 |
| 7/8 | 6 | 1/2 | - | 32056 |
| 1 | 6 | 1/2 | - | 32064 |

For drilling in brick, concrete, plaster and other masonry materials. Fast spiral design for rapid chip and dust removal. Industrial quality.

Features

- Slow Spiral
- Industrial Quality
- Carbide Tipped
- Black Finish
- 10 per pack 1/4" and smaller
- 5 per pack 5/16" and larger

Slow Spiral Heavy Duty Black



| Size | Overall Length | Shank Diam. | Product Number | |
|------|----------------|-------------|----------------|--------|
| | | | Bulk | Carded |
| 1/8" | 3" | 1/8" | 32508 | 32408 |
| 3/16 | 4 | 3/16 | 32512 | 32412 |
| 3/16 | 6 | 3/16 | 32712 | 32612 |
| 1/4 | 4 | 1/4 | 32516 | 32416 |
| 1/4 | 6 | 1/4 | 32716 | 32616 |
| 5/16 | 4 | 1/4 | 32520 | 32420 |
| 5/16 | 6 | 1/4 | 32720 | 32620 |
| 3/8 | 4 | 1/4 | 32524 | 32424 |
| 3/8 | 6 | 1/4 | 32724 | 32624 |
| 7/16 | 4 | 1/4 | 32528 | 32428 |
| 7/16 | 6 | 1/4 | 32728 | 32628 |

| Size | Overall Length | Shank Diam. | Product Number | |
|-------|----------------|-------------|----------------|--------|
| | | | Bulk | Carded |
| 1/2" | 4" | 1/4" | 32532 | 32432 |
| 1/2 | 6 | 1/4 | 32732 | 32632 |
| 1/2 | 6 | 3/8 | 32734 | 32634 |
| 9/16 | 6 | 3/8 | - | 32636 |
| 9/16 | 6 | 1/2 | - | 32637 |
| 5/8 | 6 | 3/8 | - | 32640 |
| 5/8 | 6 | 1/2 | - | 32641 |
| 11/16 | 6 | 1/2 | - | 32644 |
| 3/4 | 6 | 1/2 | - | 32648 |
| 7/8 | 6 | 1/2 | - | 32656 |
| 1 | 6 | 1/2 | - | 32664 |

For rotary percussion drilling in brick, concrete, plaster and other masonry materials. These rotary percussion type bits are suitable for use in conventional drills and rotary percussion drills equipped with conventional chucks. These bits feature a slow spiral design with wide flutes for better dust removal.

Features

- Heavy Duty
- Rotary Hammer
- Tough Carbide Tip
- Shank meets ANSI specs
- Shank meets European specs
- 1 per pack

SDS Plus Black Finish



| Size | Overall Length | Useable Length | Product Number |
|-------|----------------|----------------|----------------|
| 3/16" | 4" | 2" | 33310 |
| 3/16 | 6 | 4 | 33312 |
| 1/4 | 4 | 2 | 33318 |
| 1/4 | 6 | 4 | 33320 |
| 5/16 | 6 | 4 | 33330 |
| 3/8 | 6 | 4 | 33340 |
| 3/8 | 12 | 10 | 33342 |
| 3/8 | 18 | 16 | 33344 |
| 7/16 | 6 | 4 | 33350 |
| 1/2 | 6 | 4 | 33360 |
| 1/2 | 12 | 10 | 33362 |

| Size | Overall Length | Useable Length | Product Number |
|------|----------------|----------------|----------------|
| 1/2" | 18 | 16" | 33364 |
| 9/16 | 6 | 4 | 33366 |
| 5/8 | 8 | 6 | 33370 |
| 5/8 | 12 | 10 | 33372 |
| 5/8 | 18 | 16 | 33374 |
| 3/4 | 8 | 6 | 33380 |
| 3/4 | 12 | 10 | 33382 |
| 3/4 | 18 | 16 | 33384 |
| 7/8 | 12 | 10 | 33390 |
| 1 | 10 | 10 | 33396 |

- Fits:**
- Hilti® TE-12, TE-17, TE-22
 - Bosch® 11210, 11211, 11212
 - Black & Decker® 5016.09
 - Phillips® 555-715
 - Kango® 327
 - AEG® PH200, PH210, PHE
 - Hitachi® VRT-22A
 - Metabo® 11315
 - Ryobi® ED 211

For rotary hammer drilling in brick, concrete, plaster, and other masonry material. The SDS Plus shank on these drill bits meets both ANSI and European specs and will work with all SDS hammer drills. These bits are loaded with extra features that give outstanding performance.



Masonry Drills

13" Carbide Tipped

Features

- Slow Spiral
- Black Finish
- Industrial Quality
- Drill completely through 12" walls
- Rapid chip and dust removal
- 1 per pack

Slow Spiral Black



| Size | Shank Diam. | Product Number Bulk |
|------|-------------|---------------------|
| 1/4" | 1/4" | 32216 |
| 5/16 | 1/4 | 32220 |
| 3/8 | 3/8 | 32224 |
| 7/16 | 1/4 | 32238 |

| Size | Shank Diam. | Product Number Bulk |
|------|-------------|---------------------|
| 1/2" | 3/8" | 32232 |
| 9/16 | 3/8 | 32236 |
| 5/8 | 3/8 | 32240 |

| Size | Shank Diam. | Product Number Bulk |
|------|-------------|---------------------|
| 3/4" | 1/2" | 32248 |
| 7/8 | 1/2 | 32256 |
| 1 | 1/2 | 32264 |

Masonry Drills

13" Carbide Tipped

Features

- Drill completely through 12" walls
- Rapid chip and dust removal
- 1 per pack

Slow Spiral



| Size | Shank Diam. | Product Number Bulk |
|------|-------------|---------------------|
| 1/4" | 1/4" | 31716 |
| 5/16 | 1/4 | 31720 |
| 3/8 | 1/4 | 31724 |

| Size | Shank Diam. | Product Number Bulk |
|------|-------------|---------------------|
| 1/2" | 3/8" | 31732 |
| 9/16 | 3/8 | 31736 |
| 5/8 | 1/2 | 31740 |

| Size | Shank Diam. | Product Number Bulk |
|------|-------------|---------------------|
| 3/4" | 1/2" | 31748 |
| 7/8 | 1/2 | 31756 |
| 1 | 1/2 | 31764 |

Masonry Drills

"A" Taper Percussion Drills

Features

- For use in hammer drills equipped with shank adapters.
- 1 per pack

Black Finish



| Size | Overall Length | Max. Drilling Depth | Product Number Bulk |
|-------|----------------|---------------------|---------------------|
| 3/16" | 4" | 2 | 32105 |
| 1/4 | 4 | 2 | 32110 |
| 1/4 | 6 | 4 | 32112 |
| 5/16 | 6 | 4 | 32119 |
| 3/8 | 6 | 4 | 32128 |
| 3/8 | 9 | 7 | 32130 |
| 3/8 | 12 | 10 | 32131 |
| 3/8 | 14 | 12 | 32132 |
| 7/16 | 6 | 4 | 32137 |
| 1/2 | 6 | 4 | 32140 |
| 1/2 | 9 | 7 | 32141 |

| Size | Overall Length | Max. Drilling Depth | Product Number Bulk |
|-------|----------------|---------------------|---------------------|
| 1/2" | 14" | 12 | 32143 |
| 1/2 | 20 | 18 | 32145 |
| 9/16 | 6 | 4 | 32148 |
| 9/16 | 9 | 7 | 32149 |
| 5/8 | 6 | 4 | 32152 |
| 5/8 | 9 | 7 | 32154 |
| 5/8 | 12 | 10 | 32155 |
| 11/16 | 6 | 4 | 32157 |
| 11/16 | 9 | 7 | 32158 |
| 3/4 | 6 | 4 | 32160 |
| 3/4 | 9 | 7 | 32161 |

Masonry Drills
1/8" Carbide Tipped

Features

- Slow Spiral
- Black Finish
- Industrial Quality
- Drill through extra thick walls
- Rapid chip and dust removal
- 1 per pack

Slow Spiral Black



| Size | Shank Diam. | Product Number Bulk |
|------|-------------|---------------------|
| 1/4" | 1/4" | 32316 |
| 5/16 | 5/16 | 32320 |
| 3/8 | 3/8 | 32324 |

| Size | Shank Diam. | Product Number Bulk |
|------|-------------|---------------------|
| 1/2" | 3/8" | 32332 |
| 5/8 | 3/8 | 32340 |
| 3/4 | 1/2 | 32348 |

| Size | Shank Diam. | Product Number Bulk |
|------|-------------|---------------------|
| 7/8" | 1/2" | 32356 |
| 1 | 1/2 | 32364 |

Masonry Drills
Rotary Hammer

Features

- Heavy Duty
- Rotary Hammer
- Industrial Quality
- Slow Spiral
- Rapid chip and dust removal
- 5 per pack

Slow Spiral Heavy Duty Black



| Size | Overall Length | Product Number Bulk | Carded | Shank Diam. |
|-------|----------------|---------------------|--------|-------------|
| 1/4" | 4" | 32916 | 33116 | 1/4" |
| 1/4 | 6 | 32918 | 33118 | 1/4 |
| 5/16 | 4 | 32920 | 33120 | 5/16 |
| 5/16" | 6" | 32922 | 33122 | 5/16 |
| 3/8 | 4 | 32924 | 33124 | 3/8 |

| Size | Overall Length | Product Number Bulk | Carded | Shank Diam. |
|------|----------------|---------------------|--------|-------------|
| 3/8 | 6 | 32926 | 33126 | 3/8" |
| 1/2" | 6" | 32932 | 33132 | 3/8 |
| 5/8 | 6 | 32940 | 33140 | 1/2 |
| 3/4 | 6 | 32948 | 33148 | 1/2 |

Masonry Drills
Concrete Screw Anchor Bits

Features

- Tungsten Carbide tipped
- 1 per pack



| Size | Overall Length | Flute Length | Product Number Bulk |
|-------|----------------|--------------|---------------------|
| 5/32" | 3-1/2" | 2" | 33204 |
| 5/32 | 4-1/2 | 3 | 33206 |
| 5/32 | 5-1/2 | 4 | 33208 |

| Size | Overall Length | Flute Length | Product Number Bulk |
|-------|----------------|--------------|---------------------|
| 3/16" | 3-1/2 | 2" | 33210 |
| 3/16 | 4-1/2 | 3 | 33212 |
| 3/16 | 5-1/2 | 3-1/2 | 33214 |

Specially designed for installing masonry screws such as Tapcon®, Uniset, Ramset. The shank on these bits will fit in all tool holders designed for this particular application. The shank has been reinforced at it's weakest point by eliminating the 90° angle between the body and the shank. The tungsten carbide tip will easily penetrate cement block, concrete, or brick walls.

Specialty Drills

Combined Drills and Countersinks

Features

- 60° Included Angle
- Plain Type
- High Speed Steel
- Surface Treated
- 5 per pack



| Size | Drill Diam. | Body Diam. | Overall Length | Product Number |
|------|-------------|------------|----------------|----------------|
| 000 | .020" | 1/8" | 1-1/4" | 40203 |
| 00 | .025 | 1/8 | 1-1/4 | 40205 |
| 0 | 1/32 | 1/8 | 1-1/4 | 40210 |
| 1 | 3/64 | 1/8 | 1-1/4 | 40211 |
| 2 | 5/64 | 3/16 | 1-7/8 | 40212 |
| 3 | 7/64 | 1/4 | 2 | 40213 |

| Size | Drill Diam. | Body Diam. | Overall Length | Product Number |
|------|-------------|------------|----------------|----------------|
| 4 | 1/8" | 5/16" | 2-1/8" | 40214 |
| 5 | 3/16 | 7/16 | 2-3/4 | 40215 |
| 6 | 7/32 | 1/2 | 3 | 40216 |
| 7 | 1/4 | 5/8 | 3-1/4 | 40217 |
| 8 | 5/16 | 3/4 | 3-1/2 | 40218 |

Drill and Tap Set

13 Piece Drill and Tap Set

A time-saving threading set which includes the proper drill bits for each of the taps. Packed in an attractive vinyl display pouch.

Includes: 6 wire gauge 135° split point screw machine length HSS drill bits: Nos. 43, 35, 29, 25, 21, and 7, plus 6 plug taps, 4- 40 NC, 6-32 NC, 8-32 NC, 10-24 NC, 10-32 NF and 1/4-20 NC and a T-Handle tap wrench.



| Description | Product Number |
|-----------------------------------|----------------|
| 13 Piece Drilling and Tapping Set | 41095 |

Miscellaneous Tools

Thread Gauges for Inch and Metric Screws

These gauges quickly tell the size, pitch (threads per inch), tap drill size, clearance drill size, tap series, length and basic diameter for American, Unified or Metric machine screws and bolts.



| Description | Product Number |
|----------------------|----------------|
| Gauge for No.1-5/16" | 51010 |
| Gauge for M2-M7 | 51020 |
| Gauge for M8-M14 | 51030 |

Carbide Tipped · Glass and Tile Drills

Features

- Tungsten carbide tipped and precision diamond ground for drilling glass, ceramic tile and porcelain china.

Bright Finish



| Size | Overall Length | Product Number Bulk | Carded |
|------|----------------|---------------------|--------|
| 1/8" | 3-3/8" | 57008 | 57108 |
| 3/16 | 3-3/8 | 57012 | 57112 |
| 1/4 | 3-3/8 | 57016 | 57116 |

| Size | Overall Length | Product Number Bulk | Carded |
|-------|----------------|---------------------|--------|
| 5/16" | 3-3/8" | 57020 | 57120 |
| 3/8 | 3-3/8 | 57024 | 57124 |
| 1/2 | 3-3/8 | 57032 | 57132 |

Double-End Drills · Fractional and Wire Gage Sizes

Features

- 135° Split Point
- Stub Length
- High Speed Steel
- Surface Treated
- Straight Shank
- 10 per pack

Black Finish



| Size | Overall Length | Fractional Product Number |
|-------|----------------|---------------------------|
| 7/64" | 1-7/8" | 38307 |
| 1/8 | 2 | 38308 |
| 9/64 | 2 | 38309 |
| 5/32 | 2-1/16 | 38310 |
| 3/16 | 2-3/16 | 38312 |
| 7/32 | 2-3/8 | 38314 |
| 1/4 | 2-1/2 | 38316 |

| Size | Overall Length | Wire Gage Product Number |
|------|----------------|--------------------------|
| 11" | 2-1/4 | 38511 |
| 20 | 2-1/8 | 38520 |
| 30 | 2 | 38530 |

These stub length sheet metal drills are especially popular in automotive body work. The shorter flute length adds rigidity. 135° split points ensures greater ease of penetration.

Carbide Tipped · Fractional Sizes

Features

- High Alloy Body
- Carbide Tip
- Tempered Body
- Great for Extra Hardened Steel
- Specially tempered
- 1 per pack

Black Finish



| Size | Dec. Equiv. | Overall Length | Shank Diameter | Product Number |
|------|-------------|----------------|----------------|----------------|
| 1/8" | .1250" | 2-1/2" | 1/8" | 35050 |
| 3/16 | .1875 | 3 | 3/16 | 35056 |
| 7/32 | .2188 | 4 | 7/32 | 35058 |
| 1/4 | .2500 | 4 | 1/4 | 35060 |
| 1/4 | .2500 | 6 | 1/4 | 35061 |

| Size | Dec. Equiv. | Overall Length | Shank Diameter | Product Number |
|-------|-------------|----------------|----------------|----------------|
| 5/16" | .3125" | 4" | 1/4" | 35070 |
| 5/16 | .3125 | 6 | 1/4 | 35071 |
| 3/8 | .3750 | 6 | 3/8 | 35080 |
| 1/2 | .5000 | 6 | 3/8 | 35090 |

These industrial duty bits were developed to penetrate extra hardened steels such as might be encountered in the locksmith trade. A specially tempered body matched with a carbide tip made from an exotic grade of carbide enables these bits to penetrate hard steels up to 65 Rockwell C. When using these bits it is recommended that you use coolant when possible and clear the drill from the hole occasionally. Do not use these bits for drilling in non-ferrous metals, concrete or masonry.



Specialty Drills

Wood Cutting Twist Drills

Features

- Special Center Spur
- Made from special steel alloy
- 3/8" and above have 3/8" reduced shank
- 1 per pack



Special center spur point holds the bit on target, pilots the hole, and prevents walking. Two sharp cutting flutes cut and shave a perfectly round, clean hole. Won't tear the grain, splinter, clog or bind such as all-purpose bits can.

| Size | Overall Length | Product Number Bulk | Product Number Carded |
|------|----------------|---------------------|-----------------------|
| 1/8" | 2-1/2" | 57408 | 57508 |
| 3/16 | 3-3/8 | 57412 | 57512 |
| 1/4 | 4 | 57416 | 57516 |
| 5/16 | 4-1/2 | 57420 | 57520 |
| 3/8 | 5-1/2 | 57424 | 57524 |
| 7/16 | 5-1/2 | 57428 | 57528 |

| Size | Overall Length | Product Number Bulk | Product Number Carded |
|------|----------------|---------------------|-----------------------|
| 1/2" | 6 | 57432 | 57532 |
| 5/8 | 7 | 57440 | 57540 |
| 3/4 | 7-3/4 | 57448 | 57548 |
| 7/8 | 7-3/4 | 57456 | 57556 |
| 1 | 7-3/4 | 57464 | 56564 |

Specialty Drills

Forstner Bits

Features

- Industrial Quality
- 3/8" Shank
- Makes clean smooth holes
- 1 per pack



These industrial quality bits drill perfect, flat bottom holes with very smooth walls. They drill through irregular grain or knots, even end grain. They drill overlapping holes, enlarge existing holes, and drill at an angle.

| Size | Overall Length | Shank | Product Number |
|-------|----------------|-------|----------------|
| 1/4" | 3-1/2" | 3/8" | 57303 |
| 3/8 | 3-1/2 | 3/8 | 57306 |
| 1/2 | 3-1/2 | 3/8 | 57309 |
| 5/8 | 3-1/2 | 3/8 | 57312 |
| 3/4 | 3-1/2 | 3/8 | 57315 |
| 7/8 | 3-1/2 | 3/8 | 57318 |
| 1 | 3-1/2 | 3/8 | 57321 |
| 1-1/8 | 3-1/2 | 3/8 | 57324 |

| Size | Overall Length | Shank | Product Number |
|-------|----------------|-------|----------------|
| 1-1/4 | 3-1/2" | 3/8" | 57327 |
| 1-3/8 | 3-1/2 | 3/8 | 57330 |
| 1-1/2 | 3-1/2 | 3/8 | 57333 |
| 1-5/8 | 3-1/2 | 3/8 | 57336 |
| 1-3/4 | 3-1/2 | 3/8 | 57339 |
| 1-7/8 | 3-1/2 | 3/8 | 57342 |
| 2 | 3-1/2 | 3/8 | 57345 |
| 2-1/8 | 3-1/2 | 3/8 | 57348 |

Specialty Drills

Self-Feed Bits

Features

- Industrial Quality
- 1/2" Shank
- Interchangeable Screw Points
- Fast and precise boring
- Includes 1 extra screw point
- 1 per pack



Designed for fast and precise boring of holes in wood. Ideal for plumbers, electricians, carpenters, and anyone else who needs to drill holes in wood with minimum effort. These bits are made from special high alloy steel and will give better performance and longer life.

| Size | Overall Length | Shank | Product Number |
|-------|----------------|-------|----------------|
| 1" | 6" | 1/2" | 57616 |
| 1-1/8 | 6 | 1/2 | 57618 |
| 1-1/4 | 6 | 1/2 | 57620 |
| 1-3/8 | 6 | 1/2 | 57622 |
| 1-1/2 | 6 | 1/2 | 57624 |
| 1-3/4 | 6 | 1/2 | 57628 |
| 2 | 6" | 1/2" | 57632 |

| Size | Overall Length | Shank | Product Number |
|--------|----------------|-------|----------------|
| 2-1/8 | 6 | 1/2 | 57634 |
| 2-1/4 | 6 | 1/2 | 57636 |
| 2-9/16 | 6 | 1/2 | 57641 |
| 3 | 6 | 1/2 | 57647 |
| 3-5/8 | 6 | 1/2 | 57658 |
| 4-5/8 | 6 | 1/2 | 57674 |

Specialty Drills

Drills for Plastics · Straight Shank

Features

- Straight Shank
- Great for Plexiglas
- Specially Ground Points • 10 per pack 1/4" and smaller
- High Speed Steel
- 5 per pack 9/32" and larger

Bright Finish



| Size | Overall Length | Product Number | |
|------|----------------|----------------|--------|
| | | Bulk | Carded |
| 1/8" | 2-3/4" | 35208 | 35308 |
| 5/32 | 3-1/8 | 35210 | 35310 |
| 3/16 | 3-1/2 | 35212 | 35312 |
| 7/32 | 3-3/4 | 35214 | 35314 |
| 1/4 | 4 | 35216 | 35316 |
| 9/32 | 4-1/4 | 35218 | 35318 |
| 5/16 | 4-1/2 | 35220 | 35320 |

| Size | Overall Length | Product Number | |
|--------|----------------|----------------|--------|
| | | Bulk | Carded |
| 11/32" | 4-3/4 | 35222 | 35322 |
| 3/8 | 5 | 35224 | 35324 |
| 13/32 | 5-1/4 | 35226 | 35326 |
| 7/16 | 5-1/2 | 35228 | 35328 |
| 15/32 | 5-3/4 | 35230 | 35330 |
| 1/2 | 6 | 35232 | 35332 |

These drills have specially ground points that offer superior performance in acrylic plastic sheet and similar materials. These drills will give clean holes without grabbing or cracking the plastic.

Specialty Drills

Drills for Plastics · 1/4" Reduced Shank

Features

- 1/4" Shank
- Great for Plexiglas
- Specially ground points
- Polished Flute
- High Speed Steel
- 5 per pack

Gray Finish



| Size | Overall Length | Product Number | |
|-------|----------------|----------------|--------|
| | | Bulk | Carded |
| 9/32" | 4" | 35418 | 35518 |
| 5/16 | 4 | 35420 | 35520 |
| 11/32 | 4 | 35422 | 35522 |
| 3/8 | 4 | 35424 | 35524 |

| Size | Overall Length | Product Number | |
|--------|----------------|----------------|--------|
| | | Bulk | Carded |
| 13/32" | 4" | 35426 | 35526 |
| 7/16 | 4 | 35428 | 35528 |
| 15/32 | 4 | 35430 | 35530 |
| 1/2 | 4 | 35432 | 35532 |

Specialty Drills

Drills for Plastics · 3/8" Reduced Shank

Features

- 3/8" Shank
- Great for Plexiglas
- Specially ground points
- Polished Flute
- High Speed Steel
- 5 per pack

Bright Finish



| Size | Overall Length | Product Number | |
|--------|----------------|----------------|--------|
| | | Bulk | Carded |
| 13/32" | 5-1/4" | 35626 | 35726 |
| 7/16 | 5-1/2 | 35628 | 35728 |

| Size | Overall Length | Product Number | |
|-------|----------------|----------------|--------|
| | | Bulk | Carded |
| 15/32 | 5-3/4" | 35630 | 35730 |
| 1/2 | 6 | 35632 | 35732 |

Drill Sets

High Speed Steel

13 Piece Sets

- Sizes 1/16-1/4 by 64ths • In Sturdy Metal Index
- Straight Shank
- Jobbers Length

| Description | Product Number |
|------------------|----------------|
| Bright | 34130 |
| Black | 34131 |
| Heavy Duty | 34133 |
| Cobalt | 34132 |
| Titanium Nitride | 34310 |
| Super Duty | 34134 |



Drill Sets

High Speed Steel

15 Piece Sets

- Sizes 1/16-1/2 by 32nds
- Jobbers Length
- In Sturdy Metal Index

| Description | Straight Shank Product Number | 3/8" Shank Product Number | 1/4" Shank Product Number |
|------------------|----------------------------------|------------------------------|------------------------------|
| Bright | 34150 | 34155 | 34160 |
| Black | 34151 | 34156 | 34161 |
| Heavy Duty | 34153 | 34157 | - |
| Cobalt | 34152 | 34158 | - |
| Titanium Nitride | 34314 | 34159 | - |
| Super Duty | 34154 | - | - |



Drill Sets

High Speed Steel

21 Piece Sets

- Sizes 1/16-3/8 by 64ths • In Sturdy Metal Index
- Straight Shank
- Jobbers Length

| Description | Product Number |
|------------------|----------------|
| Bright | 34180 |
| Black | 34181 |
| Heavy Duty | 34183 |
| Cobalt | 34182 |
| Titanium Nitride | 34318 |
| Super Duty | 34184 |



Drill Sets

High Speed Steel

29 Piece Sets

- Sizes 1/16-1/2 by 64ths
- Jobbers Length
- In Sturdy Metal Index

| Description | Straight Shank Product Number | 3/8" Shank Product Number | 1/4" Shank Product Number |
|-----------------------------|----------------------------------|------------------------------|------------------------------|
| Bright | 34200 | 34205 | 34210 |
| Black | 34201 | 34206 | 34211 |
| Heavy Duty | 34203 | - | - |
| Cobalt | 34202 | 34208 | - |
| Titanium Nitride | 34324 | 34209 | - |
| Super Duty | 34204 | - | - |
| Screw Machine (stub) Length | 34424 | - | - |
| Left Hand Bright | 34200L | - | - |



Drill Sets

High Speed Steel

26 Piece Sets

- Letters A-Z
- Jobbers Length
- In Sturdy Metal Index

| Description | Straight Shank Product Number | 3/8" Shank Product Number |
|------------------|----------------------------------|------------------------------|
| Bright | 34215 | 34225 |
| Black | 34216 | - |
| Heavy Duty | 34218 | - |
| Cobalt | 34217 | - |
| Titanium Nitride | 34219 | - |



Drill Sets

High Speed Steel

60 Piece Sets

- No. 1-60
- Straight Shank
- Jobbers Length
- In Sturdy Metal Index

| Description | Straight Shank Product Number |
|-----------------------------|----------------------------------|
| Bright | 34240 |
| Black | 34241 |
| Heavy Duty | 34243 |
| Cobalt | 34242 |
| Screw Machine (stub) Length | 34428 |



Drill Sets

High Speed Steel

80 Piece Sets

- No. 1-80
- Straight Shank
- Jobbers Length
- In Sturdy Metal Index



| Description | Straight Shank Product Number |
|-------------|----------------------------------|
| Bright | 34260 |

Drill Sets

20 Piece Sets

- No. 61-80
- Straight Shank
- Jobbers Length
- In Metal Index



| Description | Product Number |
|-----------------|----------------|
| Metal Index Set | 34245 |

Drill Sets

High Speed Steel

8 Piece Sets

Sizes: 9/16, 5/8, 11/16, 3/4, 13/16, 7/8, 15/16, and 1"

- 6" Overall Length Drills
- In Sturdy Wood Case
- Surface Treated



| Description | Product Number |
|---|----------------|
| 8 Piece set with POSI-GRIP™ shanks (3 flats ground on shanks) | 41508 |
| 8 Piece Cobalt set with POSI-GRIP™ shanks | 42708 |
| 8 Piece set with round shanks | 41708 |
| 8 Piece Cobalt set with round shanks | 42908 |

Drill Sets

Masonry

4 Piece Masonry Drill Sets 1/4-1/2

- Sizes: 1/4, 5/16, 3/8, 1/2
- In vinyl pouch



| Description | Product Number |
|-------------------------------------|----------------|
| Fast Spiral-Bright | 32000 |
| Slow Spiral-Bright | 31600 |
| Slow Spiral-Black Finish-Heavy Duty | 32500 |

High Speed Steel

13 Piece Metric Set

- Straight Shank
- Black Finish
- In Sturdy Metal Index

Sizes: 1.50, 2.00, 2.50, 3.00, 3.30, 3.50, 4.00, 4.20, 4.50, 5.00, 5.50, 6.00, 6.50

| Description | Straight Shank Product Number |
|---------------------|-------------------------------|
| 13 Piece Metric Set | 34280 |



High Speed Steel

25 Piece Metric Set

- Straight Shank
- Black Finish
- In Sturdy Metal Index

Sizes: M1.00 - M13.00 by M0.50

| Description | Straight Shank Product Number |
|---------------------|-------------------------------|
| 25 Piece Metric Set | 34290 |



High Speed Steel

14 Piece Drill Set

- Featuring 14 of the most popular sizes
- In Sturdy Metal Index

Sizes: 1/16, 5/64, 3/32, 7/64, 1/8, 9/64, 5/32, 3/16, 7/32, 1/4, 5/16, 3/8, 7/16 and 1/2

| Description | Straight Shank Product Number | 3/8" Reduced Shank Product Number |
|------------------|-------------------------------|-----------------------------------|
| Bright | 34500 | 34505 |
| Cobalt | 34502 | 34508 |
| Titanium Nitride | 34504 | 34510 |



Drill Sets

High Speed Steel

115 Piece Sets

- Sizes: 1/16-1/2 by 64ths • In Sturdy Metal Index Letters A-Z No. 1-60

| Description | Straight Shank Product Number | 3/8" Shank Product Number |
|-------------|-------------------------------|---------------------------|
| Bright | 34230 | 34236 |
| Black | 34231 | - |
| Heavy Duty | 34233 | - |
| Cobalt | 34232 | - |



134 Piece Sets

- Sizes: 1/16-1/2 by 64ths • In Sturdy Metal Index No. 1-80 M1-M13 by M0.5

| Description | Straight Shank Product Number |
|-------------|-------------------------------|
| Bright | 34460 |

135 Piece Sets

- Sizes: 1/16-1/2 by 64ths • In Sturdy Metal Index Letters A-Z No. 1-80

| Description | Straight Shank Product Number | 3/8" Shank Product Number |
|-------------|-------------------------------|---------------------------|
| Bright | 34450 | 34454 |
| Black | 34452 | - |

Drill Sets

High Speed Steel

10 Piece Set 1/16-1/4

- Sizes: 1/16, 5/64, 3/32, 7/64, 1/8, 9/64, 5/32, 3/16, 7/32, and 1/4"
- In Plastic Index

| Description | Product Number |
|---------------|----------------|
| Bright Finish | 34106 |
| Heavy Duty | 34359 |
| Titanium | 34379 |
| Cobalt | 34369 |



13 Piece Set 1/16-1/4 by 64ths

- Sizes: 1/16, 5/64, 3/32, 7/64, 1/8, 9/64, 5/32, 11/64, 3/16, 13/64, 7/32, 15/64 and 1/4"
- In Plastic Index

| Description | Product Number |
|---------------|----------------|
| Bright Finish | 34110 |
| Heavy Duty | 34363 |
| Titanium | 34383 |
| Cobalt | 34373 |

13 Piece Sets for 1/4" Chucks 1/16-1/2

- Sizes: 1/16, 5/64, 3/32, 7/64, 1/8, 9/64, 5/32, 3/16, 7/32, 1/4 plus 1/4" shank drills in sizes 5/16, 3/8, and 1/2." • In Plastic Index

| Description | Product Number |
|---------------|----------------|
| Bright Finish | 34114 |

14 Piece Sets for 1/4" Chucks 1/16-1/2

- Sizes: 1/16, 5/64, 3/32, 7/64, 1/8, 9/64, 5/32, 3/16, 7/32, 1/4 plus 1/4" shank drills in sizes 5/16, 3/8, 7/16 and 1/2." • In Plastic Index

| Description | Product Number |
|---------------|----------------|
| Bright Finish | 34118 |

**5 Piece Left Hand Screw Machine
(Stub Length Sizes)**

- Sizes: 1/8, 3/16, 1/4, 5/16, and 3/8"
- Straight Shank • In Vinyl Pouch



| Description | Product Number |
|---|----------------|
| 5 Piece Left Hand Drill Set-Stub Length | 34270 |

**15 Piece Bit-Pak™
High Speed Steel Drill Set**

- Sizes 1/16, 5/64, 3/32, 7/64, and 1/8

This set provides three each of the popular sizes 1/16, 5/64, 3/32, 7/64, and 1/8 in a reusable vinyl pouch. These smaller bits are used frequently and having just one of each in a set may not be enough. The busy user will save time by carrying this set rather than continually hunting for an additional bit when he or she needs it.

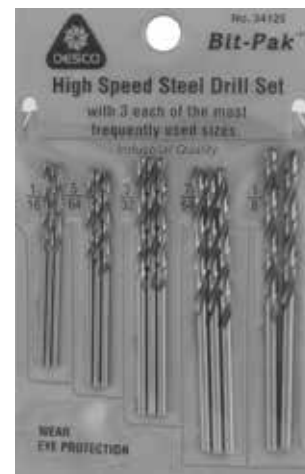

| Description | Product Number |
|-------------------|----------------|
| 15 Piece Bit-Pak™ | 34125 |

13 Piece Dial-A-Drill™ Set

- Sizes 1/16 - 1/4 by 64ths

This set features a round plastic drill index which comes with industrial quality bright jobber drills in sizes 1/16 - 1/4 by 64ths. This set's ease of use and compact size make it the right set for any workbench. A convenient hang up clip is provided with the set for hang-up display.



| Description | Product Number |
|-------------|----------------|
| Bright | 34602 |
| Heavy Duty | 34604 |
| Cobalt | 35606 |



Screw Extractors

Left Hand Spiral Flutes

Features

- Left Hand Spiral
- Sizes 1-12
- Stub Lengths Available upon Request



| Size | Removes Bolts and Screws | Removes Pipe Sizes | Use Drill Size | Product Number | |
|------|--------------------------|--------------------|----------------|----------------|--------|
| | | | | Bulk | Carded |
| 1 | 3/32" to 5/32" | - | 5/64" | 33501 | 33611 |
| 2 | 5/32" to 7/32" | - | 7/64" | 33502 | 33612 |
| 3 | 7/32" to 9/32" | - | 5/32" | 33503 | 33613 |
| 4 | 9/32" to 3/8" | 1/8" | 1/4" | 33504 | 33614 |
| 5 | 3/8" to 5/8" | 1/4" | 19/64" | 33505 | 33615 |
| 6 | 5/8" to 7/8" | 3/8" | 13/32" | 33506 | 33616 |
| 7 | 7/8" to 1-1/8" | 1/2" | 17/32" | 33507 | 33617 |
| 8 | 1-1/8" to 1-3/8" | 3/4" | 13/16" | 33508 | 33618 |
| 9 | 1-3/8" to 2" | 1" | 1-1/16" | 33509 | 33619 |
| 10 | 2-1/8" to 2-1/2" | 1-1/14" | 1-5/16" | 33510 | - |
| 11 | 2-1/2" to 3" | 1-1/2" | 1-9/16" | 33511 | - |
| 12 | 3" to 3-1/2" | 2" | 1-15/16" | 33512 | - |

Screw Extractor Sets

Left Hand Spiral Flute

In sturdy wooden stand

| Product Number | Description |
|----------------|--|
| 33518 | 8 Piece Set-sizes 1, 2, 3, 4, 5, 6, 7 and 8 |
| 33520 | 9 Piece Set-sizes 1, 2, 3, 4, 5, 6, 7, 8 and 9 |



Screw Extractor Sets

Left Hand Spiral Flute

In vinyl display pouch

| Product Number | Description |
|----------------|---------------------------------------|
| 46200 | 4 Piece Set-sizes 2, 3, 4 and 5 |
| 46205 | 5 Piece Set-sizes 1, 2, 3, 4 and 5 |
| 46210 | 6 Piece Set-sizes 1, 2, 3, 4, 5 and 6 |



Features

- Left Hand Spiral
- Sizes 1-7
- Stub Lengths Available upon Request



| Size | Removes Bolts and Screws | Removes Pipe Sizes | Use Drill Size | Product Number Bulk | Carded |
|------|--------------------------|--------------------|----------------|---------------------|--------|
| 1 | 3/16" to 5/16" | - | 9/64" | 33601 | 33701 |
| 2 | 3/8" | - | 3/16" | 33602 | 33702 |
| 3 | 7/16" | 1/8" | 15/64" | 33603 | 33703 |
| 4 | 1/2" to 9/16" | 1/4" | 5/16" | 33604 | 33704 |
| 5 | 5/8" | 3/8" | 3/8" | 33605 | 33705 |
| 6 | 3/4" | 1/2" | 15/32" | 33606 | 33706 |
| 7 | 7/8" | - | 9/16" | 33607 | 33707 |

Screw Extractor Sets

Straight Flute Set

In sturdy wooden stand

| Product Number Bulk | Description |
|---------------------|--|
| 33525 | 7 Piece Set-sizes 1, 2, 3, 4, 5, 6 and 7 |



Screw Extractor Sets

Straight Flute Set

In vinyl display pouches

| Product Number Bulk | Description |
|---------------------|---------------------------------------|
| 46230 | 4 Piece Set-sizes 2, 3, 4 and 5 |
| 46235 | 5 Piece Set-sizes 1, 2, 3, 4 and 5 |
| 46240 | 6 Piece Set-sizes 1, 2, 3, 4, 5 and 6 |



Carbon Steel Taps

Machine Screw

Features

- 5 per pack
- Available in Bulk and Carded
- Tap Wrenches available on page 73



| Size | Bulk Product Number | | | Carded Product Number | | |
|----------|---------------------|-------|--------|-----------------------|-------|--------|
| | Taper | Plug | Bottom | Taper | Plug | Bottom |
| 0-80 NF | 10001 | 10101 | 10201 | - | - | - |
| 1-64 NC | 10003 | 10103 | 10203 | - | - | - |
| 1-72 NF | 10005 | 10105 | 10205 | - | - | - |
| 2-56 NC | 10007 | 10107 | 10207 | - | - | - |
| 2-64 NF | 10009 | 10109 | 10209 | - | - | - |
| 3-48 NC | 10011 | 10111 | 10211 | - | - | - |
| 3-56 NF | 10013 | 10113 | 10213 | - | - | - |
| 4-36 NS | 10015 | 10115 | 10215 | 19000 | 16000 | 20000 |
| 4-40 NC | 10017 | 10117 | 10217 | 19002 | 16002 | 20002 |
| 4-48 NF | 10019 | 10119 | 10219 | - | - | - |
| 5-40 NC | 10021 | 10121 | 10221 | 19006 | 16006 | 20006 |
| 5-44 NF | 10023 | 10123 | 10223 | - | - | - |
| 6-32 NC | 10025 | 10125 | 10225 | 19008 | 16008 | 20008 |
| 6-36 NS | 10027 | 10127 | 10227 | - | - | - |
| 6-40 NF | 10029 | 10129 | 10229 | - | - | - |
| 6-48 NS | 10031 | 10131 | 10231 | - | - | - |
| 8-32 NC | 10033 | 10133 | 10233 | 19014 | 16014 | 20014 |
| 8-36 NF | 10035 | 10135 | 10235 | - | - | - |
| 8-40 NS | 10037 | 10137 | 10237 | - | - | - |
| 10-24 NC | 10039 | 10139 | 10239 | 19018 | 16018 | 20018 |
| 10-32 NF | 10041 | 10141 | 10241 | 19021 | 16021 | 20021 |
| 12-24 NC | 10043 | 10143 | 10243 | 19023 | 16023 | 20023 |
| 12-28 NF | 10045 | 10145 | 10245 | - | - | - |
| 12-32 NF | 10047 | 10147 | 10247 | - | - | - |
| 14-20 NS | 10049 | 10149 | 10249 | 19026 | 16026 | 20026 |
| 14-24 NS | 10051 | 10151 | 10251 | - | - | - |

Technical Information

Taper taps are generally used to create a thread, Plug taps are used to redo the thread and Bottom taps are used to clean the thread.



Features

- 1/2" and smaller 5 per pack
- Larger than 1/2" 1 per pack
- Tap Wrenches available on page 73



| Size | Bulk Product Number | | | Carded Product Number | | |
|-------------|---------------------|-------|--------|-----------------------|-------|--------|
| | Taper | Plug | Bottom | Taper | Plug | Bottom |
| 1/8-40 NS | 10305 | 10405 | 10505 | - | - | - |
| 3/16-24 NS | 10307 | 10407 | 10507 | 19100 | 16100 | 20100 |
| 3/16-32 NS | 10309 | 10409 | 10509 | - | - | - |
| 1/4-20 NC | 10311 | 10411 | 10511 | 19110 | 16110 | 20110 |
| 1/4-24 NS | 10313 | 10413 | 10513 | - | - | - |
| 1/4-28 NF | 10315 | 10415 | 10515 | 19113 | 16113 | 20113 |
| 1/4-32 NEF | 10317 | 10417 | 10517 | - | - | - |
| 1/4-40 NS | 10319 | 10419 | 10519 | - | - | - |
| 5/16-18 NC | 10321 | 10421 | 10521 | 19117 | 16117 | 20117 |
| 5/16-24 NF | 10323 | 10423 | 10523 | 19119 | 16119 | 20119 |
| 5/16-32 NEF | 10325 | 10425 | 10525 | - | - | - |
| 3/8-16 NC | 10327 | 10427 | 10527 | 19124 | 16124 | 20124 |
| 3/8-24 NF | 10329 | 10429 | 10529 | 19126 | 16126 | 20126 |
| 7/16-14 NC | 10331 | 10431 | 10531 | 19129 | 16129 | 20129 |
| 7/16-20 NF | 10333 | 10433 | 10533 | 19131 | 16131 | 20131 |
| 1/2-13 NC | 10335 | 10435 | 10535 | 19135 | 16135 | 20135 |
| 1/2-20 NF | 10337 | 10437 | 10537 | 19137 | 16137 | 20137 |
| 1/2-24 NS | 10339 | 10439 | 10539 | - | - | - |
| 9/16-12 NC | 10341 | 10441 | 10541 | 19140 | 16140 | 20140 |
| 9/16-18 NF | 10343 | 10443 | 10543 | 19142 | 16142 | 20142 |
| 5/8-11 NC | 10345 | 10445 | 10545 | 19144 | 16144 | 20144 |
| 5/8-18 NF | 10347 | 10447 | 10547 | 19146 | 16146 | 20146 |
| 11/16-11 NS | 10349 | 10449 | 10549 | - | - | - |
| 11/16-16 NS | 10351 | 10451 | 10551 | - | - | - |
| 3/4-10 NC | 10353 | 10453 | 10553 | 19148 | 16148 | 20148 |
| 3/4-16 NF | 10355 | 10455 | 10555 | 19150 | 16150 | 20150 |
| 7/8-9 NC | 10357 | 10457 | 10557 | 19152 | 16152 | 20152 |
| 7/8-14 NF | 10359 | 10459 | 10559 | 19154 | 16154 | 20154 |
| 1-8 NC | 10361 | 10461 | 10561 | 19156 | 16156 | 20156 |
| 1-12 NF | 10363 | 10463 | 10563 | 19158 | 16158 | 20158 |
| 1-14 NS | 10365 | 10465 | 10565 | - | - | - |
| 1 1/8-7 NC | 10367 | 10467 | 10567 | - | - | - |
| 1 1/8-12 NF | 10369 | 10469 | 10569 | - | - | - |
| 1 1/4-7 NC | 10371 | 10471 | 10571 | - | - | - |
| 1 1/4-12 NF | 10373 | 10473 | 10573 | - | - | - |
| 1 3/8-6 NC | 10375 | 10475 | 10575 | - | - | - |
| 1 3/8-12 NF | 10377 | 10477 | 10577 | - | - | - |
| 1 1/2-6 NC | 10379 | 10479 | 10579 | - | - | - |
| 1 1/2-12 NF | 10381 | 10481 | 10581 | - | - | - |

Carbon Steel Taps

Pipe Taps

Features

- 1 per pack
- Available in Bulk and Carded
- Tap Wrenches available on page 73



| Size | Product Number | |
|------------------|----------------|--------|
| | Bulk | Carded |
| 1/8-27 NPT | 10910 | 16200 |
| 1/4-18 NPT | 10912 | 16204 |
| 3/8-18 NPT | 10914 | 16206 |
| 1/2-14 NPT | 10916 | 16208 |
| 3/4-14 NPT | 10918 | 16210 |
| 1-11 1/2 NPT | 10920 | 16212 |
| 1 1/4-11 1/2 NPT | 10922 | - |
| 1 1/2-11 1/2 NPT | 10924 | - |

| Size | Product Number | |
|--------------|----------------|--------|
| | Bulk | Carded |
| 2-11 1/2 NPT | 10926 | - |
| 2 1/2-8 NPT | 10928 | - |
| 3-8 NPT | 10930 | - |
| 3 1/2-8 NPT | 10932 | - |
| 4-8 NPT | 10934 | - |
| 1/8-28 BSP | 10950 | - |
| 1/4-19 BSP | 10952 | - |

Carbon Steel Taps

Left Hand Plug Taps · Fractional and Machine Screw Sizes

Features

- All machine sizes 5 per pack
- Fractional up to 1/2" 5 per pack
- Fractional larger than 1/2" 1 per pack



| Machine Size | Product Number |
|--------------|----------------|
| | Bulk |
| 2-56 NC | 10980 |
| 4-40 NC | 10984 |
| 5-40 NC | 10988 |
| 6-32 NC | 10990 |
| 8-32 NC | 10994 |
| 10-24 NC | 10996 |
| 10-32 NF | 10998 |
| 12-24 NC | 11000 |
| 12-28 NF | 11004 |
| 14-20 NS | 11008 |

| Fractional Size | Product Number |
|-----------------|----------------|
| | Bulk |
| 1/4-20 NC | 11010 |
| 1/4-28 NF | 11013 |
| 5/16-18 NC | 11017 |
| 5/16-24 NF | 11019 |
| 3/8-16 NC | 11024 |
| 3/8-24 NF | 11026 |
| 7/16-14 NC | 11029 |
| 7/16-20 NF | 11031 |
| 1/2-13 NC | 11035 |
| 1/2-20 NF | 11037 |

| Fractional Size | Product Number |
|-----------------|----------------|
| | Bulk |
| 9/16-12 NC | 11039 |
| 9/16-18 NF | 11041 |
| 5/8-11 NC | 11043 |
| 5/8-18 NF | 11045 |
| 3/4-10 NC | 11051 |
| 3/4-16 NF | 11053 |
| 7/8-9 NC | 11055 |
| 7/8-14 NF | 11057 |
| 1-8 NC | 11059 |
| 1-14 NS | 11061 |

Features

- 5 per pack M3-M14
- 1 per pack M16 and above
- Available in Bulk and Carded



Bulk

| Size | Bulk Product Number | | | Size | Bulk Product Number | | |
|-----------|---------------------|-------|--------|----------|---------------------|-------|--------|
| | Taper | Plug | Bottom | | Taper | Plug | Bottom |
| M3-0.50 | 10613 | 10713 | 10813 | M16-1.25 | 10669 | 10769 | 10869 |
| M3-0.60 | 10615 | 10715 | 10815 | M16-1.50 | 10670 | 10770 | 10870 |
| M3.5-0.60 | 10617 | 10717 | 10817 | M16-2.00 | 10672 | 10772 | 10872 |
| M4-0.70 | 10619 | 10719 | 10819 | M18-1.50 | 10675 | 10775 | 10875 |
| M4-0.75 | 10620 | 10720 | 10820 | M18-2.50 | 10677 | 10777 | 10877 |
| M4.5-0.75 | 10622 | 10722 | 10822 | M20-1.00 | 10679 | 10779 | 10879 |
| M5-0.80 | 10624 | 10724 | 10824 | M20-1.25 | 10680 | 10780 | 10880 |
| M5-0.90 | 10626 | 10726 | 10826 | M20-1.50 | 10681 | 10781 | 10881 |
| M6-1.00 | 10630 | 10730 | 10830 | M20-2.00 | 10682 | 10782 | 10882 |
| M6.3-1.00 | 10632 | 10732 | 10832 | M20-2.50 | 10683 | 10783 | 10883 |
| M7-1.00 | 10634 | 10734 | 10834 | M22-1.00 | 10685 | 10785 | 10885 |
| M8-1.00 | 10636 | 10736 | 10836 | M22-1.50 | 10687 | 10787 | 10887 |
| M8-1.25 | 10638 | 10738 | 10838 | M22-2.00 | 10688 | 10788 | 10888 |
| M9-0.75 | 10640 | 10740 | 10840 | M22-2.50 | 10689 | 10789 | 10889 |
| M9-1.00 | 10642 | 10742 | 10842 | M24-1.50 | 10691 | 10791 | 10891 |
| M9-1.25 | 10644 | 10744 | 10844 | M24-2.00 | 10692 | 10792 | 10892 |
| M10-1.00 | 10646 | 10746 | 10846 | M24-3.00 | 10695 | 10795 | 10895 |
| M10-1.25 | 10648 | 10748 | 10848 | M27-1.50 | 10697 | 10797 | 10897 |
| M10-1.50 | 10650 | 10750 | 10850 | M27-2.00 | 10698 | 10798 | 10898 |
| M11-1.50 | 10652 | 10752 | 10852 | M27-3.00 | 10700 | 10800 | 10900 |
| M12-1.25 | 10654 | 10754 | 10854 | M30-1.50 | 10701 | 10801 | 10901 |
| M12-1.50 | 10656 | 10756 | 10856 | M30-2.00 | 10702 | 10802 | 10902 |
| M12-1.75 | 10658 | 10758 | 10858 | M30-3.50 | 10703 | 10803 | 10903 |
| M14-1.00 | 10661 | 10761 | 10861 | M32-1.50 | 10704 | 10804 | 10904 |
| M14-1.25 | 10663 | 10763 | 10863 | M33-1.50 | 10705 | 10805 | 10905 |
| M14-1.50 | 10665 | 10765 | 10865 | M33-3.50 | 10706 | 10806 | 10906 |
| M14-2.00 | 10667 | 10767 | 10867 | M34-1.50 | 10707 | 10807 | 10907 |
| M16-1.00 | 10668 | 10768 | 10868 | | | | |

Carded

| Size | Carded Product Number | | Size | Carded Product Number | | Size | Carded Product Number | |
|---------|-----------------------|--------|----------|-----------------------|--------|----------|-----------------------|--------|
| | Plug | Bottom | | Plug | Bottom | | Plug | Bottom |
| M3-0.50 | 16248 | 16328 | M8-1.00 | 16273 | 16353 | M11-1.50 | 16290 | 16370 |
| M3-0.60 | 16250 | 16330 | M8-1.25 | 16275 | 16355 | M12-1.25 | 16292 | 16372 |
| M4-0.70 | 16254 | 16334 | M9-0.75 | 16277 | 16357 | M12-1.50 | 16294 | 16374 |
| M4-0.75 | 16256 | 16336 | M9-1.00 | 16279 | 16359 | M12-1.75 | 16296 | 16376 |
| M5-0.80 | 16262 | 16342 | M9-1.25 | 16281 | 16361 | M14-1.25 | 16298 | 16378 |
| M5-0.90 | 16264 | 16344 | M10-1.00 | 16283 | 16363 | M14-1.50 | 16300 | 16380 |
| M6-1.00 | 16267 | 16347 | M10-1.25 | 16285 | 16365 | M14-2.00 | 16302 | 16382 |
| M7-1.00 | 16271 | 16351 | M10-1.50 | 16287 | 16367 | | | |

High Speed Steel Taps

Cut Thread · Machine Screw Length and Fractional Sizes

Features

- Individually packed
- Available in Bulk and Carded
- Tap Wrenches available on page 73



| Size | No. of Flutes | Pitch Diam. Limits | Bulk Product Number | | | Carded Product Number | | Tap Set |
|------------|---------------|--------------------|---------------------|-------|--------|-----------------------|--------|---------|
| | | | Taper | Plug | Bottom | Plug | Bottom | |
| 4-36 NS | 3 | H2 | 22108 | 22308 | 22508 | 21708 | 21808 | 25202 |
| 4-40 NC | 3 | H2 | 22109 | 22309 | 22509 | 21709 | 21809 | 25203 |
| 4-48 NF | 3 | H2 | 22110 | 22310 | 22510 | - | - | 25204 |
| 5-40 NC | 3 | H2 | 22111 | 22311 | 22511 | 21711 | 21811 | 25205 |
| 5-44 NF | 3 | H2 | 22112 | 22312 | 22512 | - | - | 25206 |
| 6-32 NC | 3 | H3 | 22113 | 22313 | 22513 | 21713 | 21813 | 25207 |
| 6-40 NF | 3 | H2 | 22114 | 22314 | 22514 | - | - | 25208 |
| 8-32 NC | 4 | H3 | 22115 | 22315 | 22515 | 21715 | 21815 | 25210 |
| 8-36 NF | 4 | H2 | 22116 | 22316 | 22516 | - | - | 25211 |
| 10-24 NC | 4 | H3 | 22118 | 22318 | 22518 | 21718 | 21818 | 25213 |
| 10-32 NF | 4 | H3 | 22119 | 22319 | 22519 | 21719 | 21819 | 25214 |
| 12-24 NC | 4 | H3 | 22120 | 22320 | 22520 | 21720 | 21820 | 25215 |
| 12-28 NF | 4 | H3 | 22121 | 22321 | 22521 | - | - | 25216 |
| 1/4-20 NC | 4 | H3 | 22130 | 22330 | 22530 | 21730 | 21830 | 25220 |
| 1/4-28 NF | 4 | H3 | 22131 | 22331 | 22531 | 21731 | 21831 | 25221 |
| 5/16-18 NC | 4 | H3 | 22132 | 22332 | 22532 | 21732 | 21832 | 25222 |
| 5/16-24 NF | 4 | H3 | 22133 | 22333 | 22533 | 21733 | 21833 | 25223 |
| 3/8-16 NC | 4 | H3 | 22134 | 22334 | 22534 | 21734 | 21834 | 25224 |
| 3/8-24 NF | 4 | H3 | 22135 | 22335 | 22535 | 21735 | 21835 | 25225 |
| 7/16-14 NC | 4 | H3 | 22136 | 22336 | 22536 | 21736 | 21836 | 25226 |
| 7/16-20 NF | 4 | H3 | 22137 | 22337 | 22537 | 21737 | 21837 | 25227 |
| 1/2-13 NC | 4 | H3 | 22138 | 22338 | 22538 | 21738 | 21838 | 25228 |
| 1/2-20 NF | 4 | H3 | 22139 | 22339 | 22539 | 21739 | 21839 | 25229 |
| 9/16-12 NC | 4 | H3 | 22140 | 22340 | 22540 | - | - | 25230 |
| 9/16-18 NF | 4 | H3 | 22141 | 22341 | 22541 | - | - | 25231 |
| 5/8-11 NC | 4 | H3 | 22142 | 22342 | 22542 | - | - | 25232 |
| 5/8-18 NF | 4 | H3 | 22143 | 22343 | 22543 | - | - | 25233 |
| 3/4-10 NC | 4 | H3 | 22144 | 22344 | 22544 | - | - | 25234 |
| 3/4-16 NF | 4 | H3 | 22145 | 22345 | 22545 | - | - | 25235 |
| 7/8-9 NC | 4 | H4 | 22146 | 22346 | 22546 | - | - | 25236 |
| 7/8-14 NF | 4 | H4 | 22147 | 22347 | 22547 | - | - | 25237 |
| 1-8 NC | 4 | H4 | 22148 | 22348 | 22548 | - | - | 25238 |
| 1-12 NF | 4 | H4 | 22149 | 22349 | 22549 | - | - | 25239 |
| 1-14 NS | 4 | H4 | 22150 | 22350 | 22550 | - | - | 25240 |

High Speed Steel Taps Cut Thread · Spiral Point

Features

- Individually packed
- For tapping through holes
- Available in Bulk and Carded



| Size | No. of Flutes | Bulk | Carded |
|------------|---------------|-------|--------|
| 4-40 NC | 2 | 24308 | 21908 |
| 5-40 NC | 2 | 24311 | 21911 |
| 6-32 NC | 2 | 24313 | 21913 |
| 8-32 NC | 2 | 24315 | 21915 |
| 10-24 NC | 2 | 24318 | 21918 |
| 10-32 NF | 2 | 24319 | 21919 |
| 12-24 NC | 2 | 24320 | 21920 |
| 12-28 NF | 2 | 24321 | 21921 |
| 1/4-20 NC | 2 | 24330 | 21930 |
| 1/4-28 NF | 2 | 24331 | 21931 |
| 5/16-18 NC | 2 | 24332 | 21932 |
| 5/16-24 NF | 2 | 24333 | 21933 |

| Size | No. of Flutes | Bulk | Carded |
|------------|---------------|-------|--------|
| 3/8-16 NC | 3 | 24334 | 21934 |
| 3/8-24 NF | 3 | 24335 | 21935 |
| 7/16-14 NC | 3 | 24336 | 21936 |
| 7/16-20 NF | 3 | 24337 | 21937 |
| 1/2-13 NC | 3 | 24338 | 21938 |
| 1/2-20 NF | 3 | 24339 | 21939 |
| 9/16-12 NC | 3 | 24340 | - |
| 9/16-18 NF | 3 | 24341 | - |
| 5/8-11 NC | 3 | 24342 | - |
| 5/8-18 NF | 3 | 24343 | - |
| 3/4-10 NC | 3 | 24344 | - |
| 3/4-16 NF | 3 | 24345 | - |

High Speed Steel Taps National Pipe Taper

Features

- Individually packed
- Available in Bulk and Carded



| Size | Bulk | Carded |
|------------|-------|--------|
| 1/8-27 NPT | 25600 | 22100 |
| 1/4-18 NPT | 25601 | 22101 |
| 3/8-18 NPT | 25602 | 22102 |
| 1/2-14 NPT | 25603 | 22103 |
| 3/4-14 NPT | 25604 | - |

| Size | Bulk | Carded |
|------------------|-------|--------|
| 1-11 1/2 NPT | 25605 | - |
| 1 1/4-11 1/2 NPT | 25606 | - |
| 1 1/2-11 1/2 NPT | 25607 | - |
| 2-11 1/2 NPT | 25608 | - |

High Speed Steel Ground Thread Taps

Machine Screw Sizes · Straight Flute

Features

- Individually packed
- Available in Taper, Plug, and Bottom
- Tap Wrenches available on page 73



| Size | No. of Flutes | Pitch Diam. Limits | Bulk Product Number | | |
|---------|---------------|--------------------|---------------------|--------|--------|
| | | | Taper | Plug | Bottom |
| 0-80 NF | 2 | H1* | 500100 | 503100 | 506100 |
| | 2 | H2 | 500102 | 503102 | 506102 |
| 1-64 NC | 2 | H1* | 500104 | 503104 | 506104 |
| | 2 | H2 | 500106 | 503106 | 506106 |
| 1-72 NF | 2 | H1* | 500108 | 503108 | 506108 |
| | 2 | H2 | 500110 | 503110 | 506110 |
| 2-56 NC | 3 | H1* | 500112 | 503112 | 506112 |
| | 3 | H2 | 500114 | 503114 | 506114 |
| 2-64 NF | 3 | H1* | 500116 | 503116 | 506116 |
| | 3 | H2 | 500118 | 503118 | 506118 |
| 3-48 NC | 3 | H1* | 500120 | 503120 | 506120 |
| | 3 | H2 | 500122 | 503122 | 506122 |
| 3-56 NF | 3 | H1* | 500124 | 503124 | 506124 |
| | 3 | H2 | 500126 | 503126 | 506126 |
| 4-40 NC | 3 | H1 | 500128 | 503128 | 506128 |
| | 3 | H2* | 500130 | 503130 | 506130 |
| | 3 | H6 | 500132 | 503132 | 506132 |
| | 3 | H7 | 500134 | 503134 | 506134 |
| 4-48 NF | 3 | H1 | 500136 | 503136 | 506136 |
| | 3 | H2* | 500138 | 503138 | 506138 |
| | 3 | H6 | 500140 | 503140 | 506140 |
| | 3 | H7 | 500142 | 503142 | 506142 |
| 4-36 NS | 3 | H1 | 500144 | 503144 | 506144 |
| | 3 | H2* | 500146 | 503146 | 506146 |
| 5-40 NC | 3 | H1 | 500148 | 503148 | 506148 |
| | 3 | H2* | 500150 | 503150 | 506150 |
| | 3 | H6 | 500152 | 503152 | 506152 |
| | 3 | H7 | 500154 | 503154 | 506154 |
| 5-44 NF | 3 | H1 | 500156 | 503156 | 506156 |
| | 3 | H2* | 500158 | 503158 | 506158 |
| 6-32 NC | 3 | H6 | 500160 | 503160 | 506160 |
| | 3 | H1 | 500164 | 503164 | 506164 |
| | 3 | H2 | 500166 | 503166 | 506166 |
| | 3 | H3* | 500168 | 503168 | 506168 |
| | 3 | H6 | - | 503170 | 506170 |
| | 3 | H7 | - | 503172 | 506172 |

*Considered Standard

| Size | No. of Flutes | Pitch Diam. Limits | Bulk Product Number | | | |
|----------|---------------|--------------------|---------------------|--------|--------|--------|
| | | | Taper | Plug | Bottom | |
| 6-40 NF | 3 | H1 | 500174 | 503174 | 506174 | |
| | 3 | H2* | 500176 | 503176 | 506176 | |
| | 3 | H6 | - | 503178 | 506178 | |
| | 3 | H7 | - | 503180 | 506180 | |
| | 8-32 NC | 4 | H1 | 500182 | 503182 | 506182 |
| | 4 | H2 | 500184 | 503184 | 506184 | |
| | 4 | H3* | 500186 | 503186 | 506186 | |
| | 4 | H6 | 500188 | 503188 | 506188 | |
| | 4 | H7 | 500190 | 503190 | 506190 | |
| 8-36 NF | 4 | H1 | 500192 | 503192 | 506192 | |
| | 4 | H2* | 500194 | 503194 | 506194 | |
| | 3 | H6 | - | 503198 | 506198 | |
| | 3 | H7 | - | 503200 | 506200 | |
| | 10-24 NC | 4 | H1 | 500206 | 503206 | 506206 |
| | 4 | H2 | 500208 | 503208 | 506208 | |
| | 4 | H3* | 500210 | 503210 | 506210 | |
| | 3 | H6 | - | 503212 | 506212 | |
| | 3 | H7 | - | 503214 | 506214 | |
| 10-32 NF | 4 | H1 | 500216 | 503216 | 506216 | |
| | 4 | H2 | 500218 | 503218 | 506218 | |
| | 4 | H3* | 500220 | 503220 | 506220 | |
| | 3 | H6 | - | 503222 | 506222 | |
| | 3 | H7 | - | 503224 | 506224 | |
| | 12-24 NC | 4 | H1 | 500226 | 503226 | 506226 |
| | 4 | H3* | 500228 | 503228 | 506228 | |
| | 12-28 NF | 4 | H1 | 500230 | 503230 | 506230 |
| | 4 | H3* | 500232 | 503232 | 506232 | |
| | 14-20 NS | 4 | H3 | 500234 | 503234 | 506234 |
| 14-24 NS | 4 | H3 | 500235 | 503235 | 506235 | |



Features

- Individually packed
- Optional two or three flute
- Tap Wrenches available on page 73



Optional Two Flute

| Size | No. of Flutes | Pitch Diam. Limits | Bulk Product Number | | |
|---------|---------------|--------------------|---------------------|--------|--------|
| | | | Taper | Plug | Bottom |
| 2-56 NC | 2 | H1 | 510112 | 513112 | 516112 |
| | 2 | H2* | 510144 | 513144 | 516144 |
| 2-64 NF | 2 | H1 | 510116 | 513116 | 516116 |
| | 2 | H2* | 510118 | 513118 | 516118 |
| 3-48 NC | 2 | H1 | 510120 | 513120 | 516120 |
| | 2 | H2* | 510122 | 513122 | 516122 |
| 3-56 NF | 2 | H1 | 510124 | 513124 | 516124 |
| | 2 | H2* | 510126 | 513126 | 516126 |
| 4-40 NC | 2 | H1 | 510128 | 513128 | 516128 |
| | 2 | H2* | 510130 | 513130 | 516130 |
| 4-48 NF | 2 | H1 | 510136 | 513136 | 516136 |
| | 2 | H2* | 510138 | 513138 | 516138 |
| 4-36 NS | 2 | H1 | 510144 | 513144 | 516144 |
| | 2 | H2* | 510146 | 513146 | 516146 |
| 5-40 NC | 2 | H1 | 510148 | 513148 | 516148 |
| | 2 | H2* | 510150 | 513150 | 516150 |

| Size | No. of Flutes | Pitch Diam. Limits | Bulk Product Number | | |
|----------|---------------|--------------------|---------------------|--------|--------|
| | | | Taper | Plug | Bottom |
| 5-44 NF | 2 | H1 | 510156 | 513156 | 516156 |
| | 2 | H2* | 510158 | 513158 | 516158 |
| 6-32 NC | 2 | H1 | 510164 | 513164 | 516164 |
| | 2 | H2 | 510166 | 513166 | 516166 |
| 6-40 NF | 2 | H3* | 510168 | 513168 | 516168 |
| | 2 | H1 | 510174 | 513174 | 516174 |
| 8-32 NC | 2 | H2* | 510176 | 513176 | 516176 |
| | 2 | H1 | 510182 | 513182 | 516182 |
| 8-36 NF | 2 | H2 | 510184 | 513184 | 516184 |
| | 2 | H3* | 510186 | 513186 | 516186 |
| 10-24 NC | 2 | H1 | 510192 | 513192 | 516192 |
| | 2 | H2* | 510194 | 513194 | 516194 |
| 10-32 NF | 2 | H1 | 510204 | 513204 | 516204 |
| | 2 | H2 | 510206 | 513206 | 516206 |
| 10-32 NF | 2 | H3* | 510208 | 513208 | 516208 |
| | 2 | H1 | 510214 | 513214 | 516214 |
| | 2 | H2* | 510216 | 513216 | 516216 |

Optional Three Flute

| Size | No. of Flutes | Pitch Diam. Limits | Bulk Product Number | | |
|---------|---------------|--------------------|---------------------|--------|--------|
| | | | Taper | Plug | Bottom |
| 8-32 NC | 3 | H1 | 520182 | 523182 | 526182 |
| | 3 | H2 | 520184 | 523184 | 526184 |
| | 3 | H3* | 520186 | 523186 | 526186 |
| 8-36 NF | 3 | H1 | 520192 | 523192 | 526192 |
| | 3 | H2* | 520194 | 523194 | 526194 |

| Size | No. of Flutes | Pitch Diam. Limits | Bulk Product Number | | |
|----------|---------------|--------------------|---------------------|--------|--------|
| | | | Taper | Plug | Bottom |
| 10-24 NC | 3 | H1 | 520204 | 523204 | 526204 |
| | 3 | H2 | 520206 | 523206 | 526206 |
| | 3 | H3* | 520208 | 523208 | 526208 |
| 10-32 NF | 3 | H1 | 520214 | 523214 | 526214 |
| | 3 | H2 | 520216 | 523216 | 526216 |
| | 3 | H3* | 520218 | 523218 | 526218 |



High Speed Steel Ground Thread Taps

Fractional Sizes · Straight Flute

Features

- Individually packed
- Available in Taper, Plug, and Bottom



| Size | No. of Flutes | Pitch Diam. Limits | Bulk Product Number | | |
|------------|---------------|--------------------|---------------------|--------|--------|
| | | | Taper | Plug | Bottom |
| 1/4-20 NC | 4 | H1 | 500236 | 503236 | 506236 |
| | 4 | H2 | 500238 | 503238 | 506238 |
| | 4 | H3* | 500240 | 503240 | 506240 |
| | 4 | H5 | 500242 | 503242 | 506242 |
| 1/4-28 NF | 4 | H1 | 500244 | 503244 | 506244 |
| | 4 | H2 | 500246 | 503246 | 506246 |
| | 4 | H3* | 500248 | 503248 | 506248 |
| | 4 | H4 | 500250 | 503250 | 506250 |
| 5/16-18 NC | 4 | H1 | 500252 | 503252 | 506252 |
| | 4 | H2 | 500254 | 503254 | 506254 |
| | 4 | H3* | 500256 | 503256 | 506256 |
| | 4 | H5 | 500258 | 503258 | 506258 |
| 5/16-24 NF | 4 | H1 | 500260 | 503260 | 506260 |
| | 4 | H2 | 500262 | 503262 | 506262 |
| | 4 | H3* | 500264 | 503264 | 506264 |
| | 4 | H4 | 500266 | 503266 | 506266 |
| 3/8-16 NC | 4 | H1 | 500268 | 503268 | 506268 |
| | 4 | H2 | 500270 | 503270 | 506270 |
| | 4 | H3* | 500272 | 503272 | 506272 |
| | 4 | H5 | 500274 | 503274 | 506274 |
| 3/8-24 NF | 4 | H1 | 500276 | 503276 | 506276 |
| | 4 | H2 | 500278 | 503278 | 506278 |
| | 4 | H3* | 500280 | 503280 | 506280 |
| | 4 | H4 | 500282 | 503282 | 506282 |
| 7/16-14 NC | 4 | H1 | 500284 | 503284 | 506284 |
| | 4 | H2 | 500286 | 503286 | 506286 |
| | 4 | H3* | 500288 | 503288 | 506288 |
| | 4 | H5 | 500290 | 503290 | 506290 |
| 7/16-20 NF | 4 | H1 | 500292 | 503292 | 506292 |
| | 4 | H2 | 500294 | 503294 | 506294 |
| | 4 | H3* | 500296 | 503296 | 506296 |
| | 4 | H5 | 500298 | 503298 | 506298 |
| 1/2-13 NC | 4 | H1 | 500300 | 503300 | 506300 |
| | 4 | H2 | 500302 | 503302 | 506302 |
| | 4 | H3* | 500304 | 503304 | 506304 |
| | 4 | H5 | 500306 | 503306 | 506306 |
| 1/2-20 NF | 4 | H1 | 500308 | 503308 | 506308 |
| | 4 | H2 | 500310 | 503310 | 506310 |
| | 4 | H3* | 500312 | 503312 | 506312 |
| | 4 | H5 | 500314 | 503314 | 506314 |
| 9/16-12 NC | 4 | H1 | 500316 | 503316 | 506316 |
| | 4 | H2 | 500318 | 503318 | 506318 |
| | 4 | H3* | 500320 | 503320 | 506320 |
| | 4 | H5 | 500322 | 503322 | 506322 |
| 9/16-18 NF | 4 | H1 | 500324 | 503324 | 506324 |
| | 4 | H2 | 500326 | 503326 | 506326 |
| | 4 | H3* | 500328 | 503328 | 506328 |
| | 4 | H5 | 500330 | 503330 | 506330 |
| 5/8-11 NC | 4 | H1 | 500332 | 503332 | 506332 |
| | 4 | H2 | 500334 | 503334 | 506334 |
| | 4 | H3* | 500336 | 503336 | 506336 |
| | 4 | H5 | 500338 | 503338 | 506338 |

| Size | No. of Flutes | Pitch Diam. Limits | Bulk Product Number | | |
|-------------|---------------|--------------------|---------------------|--------|--------|
| | | | Taper | Plug | Bottom |
| 5/8-18 NF | 4 | H1 | 500340 | 503340 | 506340 |
| | 4 | H2 | 500342 | 503342 | 506342 |
| | 4 | H3* | 500344 | 503344 | 506344 |
| | 4 | H5 | 500346 | 503346 | 506346 |
| 11/16-11 NS | 4 | H3 | 500348 | 503348 | 506348 |
| 11/16-16 NS | 4 | H3 | 500350 | 503350 | 506350 |
| 3/4-10 NC | 4 | H1 | 500352 | 503352 | 506352 |
| | 4 | H2 | 500354 | 503354 | 506354 |
| | 4 | H3* | 500356 | 503356 | 506356 |
| | 4 | H5 | 500358 | 503358 | 506358 |
| 3/4-16 NF | 4 | H1 | 500360 | 503360 | 506360 |
| | 4 | H2 | 500362 | 503362 | 506362 |
| | 4 | H3* | 500364 | 503364 | 506364 |
| | 4 | H5 | 500366 | 503366 | 506366 |
| 7/8-9 NC | 4 | H1 | 500368 | 503368 | 506368 |
| | 4 | H2 | 500370 | 503370 | 506370 |
| | 4 | H4* | 500372 | 503372 | 506372 |
| | 4 | H6 | 500374 | 503374 | 506374 |
| 7/8-14 NF | 4 | H1 | 500376 | 503376 | 506376 |
| | 4 | H2 | 500378 | 503378 | 506378 |
| | 4 | H4* | 500380 | 503380 | 506380 |
| | 4 | H6 | 500382 | 503382 | 506382 |
| 1-8 NC | 4 | H1 | 500384 | 503384 | 506384 |
| | 4 | H2 | 500386 | 503386 | 506386 |
| | 4 | H4* | 500388 | 503388 | 506388 |
| | 4 | H6 | 500390 | 503390 | 506390 |
| 1-12 NF | 4 | H1 | 500392 | 503392 | 506392 |
| | 4 | H2 | 500394 | 503394 | 506394 |
| | 4 | H4* | 500396 | 503396 | 506396 |
| | 4 | H6 | 500398 | 503398 | 506398 |
| 1-14 NS | 4 | H1 | 500400 | 503400 | 506400 |
| | 4 | H2 | 500402 | 503402 | 506402 |
| | 4 | H4* | 500404 | 503404 | 506404 |
| | 4 | H6 | 500406 | 503406 | 506406 |
| 1 1/8-7 NC | 4 | H4* | 500408 | 503408 | 506408 |
| | 4 | H8 | 500410 | 503410 | 506410 |
| 1 1/8-12 NF | 4 | H4* | 500412 | 503412 | 506412 |
| | 4 | H6 | 500414 | 503414 | 506414 |
| 1 1/4-7 NC | 4 | H4* | 500416 | 503416 | 506416 |
| | 4 | H8 | 500418 | 503418 | 506418 |
| 1 1/4-12 NF | 6 | H4* | 500420 | 503420 | 506420 |
| | 6 | H6 | 500422 | 503422 | 506422 |
| 1 3/8-6 NC | 4 | H4* | 500424 | 503424 | 506424 |
| | 4 | H8 | 500426 | 503426 | 506426 |
| 1 3/8-12 NF | 6 | H4* | 500428 | 503428 | 506428 |
| | 6 | H6 | 500430 | 503430 | 506430 |
| 1 1/2-6 NC | 4 | H4* | 500432 | 503432 | 506432 |
| | 4 | H8 | 500434 | 503434 | 506434 |
| 1 1/2-12 NF | 6 | H4* | 500436 | 503436 | 506436 |
| | 6 | H6 | 500438 | 503438 | 506438 |

*Considered Standard



Features

- Individually packed
- Optional two and three flutes



Optional Two Flute

| Size | No. of Flutes | Pitch Diam. Limits | Bulk Product Number | | | Size | No. of Flutes | Pitch Diam. Limits | Bulk Product Number | | |
|-----------|---------------|--------------------|---------------------|--------|--------|------------|---------------|--------------------|---------------------|--------|--------|
| | | | Taper | Plug | Bottom | | | | Taper | Plug | Bottom |
| 1/4-20 NC | 2 | H1 | 510236 | 513236 | 516236 | 5/16-18 NC | 2 | H1 | 510252 | 513252 | 516252 |
| | | H2 | 510238 | 513238 | 516238 | | | H2 | 510254 | 513254 | 516254 |
| | 2 | H3* | 510240 | 513240 | 516240 | 2 | H3* | 510256 | 513256 | 516256 | |
| | | H5 | 510242 | 513242 | 516242 | | H5 | 510258 | 513258 | 516258 | |
| 1/4-28 NF | 2 | H1 | 510244 | 513244 | 516244 | 5/16-24 NF | 2 | H1 | 510260 | 513260 | 516260 |
| | | H2 | 510246 | 513246 | 516246 | | | H2 | 510262 | 513262 | 516262 |
| | | H3* | 510248 | 513248 | 516248 | | | H3* | 510264 | 513264 | 516264 |
| | | | | | | | H4 | 510266 | 513266 | 516266 | |

Optional Three Flute

| Size | No. of Flutes | Pitch Diam. Limits | Bulk Product Number | | | Size | No. of Flutes | Pitch Diam. Limits | Bulk Product Number | | |
|------------|---------------|--------------------|---------------------|--------|--------|------------|---------------|--------------------|---------------------|--------|--------|
| | | | Taper | Plug | Bottom | | | | Taper | Plug | Bottom |
| 1/4-20 NC | 3 | H1 | 520236 | 523236 | 526236 | 3/8-24 NF | 3 | H1 | 520276 | 523276 | 526276 |
| | | H2 | 520238 | 523238 | 526238 | | | H2 | 520278 | 523278 | 526278 |
| | 3 | H3* | 520240 | 523240 | 526240 | 3 | H3* | 520280 | 523280 | 526280 | |
| | | H5 | 520242 | 523242 | 526242 | | H4 | 520282 | 523282 | 526282 | |
| 1/4-28 NF | 3 | H1 | 520244 | 523244 | 526244 | 7/16-14 NC | 3 | H1 | 520284 | 523284 | 526284 |
| | | H2 | 520246 | 523246 | 526246 | | | H2 | 520286 | 523286 | 526286 |
| | 3 | H3* | 520248 | 523248 | 526248 | 3 | H3* | 520288 | 523288 | 526288 | |
| | | H4 | 520250 | 523250 | 526250 | | H5 | 520290 | 523290 | 526290 | |
| 5/16-18 NC | 3 | H1 | 520252 | 523252 | 526252 | 7/16-20 NF | 3 | H1 | 520292 | 523292 | 526292 |
| | | H2 | 520254 | 523254 | 526254 | | | H2 | 520294 | 523294 | 526294 |
| | 3 | H3* | 520256 | 523256 | 526256 | 3 | H3* | 520296 | 523296 | 526296 | |
| | | H5 | 520258 | 523258 | 526258 | | H5 | 520298 | 523298 | 526298 | |
| 5/16-24 NF | 3 | H1 | 520260 | 523260 | 526260 | 1/2-13 NC | 3 | H1 | 520300 | 523300 | 526300 |
| | | H2 | 520262 | 523262 | 526262 | | | H2 | 520302 | 523302 | 526302 |
| | 3 | H3* | 520264 | 523264 | 526264 | 3 | H3* | 520304 | 523304 | 526304 | |
| | | H4 | 520266 | 523266 | 526266 | | H5 | 520306 | 523306 | 526306 | |
| 3/8-16 NC | 3 | H1 | 520268 | 523268 | 526268 | 1/2-20 NF | 3 | H1 | 520308 | 523308 | 526308 |
| | | H2 | 520270 | 523270 | 526270 | | | H2 | 520310 | 523310 | 526310 |
| | 3 | H3* | 520272 | 523272 | 526272 | 3 | H3* | 520312 | 523312 | 526312 | |
| | | H5 | 520274 | 523274 | 526274 | | H5 | 520314 | 523314 | 526314 | |

*Considered Standard

High Speed Steel Ground Thread Taps

Spiral Point (Chip Driver) · Machine Screw Sizes · Straight Flute

← Features →

- Individually packed
- Available in Plug and Bottom



| Size | No. of Flutes | Pitch Diam. Limits | Bulk Product Number | |
|---------|---------------|--------------------|---------------------|--------|
| | | | Plug | Bottom |
| 0-80 NF | 2 | H1* | 533100 | 536100 |
| | 2 | H2 | 533102 | 536102 |
| 1-64 NC | 2 | H1* | 533104 | 536104 |
| | 2 | H2 | 533106 | 536106 |
| 1-72 NF | 2 | H1* | 533108 | 536108 |
| | 2 | H2 | 533110 | 536110 |
| 2-56 NC | 2 | H1* | 533112 | 536112 |
| | 2 | H2 | 533114 | 536114 |
| 2-64 NF | 2 | H1* | 533116 | 536116 |
| | 2 | H2 | 533118 | 536118 |
| 3-48 NC | 2 | H1* | 533120 | 536120 |
| | 2 | H2 | 533122 | 536122 |
| 3-56 NF | 2 | H1* | 533124 | 536124 |
| | 2 | H2 | 533126 | 536126 |
| 4-40 NC | 2 | H1 | 533128 | 536128 |
| | 2 | H2* | 533130 | 536130 |
| | 2 | H6 | 533132 | 536132 |
| | 2 | H7 | 533134 | 536134 |
| 4-48 NF | 2 | H1 | 533136 | 536136 |
| | 2 | H2* | 533138 | 536138 |
| | 2 | H6 | 533140 | 536140 |
| | 2 | H7 | 533142 | 536142 |
| 4-36 NS | 2 | H1 | 533144 | 536144 |
| | 2 | H2* | 533146 | 536146 |
| 5-40 NC | 2 | H1 | 533148 | 536148 |
| | 2 | H2* | 533150 | 536150 |
| | 2 | H6 | 533152 | 536152 |
| | 2 | H7 | 533154 | 536154 |
| 5-44 NF | 2 | H1 | 533156 | 536156 |
| | 2 | H2* | 533158 | 536158 |
| | 2 | H6 | 533160 | 536160 |
| | 2 | H7 | 533162 | 536162 |
| 6-32 NC | 2 | H1 | 533164 | 536164 |
| | 2 | H2 | 533166 | 536166 |
| | 2 | H3* | 533168 | 536168 |
| | 2 | H6 | 533170 | 536170 |
| | 2 | H7 | 533172 | 536172 |

| Size | No. of Flutes | Pitch Diam. Limits | Bulk Product Number | |
|----------|---------------|--------------------|---------------------|--------|
| | | | Plug | Bottom |
| 6-40 NF | 2 | H1 | 533174 | 536174 |
| | 2 | H2* | 533176 | 536176 |
| | 2 | H6 | 533178 | 536178 |
| | 2 | H7 | 533180 | 536180 |
| 8-32 NC | 2 | H1 | 533182 | 536182 |
| | 2 | H2 | 533184 | 536184 |
| | 2 | H3* | 533186 | 536186 |
| | 2 | H6 | 533188 | 536188 |
| 8-36 NF | 2 | H1 | 533190 | 536190 |
| | 2 | H2* | 533192 | 536192 |
| | 2 | H3 | 533194 | 536194 |
| | 2 | H6 | 533196 | 536196 |
| | 2 | H7 | 533198 | 536198 |
| 10-24 NC | 2 | H1 | 533200 | 536200 |
| | 2 | H2 | 533206 | 536206 |
| | 2 | H3* | 533208 | 536208 |
| | 2 | H6 | 533210 | 536210 |
| 10-32 NF | 2 | H1 | 533212 | 536212 |
| | 2 | H7 | 533214 | 536214 |
| | 2 | H1 | 533216 | 536216 |
| | 2 | H2 | 533218 | 536218 |
| 12-24 NC | 2 | H3* | 533220 | 536220 |
| | 2 | H6 | 533222 | 536222 |
| | 2 | H7 | 533224 | 536224 |
| | 2 | H1 | 533226 | 536226 |
| 12-28 NF | 2 | H3* | 533228 | 536228 |
| | 2 | H1 | 533230 | 536230 |
| 14-20 NS | 2 | H1 | 533232 | 536232 |
| | 2 | H3 | 533234 | 536234 |
| 14-24 NS | 2 | H3 | 533235 | 536235 |

*Considered Standard



Features

- Individually packed
- Available in Plug and Bottom



| Size | No. of Flutes | Pitch Diam. Limits | Bulk Product Number | |
|------------|---------------|--------------------|---------------------|--------|
| | | | Plug | Bottom |
| 1/4-20 NC | 2 | H1 | 533236 | |
| | 2 | H2 | 533238 | |
| | 2 | H3* | 533240 | 536240 |
| | 2 | H5 | 533242 | |
| 1/4-20 NC | 3 | H1 | 533536 | |
| | 3 | H2 | 533538 | |
| | 3 | H3 | 533540 | 536540 |
| | 3 | H5 | 533542 | |
| 1/4-28 NF | 2 | H1 | 533244 | |
| | 2 | H2 | 533246 | |
| | 2 | H3* | 533248 | 536248 |
| | 2 | H4 | 533250 | |
| 1/4-28 NF | 3 | H1 | 533544 | |
| | 3 | H2 | 533546 | |
| | 3 | H3 | 533548 | 536548 |
| | 3 | H4 | 533550 | |
| 5/16-18 NC | 2 | H1 | 533252 | |
| | 2 | H2 | 533254 | |
| | 2 | H3* | 533256 | 536256 |
| | 2 | H5 | 533258 | |
| 5/16-18 NC | 3 | H1 | 533552 | |
| | 3 | H2 | 533554 | |
| | 3 | H3 | 533556 | 536556 |
| | 3 | H5 | 533558 | |
| 5/16-24 NF | 2 | H1 | 533260 | |
| | 2 | H2 | 533262 | |
| | 2 | H3* | 533264 | 536264 |
| | | H4 | 533266 | |
| 5/16-24 NF | 3 | H1 | 533560 | |
| | 3 | H2 | 533562 | |
| | 3 | H3 | 533564 | 536564 |
| | 3 | H4 | 533566 | |
| 3/8-16 NC | 3 | H1 | 533268 | 536268 |
| | 3 | H2 | 533270 | |
| | 3 | H3* | 533272 | 536272 |
| | 3 | H5 | 533274 | |
| 3/8-24 NF | 3 | H1 | 533276 | |
| | 3 | H2 | 533278 | |
| | 3 | H3* | 533280 | 536280 |
| | 3 | H4 | 533282 | |
| 7/16-14 NC | 3 | H1 | 533284 | |
| | 3 | H2 | 533286 | |
| | 3 | H3* | 533288 | 536288 |
| | 3 | H5 | 533290 | |

| Size | No. of Flutes | Pitch Diam. Limits | Bulk Product Number | |
|-------------|---------------|--------------------|---------------------|--------|
| | | | Plug | Bottom |
| 7/16-20 NF | 3 | H1 | 533292 | |
| | 3 | H2 | 522294 | |
| | 3 | H3* | 533296 | 536296 |
| | 3 | H5 | 533298 | |
| 1/2-13 NC | 3 | H1 | 533300 | |
| | 3 | H2 | 533302 | |
| | 3 | H3* | 533304 | 536304 |
| | 3 | H5 | 533306 | |
| 1/2-20 NF | 3 | H1 | 533308 | |
| | 3 | H2 | 533310 | |
| | 3 | H3* | 533312 | 536312 |
| | 3 | H5 | 533314 | |
| 9/16-12 NC | 3 | H1 | 533316 | |
| | 3 | H2 | 533318 | |
| | 3 | H3* | 533320 | 536320 |
| | 3 | H5 | 533322 | |
| 9/16-18 NF | 3 | H1 | 533324 | |
| | 3 | H2 | 533326 | |
| | 3 | H3* | 533328 | 536328 |
| | 3 | H5 | 533330 | |
| 5/8-11 NC | 3 | H1 | 533332 | |
| | 3 | H2 | 533334 | |
| | 3 | H3* | 533336 | 536336 |
| | 3 | H5 | 533338 | |
| 5/8-18 NF | 3 | H1 | 533340 | |
| | 3 | H2 | 533342 | |
| | 3 | H3* | 533344 | 536344 |
| | 3 | H5 | 533346 | |
| 11/16-11 NS | 3 | H3 | 533348 | 536348 |
| | 3 | H3 | 533350 | 536350 |
| 3/4-10 NC | 3 | H1 | 533352 | |
| | 3 | H2 | 533354 | |
| | 3 | H3* | 533356 | 536356 |
| | 3 | H5 | 533358 | |
| 3/4-16 NF | 3 | H1 | 533360 | |
| | 3 | H2 | 533362 | |
| | 3 | H3* | 533364 | 536364 |
| | 3 | H5 | 533366 | |

*Considered Standard

High Speed Steel Ground Thread Taps

Spiral Fluted · Machine Screw & Fractional Sizes

Features

- Individually packed
- Used to draw chips out of blind holes in ductile materials such as aluminum, brass, etc.



| Machine Size | No. of Flutes | Pitch Diam. Limits | Bulk Product Number | |
|--------------|---------------|--------------------|---------------------|--------|
| | | | Plug | Bottom |
| 4-40 NC | 2 | H2 | 543130 | 546130 |
| 4-48 NF | 2 | H2 | 543138 | 546138 |
| 5-40 NC | 2 | H2 | 543150 | 546150 |
| 5-44 NF | 2 | H2 | 543158 | 546158 |
| 6-32 NC | 2 | H3 | 543168 | 546168 |
| 6-40 NF | 2 | H2 | 543176 | 546176 |
| 8-32 NC | 2 | H3 | 543186 | 546186 |
| 8-36 NF | 2 | H2 | 543194 | 546194 |
| 10-24 NF | 2 | H3 | 543210 | 546210 |
| 10-32 NF | 2 | H3 | 543220 | 546220 |

| Fractional Size | No. of Flutes | Pitch Diam. Limits | Bulk Product Number | |
|-----------------|---------------|--------------------|---------------------|--------|
| | | | Plug | Bottom |
| 1/4-20 NC | 2 | H3 | 543240 | 546240 |
| | 3 | H3* | 543540 | 546540 |
| 1/4-28 NF | 2 | H3 | 543248 | 546248 |
| | 3 | H3* | 543548 | 546548 |
| 5/16-18 NC | 2 | H3 | 543256 | 546256 |
| | 3 | H3* | 543556 | 546556 |
| 5/16-24 NF | 2 | H3 | 543264 | 546264 |
| | 3 | H3* | 543564 | 546564 |
| 3/8-16 NC | 3 | H3 | 543272 | 546272 |
| 3/8-24 NF | 3 | H3 | 543280 | 546280 |
| 7/16-14 NC | 3 | H3 | 543288 | 546288 |
| 7/16-20 NF | 3 | H3 | 543296 | 546296 |
| 1/2-13 NC | 3 | H3 | 543304 | 546304 |
| 1/2-20 NF | 3 | H3 | 543312 | 546312 |

High Speed Steel Ground Thread Taps

Fast Spiral Fluted · Machine Screw & Fractional Sizes

Features

- Individually packed
- Used to draw chips out of blind holes in ductile materials such as aluminum, brass, etc.



| Machine Size | No. of Flutes | Pitch Diam. Limits | Bulk Product Number | |
|--------------|---------------|--------------------|---------------------|--------|
| | | | Plug | Bottom |
| 3-48 NC | 2 | H2 | 553122 | 556122 |
| 3-56 NF | 2 | H2 | 553126 | 556126 |
| 4-40 NC | 2 | H2 | 553130 | 556130 |
| 4-48 NF | 2 | H2 | 553138 | 556138 |
| 5-40 NC | 2 | H2 | 553150 | 556150 |
| 5-44 NF | 2 | H2 | 553158 | 556158 |
| 6-32 NC | 2 | H3 | 553168 | 556168 |
| 6-40 NF | 2 | H2 | 553176 | 556176 |
| 8-32 NC | 3 | H3 | 553186 | 556186 |
| 8-36 NF | 3 | H2 | 553194 | 556194 |
| 10-24 NF | 3 | H3 | 553210 | 556210 |
| 10-32 NF | 3 | H3 | 553220 | 556220 |
| 12-24 NC | 3 | H3 | 553228 | 556228 |
| 12-28 NF | 3 | H3 | 553232 | 556232 |

| Fractional Size | No. of Flutes | Pitch Diam. Limits | Bulk Product Number | |
|-----------------|---------------|--------------------|---------------------|--------|
| | | | Plug | Bottom |
| 1/4-20 NC | 3 | H3 | 553240 | 556240 |
| 1/4-28 NF | 3 | H3 | 553248 | 556248 |
| 5/16-18 NC | 3 | H3 | 553256 | 556256 |
| 5/16-24 NF | 3 | H3 | 553264 | 556264 |
| 3/8-16 NC | 3 | H3 | 553272 | 556272 |
| 3/8-24 NF | 3 | H3 | 553280 | 556280 |
| 7/16-14 NC | 3 | H3 | 553288 | 556288 |
| 7/16-20 NF | 3 | H3 | 553296 | 556296 |
| 1/2-13 NC | 3 | H3 | 553304 | 556304 |
| 1/2-20 NF | 3 | H3 | 553312 | 556312 |
| 9/16-12 NC | 4 | H3 | 553320 | 556320 |
| 9/16-18 NF | 4 | H3 | 553328 | 556328 |
| 5/8-11 NC | 4 | H3 | 553336 | 556336 |
| 5/8-18 NF | 4 | H3 | 553344 | 556344 |

*Considered Standard

Phone: (626) 291-5970



www.descotools.com

High Speed Steel Ground Thread Taps

Fluteless Spiral Point (Chip Driver) · Machine Screw Sizes

Features

- Individually packed
- Tap Wrenches available on page 73



| Size | No. of Flutes | Pitch Diam. Limits | Bulk Product Number Plug |
|---------|---------------|--------------------|--------------------------|
| 3-48 NC | 2 | H2 | 563122 |
| 3-56 NF | 2 | H2 | 563126 |
| 4-40 NC | 2 | H2* | 563130 |
| | 2 | H7 | 563134 |
| 4-48 NF | 2 | H2 | 563138 |
| 4-36 NS | 2 | H2* | 563146 |
| | 2 | H7 | 563148 |
| 5-40 NC | 2 | H2 | 563150 |
| 5-44 NF | 2 | H2 | 563158 |
| 6-32 NC | 2 | H2 | 563166 |
| | 2 | H3* | 563168 |
| | 2 | H7 | 563172 |

| Size | No. of Flutes | Pitch Diam. Limits | Bulk Product Number Plug |
|----------|---------------|--------------------|--------------------------|
| 6-40 NF | 2 | H2 | 563176 |
| 8-32 NC | 2 | H2 | 563184 |
| | 2 | H3* | 563186 |
| | 2 | H7 | 563190 |
| 8-36 NF | 2 | H2 | 563194 |
| 10-24 NC | 2 | H2 | 563208 |
| | 2 | H3* | 563210 |
| | 2 | H7 | 563214 |
| 10-32 NF | 2 | H3 | 563218 |
| | 2 | H3* | 563220 |
| 12-24 NC | 2 | H7 | 563224 |
| | 2 | H3 | 563228 |
| 12-28 NF | 2 | H3 | 563232 |

High Speed Steel Ground Thread Taps

Fluteless Spiral Point (Chip Driver) · Fractional Sizes

Features

- Individually packed
- Tap Wrenches available on page 73



| Size | No. of Flutes | Pitch Diam. Limits | Bulk Product Number Plug |
|------------|---------------|--------------------|--------------------------|
| 1/4-20 NC | 2 | H3 | 563240 |
| 1/4-28 NF | 2 | H3 | 563248 |
| 5/16-18 NC | 2 | H3 | 563256 |
| 5/16-24 NF | 2 | H3 | 563264 |
| 3/8-16 NC | 3 | H3 | 563272 |

| Size | No. of Flutes | Pitch Diam. Limits | Bulk Product Number Plug |
|------------|---------------|--------------------|--------------------------|
| 3/8-24 NF | 3 | H3 | 563280 |
| 7/16-14 NC | 3 | H3 | 563288 |
| 7/16-20 NF | 3 | H3 | 563296 |
| 1/2-13 NC | 3 | H3 | 563304 |
| 1/2-20 NF | 3 | H3 | 563312 |

*Considered Standard

High Speed Steel Ground Thread Taps

Pulley Taps · Fractional Sizes

Features

- Individually packed
- Tap Wrenches available on page 73



| Size | Overall Length | Thread | Bulk Product Number |
|------------|----------------|--------|---------------------|
| 1/4-20 NC | 6" | 1" | 573640 |
| | 8 | 1 | 573642 |
| 5/16-18 NC | 6 | 1-1/8 | 573656 |
| | 8 | 1-1/8 | 573658 |
| 3/8-16 NC | 6 | 1-1/4 | 573672 |
| | 8 | 1-1/4 | 573674 |
| | 10 | 1-1/4 | 573676 |
| 7/16-14 NC | 6 | 1-7/16 | 573688 |
| | 8 | 1-7/16 | 573690 |
| | 10 | 1-7/16 | 573692 |
| | 12 | 1-7/16 | 573694 |

| Size | Overall Length | Thread | Bulk Product Number | |
|-----------|----------------|----------|---------------------|--------|
| 1/2-13 NC | 6" | 1-21/32" | 573704 | |
| | 8 | 1-21/32 | 573706 | |
| | 10 | 1-21/32 | 573708 | |
| | 12 | 1-21/32 | 573710 | |
| | 5/8-11 NC | 6 | 1-13/16 | 573736 |
| | | 8 | 1-13/16 | 573738 |
| | 10 | 1-13/16 | 573740 | |
| | 12 | 1-13/16 | 573742 | |
| | 3/4-10 NC | 10 | 2 | 573756 |
| 12 | | 2 | 573758 | |

High Speed Steel Ground Thread Taps

Nut Taps · Fractional Sizes

Features

- Individually packed
- Tap Wrenches available on page 73



| Size | Overall Length | Thread | Pitch Diam. Limits | Bulk Product Number |
|------------|----------------|---------|--------------------|---------------------|
| 1/4-20 NC | 5" | 1-5/8" | H3 | 600240 |
| 1/4-28 NF | 5 | 1-1/4 | H3 | 600248 |
| 5/16-18 NC | 5-1/2 | 1-13/16 | H3 | 600256 |
| 5/16-24 NF | 5-1/2 | 1-3/8 | H3 | 600264 |
| 3/8-16 NC | 6 | 2 | H3 | 600272 |
| 3/8-24 NF | 6 | 1-1/2 | H3 | 600280 |
| 7/16-14 NC | 6-1/2 | 2-3/8 | H3 | 600288 |
| 7/16-20 NF | 6-1/2 | 1-3/4 | H3 | 600296 |
| 1/2-13 NC | 7 | 2-1/2 | H3 | 600304 |
| 1/2-20 NF | 7 | 1-7/8 | H3 | 600312 |

| Size | Overall Length | Thread | Pitch Diam. Limits | Bulk Product Number |
|-----------|----------------|--------|--------------------|---------------------|
| 5/8-11 NC | 8" | 3" | H3 | 600336 |
| 5/8-18 NF | 8 | 2-1/4 | H3 | 600334 |
| 3/4-10 NC | 9 | 3-1/4 | H3 | 600356 |
| 3/4-16 NF | 9 | 2-1/2 | H3 | 600364 |
| 7/8-9 NC | 10 | 3-5/8 | H4 | 600372 |
| 7/8-14 NF | 10 | 2-3/4 | H4 | 600380 |
| 1-8 NC | 11 | 4 | H4 | 600388 |
| 1-14 NS | 11 | 3-1/2 | H4 | 600396 |

*Considered Standard

High Speed Steel Ground Thread Taps

Taper Pipe Taps · Regular Thread

Features

- Individually packed
- Regular Thread



| Size | No. of Flutes | Bulk Product Number NPT or ANPT | NPTF |
|---------|---------------|------------------------------------|--------|
| 1/16-27 | 4 | 580800 | 581800 |
| 1/8-27 | 4 | 580802 | 581802 |
| 1/4-18 | 4 | 580804 | 581804 |
| 3/8-18 | 4 | 580806 | 581806 |
| 1/2-14 | 4 | 580808 | 581808 |

| Size | No. of Flutes | Bulk Product Number NPT or ANPT | NPTF |
|--------------|---------------|------------------------------------|--------|
| 3/4-14 | 5 | 580810 | 581810 |
| 1-11 1/2 | 5 | 580812 | 581812 |
| 1 1/4-11 1/2 | 5 | 580814 | 581814 |
| 1 1/2-11 1/2 | 7 | 580816 | 581816 |
| 2-11 1/2 | 7 | 580818 | 581818 |

High Speed Steel Ground Thread Taps

Taper Pipe Taps · For Cast Iron

Features

- Individually packed
- For Cast Iron



| Size | No. of Flutes | Bulk Product Number NPT or ANPT | NPTF |
|-------------------|---------------|------------------------------------|--------|
| 1/8-27 (Lg.Shk.)* | 4 | 590802 | 591802 |
| 1/8-27 (Sm.Shk.) | 4 | 590803 | 591803 |
| 1/4-18 | 4 | 590804 | 591804 |
| 3/8-18 | 4 | 590806 | 591806 |
| 1/2-14 | 4 | 590808 | 591808 |

| Size | No. of Flutes | Bulk Product Number NPT or ANPT | NPTF |
|--------------|---------------|------------------------------------|--------|
| 3/4-14 | 5 | 590810 | 591810 |
| 1-11 1/2 | 5 | 590812 | 591812 |
| 1 1/4-11 1/2 | 5 | 590814 | 591814 |
| 1 1/2-11 1/2 | 7 | 590816 | 591816 |
| 2-11 1/2 | 7 | 590818 | 591818 |

High Speed Steel Ground Thread Taps

Taper Pipe Taps · Interrupted Thread

Features

- Individually packed
- Interrupted Thread



| Size | No. of Flutes | Bulk Product Number NPT or ANPT | NPTF |
|--------|---------------|------------------------------------|--------|
| 1/8-27 | 5 | 585802 | 586802 |
| 1/4-18 | 5 | 585804 | 586804 |
| 3/8-18 | 5 | 585806 | 586806 |
| 1/2-14 | 5 | 585808 | 586808 |
| 3/4-14 | 5 | 585810 | 586810 |

| Size | No. of Flutes | Bulk Product Number NPT or ANPT | NPTF |
|--------------|---------------|------------------------------------|--------|
| 1-11 1/2 | 5 | 585812 | 586812 |
| 1 1/4-11 1/2 | 5 | 585814 | 586814 |
| 1 1/2-11 1/2 | 7 | 585816 | 586816 |
| 2-11 1/2 | 7 | 585818 | 586818 |

High Speed Steel Ground Thread Taps

Straight Pipe Taps · Fractional Sizes

Features

- Individually packed
- Tap Wrenches available on page 73



| Size | No. of Flutes | Bulk Product Number NPS | NPSF |
|-------------------|---------------|-------------------------|--------|
| 1/8-27 (Lg.Shk.)* | 4 | 595802 | 596802 |
| 1/8-27 (Sm.Shk.) | 4 | 595803 | 596803 |
| 1/4-18 | 4 | 595804 | 596804 |
| 3/8-18 | 4 | 595806 | 596806 |

| Size | No. of Flutes | Bulk Product Number NPS | NPSF |
|----------|---------------|-------------------------|--------|
| 1/2-14 | 4 | 595808 | 596808 |
| 3/4-14 | 5 | 595810 | 596810 |
| 1-11 1/2 | 5 | 595812 | 596812 |

High Speed Steel Ground Thread Taps

Left Hand Style · Machine Screw Sizes & Fractional Size

Features

- Individually packed
- Tap Wrenches available on page 73



| Size | No. of Flutes | Pitch Diam. Limits | Bulk Product Number Plug |
|------------|---------------|--------------------|--------------------------|
| 6-32 NC | 3 | H3 | 611500 |
| 6-40 NF | 3 | H3 | 611502 |
| 8-32 NC | 4 | H3 | 611504 |
| 8-36 NF | 4 | H3 | 611506 |
| 10-24 NC | 4 | H3 | 611508 |
| 10-32 NF | 4 | H3 | 611510 |
| 1/4-20 NC | 4 | H3 | 611512 |
| 1/4-28 NF | 4 | H3 | 611514 |
| 5/16-18 NC | 4 | H3 | 611516 |
| 5/16-24 NF | 4 | H3 | 611518 |
| 3/8-16 N | 4 | H3 | 611520 |
| 3/8-24 NF | 4 | H3 | 611522 |
| 7/16-14 NC | 4 | H3 | 611524 |
| 7/16-20 NF | 4 | H3 | 611526 |
| 1/2-13 NC | 4 | H3 | 611528 |
| 1/2-20 NF | 4 | H3 | 611530 |
| 9/16-12 NC | 4 | H3 | 611532 |
| 9/16-18 NF | 4 | H3 | 611534 |

| Size | No. of Flutes | Pitch Diam. Limits | Bulk Product Number Plug |
|-------------|---------------|--------------------|--------------------------|
| 5/8-11 NC | 4 | H3 | 611536 |
| 5/8-18 NF | 4 | H3 | 611538 |
| 3/4-10 NC | 4 | H3 | 611540 |
| 3/4-16 NF | 4 | H3 | 611542 |
| 7/8-9 NC | 4 | H4 | 611544 |
| 7/8-14 NF | 4 | H4 | 611546 |
| 1-8 NC | 4 | H4 | 611548 |
| 1-12 NF | 4 | H4 | 611550 |
| 1-14 NS | 4 | H4 | 611552 |
| 1 1/8-7 NC | 4 | H4 | 611554 |
| 1 1/8-12 NF | 4 | H4 | 611556 |
| 1 1/4-7 NC | 4 | H4 | 611558 |
| 1 1/4-12 NF | 6 | H4 | 611560 |
| 1 3/8-6 NC | 4 | H4 | 611562 |
| 1 3/8-12 NF | 6 | H4 | 611564 |
| 1 1/2-6 NC | 4 | H4 | 611566 |
| 1 1/2-12 NF | 6 | H4 | 611568 |

*Considered Standard

High Speed Steel Ground Thread Taps

Metric · ISO Recommended Sizes

Features

- Individually packed
- Available in Taper, Plug, and Bottom



| Size | No. of Flutes | Pitch Diam. Limits | Bulk Product Number | | |
|-----------|---------------|--------------------|---------------------|--------|--------|
| | | | Taper | Plug | Bottom |
| M1.5-0.35 | 2 | D2 | 620002 | 621002 | 622002 |
| M1.6-0.35 | 2 | D3 | 620004 | 621004 | 622004 |
| M1.8-0.35 | 2 | D3 | 620008 | 621008 | 622008 |
| M2-0.45 | 3 | D2 | 620014 | 621014 | 622014 |
| M2-0.4 | 3 | D3 | 620016 | 621016 | 622016 |
| M2.2-0.45 | 3 | D3 | 620022 | 621022 | 622022 |
| M2.3-0.4 | 3 | D2 | 620030 | 621030 | 622030 |
| M2.5-0.45 | 3 | D3 | 620032 | 621032 | 622032 |
| M2.6-0.45 | 3 | D2 | 620040 | 621040 | 622040 |
| M3-0.6 | 3 | D2 | 620044 | 621044 | 622044 |
| M3-0.5 | 3 | D3 | 620046 | 621046 | 622046 |
| M3.5-0.6 | 3 | D4 | 620052 | 621052 | 622052 |
| M4-0.75 | 4 | D3 | 620060 | 621060 | 622060 |
| M4-0.7 | 4 | D4 | 620062 | 621062 | 622062 |
| M4.5-0.75 | 4 | D4 | 620068 | 621068 | 622068 |
| M5-1 | 4 | D3 | 620076 | 621076 | 622076 |
| M5-0.9 | 4 | D3 | 620080 | 621080 | 622080 |
| M5-0.8 | 4 | D4 | 620082 | 621082 | 622082 |
| M5.5-0.9 | 4 | D3 | 620090 | 621090 | 622090 |
| M6-1 | 4 | D6 | 620092 | 621092 | 622092 |
| M6-0.75 | 4 | D3 | 620098 | 621098 | 622098 |
| M7-1 | 4 | D6 | 620100 | 621100 | 622100 |
| M7-0.75 | 4 | D4 | 620106 | 621106 | 622106 |
| M8-1.25 | 4 | D6 | 620108 | 621108 | 622108 |
| M8-1 | 4 | D6 | 620114 | 621114 | 622114 |
| M9-1.25 | 4 | D5 | 620118 | 621118 | 622118 |
| M9-1 | 4 | D6 | 620122 | 621122 | 622122 |
| M10-1.5 | 4 | D6 | 620124 | 621124 | 622124 |
| M10-1.25 | 4 | D6 | 620132 | 621132 | 622132 |
| M10-1 | 4 | D6 | 620136 | 621136 | 622136 |
| M11-1.5 | 4 | D6 | 620140 | 621140 | 622140 |
| M12-1.75 | 4 | D6 | 620142 | 621142 | 622142 |
| M12-1.5 | 4 | D6 | 620150 | 621150 | 622150 |
| M12-1.25 | 4 | D6 | 620154 | 621154 | 622154 |
| M14-2 | 4 | D6 | 620158 | 621158 | 622158 |
| M14-1.50 | 4 | D6 | 620164 | 621164 | 622164 |
| M14-1.25 | 4 | D6 | 620168 | 621168 | 622168 |
| M15-1.5 | 4 | D6 | 620172 | 621172 | 622172 |
| M16-2 | 4 | D6 | 620174 | 621174 | 622174 |
| M16-1.5 | 4 | D5 | 620182 | 621182 | 622182 |
| M17-1.5 | 4 | D6 | 620186 | 621186 | 622186 |
| M18-2.5 | 4 | D6 | 620188 | 621188 | 622188 |
| M18-2 | 4 | D6 | 620196 | 621196 | 622196 |
| M18-1.5 | 4 | D6 | 620200 | 621200 | 622200 |
| M19-2.5 | 4 | D4 | 620202 | 621202 | 622202 |
| | 4 | D6 | 620204 | 621204 | 622204 |
| M20-2.5 | 4 | D7 | 620206 | 621206 | 622206 |
| M20-2 | 4 | D4 | 620212 | 621212 | 622212 |
| | 4 | D6 | 620214 | 621214 | 622214 |
| M20-1.5 | 4 | D3 | 620216 | 621216 | 622216 |
| | 4 | D5 | 620218 | 621218 | 622218 |

| Size | No. of Flutes | Pitch Diam. Limits | Bulk Product Number | | |
|----------|---------------|--------------------|---------------------|--------|--------|
| | | | Taper | Plug | Bottom |
| M22-2.5 | 4 | D6 | 620222 | 621222 | 622222 |
| M22-2 | 4 | D4 | 620224 | 621224 | 622224 |
| | 4 | D6 | 620226 | 621226 | 622226 |
| M22-1.5 | 4 | D3 | 620228 | 621228 | 622228 |
| | 4 | D6 | 620230 | 621230 | 622230 |
| M24-3 | 4 | D8 | 620234 | 621234 | 622234 |
| M24-2 | 4 | D4 | 620236 | 621236 | 622236 |
| | 4 | D8 | 620238 | 621238 | 622238 |
| M24-1.50 | 4 | D3 | 620240 | 621240 | 622240 |
| | 4 | D5 | 620242 | 621242 | 622242 |
| M25-2 | 4 | D4 | 620244 | 621244 | 622244 |
| | 4 | D8 | 620246 | 621246 | 622246 |
| M25-1.5 | 4 | D3 | 620248 | 621248 | 622248 |
| | 4 | D5 | 620250 | 621250 | 622250 |
| M26-3 | 4 | D6 | 620252 | 621252 | 622252 |
| | 4 | D9 | 620254 | 621254 | 622254 |
| M27-3 | 4 | D9 | 620258 | 621258 | 622258 |
| M27-2 | 4 | D5 | 620260 | 621260 | 622260 |
| | 4 | D7 | 620262 | 621262 | 622262 |
| M28-3 | 4 | D5 | 620264 | 621264 | 622264 |
| | 4 | D9 | 620266 | 621266 | 622266 |
| M28-2 | 4 | D5 | 620268 | 621268 | 622268 |
| | 4 | D7 | 620270 | 621270 | 622270 |
| M30-3.5 | 4 | D9 | 620274 | 621274 | 622274 |
| M30-3 | 4 | D5 | 620276 | 621276 | 622276 |
| | 4 | D9 | 620278 | 621278 | 622278 |
| M30-2 | 4 | D5 | 620280 | 621280 | 622280 |
| | 4 | D7 | 620282 | 621282 | 622282 |
| M32-3.5 | 4 | D5 | 620284 | 621284 | 622284 |
| | 4 | D9 | 620286 | 621286 | 622286 |
| M32-2 | 6 | D5 | 620288 | 621288 | 622288 |
| | 6 | D7 | 620290 | 621290 | 622290 |
| M33-3.5 | 4 | D9 | 620294 | 621294 | 622294 |
| M33-3 | 4 | D5 | 620296 | 621296 | 622296 |
| | 4 | D9 | 620298 | 621298 | 622298 |
| M33-2 | 4 | D5 | 620300 | 621300 | 622300 |
| | 4 | D9 | 620302 | 621302 | 622302 |
| M34-3.5 | 4 | D5 | 620304 | 621304 | 622304 |
| | 4 | D9 | 620306 | 621306 | 622306 |
| M36-4 | 4 | D9 | 620310 | 621310 | 622310 |
| M36-3 | 4 | D5 | 620312 | 621312 | 622312 |
| | 4 | D9 | 620314 | 621314 | 622314 |
| M36-2 | 4 | D5 | 620316 | 621316 | 622316 |
| | 4 | D7 | 620318 | 621318 | 622318 |
| M38-4 | 4 | D5 | 620320 | 621320 | 622320 |
| | 4 | D9 | 620322 | 621322 | 622322 |
| M39-4 | 6 | D6 | 620324 | 621324 | 622324 |
| | 6 | D10 | 620326 | 621326 | 622326 |
| M39-3 | 6 | D6 | 620328 | 621328 | 622328 |
| | 6 | D8 | 620330 | 621330 | 622330 |
| M39-2 | 6 | D6 | 620332 | 621332 | 622332 |

High Speed Steel Ground Thread Taps

Spiral Point Metric Plug Taps

Features

- Individually packed
- Tap Wrenches available on page 73



| Size | No. of Flutes | Pitch Diam. Limits | Bulk Product Number |
|-----------|---------------|--------------------|---------------------|
| M1.6-0.35 | 2 | D3 | 623504 |
| M1.8-0.35 | 2 | D2 | 623508 |
| M2-0.4 | 2 | D3 | 623516 |
| M2.2-0.45 | 2 | D2 | 623522 |
| M2.5-0.45 | 2 | D3 | 623532 |
| M3-0.5 | 2 | D3 | 623546 |
| M3.5-0.6 | 2 | D4 | 623552 |
| M4-0.7 | 2 | D4 | 623562 |
| M4.5-0.75 | 2 | D4 | 623568 |
| M5-0.8 | 2 | D4 | 623582 |

| Size | No. of Flutes | Pitch Diam. Limits | Bulk Product Number |
|----------|---------------|--------------------|---------------------|
| M6-1 | 2 | D5 | 623592 |
| M7-1 | 2 | D5 | 623600 |
| M8-1.25 | 2 | D5 | 623608 |
| M10-1.5 | 3 | D6 | 623624 |
| M12-1.75 | 3 | D6 | 623642 |
| M14-2 | 3 | D7 | 623656 |
| M16-2 | 3 | D7 | 623674 |
| M18-2.5 | 3 | D7 | 623688 |
| M20-2.5 | 3 | D7 | 623706 |

High Speed Steel Combined Taps and Drills

Right Hand Style · Commercial Ground Tolerance · Machine Screw and Fractional Sizes

Features

- 1 per pack
- These combined drills and taps will do two operations at one time.



| Size | Overall Length | Thread Length | Drill Length | Drill Size | Product Number Bulk |
|----------|----------------|---------------|--------------|------------|---------------------|
| 4-40 NC | 1-7/8" | 9/16" | 1/4" | .089" | 26108 |
| 4-48 NF | 1-7/8 | 9/16 | 1/4 | .093 | 26110 |
| 5-40 NC | 1-15/16 | 5/8 | 9/32 | .1015 | 26111 |
| 5-44 NF | 1-15/16 | 5/8 | 9/32 | .104 | 26112 |
| 6-32 NC | 2 | 11/16 | 5/16 | .1095 | 26113 |
| 6-40 NF | 2 | 11/16 | 5/16 | .115 | 26114 |
| 8-32 NC | 2-1/8 | 3/4 | 3/8 | .136 | 26115 |
| 8-36 NF | 2-1/8 | 3/4 | 3/8 | .1385 | 26116 |
| 10-24 NC | 2-3/8 | 7/8 | 13/32 | .152 | 26118 |
| 10-32 NF | 2-3/8 | 7/8 | 13/32 | .161 | 26119 |
| 12-24 NC | 2-3/8 | 7/8 | 15/32 | .177 | 26120 |
| 12-28 NF | 2-3/8 | 7/8 | 15/32 | .1835 | 26121 |

| Size | Overall Length | Thread Length | Drill Length | Drill Size | Product Number Bulk |
|------------|----------------|---------------|--------------|------------|---------------------|
| 1/4-20 NC | 2-1/2" | 15/16 | 17/32 | .201 | 26130 |
| 1/4-28 NF | 2-1/2 | 15/16 | 17/32 | .2175 | 26131 |
| 5/16-18 NC | 3 | 1-1/8 | 11/16 | .257 | 26132 |
| 5/16-24 NF | 3 | 1-1/8 | 11/16 | .272 | 26133 |
| 3/8-16 NC | 3-1/2 | 1-1/4 | 13/16 | .3125 | 26134 |
| 3/8-24 NF | 3-1/2 | 1-1/4 | 13/16 | .3345 | 26135 |
| 7/16-14 NC | 3-7/8 | 1-7/16 | 1 | .368 | 26136 |
| 7/16-20 NF | 3-7/8 | 1-7/16 | 1 | .389 | 26137 |
| 1/2-13 NC | 4-1/4 | 1-21/32 | 1-1/8 | .425 | 26138 |
| 1/2-20 NF | 4-1/4 | 1-21/32 | 1-1/8 | .451 | 26139 |

Features

- Individually packed
- Tap Wrenches available on page 73



| Size | No. of Flutes | Overall Length | Drill Length | Drill Size | Thread Length | Diam. Shank | Square | Product Number Bulk |
|--------------|---------------|----------------|--------------|------------|---------------|-------------|--------|---------------------|
| 1/16-27 NPT | 4 | 2-13/16" | 11/16" | D | 11/16" | .312" | .234" | 26200 |
| 1/8-27 NPT | 4 | 2-7/8 | 3/4 | R | 3/4 | .437 | .328 | 26201 |
| 1/4-18 NPT | 4 | 3-5/16 | 7/8 | 7/16 | 1-1/16 | .562 | .421 | 26202 |
| 3/8-18 NPT | 4 | 3-1/2 | 15/16 | 37/64 | 1-1/16 | .700 | .531 | 26203 |
| 1/2-14 NPT | 4 | 4-3/8 | 1-1/4 | 45/64 | 1-3/8 | .687 | .515 | 26204 |
| 3/4-14 NPT | 5 | 4-9/16 | 1-5/16 | 59/64 | 1-3/8 | .906 | .679 | 26205 |
| 1-11 1/2 NPT | 5 | 5-3/8 | 1-5/8 | 1-5/32 | 1-3/4 | 1.125 | .843 | 26206 |



Tap and Die Sets available on page 68

*Considered Standard

Carbon Steel Round Dies

Solid and Screw Adjusting · Machine Screw · Right Hand and Left Hand

Features

- 5 per pack
- Available in Solid and Screw Adjusting
- Available in Left Hand



| Size | Solid | | Screw Adjusting | | | | | | |
|----------|------------|--------------|-----------------|------------|----------------|--------|------------|-----------------|---------------------|
| | 1" OD Bulk | 1" OD Carded | 13/16" OD Bulk | 1" OD Bulk | 1-1/2" OD Bulk | Carded | 2" OD Bulk | 1" OD Left Hand | 1-1/2" OD Left Hand |
| 0-80 NF | - | - | 11620 | - | - | - | - | - | - |
| 1-64 NC | - | - | 11622 | - | - | - | - | - | - |
| 1-72 NF | - | - | 11624 | - | - | - | - | - | - |
| 2-56 NC | - | - | 11626 | - | - | - | - | - | - |
| 2-64 NF | - | - | 11628 | - | - | - | - | - | - |
| 3-48 NC | - | - | 11630 | - | - | - | - | - | - |
| 3-56 NF | - | - | 11632 | - | - | - | - | - | - |
| 4-36 NS | 11420 | 17000 | 11634 | 11750 | - | - | - | 15620 | - |
| 4-40 NC | 11422 | 17002 | 11636 | 11752 | - | - | - | 15630 | - |
| 4-48 NF | - | - | 11638 | 11754 | - | - | - | - | - |
| 5-40 NC | 11426 | 17006 | 11641 | 11757 | - | - | - | - | - |
| 5-44 NF | - | - | 11643 | 11759 | - | - | - | - | - |
| 6-32 NC | 11428 | 17010 | 11645 | 11761 | - | - | - | 15632 | - |
| 6-36 NS | - | - | 11647 | 11763 | - | - | - | - | - |
| 6-40 NF | - | - | 11649 | 11765 | - | - | - | - | - |
| 6-48 NS | - | - | 11651 | 11767 | - | - | - | - | - |
| 8-32 NC | 11434 | 17016 | 11653 | 11770 | - | - | - | 15634 | - |
| 8-36 NF | - | - | 11655 | 11772 | - | - | - | - | - |
| 8-40 NS | - | - | 11657 | 11774 | - | - | - | - | - |
| 10-24 NC | 11438 | 17020 | 11659 | 11776 | - | - | - | 15636 | - |
| 10-32 NF | 11441 | 17024 | 11662 | 11779 | - | - | - | 15638 | - |
| 12-24 NC | 11442 | 17026 | 11664 | 11781 | - | - | - | 15640 | - |
| 12-28 NF | - | - | 11666 | 11783 | - | - | - | 15642 | - |
| 14-20 NS | 11445 | 17029 | 11670 | 11785 | - | - | - | 15644 | - |
| 14-24 NS | - | - | 11672 | - | - | - | - | - | - |

Solid and Screw Adjusting · Fractional · Right Hand and Left Hand

Features

- 5 per pack
- Available in Solid and Screw Adjusting
- Available in Left Hand



| Size | Solid | | Screw Adjusting | | | | | | |
|-------------|------------|--------------|-----------------|------------|----------------|--------|------------|-----------------|---------------------|
| | 1" OD Bulk | 1" OD Carded | 13/16" OD Bulk | 1" OD Bulk | 1-1/2" OD Bulk | Carded | 2" OD Bulk | 1" OD Left Hand | 1-1/2" OD Left Hand |
| 1/8-40 NS | - | - | 11700 | 11810 | - | - | - | - | - |
| 3/16-24 NS | 11460 | 17500 | 11702 | 11816 | - | - | - | - | - |
| 3/16-32 NSF | 11462 | - | 11704 | 11818 | - | - | - | - | - |
| 1/4-20 NC | 11470 | 17510 | 11716 | 11820 | 12000 | - | 12100 | 15650 | - |
| 1/4-24 NS | - | - | 11718 | 11822 | - | - | - | - | - |
| 1/4-28 NF | 11473 | 17513 | 11720 | 11824 | 12003 | - | 12104 | 15653 | - |
| 1/4-32 NEF | - | - | - | 11826 | - | - | - | - | - |
| 1/4-40 NS | - | - | 11722 | 11828 | - | - | - | - | - |
| 5/16-18 NC | 11477 | 17517 | 11724 | 11830 | 12007 | - | 12107 | 15657 | - |
| 5/16-24 NF | 11479 | 17519 | 11726 | 11832 | 12009 | - | 12109 | 15659 | - |
| 5/16-32 NEF | - | - | 11728 | 11834 | - | - | - | - | - |
| 3/8-16 NC | 11484 | 17524 | - | 11837 | 12014 | - | 12114 | 15664 | - |
| 3/8-24 NF | 11486 | 17526 | - | 11839 | 12016 | - | 12116 | 15666 | - |
| 7/16-14 NC | 11488 | 17529 | - | 11842 | 12019 | - | 12119 | 15669 | - |
| 7/16-20 NF | 11490 | 17531 | - | 11844 | 12021 | - | 12121 | 15672 | - |
| 1/2-13 NC | 11496 | 17535 | - | 11846 | 12024 | - | 12125 | 15674 | - |
| 1/2-20 NF | 11498 | 17537 | - | 11848 | 12026 | - | - | 15676 | 15720 |
| 1/2-24 NS | 11500 | - | - | 11850 | - | - | - | 15678 | 15724 |
| 9/16-12 NC | - | - | - | - | 12029 | 12080 | 12130 | - | 15726 |
| 9/16-18 NF | - | - | - | - | 12031 | 12082 | 12132 | - | 15728 |
| 5/8-11 NC | - | - | - | - | 12034 | 12084 | 12135 | - | 15731 |
| 5/8-18 NF | - | - | - | - | 12036 | 12086 | 12137 | - | 15734 |
| 11/16-11 NC | - | - | - | - | 12038 | - | 12139 | - | 15736 |
| 11/16-16 NF | - | - | - | - | 12040 | - | 12141 | - | 15738 |
| 3/4-10 NC | - | - | - | - | 12042 | 12088 | 12143 | - | - |
| 3/4-16 NF | - | - | - | - | 12044 | 12090 | 12145 | - | - |
| 7/8-9 NC | - | - | - | - | - | - | 12147 | - | - |
| 7/8-14 NF | - | - | - | - | - | - | 12149 | - | - |
| 1-8 NC | - | - | - | - | - | - | 12151 | - | - |
| 1-12 NF | - | - | - | - | - | - | 12153 | - | - |
| 1-14 NS | - | - | - | - | - | - | 12155 | - | - |
| 1/8-27 NPT | 11520 | 17800 | - | - | 12060 | - | - | - | - |
| 1/4-18 NPT | 11524 | 17810 | - | - | 12062 | - | - | - | - |
| 3/8-18 NPT | - | - | - | - | 12064 | 12096 | - | - | - |
| 1/2-14 NPT | - | - | - | - | 12066 | 12098 | 12160 | - | - |
| 3/4-14 NPT | - | - | - | - | - | - | 12162 | - | - |

High Speed Steel Round Dies

Screw Adjusting · Machine Screw Sizes

Features

- Individually Packed
- Die Stocks available on page 74



| Size | Bulk Product Number | |
|---------|---------------------|---------|
| | 13/16" O.D. | 1" O.D. |
| 0-80 NF | 701001 | - |
| 1-64 NC | 701002 | - |
| 1-72 NF | 701003 | - |
| 2-56 NC | 701004 | - |
| 2-64 NF | 701005 | - |
| 3-48 NC | 701006 | - |
| 3-56 NF | 701007 | - |

| Size | Bulk Product Number | |
|---------|---------------------|---------|
| | 13/16" O.D. | 1" O.D. |
| 4-36 NS | 701008 | 702008 |
| 4-40 NC | 701009 | 702009 |
| 4-48 NF | 701010 | 702010 |
| 5-40 NC | 701012 | 702012 |
| 5-44 NF | 701013 | 702013 |
| 6-32 NC | 701014 | 702014 |
| 6-40 NF | 701015 | 702015 |

| Size | Bulk Product Number | |
|----------|---------------------|---------|
| | 13/16" O.D. | 1" O.D. |
| 8-32 NC | 701018 | 702018 |
| 8-36 NF | 701019 | 702019 |
| 10-24 NC | 701021 | 702021 |
| 10-32 NF | 701022 | 702022 |
| 12-24 NC | 701024 | 702024 |
| 12-28 NF | 701025 | 702025 |
| 14-20 NS | 701026 | - |

High Speed Steel Round Dies

Screw Adjusting · Fractional Sizes

Features

- Individually Packed
- Die Stocks available on page 74



| Size | Bulk Product Number | | | |
|------------|---------------------|---------|-------------|---------|
| | 13/16" O.D. | 1" O.D. | 1-1/2" O.D. | 2" O.D. |
| 1/4-20 NC | 701038 | 702038 | 703038 | - |
| 1/4-28 NF | 701039 | 702039 | 703039 | - |
| 5/16-18 NC | 701041 | 702041 | 703041 | - |
| 5/16-24 NF | 701042 | 702042 | 703042 | - |
| 3/8-16 NC | - | 702044 | 703044 | - |
| 3/8-24 NF | - | 702045 | 703045 | - |
| 7/16-14 NC | - | 702046 | 703046 | - |
| 7/16-20 NF | - | 702047 | 703047 | - |
| 1/2-13 NC | - | 702048 | 703048 | - |
| 1/2-20 NF | - | 702049 | 703049 | - |

| Size | Bulk Product Number | | | |
|------------|---------------------|---------|-------------|---------|
| | 13/16" O.D. | 1" O.D. | 1-1/2" O.D. | 2" O.D. |
| 9/16-12 NC | - | - | 703051 | - |
| 9/16-18 NF | - | - | 703052 | - |
| 5/8-11 NC | - | - | 703053 | 704053 |
| 5/8-18 NF | - | - | 703054 | 704054 |
| 3/4-10 NC | - | - | 703057 | 704057 |
| 3/4-16 NF | - | - | 703058 | 704058 |
| 7/8-9 NC | - | - | - | 704059 |
| 7/8-14 NF | - | - | - | 704060 |
| 1-8 NC | - | - | - | 704061 |
| 1-12 NF | - | - | - | 704062 |
| 1-14 NS | - | - | - | 704063 |

High Speed Steel Round Dies

Screw Adjusting · ISO Metric Sizes

Features

- Individually Packed
- Die Stocks available on page 74



| Size | Bulk Product Number | | |
|-----------|---------------------|-------------|---------|
| | 1" O.D. | 1-1/2" O.D. | 2" O.D. |
| M1.6-0.35 | 706002 | - | - |
| M1.8-0.35 | 706004 | - | - |
| M2-0.4 | 706006 | - | - |
| M2.2-0.45 | 706008 | - | - |
| M2.5-0.45 | 706010 | - | - |
| M3-0.6 | 706012 | - | - |
| M3-0.5 | 706014 | - | - |
| M3.5-0.6 | 706016 | - | - |
| M4-0.75 | 706018 | - | - |
| M4-0.7 | 706020 | - | - |
| M4.5-0.75 | 706022 | - | - |
| M5-0.9 | 706024 | - | - |
| M5-0.8 | 706026 | - | - |
| M6-1 | 706028 | - | - |
| M6.3-1 | 706030 | - | - |
| M7-1 | 706032 | - | - |
| M8-1.25 | 706034 | - | - |
| M8-1 | 706036 | - | - |
| M9-0.75 | 706038 | - | - |

| Size | Bulk Product Number | | |
|----------|---------------------|-------------|---------|
| | 1" O.D. | 1-1/2" O.D. | 2" O.D. |
| M10-1.5 | 706040 | 707040 | - |
| M10-1.25 | 706042 | 707042 | - |
| M10-1 | 706044 | - | - |
| M11-1.5 | 706046 | - | - |
| M12-1.75 | 706048 | 707044 | - |
| M12-1.5 | 706050 | - | - |
| M12-1.25 | 706052 | 707046 | - |
| M14-2 | - | 707048 | - |
| M14-1.5 | - | 707050 | - |
| M16-2 | - | 707052 | - |
| M16-1.5 | - | 707054 | - |
| M18-2.5 | - | 707056 | - |
| M18-1.5 | - | 707058 | - |
| M20-2.5 | - | - | 708060 |
| M20-1.5 | - | - | 708062 |
| M22-2.5 | - | - | 708064 |
| M22-1.5 | - | - | 708066 |
| M24-3 | - | - | 708068 |
| M24-2 | - | - | 708070 |

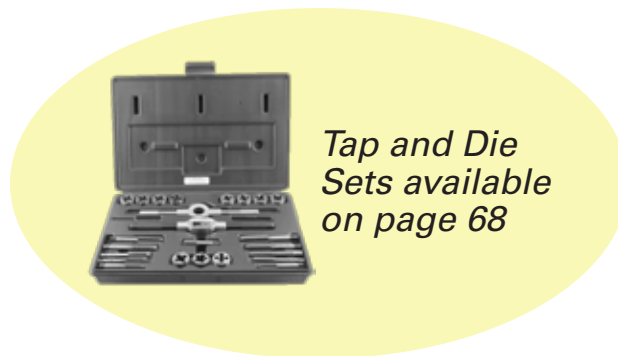

Tap and Die Sets available on page 68

Carbon Steel Hex Dies

Machine Screw

Features

- 5 per pack
- Available in Bulk and Carded
- Die Stocks available on page 74

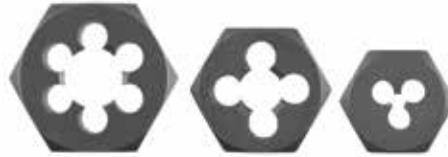

| Size | 1" (Across Flats) | |
|---------|-------------------|--------|
| | Bulk | Carded |
| 4-36 NS | 15068 | 18020 |
| 4-40 NC | 15072 | 18024 |
| 5-40 NC | 15076 | 18026 |
| 6-32 NC | 15080 | 18028 |
| 8-32 NC | 15086 | 18030 |

| Size | 1" (Across Flats) | |
|----------|-------------------|--------|
| | Bulk | Carded |
| 10-24 NC | 15090 | 18034 |
| 10-32 NF | 15093 | 18037 |
| 12-24 NC | 15095 | 18039 |
| 14-20 NS | 15097 | 18042 |

Carbon Steel Hex Dies

Fractional

Features

- 5 per pack
- Available in Bulk and Carded

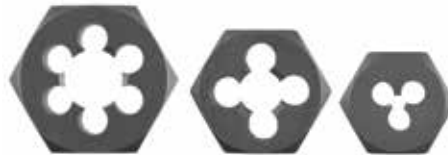

| Size | 1" (Across Flats) | | 1-7/16" (Across Flats) | | 1-7/8" (Across Flats) |
|------------|-------------------|--------|------------------------|--------|-----------------------|
| | Bulk | Carded | Bulk | Carded | Bulk |
| 1/4-20 NC | 15100 | 18100 | - | - | - |
| 1/4-28 NF | 15103 | 18104 | - | - | - |
| 5/16-18 NC | 15105 | 18108 | - | - | - |
| 5/16-24 NF | 15107 | 18110 | - | - | - |
| 3/8-16 NC | 15112 | 18116 | - | - | - |
| 3/8-24 NF | 15114 | 18118 | - | - | - |
| 7/16-14 NC | 15117 | 18122 | - | - | - |
| 7/16-20 NF | 15119 | 18124 | - | - | - |
| 1/2-13 NC | 15124 | 18128 | 15310 | 15340 | - |
| 1/2-20 NF | 15126 | 18130 | 15312 | 15342 | - |
| 9/16-12 NC | - | - | 15315 | 15344 | - |
| 9/16-18 NF | - | - | 15317 | 15346 | - |
| 5/8-11 NC | - | - | 15320 | 15348 | - |
| 5/8-18 NF | - | - | 15324 | 15350 | - |
| 3/4-10 NC | - | - | 15328 | 15352 | - |
| 3/4-16 NF | - | - | 15330 | 15354 | - |
| 7/8-9 NC | - | - | - | - | 16400 |
| 7/8-14 NF | - | - | - | - | 16402 |
| 1-8 NC | - | - | - | - | 16404 |
| 1-14 NS | - | - | - | - | 16406 |
| 1/8-27 NPT | 15300 | 18200 | 15400 | - | - |
| 1/4-18 NPT | 15302 | 18204 | 15402 | - | - |
| 3/8-18 NPT | - | - | 15404 | 15356 | - |
| 1/2-14 NPT | - | - | 15406 | 15358 | - |

← **Features** →

- 5 per pack
- Available in Bulk and Carded
- Die Stocks available on page 74

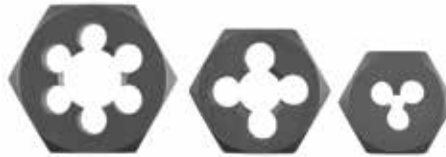

| Size | 1" (Across Flats) | | 1-7/16" (Across Flats) | | 1-7/8" (Across Flats) |
|-----------|-------------------|--------|------------------------|--------|-----------------------|
| | Bulk | Carded | Bulk | Carded | Bulk |
| M3-0.50 | 15198 | - | - | - | - |
| M3-0.60 | 15200 | 18250 | - | - | - |
| M4-0.70 | 15205 | 18254 | - | - | - |
| M4-0.75 | 15207 | 18258 | - | - | - |
| M5-0.80 | 15211 | 18262 | - | - | - |
| M5-0.90 | 15213 | 18266 | - | - | - |
| M6-1.00 | 15217 | 18270 | - | - | - |
| M6.3-1.00 | 15219 | - | - | - | - |
| M7-1.00 | 15221 | 18274 | - | - | - |
| M8-1.00 | 15223 | 18278 | - | - | - |
| M8-1.25 | 15225 | 18282 | - | - | - |
| M9-0.75 | 15227 | 18286 | - | - | - |
| M9-1.00 | 15229 | 18290 | - | - | - |
| M9-1.25 | 15231 | 18294 | - | - | - |
| M10-1.00 | 15233 | 18296 | - | - | - |
| M10-1.25 | 15235 | 18300 | - | - | - |
| M10-1.50 | 15237 | 18302 | - | - | - |
| M11-1.50 | 15239 | 18304 | - | - | - |
| M12-1.25 | 15241 | 18306 | - | - | - |
| M12-1.50 | 15243 | 18308 | - | - | - |
| M12-1.75 | 15245 | 18310 | - | - | - |
| M14-1.25 | - | - | 15360 | 18400 | - |
| M14-1.50 | - | - | 15362 | 18404 | - |
| M14-2.00 | - | - | 15364 | 18408 | - |
| M16-1.50 | - | - | 15367 | - | - |
| M16-2.00 | - | - | 15370 | - | - |
| M18-1.50 | - | - | 15373 | - | - |
| M18-2.50 | - | - | 15375 | - | - |
| M20-2.50 | - | - | - | - | 16450 |
| M22-1.50 | - | - | - | - | 16452 |
| M24-2.00 | - | - | - | - | 16455 |
| M24-3.00 | - | - | - | - | 16459 |

Carbon Steel Hex Rethreading Dies

Fractional Sizes · Right Hand and Left Hand

Features

- Individually Carded
- Available in Right and Left Hand

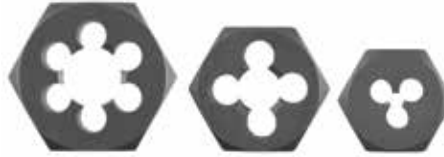

| Size | Width Across Flats | Thickness of Die | Bulk Product Number | | Size | Width Across Flats | Thickness of Die | Bulk Product Number | |
|-------------|--------------------|------------------|---------------------|-----------|-------------|--------------------|------------------|---------------------|-----------|
| | | | Right Hand | Left Hand | | | | Right Hand | Left Hand |
| 1/4-20 NC | 19/32" | 1/4" | 15420 | 15420L | 3/4-10 NC | 1-7/16" | 3/4" | 15458 | 15458L |
| 1/4-28 NF | 19/32 | 1/4 | 15423 | 15423L | 3/4-16 NF | 1-7/16 | 3/4 | 15460 | 15460L |
| 5/16-18 NC | 11/16 | 5/16 | 15427 | 15427L | 7/8-9 NC | 1-5/8 | 7/8 | 15461 | 15461L |
| 5/16-24 NF | 11/16 | 5/16 | 15429 | 15429L | 7/8-14 NF | 1-5/8 | 7/8 | 15463 | 15463L |
| 3/8-16 NC | 25/32 | 3/8 | 15434 | 15434L | 1-8 NC | 1-13/16 | 1 | 15465 | 15465L |
| 3/8-24 NF | 25/32 | 3/8 | 15436 | 15436L | 1-12 NF | 1-13/16 | 1 | 15466 | 15466L |
| 7/16-14 NC | 7/8 | 7/16 | 15439 | 15439L | 1-14 NS | 1-13/16 | 1 | 15467 | 15467L |
| 7/16-20 NF | 7/8 | 7/16 | 15440 | 15440L | 1 1/8-7 NC | 2 | 1 | 15468 | - |
| 1/2-13 NC | 1-1/16 | 1/2 | 15444 | 15444L | 1 1/8-12 NF | 2 | 1 | 15469 | - |
| 1/2-20 NF | 1-1/16 | 1/2 | 15445 | 15445L | 1 1/4-7 NC | 2-3/16 | 1 | 15470 | - |
| 9/16-12 NC | 1-1/16 | 1/2 | 15448 | 15448L | 1 1/4-12 NF | 2-3/16 | 1 | 15471 | - |
| 9/16-18 NF | 1-1/16 | 1/2 | 15449 | 15449L | 1 3/8-6 NC | 2-3/8 | 1 | 15472 | - |
| 5/8-11 NC | 1-1/4 | 5/8 | 15452 | 15452L | 1 3/8-12 NF | 2-3/8 | 1 | 15473 | - |
| 5/8-18 NF | 1-1/4 | 5/8 | 15454 | 15454L | 1 1/2-6 NC | 2-9/16 | 1 | 15474 | - |
| 11/16-11 NS | 1-7/16 | 3/4 | 15456 | 15456L | 1 1/2-12 NF | 2-9/16 | 1 | 15475 | - |
| 11/16-16 NS | 1-7/16 | 3/4 | 15457 | 15457L | | | | | |

Carbon Steel Hex Rethreading Dies

Metric Sizes · Right Hand and Left Hand

Features

- Individually Carded
- Available in Right and Left Hand



| Size | Width Across Flats | Thickness of Die | Bulk Product Number | | Size | Width Across Flats | Thickness of Die | Bulk Product Number | |
|----------|--------------------|------------------|---------------------|-----------|----------|--------------------|------------------|---------------------|-----------|
| | | | Right Hand | Left Hand | | | | Right Hand | Left Hand |
| M14-1.25 | 1-1/16" | 1/2" | 15550 | - | M20-1.50 | 1-7/16" | 3/4" | 15517 | - |
| M14-1.50 | 1-1/16 | 1/2 | 15502 | - | M20-2.50 | 1-7/16 | 3/4 | 15518 | - |
| M14-2.00 | 1-1/16 | 1/2 | 15504 | - | M22-1.50 | 1-5/8 | 7/8 | 15521 | 15815 |
| M16-1.50 | 1-1/4 | 5/8 | 15507 | 15800 | M24-1.50 | 1-13/16 | 1 | 15523 | - |
| M16-2.00 | 1-1/4 | 5/8 | 15509 | - | M24-2.00 | 1-13/16 | 1 | 15525 | - |
| M18-1.00 | 1-7/16 | 3/4 | 15511 | 15805 | M24-3.00 | 1-13/16 | 1 | 15527 | - |
| M18-1.50 | 1-7/16 | 3/4 | 15513 | 15807 | M30-1.50 | 2 | 1 | 15535 | - |
| M18-2.50 | 1-7/16 | 3/4 | 15515 | - | | | | | |

Carbon Steel Hex Rethreading Dies

NPT Pipe Sizes · Hex Rethreading Dies

Features

- Individually Carded
- Die Stocks available on page 74

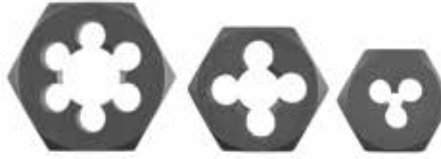

| Size | Width Across Flats | Thickness of Die | Product Number Bulk |
|------------|--------------------|------------------|---------------------|
| 1/8-27 NPT | 1-1/16" | 3/8" | 15600 |
| 1/4-18 NPT | 1-1/4 | 5/8 | 15602 |
| 3/8-18 NPT | 1-7/16 | 5/8 | 15604 |
| 1/2-14 NPT | 1-5/8 | 3/4 | 15606 |
| 3/4-14 NPT | 2 | 13/16 | 15608 |

| Size | Width Across Flats | Thickness of Die | Product Number Bulk |
|------------------|--------------------|------------------|---------------------|
| 1-11 1/2 NPT | 2-3/8 | 1 | 15610 |
| 1 1/4-11 1/2 NPT | 2-3/4 | 1 | 15612 |
| 1 1/2-11 1/2 NPT | 3 | 1 | 15614 |
| 2-11 1/2 NPT | 4 | 1 | 15616 |



Tap and Die Sets available on page 68



Wrenches and Die Stocks Available on page 73

Tap Sets

3 Piece Tap Set

- Available in Machine Screw, Fractional, or Metric
- In Vinyl Pouch
- One each Taper, Plug and Bottom



Machine Screw Sets

| Size | Bulk Product Number | Size | Bulk Product Number | Size | Bulk Product Number |
|---------|---------------------|---------|---------------------|-----------|---------------------|
| 0-80 NF | 11250 | 4-48 NF | 11268 | 8-40 NS | 11287 |
| 1-64 NC | 11252 | 5-40 NC | 11270 | 10-24 NC | 11289 |
| 1-72 NF | 11254 | 5-44 NF | 11272 | 10-32 NF | 11293 |
| 2-56 NC | 11256 | 6-32 NC | 11274 | 12-24 NC | 11295 |
| 2-64 NF | 11258 | 6-36 NS | 11276 | 12-28 NF | 11297 |
| 3-48 NC | 11260 | 6-40 NF | 11278 | 12-32 NEF | 11299 |
| 3-56 NF | 11262 | 6-48 NS | 11280 | 14-20 NS | 11305 |
| 4-36 NS | 11264 | 8-32 NC | 11283 | 14-24 NS | 11307 |
| 4-40 NC | 11266 | 8-36 NF | 11285 | | |

Fractional Sets

| Size | Bulk Product Number | Size | Bulk Product Number | Size | Bulk Product Number |
|-------------|---------------------|------------|---------------------|-------------|---------------------|
| 1/8-40 NS | 11319 | 3/8-16 NC | 11345 | 5/8-18 NF | 11368 |
| 3/16-24 NS | 11325 | 3/8-24 NF | 11347 | 11/16-11 NS | 11370 |
| 3/16-32 NS | 11327 | 7/16-14 NC | 11350 | 11-16-16 NS | 11372 |
| 1/4-20 NC | 11329 | 7/16-20 NF | 11352 | 3/4-10 NC | 11374 |
| 1/4-24 NS | 11331 | 1/2-13 NC | 11356 | 3/4-16 NF | 11376 |
| 1/4-28 NF | 11333 | 1/2-20 NF | 11358 | 7/8-9 NC | 11378 |
| 1/4-32 NEF | 11335 | 1/2-24 NS | 11360 | 7/8-14 NF | 11380 |
| 1/4-40 NS | 11337 | 9/16-12 NC | 11362 | 1-8 NC | 11382 |
| 5/16-18 NC | 11339 | 9/16-18 NF | 11364 | 1-12 NF | 11384 |
| 5/16-24 NF | 11341 | 5/8-11 NC | 11366 | 1-14 NS | 11386 |
| 5/16-32 NEF | 11343 | | | | |

Metric Sets

| Size | Bulk Product Number | Size | Bulk Product Number | Size | Bulk Product Number |
|-----------|---------------------|----------|---------------------|----------|---------------------|
| M3-0.50 | 11148 | M8-1.25 | 11168 | M14-1.50 | 11192 |
| M3-0.60 | 11150 | M9-0.75 | 11170 | M14-2.00 | 11194 |
| M3.5-0.60 | 11151 | M9-1.00 | 11172 | M16-1.50 | 11196 |
| M4-0.70 | 11152 | M9-1.25 | 11174 | M16-2.00 | 11198 |
| M4-0.75 | 11154 | M10-1.00 | 11176 | M18-1.50 | 11200 |
| M4.5-0.75 | 11155 | M10-1.25 | 11178 | M18-2.50 | 11202 |
| M5-0.80 | 11156 | M10-1.50 | 11180 | M20-1.50 | 11203 |
| M5-0.90 | 11158 | M11-1.50 | 11182 | M20-2.50 | 11204 |
| M6-1.00 | 11160 | M12-1.25 | 11184 | M22-1.50 | 11206 |
| M6.3-1.00 | 11162 | M12-1.50 | 11186 | M22-2.50 | 11207 |
| M7-1.00 | 11164 | M12-1.75 | 11188 | M24-2.00 | 11208 |
| M8-1.00 | 11166 | M14-1.25 | 11190 | M24-3.00 | 11210 |



12 Piece Tap and Die Set

- Sizes: 1/4"-1/2" NC
- Plug Taps with Round or Hex Dies
- Carbon Steel

In Sturdy Plastic Case.

NC Sizes 1/4" through 1/2" in plastic case with 5 taps and 5 dies plus 1 die stock (#44244) and 1 tap wrench (#44188).

Sizes: 1/4-20 NC, 5/16-18 NC, 3/8-16 NC, 7/16-14 NC, and 1/2-13 NC.

| Description | Product Number |
|---|----------------|
| Carbon steel set with 1" Round Solid Dies | 44310 |
| Carbon steel set with 1" Hex Solid Dies | 44316 |



12 Piece Tap and Die Set

- Sizes: 1/4"-1/2" NF
- Plug Taps with Round or Hex Dies
- Carbon Steel

In Sturdy Plastic Case.

NF Sizes 1/4" though 1/2" in plastic case with 5 taps and 5 dies plus 1 die stock (#44244) and 1 tap wrench (#44188).

Sizes: 1/4-28 NF, 5/16-24 NF, 3/8-24 NF, 7/16-20 NF, and 1/2-20 NF.

| Description | Product Number |
|---|----------------|
| Carbon steel set with 1" Round Solid Dies | 44312 |
| Carbon steel set with 1" Hex Solid Dies | 44318 |



24 Piece Tap and Die Set

- Sizes: 1/4"-1/2" NC and NF Sizes
- Plug Taps with Round or Hex Dies
- Carbon Steel or High Speed Steel

In Sturdy Plastic Case

NC and NF Sizes 1/4" though 1/2" in plastic case with 11 taps and 11 dies plus 1 die stock (#44250) and 1 tap wrench (#44182).

Sizes: 1/4-20 NC, 1/4-28 NF, 5/16-18 NC, 5/16-24 NF, 3/8-16 NC, 3/8-24 NF, 7/16-14 NC, 7/16-20 NF, 1/2-13 NC, 1/2-20 NF, and 1/8-27 NPT.

| Description | Product Number |
|---|----------------|
| Carbon steel set with 1" Round Solid Dies | 44320 |
| Carbon steel set with 1" Hex Solid Dies | 44322 |
| Carbon steel set with 1" Round Screw Adjusting Dies | 44324 |
| High speed steel set with 1" Round Screw Adjusting Dies | 44326 |



Tap and Die Sets

40 Piece Tap and Die Set

- Sizes: 4"-1/2" NC and NF Sizes
- Plug Taps with 1" Round Dies
- Carbon Steel or High Speed Steel

NC and NF Sizes #4 through 1/2" in plastic case with 17 taps and 17 dies plus 1 die stock (#44250), 1 tap wrench (#44182), 2 each T-handle tap wrenches (#44190 and #44198), plus 1 screw pitch gauge (#51050) and 1 screwdriver (#51060).

Sizes: 4-40 NC, 6-32 NC, 8-32 NC, 10-24 NC, 10-32 NF, 12-24 NC, 1/4-20 NC, 1/4-28 NF, 5/16-18NC, 5/16-24 NF, 3/8-16 NC, 3/8-24 NF, 7/16-14 NC, 7/16-20 NF, 1/2-13 NC, 1/2-20 NF, and 1/8-27 NPT.



| Description | Product Number |
|---|----------------|
| Carbon steel set with 1" Round Solid Dies | 44330 |
| Carbon steel set with 1" Round Screw Adjusting Dies | 44332 |
| High speed steel set with 1" Round Screw Adjusting Dies | 44334 |

Tap and Die Sets

40 Piece Tap and Die Set

- Sizes: 4"-1/2" NC and NF Sizes
- Plug Taps with 1" Hexagon Dies
- Carbon Steel

NC and NF Sizes #4 through 1/2" in plastic case with 17 taps and 17 dies plus 1 die stock (#44250), 1 tap wrench (#44182), 2 each T-handle tap wrenches (#44190 and #44198), plus 1 screw pitch gauge (#51050) and 1 screwdriver (#51060).

Sizes: 4-40 NC, 6-32 NC, 8-32 NC, 10-24 NC, 10-32 NF, 12-24 NC, 1/4-20 NC, 1/4-28 NF, 5/16-18NC, 5/16-24 NF, 3/8-16 NC, 3/8-24 NF, 7/16-14 NC, 7/16-20 NF, 1/2-13 NC, 1/2-20 NF, and 1/8-27 NPT.



| Description | Product Number |
|---|----------------|
| Carbon steel set with 1" Hex solid dies | 44336 |

58 Piece Tap and Die Set

- Sizes: 6"-3/4" NC and NF Sizes
- Plug Taps with Hexagon Dies
- Carbon Steel

NC and NF Sizes #6 though 3/4" in plastic case with 23 taps and 23 dies plus 2 die stocks (#44256), 3 tap wrenches (#44182, #44184 & #44190) plus 1 screw pitch gauge (#51050), 1 screwdriver (#51060), and Nos. 1-5 screw extractors.

Sizes: 6-32 NC, 8-32 NC, 10-24 NC, 10-32 NF, 12-24 NC, 1/4-20 NC, 1/4-28 NF, 5/16-18 NC, 5/16-24 NF, 3/8-16 NC, 3/8-24 NF, 7/16-14 NC, 7/16-20 NF, 1/2-13 NC, 1/2-20 NF, 3/8-16 NC, 3/8-24 NF, 9/16-12 NC, 9/16-18 NF, 5/8-11 NC, 5/8-18 NF, 3/4-10 NC, 3/4-16 NF, 1/8-27 NPT, 1/4-18 NPT.



| Description | Product Number |
|--------------------------------|----------------|
| Carbon steel set with hex dies | 44340 |

65 Piece Tap and Die Set

- Sizes: 4"-1" NC and NF Sizes
- Plug Taps with Hex Dies
- Carbon Steel

NC and NF Sizes #4 though 1" in plastic case with 28 taps and 28 dies plus 3 die stocks (#44256, #44250), 4 tap wrenches (#44182, #44184, #44186, #44190) plus 1 screw pitch gauge (#51050), 1 screwdriver (#51060), and Nos. 1-5 screw extractors.

Sizes: 4-40 NC, 6-32 NC, 8-32 NC, 10-24 NC, 10-32 NF, 12-24 NC, 1/4-20 NC, 1/4-28 NF, 5/16-18 NC, 5/16-24 NF, 3/8-16 NC, 3/8-24 NF, 7/16-14 NC, 7/16-20 NF, 1/2-13 NC, 1/2-20 NF, 3/8-16 NC, 3/8-24 NF, 9/16-12 NC, 9/16-18 NF, 5/8-11 NC, 5/8-18 NF, 3/4-10 NC, 3/4-16 NF, 7/8-9 NC, 7/8-14 NF, 1-8 NC, 1-12 NF, 1/8-27 NPT, 1/4-18 NPT.



| Description | Product Number |
|--------------------------------|----------------|
| Carbon steel set with Hex Dies | 44348 |

Tap and Die Sets

24 Piece Metric Tap and Die Set

- Sizes: M3-M12
- Plug Taps with Hex Dies
- Carbon Steel

Metric sizes M3 - M12 in plastic case with 10 taps and 10 dies plus 1 die stock (#44250), 1 tap wrench (#44182).

Sizes: M3-0.60, M4-0.70, M5-0.80, M6-1.00, M7-1.00, M8-1.25, M9-1.25, M10-1.50, M12-1.50, M12-1.75

| Description | Product Number |
|--------------------------------|----------------|
| Carbon steel set with Hex Dies | 44360 |



Tap and Die Sets

40 Piece Metric Tap and Die Set

- Sizes: M3-M12
- Plug Taps with Hex Dies
- Carbon Steel

Metric sizes M3 - M12 in plastic case with 17 taps and 17 dies plus 1 die stock (#44250), 3 tap wrenches (#44182, #44190, #44198) plus 1 screw pitch gauge (#51055) and 1 screwdriver (#51060).

Sizes: M3-0.50, M3-0.60, M4-0.70, M4-0.75, M5-0.80, M5-0.90, M6-1.00, M7-1.00, M8-1.25, M9-1.00, M9-1.25, M10-1.25, M10-1.50, M11-1.50, M12-1.50, M12-1.75.

| Description | Product Number |
|--------------------------------|----------------|
| Carbon steel set with Hex Dies | 44362 |



Tap and Die Sets

58 Piece Metric Tap and Die Set

- Sizes: M3-M18
- Plug Taps with Hex Dies
- Carbon Steel

Metric sizes M3 - M18 in plastic case with 23 taps and 23 dies plus 2 die stocks (#44250, #44256), 3 tap wrenches (#44182, #44184, #44190) plus 1 screw pitch gauge (#51055), 1 screwdriver (#51060), and Nos. 1 - 5 screw extractors.

Sizes: M3-0.60, M4-0.70, M4-0.75, M5-0.80, M5-0.90, M6-1.00, M7-1.00, M8-1.25, M9-1.00, M9-1.25, M10-1.25, M10-1.50, M11-1.50, M12-1.50, M12-1.75, M14-1.25, M14-2.00, M16-1.50, M16-2.00, M18-1.50, M18-2.50, 1/8-28 BSP, 1/4-19 BSP.

| Description | Product Number |
|--------------------------------|----------------|
| Carbon steel set with Hex Dies | 44364 |



6 Piece Pipe Tap Set

- Sizes: 1/8"-1" NPT Taper Pipe Sizes
- Carbon Steel or High Speed Steel
- Wood Case

Sizes: 1/8-27NPT, 1/4-18 NPT, 3/8-18 NPT, 1/2-14 NPT, 3/4-14 NPT, 1-11 1/2 NPT.

| Description | Product Number |
|----------------------|----------------|
| Carbon Steel Set | 10942 |
| High Speed Steel Set | 10943 |



6 Piece Hex Rethreading Die Set

- Sizes: 1/8"-1" NPT Taper Pipe Sizes
- Carbon Steel or High Speed Steel
- Wood Case

Sizes: 1/8-27NPT, 1/4-18 NPT, 3/8-18 NPT, 1/2-14 NPT, 3/4-14 NPT, 1-11 1/2 NPT.

| Description | Product Number |
|------------------|----------------|
| Carbon Steel Set | 10944 |

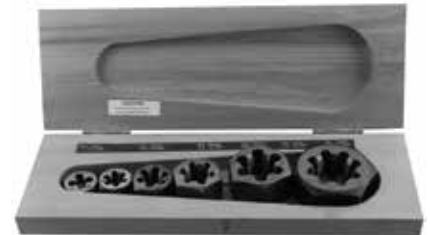

12 Piece Pipe Tap and Hex Rethreading Die Set

- Sizes: 1/8"-1" NPT Taper Pipe Sizes
- Carbon Steel • Wood Case

Sizes: 1/8-27NPT, 1/4-18 NPT, 3/8-18 NPT, 1/2-14 NPT, 3/4-14 NPT, 1-11 1/2 NPT.

| Description | Product Number |
|------------------|----------------|
| Carbon Steel Set | 10940 |



Tap Wrenches and Die Stocks

Adjustable Handle Tap and Reamer Wrenches

Features

- Individually Packed
- Bulk or Carded



Standard Duty

| Product Number | Description |
|----------------|---|
| 44182 | #4-1/2" plus 1/8"-1/4" pipe taps |
| 44183 | #4-1/2" plus 1/8"-1/4" pipe taps (Carded for display) |
| 44184 | 1/4" to 3/4" plus 1/8"-3/8" pipe taps |
| 44186 | 1/2"-1 1/8" plus 1/8"-3/4" pipe taps |

Heavy Duty

| Product Number | Description |
|----------------|---|
| 44170 | #4-1/4" taps |
| 44174 | 3/16"-1/2" taps plus 1/8"-1/4" pipe taps |
| 44176 | 1/4"-3/4" taps plus 1/8"-3/8" pipe taps |
| 44178 | 3/8"-1" taps plus 1/8"-3/4" pipe taps |
| 44179 | 5/8"-1 1/4" taps plus 1/4"-1 1/8" pipe taps |
| 44180 | 3/4"-1 1/2" taps plus 3/8"-1 1/4" pipe taps |
| 44181 | 1"-2 3/4" taps plus 1"-2 1/2" pipe taps |

Tap Wrenches and Die Stocks

Offset Handle Tap and Reamer Wrenches

| Product Number | Description |
|----------------|---|
| 44188 | #4-1/2" taps plus 1/8"-1/4" pipe taps |
| 44189 | #4-1/2" taps plus 1/8" to 1/4" pipe taps (Carded for display) |



Tap Wrenches and Die Stocks

Sliding T-Handle Tap Wrenches

Standard Duty

| Product Number | Description |
|----------------|--|
| 44190 | #0-1/4" taps |
| 44192 | #0-1/4" taps-CARDED |
| 44194 | #12-5/16" taps |
| 44196 | #12-5/16" taps-CARDED |
| 44198 | 1/4"-1/2" taps |
| 44200 | 1/4"-1/2" taps-CARDED |
| 44222 | 1/4"-1/2" taps (With 3/8" Square Drive and 7/8" Hex Nut) |
| 44223 | 1/4"-1/2" taps-CARDED |



Heavy Duty

| Product Number | Description |
|----------------|---------------|
| 44202 | #0-#8 taps |
| 44204 | #0-1/4" taps |
| 44206 | #12-1/2" taps |

Ratchet

| Product Number | Description |
|----------------|---------------|
| 44212 | #0-#8 taps |
| 44214 | #0-1/4" taps |
| 44218 | #12-1/2" taps |

Tap Wrenches and Die Stocks

3 Jaw Adjustable Die Stocks for Hex Dies

Features

- Three jaw adjustable guide helps maintain alignment for more accurate threading.

| Product Number | Description |
|----------------|------------------------|
| 44250 | 1" hexagon dies |
| 44252 | 1" hexagon dies-CARDED |
| 44254 | 1-7/16" hexagon dies |
| 44256 | 1-7/8" hexagon dies |



Tap Wrenches and Die Stocks

Plain Die Stocks for Hex Dies

Features

- Plain type
- Individually Packed
- Bulk or Carded

| Product Number | Description |
|----------------|------------------------|
| 44244 | 1" hexagon dies |
| 44246 | 1" hexagon dies-CARDED |
| 44248 | 1-7/16" hexagon dies |
| 44249 | 1-7/8" hexagon dies |



Tap Wrenches and Die Stocks

3 Jaw Adjustable Die Stocks for Round Dies

Features

- Three jaw adjustable guide helps maintain alignment for more accurate threading.

| Product Number | Description |
|----------------|-------------------------------|
| 44236 | 1" round solid dies |
| 44238 | 1" round solid dies-CARDED |
| 44240 | 1" round dies, screw adj. |
| 44242 | 1-1/2" round dies, screw adj. |
| 44243 | 2" round dies, screw adj. |



Tap Wrenches and Die Stocks

Plain Die Stocks for Round Dies

Features

- Plain type
- Individually Packed
- Bulk or Carded

| Product Number | Description |
|----------------|------------------------------------|
| 44224 | 13/16" round dies, screw adj. |
| 44226 | 1" round solid dies |
| 44228 | 1" round solid dies-CARDED |
| 44230 | 1" round dies, screw Adj. |
| 44232 | 1-1/2" round dies, screw adjusting |
| 44234 | 2" round dies, screw adj. |



Reamers and Countersinks

Countersinks · Single 82° Flute

← **Features** →

- Individually Packed



| Cutting Diameter | Overall Length | Shank Diameter | Shank Length | Product Number Bulk |
|------------------|----------------|----------------|--------------|---------------------|
| 1/4" | 1-1/2" | 3/16" | 3/4" | 47050 |
| 3/8 | 1-3/4 | 1/4 | 7/8 | 47052 |
| 1/2 | 2 | 3/8 | 1 | 47054 |
| 5/8 | 2-1/4 | 3/8 | 1 | 47056 |
| 3/4 | 2-5/8 | 1/2 | 1-1/4 | 47058 |
| 1 | 3-1/2 | 1/2 | 1-1/2 | 47060 |

Reamers and Countersinks

Center Reamers · Three 82° Flutes

← **Features** →

- Individually Packed



| Cutting Diameter | Overall Length | Shank Diameter | Shank Length | Product Number Bulk |
|------------------|----------------|----------------|--------------|---------------------|
| 1/4" | 1-1/2" | 3/16" | 3/4" | 47076 |
| 3/8 | 1-3/4 | 1/4 | 7/8 | 47078 |
| 1/2 | 2 | 3/8 | 1 | 47080 |
| 5/8 | 2-1/4 | 3/8 | 1 | 47082 |
| 3/4 | 2-5/8 | 1/2 | 1-1/4 | 47084 |
| 1 | 3 | 1/2 | 1-1/2 | 47086 |

Reamers and Countersinks

Countersinks · Five 82° Flutes

← **Features** →

- Individually Packed



| Cutting Diameter | Overall Length | Shank Diameter | Shank Length | Product Number Bulk |
|------------------|----------------|----------------|--------------|---------------------|
| 1/2" | 2-3/8" | 1/4" | 1" | 47103 |
| 5/8 | 2-1/2 | 1/4 | 1 | 47104 |
| 3/4 | 2-1/2 | 1/4 | 1 | 47105 |

Reamers and Countersinks

T-Handle Repairman's Reamers

Features

- Hardened and ground steel for removing burrs or enlarging holes in sheet, plastics and similar materials



| Description | Product Number |
|--|----------------|
| Repairman's Reamer 1/8" to 1/2" | 44268 |
| Repairman's Reamer 1/8" to 1/2" Carded | 44270 |
| Repairman's Reamer 1/2" to 1" | 44274 |
| Repairman's Reamer 1/2" to 1" Carded | 44276 |

Reamers and Countersinks

Repairman's Reamer

Features

- Plastic handle reamer for removing burrs, enlarging small holes in mild steels, wood, plastics, etc.
- Carded



| Description | Product Number |
|--|----------------|
| Repairman's Reamer with Plastic Handle 1/8" to 3/8" capacity | 44275 |

Reamers and Countersinks

Burring Reamer with 1/2" Round Shank

Features

- For removing burrs from pipe, conduit, etc., and enlarging holes in metals, plastics and other materials. Boxed.



| Description | Product Number |
|---|----------------|
| 1/2" Round Shank, Capacity 1/4" to 1-1/4" | 44290 |
| 1/2" Round Shank, Capacity 1/4" to 2" | 44295 |
| Square Shank, Capacity 1/4" to 1-1/4" | 44280 |
| Square Shank, Capacity 1/4" to 2" | 44285 |

Hole Saws & Accessories

Bi-Metal & Carbide Tipped Hole Saws

Features

- 1-1/8" depth of cut
- Continuous welded cup
- M3 HSS Molybdenum electron beam welded cutting edge



| Diameter Inches | Pipe Tap Size | Pipe Entr. Size Inches | Bi-Metal Boxed | Bi-Metal Carded | Carbide Tipped | Diameter Inches | Pipe Tap Size | Pipe Entr. Size Inches | Bi-Metal Boxed | Bi-Metal Carded | Carbide Tipped |
|-----------------|---------------|------------------------|----------------|-----------------|----------------|-----------------|---------------|------------------------|----------------|-----------------|----------------|
| 9/16" | 3/8" | 1/4" | 80701 | 80901 | - | 2-1/4" | 2" | - | 80757 | 80957 | 81057 |
| 5/8 | - | - | 80703 | 80903 | - | 2-5/16 | - | - | 80759 | 80959 | - |
| 11/16 | - | - | 80705 | 80905 | - | 2-3/8 | - | - | 80761 | 80961 | - |
| 3/4 | 1/2 | 3/8 | 80707 | 80907 | 81007 | 2-1/2 | - | 2 | 80763 | 80963 | 81063 |
| 13/16 | - | - | 80709 | 80909 | - | 2-5/8 | 2-1/2 | - | 80765 | - | - |
| 7/8 | 3/4 | 1/2 | 80711 | 80911 | 81011 | 2-3/4 | - | - | 80767 | - | - |
| 15/16 | - | - | 80713 | 80913 | - | 2-7/8 | - | - | 80769 | - | - |
| 1 | - | - | 80715 | 80915 | 81015 | 3 | - | 2-1/2 | 80771 | - | 81071 |
| 1-1/16 | - | - | 80717 | 80917 | - | 3-1/8 | - | - | 80773 | - | - |
| 1-1/8 | 1 | 3/4 | 80719 | 80919 | 81019 | 3-1/4 | 3 | - | 80775 | - | - |
| 1-3/16 | - | - | 80721 | 80921 | - | 3-3/8 | - | - | 80777 | - | - |
| 1-1/4 | - | - | 80729 | 80929 | 81029 | 3-1/2 | - | - | 80779 | - | 81079 |
| 1-5/16 | - | - | 80731 | 80931 | - | 3-5/8 | - | 3 | 80781 | - | - |
| 1-3/8 | - | 1 | 80733 | 80933 | 81033 | 3-3/4 | 3-1/2 | - | 80783 | - | - |
| 1-7/16 | - | - | 80735 | 80935 | - | 3-7/8 | - | - | 80785 | - | - |
| 1-1/2 | 1-1/4 | - | 80737 | 80937 | 81037 | 4 | - | - | 80787 | - | - |
| 1-9/16 | - | - | 80739 | 80939 | - | 4-1/8 | - | 3-1/2 | 80789 | - | - |
| 1-5/8 | - | - | 80741 | 80941 | - | 4-1/4 | 4 | - | 80791 | - | 81091 |
| 1-11/16 | - | - | 80743 | 80943 | - | 4-3/8 | - | - | 80793 | - | - |
| 1-3/4 | 1-1/2 | 1-1/4 | 80745 | 80945 | 81045 | 4-1/2 | - | 4 | 80795 | - | - |
| 1-13/16 | - | - | 80747 | 80947 | - | 4-3/4 | 4-1/2 | - | 80797 | - | - |
| 1-7/8 | - | - | 80749 | 80949 | - | 5 | - | - | 80799 | - | - |
| 2 | - | 1-1/2 | 80751 | 80951 | 81051 | 5-1/2 | - | - | 80803 | - | - |
| 2-1/16 | - | - | 80753 | 80953 | - | 5-3/4 | - | 5 | 80805 | - | - |
| 2-1/8 | - | - | 80755 | 80955 | - | 6 | - | - | 80807 | - | - |

Hole Saw Mandrels & Accessories

Mandrels

| Fits Hole Saw Sizes | Fits Chuck Sizes | Shank Size | Product Number | |
|---------------------|------------------|------------|----------------|--------|
| | | | Boxed | Carded |
| 9/16" to 1-3/16" | 1/4" | 1/4" Round | 81230 | 81330 |
| 9/16" to 1-3/16" | 3/8 | 3/8" Hex | 81236 | 81336 |
| 9/16" to 1-3/16" | 1/2 | 7/16" Hex | 81238 | 81338 |
| 1-1/4" to 6" | 3/8 | 3/8" Hex | 81240 | 81340 |
| 1-1/4" to 6" | 1/2 | 7/16" Hex | 81242 | 81342 |



Accessories

| Description | Product Number |
|---|----------------|
| 12" Extension | 81402 |
| Mandrel Adapter. 1/2-20 I.D x 5/8-18 O.D. | 81404 |
| 1/4" Pilot 4" Overall length for 81330 | 81406 |
| 1/4" Pilot Drill. 3-1/8" Overall length. Fits all mandrels except 81230 | 81408 |
| 1/4" Pilot-alternate style. 3-1/8" Overall length | 81407 |

5 Piece Mechanics Kit

This kit contains five popular Bi-Metal HSS Hole Saws for a large variety of installation and maintenance applications.

Sizes: 7/8", 1", 1-1/8", 1-1/4", & 1-1/2"

Includes: #81230 Mandrel. High Density Polyethelene Case.

| Description | Product Number |
|-----------------------|----------------|
| 5 Piece Mechanics Kit | 81500 |

6 Piece Electrician Kit

Compact kit containing six Bi-Metal HSS Hole Saws most often needed for pipe and conduit entrance.

Sizes: 7/8", 1-1/8", 1-3/8", 1-3/4", 2", & 2-1/2"

Includes: #81238 and #81240 Mandrels. High Density Polyethelene Case.

| Description | Product Number |
|-------------------------|----------------|
| 6 Piece Electrician Kit | 81510 |

6 Piece Plumber Kit

Compact kit containing six Bi-Metal HSS Hole Saws used for pipe and tap entrance.

Sizes: 3/4", 7/8", 1-1/8", 1-1/2", 1-3/4", & 2-1/4"

Includes: #81238 and #81242 Mandrels. High Density Polyethelene Case.

| Description | Product Number |
|---------------------|----------------|
| 6 Piece Plumber Kit | 81515 |

9 Piece Maintenance Kit

A deluxe kit for plumbers, electricians & industrial or general maintenance. Kit contains 9 Bi-Metal HSS Hole Saws covering the most popular sizes.

Sizes: 3/4", 7/8", 1-1/8", 1-3/8", 1-1/2", 1-3/4", 2", 2-1/4", & 2-1/2"

Includes: #81230, #81238 and #81242 Mandrels plus #81402 12" extension.

High Density Polyethelene Case.

| Description | Product Number |
|-------------------------|----------------|
| 9 Piece Maintenance Kit | 81520 |



Steel Stamp Sets

Numerical Sets

Features

- In see-through plastic box
- Number 1 through 8 plus 0 with 6 and 9 reversible
- Individual numbers available upon request



Standard Duty

| Type Size | Stamp Sizes Sq. | Lgth. | Product Number Bulk |
|-----------|-----------------|--------|---------------------|
| 1/16" | 1/4" | 2-3/8" | 44440 |
| 3/32 | 1/4" | 2-3/8 | 44446 |
| 1/8 | 1/4" | 2-3/8 | 44452 |
| 3/16 | 5/16" | 2-7/16 | 44458 |

| Type Size | Stamp Sizes Sq. | Lgth. | Product Number Bulk |
|-----------|-----------------|--------|---------------------|
| 1/4 | 3/8" | 2-9/16 | 44464 |
| 3/8 | 1/2 | 2-7/8 | 44470 |
| 1/2 | 5/8 | 2-7/8 | 44476 |

Heavy Duty

| Type Size | Stamp Sizes Sq. | Lgth. | Product Number Bulk |
|-----------|-----------------|-------|---------------------|
| 1/32" | 1/4" | 2-5/8 | 44386 |
| 3/64 | 1/4 | 2-5/8 | 44390 |
| 1/16 | 5/16 | 2-5/8 | 44394 |
| 3/32 | 5/16 | 2-5/8 | 44398 |
| 1/8 | 5/16 | 2-5/8 | 44402 |
| 5/32 | 3/8 | 2-3/4 | 44406 |

| Type Size | Stamp Sizes Sq. | Lgth. | Product Number Bulk |
|-----------|-----------------|--------|---------------------|
| 3/16 | 3/8" | 2-3/4" | 44410 |
| 1/4 | 7/16 | 2-7/8 | 44414 |
| 5/16 | 1/2 | 2-7/8 | 44418 |
| 3/8 | 5/8 | 3-5/16 | 44422 |
| 1/2 | 5/8 | 3-5/16 | 44426 |

Steel Stamp Sets

Letter Sets

Features

- In see-through plastic box
- Letters A through Z plus "&" sign
- Individual letters available upon request



Standard Duty

| Type Size | Stamp Sizes Sq. | Lgth. | Product Number Bulk |
|-----------|-----------------|--------|---------------------|
| 1/16" | 1/4" | 2-3/8" | 44442 |
| 3/32 | 1/4" | 2-3/8 | 44448 |
| 1/8 | 1/4" | 2-3/8 | 44454 |
| 3/16 | 5/16" | 2-7/16 | 44460 |

| Type Size | Stamp Sizes Sq. | Lgth. | Product Number Bulk |
|-----------|-----------------|--------|---------------------|
| 1/4 | 3/8" | 2-9/16 | 44466 |
| 3/8 | 1/2 | 2-7/8 | 44472 |
| 1/2 | 5/8 | 2-7/8 | 44478 |

Heavy Duty

| Type Size | Stamp Sizes Sq. | Lgth. | Product Number Bulk |
|-----------|-----------------|-------|---------------------|
| 1/32" | 1/4" | 2-5/8 | 44388 |
| 3/64 | 1/4 | 2-5/8 | 44392 |
| 1/16 | 5/16 | 2-5/8 | 44396 |
| 3/32 | 5/16 | 2-5/8 | 44400 |
| 1/8 | 5/16 | 2-5/8 | 44404 |
| 5/32 | 3/8 | 2-3/4 | 44408 |

| Type Size | Stamp Sizes Sq. | Lgth. | Product Number Bulk |
|-----------|-----------------|--------|---------------------|
| 3/16 | 3/8" | 2-3/4" | 44412 |
| 1/4 | 7/16 | 2-7/8 | 44416 |
| 5/16 | 1/2 | 2-7/8 | 44420 |
| 3/8 | 5/8 | 3-5/16 | 44424 |
| 1/2 | 5/8 | 3-5/16 | 44428 |

Steel Stamp Sets

Low Stress · Heavy Duty Gothic

Features

- In see-through plastic box
- Rounded faces and absence of sharp corners on characters minimize impression stress.



| Type Size | Stamp Sizes | | Product Number | |
|-----------|-------------|--------|----------------|------------|
| | Sq. | Lgth. | Numeral Set | Letter Set |
| 1/8" | 5/16" | 2-5/8" | 44500 | 44502 |
| 3/16" | 3/8 | 2-3/4 | 44504 | 44506 |
| 1/4" | 7/16 | 2-7/8 | 44508 | 44510 |
| 3/8" | 5/8 | 3-5/16 | 44512 | 44514 |

Steel Stamp Sets

Positive Identification · Low Stress

Features

- In see-through plastic box
- Uniquely designed characters assure positive identification, even with only part of the impression visible.



| Type Size | Stamp Sizes | | Product Number | |
|-----------|-------------|--------|----------------|------------|
| | Sq. | Lgth. | Numeral Set | Letter Set |
| 1/8" | 5/16" | 2-5/8" | 44520 | |
| 3/16" | 3/8 | 2-3/4 | 44522 | |
| 1/4" | 7/16 | 2-7/8 | 44524 | |

Steel Stamp Sets

Reversed · Heavy Duty Gothic

Features

- In see-through plastic box
- Heavy Duty Gothic
- Hand Made



| Type Size | Stamp Sizes | | Product Number | |
|-----------|-------------|-------|----------------|------------|
| | Sq. | Lgth. | Numeral Set | Letter Set |
| 1/32" | 1/4" | 2-5/8 | 44530 | 44532 |
| 3/64 | 1/4 | 2-5/8 | 44534 | 44536 |
| 1/16 | 5/16 | 2-5/8 | 44538 | 44540 |
| 3/32 | 5/16 | 2-5/8 | 44542 | 44544 |
| 1/8 | 5/16 | 2-5/8 | 44546 | 44548 |
| 5/32 | 3/8 | 2-3/4 | 44550 | 44552 |

| Type Size | Stamp Sizes | | Product Number | |
|-----------|-------------|--------|----------------|------------|
| | Sq. | Lgth. | Numeral Set | Letter Set |
| 3/16 | 3/8" | 2-3/4" | 44554 | 44556 |
| 1/4 | 7/16 | 2-7/8 | 44558 | 44560 |
| 5/16 | 1/2 | 2-7/8 | 44562 | 44564 |
| 3/8 | 5/8 | 3-5/16 | 44566 | 44568 |
| 1/2 | 5/8 | 3-5/16 | 44570 | 44572 |



Flat Files

- A general purpose double cut "workhorse" file
- Ideally suited for rapid stock removal
- Boxed or carded for display

| Size | Bastard | Carded | | |
|------|---------|---------|---------|--------|
| | | Bastard | 2nd Cut | Smooth |
| 6" | 56300 | - | 56600 | 56800 |
| 8" | 56302 | 56202 | 56602 | 56802 |
| 10" | 56304 | 56204 | 56604 | 56804 |
| 12" | 56306 | - | 56606 | 56806 |
| 14" | 56308 | - | 56608 | 56808 |

Mill Files

- For sharpening cutting tools such as sas, shears, lawnmowers, axes, farm tools, etc. Single cut for smooth finish. Boxed or carded for display

| Size | Bastard | Carded | | |
|------|---------|---------|---------|--------|
| | | Bastard | 2nd Cut | Smooth |
| 6" | 56310 | - | 56610 | 56810 |
| 8" | 56312 | 56212 | 56612 | 56812 |
| 10" | 56314 | 56214 | 56614 | 56814 |
| 12" | 56316 | - | 56616 | 56816 |
| 14" | 56318 | - | 56618 | 56818 |

Half Round Files

- Double cut for flat filing and for filing out concave surfaces and for rounding out holes.
- Boxed or carded for display

| Size | Bastard | Carded | | |
|------|---------|---------|---------|--------|
| | | Bastard | 2nd Cut | Smooth |
| 6" | 56320 | - | 56620 | 56820 |
| 8" | 56322 | 56222 | 56622 | 56822 |
| 10" | 56324 | 56224 | 56624 | 56824 |
| 12" | 56326 | - | 56626 | 56826 |
| 14" | 56328 | - | 56628 | 56828 |

Flat Wood Rasps

- 2nd cut style medium coarse teeth are suitable for general purpose use on wood.
- Available boxed or individually carded for display

| Description | Bulk | Carded |
|-------------|-------|--------|
| 8" | 56010 | 56110 |
| 10" | 56012 | 56112 |

Half Round Wood Rasps

- 2nd cut style medium coarse teeth are suitable for general purpose use on wood.
- Available boxed or individually carded for display

| Description | Bulk | Carded |
|-------------|-------|--------|
| 8" | 56020 | 56120 |
| 10" | 56022 | 56122 |

Chain Saw Files

| Description | Product Number |
|--------------------|----------------|
| 1/8" x 6" | 56404 |
| 5/32" x 6" | 56406 |
| 3/16" x 8" | 56408 |
| 13/64" 8" | 56410 |
| 7/32" 8" | 56412 |
| 1/4" x 8" | 56414 |
| 5/32" (pouch of 2) | 56416 |
| 7/32" (pouch of 2) | 56418 |

Round Files

For enlarging holes or rounding out grooves too small for a half round file. Double cut with taper towards the point for use on various sized holes.



| Size | Bastard | Carded | | |
|------|---------|---------|---------|--------|
| | | Bastard | 2nd Cut | Smooth |
| 6" | 56330 | - | 56630 | 56830 |
| 8" | 56332 | 56232 | 56632 | 56832 |
| 10" | 56334 | 56234 | 56634 | 56834 |
| 12" | 56336 | - | 56636 | 56836 |
| 14" | 56338 | - | 56638 | 56838 |

Tapered Files

- Triangular shape and tapered toward the point
- Single cut for smooth finish
- Boxed or individually carded for display

| Description | Bulk | Carded |
|------------------------|-------|--------|
| 6" Slim Taper | 56340 | 56240 |
| 8" Slim Taper | 56342 | 56242 |
| 6" Extra Slim Taper | 56344 | 56244 |
| 8" Extra Slim Taper | 56346 | 56246 |
| 6" Double X-Slim Taper | 56348 | 56248 |
| 8" Double X-Slim Taper | 56350 | 56250 |

4-in-1 "Shoe" Rasp

A versatile tool with a file and rasp section on the flat side and a file and rasp section on the half round side.

| Description | Bulk | Carded |
|-------------|-------|--------|
| 8" | 56030 | 56130 |
| 10" | 56032 | 56132 |

File Handles

- High quality wood handles. Sizes to fit all files shown
- Available boxed or individually carded for display

| Description | Bulk | Carded |
|-------------|-------|--------|
| 6"-8" | 55900 | 55920 |
| 8"-12" | 55902 | 55922 |
| 12"-16" | 55904 | - |



File Card

- For general cleaning of file teeth. Extends file life and improves efficiency.
- Available boxed or individually carded for display

| Description | Bulk |
|---------------------|-------|
| 8" File Card-Boxed | 55910 |
| 8" File Card-Carded | 55930 |



Wood and Composition Cutting - Standard

| Length Inches | TPI | Bulk | Card of 5 | Card of 1 |
|------------------|-----|-------|--------------|--------------|
| 6" | 6 | 80301 | 80401 | 80501 |
| 9" | 3 | 80303 | 80403 | 80503 |
| 12" | 6 | 80305 | 80405 | 80505 |

Wood and Composition Cutting - Deluxe

| Length Inches | TPI | Bulk | Card of 5 | Card of 1 |
|------------------|-----|-------|--------------|--------------|
| 6" | 6 | 80307 | 80407 | 80507 |
| 12" | 6 | 80309 | 80409 | 80509 |



Nail Embedded Wood Cutting - Tooth Hardened-Flexible Back

| Length Inches | TPI | Bulk | Card of 5 | Card of 1 |
|------------------|-----|-------|--------------|--------------|
| 6" | 6 | 80317 | 80417 | 80517 |
| 6" | 10 | 80319 | 80419 | 80519 |
| 12" | 6 | 80321 | 80421 | 80521 |

Plaster Cutting - Tooth Hardened-Flexible Back

| Length Inches | TPI | Bulk | Card of 5 | Card of 1 |
|------------------|-----|-------|--------------|--------------|
| 6" | 6 | 80325 | 80425 | 80525 |

Metal Scroll - High Speed Steel

| Length Inches | TPI | Bulk | Card of 5 | Card of 1 |
|------------------|-----|-------|--------------|--------------|
| 2-1/2" | 18 | 80331 | 80431 | 80531 |
| 4" | 18 | 80333 | 80433 | 80533 |

Metal Cutting - High Speed Steel

| Length Inches | TPI | Bulk | Card of 5 | Card of 1 |
|------------------|-----|-------|--------------|--------------|
| 2-1/2" | 14 | 80341 | 80441 | 80541 |
| 4" | 14 | 80343 | 80443 | 80543 |
| 6" | 14 | 80345 | 80445 | 80545 |
| 2-1/2" | 18 | 80347 | 80447 | 80547 |
| 4" | 18 | 80349 | 80449 | 80549 |
| 6" | 18 | 80351 | 80451 | 80551 |
| 4" | 24 | 80353 | 80453 | 80553 |
| 6" | 24 | 80355 | 80455 | 80555 |

Plaster Cutting - Bi-Metal

| Length Inches | TPI | Bulk | Card of 5 | Card of 1 |
|------------------|-----|-------|--------------|--------------|
| 6" | 6 | 80375 | 80475 | 80575 |

Contour Cutting - Bi-Metal

| Length Inches | TPI | Bulk | Card of 5 | Card of 1 |
|------------------|-----|-------|--------------|--------------|
| 3-1/2" | 14 | 80377 | 80477 | 80577 |
| 3-1/2" | 18 | 80378 | 80478 | 80578 |

Wood/Metal Cutting - Bi-Metal

| Length Inches | TPI | Bulk | Card of 5 | Card of 1 |
|------------------|-------|-------|--------------|--------------|
| 9" | 10/14 | 80377 | 80477 | 80577 |

Nail Embedded Wood Cutting · Bi-Metal

| Length Inches | TPI | Bulk | Card of 5 | Card of 1 |
|---------------|-----|-------|-----------|-----------|
| 6" | 6 | 80361 | 80461 | 80561 |
| 9" | 6 | 80360 | 80460 | 80560 |
| 12" | 6 | 80359 | 80459 | 80559 |
| 6" | 6 | 80362 | 80462 | 80562 |
| 6" | 6 | 80356 | 80456 | 80556 |
| 6" | 10 | 80357 | 80457 | 80557 |
| 9" | 10 | 80358 | 80458 | 80558 |

Metal Cutting · Bi-Metal

| Length Inches | TPI | Bulk | Card of 5 | Card of 1 |
|---------------|-----|-------|-----------|-----------|
| 4" | 14 | 80363 | 80463 | 80563 |
| 6" | 14 | 80365 | 80465 | 80565 |
| 9" | 14 | 80366 | 80466 | 80566 |
| 12" | 14 | 80374 | 80474 | 80574 |
| 4" | 18 | 80367 | 80467 | 80567 |
| 6" | 18 | 80369 | 80469 | 80569 |
| 9" | 18 | 80370 | 80470 | 80570 |
| 4" | 24 | 80371 | 80471 | 80571 |
| 6" | 24 | 80373 | 80473 | 80573 |

Jig Saw Blade Sets

6 Piece Wood Cutting Asst.

- Contains each of six different wood cutting jig saw blades as follows: Nos. 79320, 79324, 79342, 79344, 79346, 79350

| Description | Product Number |
|----------------------------|----------------|
| 6 Piece Wood Cutting Asst. | 79504 |

6 Piece Metal Cutting Asst.

- Contains each of six different HSS metal cutting jig saw blades as follows: Nos. 79370, 79372, 79374, 79376, 79380, 79382.

| Description | Product Number |
|-----------------------------|----------------|
| 6 Piece Metal Cutting Asst. | 79508 |

8 Piece Value Pack Asst.

- Contains each of eight different jig saw blades for cutting wood, metal, plastics and plaster as follows: No. 79330, 79342, 79344, 79350, 79370, 79372, 79376, and 79382.

| Description | Product Number |
|--------------------------|----------------|
| 8 Piece Value Pack Asst. | 79512 |

6 Piece Bi-Metal Cutting Asst.

- Contains each of six different bi-metal jig saw blades as follows: No. 79386, 79388, 79390, 79392, 79394, and 79396.

| Description | Product Number |
|--------------------------------|----------------|
| 6 Piece Bi-Metal Cutting Asst. | 79516 |



Hex Key Wrenches

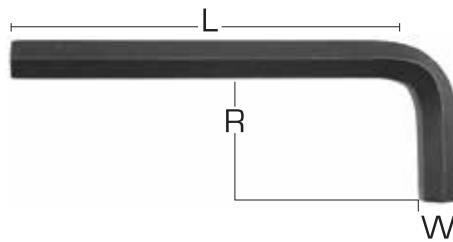

Short Arm Style

| Size Across Flats (W) | Length (R) | Length (L) | Shelf Pack | Product Number | Size Across Flats (W) | Length (R) | Length (L) | Shelf Pack | Product Number |
|--------------------------|------------|------------|------------|-------------------|--------------------------|------------|------------|------------|-------------------|
| .028 | .219" | 1.219" | 10 | 72501 | 7/32" | 1.031" | 3.000" | 10 | 72514 |
| .035 | .344 | 1.219 | 10 | 72502 | 1/4 | 1.125 | 3.250 | 10 | 72516 |
| .050 | .531 | 1.656 | 10 | 72503 | 5/16 | 1.250 | 3.750 | 10 | 72520 |
| 1/16 | .562 | 1.750 | 10 | 72504 | 3/8 | 1.375 | 4.250 | 10 | 72524 |
| 5/64 | .609 | 1.875 | 10 | 72505 | 7/16 | 1.500 | 4.750 | 5 | 72528 |
| 3/32 | .656 | 2.000 | 10 | 72506 | 1/2 | 1.625 | 5.250 | 5 | 72532 |
| 7/64 | .703 | 2.215 | 10 | 72507 | 9/16 | 1.750 | 5.750 | 1 | 72536 |
| 1/8 | .750 | 2.250 | 10 | 72508 | 5/8 | 1.875 | 6.250 | 1 | 72540 |
| 9/64 | .796 | 2.375 | 10 | 72509 | 3/4 | 2.125 | 7.250 | 1 | 72548 |
| 5/32 | .844 | 2.500 | 10 | 72510 | 7/8 | 2.375 | 8.250 | 1 | 72556 |
| 3/16 | .938 | 2.750 | 10 | 72512 | 1 | 2.625 | 9.250 | 1 | 72564 |

Long Arm Style

| Size Across Flats (W) | Length (R) | Length (L) | Shelf Pack | Product Number | Size Across Flats (W) | Length (R) | Length (L) | Shelf Pack | Product Number |
|--------------------------|------------|------------|------------|-------------------|--------------------------|------------|------------|------------|-------------------|
| .035" | .344" | 2.672" | 10 | 72602 | 1/4" | 1.125" | 3.250 | 10 | 72616 |
| .050 | .531 | 2.844 | 10 | 72603 | 5/16 | 1.250 | 3.750 | 10 | 72620 |
| 1/16 | .562 | 3.000 | 10 | 72604 | 3/8 | 1.375 | 4.250 | 10 | 72624 |
| 5/64 | .609 | 3.188 | 10 | 72605 | 7/16 | 1.500 | 4.750 | 5 | 72628 |
| 3/32 | .656 | 3.375 | 10 | 72606 | 1/2 | 1.625 | 5.250 | 5 | 72632 |
| 7/64 | .703 | 3.562 | 10 | 72607 | 9/16 | 1.750 | 5.750 | 1 | 72636 |
| 1/8 | .750 | 3.750 | 10 | 72608 | 5/8 | 1.875 | 6.250 | 1 | 72640 |
| 9/64 | .796 | 3.960 | 10 | 72609 | 3/4 | 2.125 | 7.250 | 1 | 72648 |
| 5/32 | .844 | 4.125 | 10 | 72610 | 7/8 | 2.375 | 8.250 | 1 | 72656 |
| 3/16 | .938 | 4.500 | 10 | 72612 | 1 | 2.625 | 9.250 | 1 | 72664 |
| 7/32 | 1.031 | 3.000 | 10 | 72614 | | | | | |

6" Long (black finish)

| Size Across Flats (W) | Length (R) | Length (L) | Shelf Pack | Product Number | Size Across Flats (W) | Length (R) | Length (L) | Shelf Pack | Product Number |
|--------------------------|------------|------------|------------|-------------------|--------------------------|------------|------------|------------|-------------------|
| 5/64" | .609 | 6.000" | 10 | 72705 | 5/16 | 1.250 | 6.000" | 10 | 72720 |
| 3/32 | .656 | 6.000 | 10 | 72706 | 3/8 | 1.375 | 6.000 | 10 | 72724 |
| 7/64 | .703 | 6.000 | 10 | 72707 | 5/64 | .609 | 12.000 | 10 | 72770 |
| 1/8 | .750 | 6.000 | 10 | 72708 | 3/32 | .656 | 12.000 | 10 | 72772 |
| 9/64 | .796 | 6.000 | 10 | 72709 | 1/8 | .750 | 12.000 | 10 | 72774 |
| 5/32 | .844 | 6.000 | 10 | 72710 | 5/32 | .844 | 12.000 | 10 | 72776 |
| 3/16 | .938 | 6.000 | 10 | 72712 | 3/16 | .938 | 12.000 | 10 | 72778 |
| 7/32 | 1.031 | 6.000 | 10 | 72714 | 7/32 | 1.031 | 12.000 | 10 | 72780 |
| 1/4 | 1.125 | 6.000 | 10 | 72716 | 1/4 | 1.125 | 12.000 | 10 | 72782 |

Metric Short Arm Style

| Size Across | | | | Product Number | Size Across | | | | Product Number |
|-------------|------------|------------|------------|----------------|-------------|------------|------------|------------|----------------|
| Flats (W) | Length (R) | Length (L) | Shelf Pack | | Flats (W) | Length (R) | Length (L) | Shelf Pack | |
| 0.7 | 8 | 34 | 10 | 72802 | 5.0 | 28 | 80 | 10 | 72818 |
| 0.9 | 11 | 34 | 10 | 72804 | 6.0 | 32 | 90 | 10 | 72820 |
| 1.3 | 16 | 44 | 10 | 72806 | 8.0 | 36 | 100 | 10 | 72824 |
| 1.5 | 14 | 45 | 10 | 72808 | 10.0 | 40 | 112 | 10 | 72830 |
| 2.0 | 16 | 50 | 10 | 72810 | 12.0 | 45 | 125 | 10 | 72834 |
| 2.5 | 18 | 56 | 10 | 72812 | 14.0 | 56 | 140 | 10 | 72836 |
| 3.0 | 20 | 63 | 10 | 72814 | 17.0 | 63 | 160 | 10 | 72844 |
| 4.0 | 25 | 70 | 10 | 72816 | | | | | |

Metric Long Arm Style

| Size Across | | | | Product Number | Size Across | | | | Product Number |
|-------------|------------|------------|------------|----------------|-------------|------------|------------|------------|----------------|
| Flats (W) | Length (R) | Length (L) | Shelf Pack | | Flats (W) | Length (R) | Length (L) | Shelf Pack | |
| 0.7 | 8 | 34 | 10 | 72902 | 5.0 | 28 | 118 | 10 | 72918 |
| 0.9 | 11 | 71 | 10 | 72904 | 6.0 | 32 | 140 | 10 | 72920 |
| 1.3 | 16 | 75 | 10 | 72906 | 8.0 | 36 | 160 | 10 | 72924 |
| 1.5 | 14 | 78 | 10 | 72908 | 10.0 | 40 | 170 | 10 | 72930 |
| 2.0 | 16 | 83 | 10 | 72910 | 12.0 | 45 | 212 | 10 | 72934 |
| 2.5 | 18 | 90 | 10 | 72912 | 14.0 | 56 | 236 | 10 | 72936 |
| 3.0 | 20 | 100 | 10 | 72914 | 17.0 | 63 | 250 | 10 | 72944 |
| 4.0 | 25 | 106 | 10 | 72916 | 19.0 | 70 | 280 | 10 | 72948 |

TORX®-Short Arm Style

| Description | Shelf Pack | Product Number | Description | Shelf Pack | Product Number |
|-------------|------------|----------------|-------------|------------|----------------|
| T-7 | 10 | 72960 | T-27 | 10 | 72974 |
| T-8 | 10 | 72962 | T-30 | 10 | 72976 |
| T-9 | 10 | 72964 | T-40 | 5 | 72978 |
| T-10 | 10 | 72966 | T-45 | 5 | 72980 |
| T-15 | 10 | 72968 | T-50 | 5 | 72982 |
| T-20 | 10 | 72970 | T-55 | 5 | 72984 |
| T-25 | 10 | 72972 | | | |

Ball End L-Wrenches

Ball End L-Wrenches (open stock)

Inch Sizes

| Socket Size (Width Across Flats) | Length of Long Arm | Shelf Pack | Product Number |
|-------------------------------------|-----------------------|---------------|-------------------|
| .050" | 2.8" | 6 | 74002 |
| 1/16 | 3.0 | 6 | 74004 |
| 5/64 | 3.2 | 6 | 74006 |
| 3/32 | 3.4 | 6 | 74008 |
| 7/64 | 3.6 | 6 | 74010 |
| 1/8 | 3.7 | 6 | 74012 |
| 9/64 | 3.9 | 6 | 74014 |
| 5/32 | 4.1 | 6 | 74016 |
| 3/16 | 4.5 | 6 | 74018 |

| Socket Size (Width Across Flats) | Length of Long Arm | Shelf Pack | Product Number |
|-------------------------------------|-----------------------|---------------|-------------------|
| 7/32 | 4.9 | 6 | 74020 |
| 1/4 | 5.2 | 6 | 74022 |
| 5/16 | 6.0 | 6 | 74024 |
| 3/8 | 6.7 | 6 | 74026 |
| 7/16 | 7.5 | 6 | 74028 |
| 1/2 | 8.2 | 6 | 74030 |
| 9/16 | 9.0 | 6 | 74032 |
| 5/8 | 9.7 | 6 | 74034 |
| 3/4 | 11.2 | 6 | 74036 |

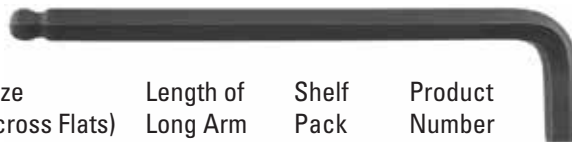

Metric Sizes

| Socket Size (Width Across Flats) | Length of Long Arm | Shelf Pack | Product Number |
|-------------------------------------|-----------------------|---------------|-------------------|
| M1.27 | 2.8" | 6 | 74049 |
| M1.5 | 3.1 | 6 | 74050 |
| M2 | 3.3 | 6 | 74052 |
| M2.5 | 3.5 | 6 | 74054 |
| M3 | 3.7 | 6 | 74056 |
| M3.5 | 3.9 | 6 | 74058 |
| M4 | 4.3 | 6 | 74060 |
| M4.5 | 4.7 | 6 | 74062 |
| M5 | 5.1 | 6 | 74064 |
| M5.5 | 5.5 | 6 | 74066 |

| Socket Size (Width Across Flats) | Length of Long Arm | Shelf Pack | Product Number |
|-------------------------------------|-----------------------|---------------|-------------------|
| M6 | 5.9 | 6 | 74068 |
| M7 | 6.1 | 6 | 74070 |
| M8 | 6.7 | 6 | 74072 |
| M9 | 7.1 | 6 | 74074 |
| M10 | 7.5 | 6 | 74076 |
| M11 | 7.9 | 6 | 74078 |
| M12 | 8.7 | 6 | 74080 |
| M14 | 10.2 | 6 | 74084 |
| M17 | 11.0 | 6 | 74086 |
| M19 | 11.6 | 6 | 74088 |

Hex Key Wrenches, L-Type

Hex Key Wrench Sets L-Type

| Description | Product Number |
|--|----------------|
| 7 Piece Hex Key Set-Short Arm (Sizes: 5/64, 3/32, 1/8, 5/32, 3/16, 7/32, 1/4) | 72470 |
| 7 piece Hex Key Set-Long Arm (Sizes: 5/64, 3/32, 1/8, 5/32, 3/16, 7/32, 1/4) | 72472 |
| 9 piece Hex Key Set-Long Arm (Sizes: 5/64, 3/32, 1/8, 5/32, 3/16, 7/32, 1/4, 5/16, 3/8) | 72474 |
| 10 piece Hex Key Set-Short Arm (Sizes: .050, 1/16, 5/64, 3/32) Long Arm Sizes: 1/8, 5/32, 3/16, 7/32, 1/4, 5/16) | 72476 |
| 18 piece Combination Hex Key Set-Short Arm (Sizes: .050, 1/16, 5/64, 3/32, 1/8, 5/32, 3/16, 7/32, 1/4) Long Arm Sizes: 5/64, 3/32, 1/8, 5/32, 3/16, 7/32, 1/4, 5/16, 3/8) | 72478 |

Metric Hex Key Wrench Sets L-Type

| Description | Product Number |
|--|----------------|
| 7 Piece Metric Hex Key Set (Short Arm Sizes: M2, M2.5, M3, M4, M5, M6, and M8) | 72954 |
| 10 Piece Metric Hex Key Set (Short Arm Sizes: M1.5, M2, M2.5, M3, M4, M5, M6, M7, M8, M10) | 72956 |

TORX® Hex Key Wrench Sets L-Type

| Description | Shelf Pack | Product Number |
|---|------------|----------------|
| 9 piece Torx® Hex Key Set (Short Arm Sizes: T10, T15, T20, T25, T27, T30, T40, T45, T50) | 1 | 72990 |
| 13 piece Torx® Hex Key Set (Short Arm Sizes: T7, T8, T9, T10, T15, T20, T25, T27, T30, T40, T45, T50) | 1 | 72992 |

Thread Gauges for Inch and Metric Screws

These gauges quickly tell the size, pitch (threads per inch), tap drill size, clearance drill size, tap series, length and basic diameter for American, Unified or Metric machine screws and bolts.

| Description | Product Number |
|-----------------------|----------------|
| Gauge for No. 1-5/16" | 51010 |
| Gauge for M2-M7 | 51020 |
| Gauge for M8-M14 | 51030 |



Screw Pitch Gauges

Screw Pitch Gauges

- For quickly identifying U.S. or Metric threads
- Each tool is carded for display

| Description | Product Number |
|------------------------------|----------------|
| U.S. Thread 9 to 40 | 51050 |
| Metric Thread M0.45 to M2.50 | 51055 |

**13 Piece Drill and Tap Set**

- A time-saving threading set which includes the proper drill bits for each of the taps. Packed in an attractive vinyl display pouch.

Includes: 6 wire gauge 135° split point screw machine length HSS drill bits: Nos. 43, 35, 29, 25, 21, and 7, plus 6 plug taps, 4- 40 NC, 6-32 NC, 8-32 NC, 10-24 NC, 10-32 NF and 1/4-20 NC and a T-Handle tap wrench.

| Description | Product Number |
|-----------------------------------|----------------|
| 13 Piece Drilling and Tapping Set | 41095 |



Technical Information

Decimal Equivalents

| Frac. | Num. | Letter | Metric MM | Dec. Equiv. |
|-------|------|--------|-----------|-------------|
| - | 80 | - | - | .0135 |
| - | - | - | .35 | .0138 |
| - | 79 | - | - | .0145 |
| 1/64 | - | - | - | .0156 |
| - | - | - | .40 | .0158 |
| - | 78 | - | - | .0160 |
| - | - | - | .45 | .0177 |
| - | 77 | - | - | .0180 |
| - | - | - | .50 | .0197 |
| - | 76 | - | - | .0200 |
| - | 75 | - | - | .0210 |
| - | - | - | .55 | .0217 |
| - | 74 | - | - | .0225 |
| - | - | - | .60 | .0236 |
| - | 73 | - | - | .0240 |
| - | 72 | - | - | .0250 |
| - | - | - | .65 | .0256 |
| - | 71 | - | - | .0260 |
| - | - | - | .70 | .0276 |
| - | 70 | - | - | .0280 |
| - | 69 | - | - | .0292 |
| - | - | - | .75 | .0295 |
| - | 68 | - | - | .0310 |
| 1/32 | - | - | - | .0312 |
| - | - | - | .80 | .0315 |
| - | 67 | - | - | .0320 |
| - | 66 | - | - | .0330 |
| - | - | - | .85 | .0335 |
| - | 65 | - | - | .0350 |
| - | - | - | .90 | .0354 |
| - | 64 | - | - | .0360 |
| - | 63 | - | - | .0370 |
| - | - | - | .95 | .0374 |
| - | 62 | - | - | .0380 |
| - | 61 | - | - | .0390 |
| - | - | - | 1.00 | .0394 |
| - | 60 | - | - | .0400 |
| - | 59 | - | - | .0410 |
| - | - | - | 1.05 | .0413 |
| - | 58 | - | - | .0420 |
| - | 57 | - | - | .0430 |
| - | - | - | 1.10 | .0433 |
| - | - | - | 1.15 | .0453 |
| - | 56 | - | - | .0465 |
| 3/64 | - | - | - | .0469 |
| - | - | - | 1.20 | .0472 |
| - | - | - | 1.25 | .0492 |
| - | - | - | 1.30 | .0312 |
| - | 55 | - | - | .0520 |
| - | - | - | 1.35 | .0531 |
| - | 54 | - | - | .0550 |
| - | - | - | 1.40 | .0551 |
| - | - | - | 1.45 | .0571 |
| - | - | - | 1.50 | .0591 |
| - | 53 | - | - | .0595 |
| - | - | - | 1.5 | .0610 |

| Frac. | Num. | Letter | Metric MM | Dec. Equiv. |
|-------|------|--------|-----------|-------------|
| 1/16 | - | - | - | .0625 |
| - | - | - | 1.60 | .0630 |
| - | 52 | - | - | .0635 |
| - | - | - | 1.65 | .0650 |
| - | - | - | 1.70 | .0669 |
| - | 51 | - | - | .0670 |
| - | - | - | 1.75 | .0689 |
| - | 50 | - | - | .0700 |
| - | - | - | 1.80 | .0709 |
| - | - | - | 1.85 | .0728 |
| - | 49 | - | - | .0730 |
| - | - | - | 1.90 | .0748 |
| - | 48 | - | - | .0760 |
| - | - | - | 1.95 | .0768 |
| 5/64 | - | - | - | .0781 |
| - | 47 | - | - | .0785 |
| - | - | - | 2.00 | .0787 |
| - | - | - | 2.05 | .0807 |
| - | 46 | - | - | .0810 |
| - | 45 | - | - | .0820 |
| - | - | - | 2.10 | .0827 |
| - | - | - | 2.15 | .0846 |
| - | 44 | - | - | .0860 |
| - | - | - | 2.20 | .0866 |
| - | - | - | 2.25 | .0886 |
| - | 43 | - | - | .0890 |
| - | - | - | 2.30 | .0906 |
| - | - | - | 2.35 | .0925 |
| 3/32 | - | - | - | .0935 |
| - | - | - | 2.40 | .0938 |
| - | - | - | 2.40 | .0945 |
| - | 41 | - | - | .0960 |
| - | - | - | 2.45 | .0965 |
| - | 40 | - | - | .0980 |
| - | - | - | 2.50 | .0984 |
| - | 39 | - | - | .0995 |
| - | 38 | - | - | .1015 |
| - | - | - | 2.60 | .1024 |
| - | 37 | - | - | .1040 |
| - | - | - | 2.70 | .1063 |
| - | 36 | - | - | .1065 |
| - | - | - | 2.75 | .1083 |
| 7/64 | - | - | - | .1094 |
| - | 35 | - | - | .1100 |
| - | - | - | 2.80 | .1102 |
| - | 34 | - | - | .1110 |
| - | 33 | - | - | .1130 |
| - | - | - | 2.90 | .1142 |
| - | 32 | - | - | .1160 |
| - | - | - | 3.00 | .1181 |
| - | 31 | - | - | .1200 |
| - | - | - | 3.10 | .1220 |
| 1/8 | - | - | - | .1250 |
| - | - | - | 3.20 | .1260 |
| - | - | - | 3.25 | .1280 |
| - | 30 | - | - | .1285 |

| Frac. | Num. | Letter | Metric MM | Dec. Equiv. |
|-------|------|--------|-----------|-------------|
| - | - | - | 3.30 | .1299 |
| - | - | - | 3.40 | .1339 |
| - | 29 | - | - | .1360 |
| - | - | - | 3.50 | .1378 |
| - | 28 | - | - | .1405 |
| 9/64 | - | - | - | .1406 |
| - | - | - | 3.60 | .1417 |
| - | 27 | - | - | .1440 |
| - | - | - | 3.70 | .1457 |
| - | 26 | - | - | .1470 |
| - | - | - | 3.75 | .1476 |
| - | 25 | - | - | .1495 |
| - | - | - | 3.80 | .1496 |
| - | 24 | - | - | .1520 |
| - | - | - | 3.90 | .1535 |
| - | 23 | - | - | .1540 |
| 5/32 | - | - | - | .1562 |
| - | 22 | - | - | .1570 |
| - | - | - | 4.00 | .1575 |
| - | 21 | - | - | .1590 |
| - | 20 | - | - | .1610 |
| - | - | - | 4.10 | .1614 |
| - | - | - | 4.20 | .1654 |
| - | 19 | - | - | .1660 |
| - | - | - | 4.25 | .1673 |
| - | - | - | 4.30 | .1693 |
| - | 18 | - | - | .1695 |
| 11/64 | - | - | - | .1719 |
| - | 17 | - | - | .1730 |
| - | - | - | 4.40 | .1732 |
| - | 16 | - | - | .1770 |
| - | - | - | 4.50 | .1772 |
| - | 15 | - | - | .1800 |
| - | - | - | 4.60 | .1811 |
| - | 14 | - | - | .1820 |
| - | 13 | - | - | .1850 |
| - | - | - | 4.70 | .1850 |
| - | - | - | 4.75 | .1870 |
| 3/16 | - | - | - | .1875 |
| - | - | - | 4.80 | .1890 |
| - | 12 | - | - | .1890 |
| - | 11 | - | - | .1910 |
| - | - | - | 4.90 | .1929 |
| - | 10 | - | - | .1935 |
| - | 9 | - | - | .1960 |
| - | - | - | 5.00 | .1968 |
| - | 8 | - | - | .1990 |
| - | - | - | 5.10 | .2008 |
| - | 7 | - | - | .2010 |
| 13/64 | - | - | - | .2031 |
| - | 6 | - | - | .2040 |
| - | - | - | 5.20 | .2047 |
| - | 5 | - | - | .2055 |
| - | - | - | 5.25 | .2067 |
| - | - | - | 5.30 | .2087 |
| - | 4 | - | - | .2090 |



Decimal Equivalents

| Frac. | Num. | Letter | Metric MM | Dec. Equiv. |
|-------|------|--------|-----------|-------------|
| - | - | - | 5.40 | .2126 |
| - | 3 | - | - | .2130 |
| - | - | - | 5.50 | .2165 |
| 7/32 | - | - | - | .2188 |
| - | - | - | 5.60 | .2205 |
| - | 2 | - | - | .2210 |
| - | - | - | 5.70 | .2244 |
| - | - | - | 5.75 | .2264 |
| - | 1 | - | - | .2280 |
| - | - | - | 5.80 | .2283 |
| - | - | - | 5.90 | .2323 |
| - | - | A | - | .2340 |
| 15/64 | - | - | - | .2344 |
| - | - | - | 6.00 | .2362 |
| - | - | B | - | .2380 |
| - | - | - | 6.10 | .2402 |
| - | - | C | - | .2420 |
| - | - | - | 6.20 | .2441 |
| - | - | D | - | .2460 |
| - | - | - | 6.25 | .2461 |
| - | - | - | 6.30 | .2480 |
| 1/4 | - | - | - | .2500 |
| - | - | E | - | .2500 |
| - | - | - | 6.40 | .2520 |
| - | - | - | 6.50 | .2559 |
| - | - | F | - | .2570 |
| - | - | - | 6.60 | .2598 |
| - | - | G | - | .2610 |
| - | - | - | 6.70 | .2638 |
| 17/64 | - | - | - | .2656 |
| - | - | - | 6.75 | .2657 |
| - | - | H | - | .2660 |
| - | - | - | 6.80 | .2677 |
| - | - | - | 6.90 | .2717 |
| - | - | I | - | .2720 |
| - | - | - | 7.00 | .2756 |
| - | - | J | - | .2770 |
| - | - | - | 7.10 | .2795 |
| - | - | K | - | .2810 |
| 9/32 | - | - | - | .2812 |
| - | - | - | 7.20 | .2835 |
| - | - | - | 7.25 | .2854 |
| - | - | - | 7.30 | .2874 |
| - | - | L | - | .2900 |
| - | - | - | 7.40 | .2913 |
| - | - | M | - | .2950 |
| - | - | - | 7.50 | .2953 |
| 19/64 | - | - | - | .2969 |
| - | - | - | 7.60 | .2992 |
| - | - | N | - | .3020 |
| - | - | - | 7.70 | .3031 |
| - | - | - | 7.75 | .3051 |
| - | - | - | 7.80 | .3071 |
| - | - | - | 7.90 | .3110 |
| 5/16 | - | - | - | .3125 |
| - | - | - | 8.00 | .3150 |

| Frac. | Num. | Letter | Metric MM | Dec. Equiv. |
|-------|------|--------|-----------|-------------|
| - | - | O | - | .3160 |
| - | - | - | 8.10 | .3189 |
| - | - | - | 8.20 | .3228 |
| - | - | P | - | .3230 |
| - | - | - | 8.25 | .3248 |
| - | - | - | 8.30 | .3268 |
| 21/64 | - | - | - | .3281 |
| - | - | - | 8.40 | .3307 |
| - | - | Q | - | .3320 |
| - | - | - | 8.50 | .3346 |
| - | - | - | 8.60 | .3386 |
| - | - | R | - | .3390 |
| - | - | - | 8.70 | .3425 |
| 11/32 | - | - | - | .3438 |
| - | - | - | 8.75 | .3445 |
| - | - | - | 8.80 | .3465 |
| - | - | S | - | .3480 |
| - | - | - | 8.90 | .3504 |
| - | - | - | 9.00 | .3543 |
| - | - | T | - | .3580 |
| - | - | - | 9.10 | .3583 |
| 23/64 | - | - | - | .3594 |
| - | - | - | 9.20 | .3622 |
| - | - | - | 9.25 | .3642 |
| - | - | - | 9.30 | .3661 |
| - | - | U | - | .3680 |
| - | - | - | 9.40 | .3701 |
| - | - | - | 9.50 | .3740 |
| 3/8 | - | - | - | .3750 |
| - | - | V | - | .3770 |
| - | - | - | 9.60 | .3780 |
| - | - | - | 9.70 | .3819 |
| - | - | - | 9.75 | .3839 |
| - | - | - | 9.80 | .3858 |
| - | - | W | - | .3860 |
| - | - | - | 9.90 | .3898 |
| 25/64 | - | - | - | .3906 |
| - | - | - | 10.00 | .3937 |
| - | - | X | - | .3970 |
| - | - | Y | - | .4040 |
| 13/32 | - | - | - | .4062 |
| - | - | Z | - | .4130 |
| - | - | - | 10.50 | .4134 |
| 27/64 | - | - | - | .4219 |
| - | - | - | 11.00 | .4331 |
| 7/16 | - | - | - | .4375 |
| - | - | - | 11.50 | .4528 |
| 29/64 | - | - | - | .4531 |
| 15/32 | - | - | - | .4688 |
| - | - | - | 12.00 | .4724 |
| 31/64 | - | - | - | .4844 |
| - | - | - | 12.50 | .4921 |
| 1/2 | - | - | - | .5000 |
| - | - | - | 13.00 | .5118 |
| 33/64 | - | - | - | .5156 |
| 17/32 | - | - | - | .5312 |

| Frac. | Num. | Letter | Metric MM | Dec. Equiv. |
|-------|------|--------|-----------|-------------|
| - | - | - | 13.50 | .5315 |
| 36/64 | - | - | - | .5469 |
| - | - | - | 14.00 | .5512 |
| 9/16 | - | - | - | .5625 |
| - | - | - | 14.50 | .5709 |
| 37/64 | - | - | - | .5781 |
| - | - | - | 15.00 | .5906 |
| 19/32 | - | - | - | .5938 |
| 39/64 | - | - | - | .6094 |
| - | - | - | 15.50 | .6102 |
| 5/8 | - | - | - | .6250 |
| - | - | - | 16.00 | .6299 |
| 41/64 | - | - | - | .6406 |
| - | - | - | 16.50 | .6496 |
| 21/32 | - | - | - | .6562 |
| - | - | - | 17.00 | .6693 |
| 43/64 | - | - | - | .6719 |
| 11/16 | - | - | - | .6875 |
| - | - | - | 17.50 | .6890 |
| 45/64 | - | - | - | .7031 |
| - | - | - | 18.00 | .7087 |
| 23/32 | - | - | - | .7188 |
| - | - | - | 18.50 | .7283 |
| 47/64 | - | - | - | .7344 |
| - | - | - | 19.00 | .7480 |
| 3/4 | - | - | - | .7500 |
| 49/64 | - | - | - | .7656 |
| - | - | - | 19.50 | .7677 |
| 25/32 | - | - | - | .7812 |
| - | - | - | 20.00 | .7874 |
| 51/64 | - | - | - | .7969 |
| - | - | - | 20.50 | .8071 |
| 13/16 | - | - | - | .8125 |
| - | - | - | 21.00 | .8268 |
| 53/64 | - | - | - | .8281 |
| 27/32 | - | - | - | .8438 |
| - | - | - | 21.50 | .8465 |
| 55/64 | - | - | - | .8594 |
| - | - | - | 22.00 | .8661 |
| 7/8 | - | - | - | .8750 |
| - | - | - | 22.50 | .8858 |
| 57/64 | - | - | - | .8906 |
| - | - | - | 23.00 | .9055 |
| 29/32 | - | - | - | .9062 |
| 59/64 | - | - | - | .9291 |
| - | - | - | 23.50 | .9252 |
| 15/16 | - | - | - | .9375 |
| - | - | - | 24.00 | .9449 |
| 61/64 | - | - | - | .9531 |
| - | - | - | 24.50 | .9646 |
| 31/32 | - | - | - | .9688 |
| - | - | - | 25.00 | .9843 |
| 63/64 | - | - | - | .9844 |
| 1 | - | - | - | 1.000 |



Technical Information

Tap Drill Sizes

| Tap | Tap Drill | Dec. Equiv. Of Tap Drill |
|---------|-----------|--------------------------|
| 0-80 | 3/64 | .0469 |
| 1-64 | 53 | .0595 |
| 1-72 | 53 | .0595 |
| 2-56 | 50 | .0700 |
| 2-64 | 50 | .0700 |
| 3-48 | 47 | .0785 |
| 3-56 | 45 | .0820 |
| 4-40 | 43 | .0890 |
| 4-48 | 42 | .0935 |
| 1/8-40 | 38 | .1015 |
| 5-40 | 38 | .1015 |
| 5-44 | 37 | .1040 |
| 6-32 | 36 | .1065 |
| 6-40 | 33 | .1130 |
| 8-32 | 29 | .1360 |
| 8-36 | 29 | .1360 |
| 8-40 | 28 | .1405 |
| 3/16-24 | 26 | .1470 |
| 10-24 | 25 | .1495 |
| 3/16-32 | 22 | .1570 |
| 10-32 | 21 | .1590 |

| Tap | Tap Drill | Dec. Equiv. Of Tap Drill |
|---------|-----------|--------------------------|
| 12-24 | 16 | .1770 |
| 12-28 | 14 | .1820 |
| 12-32 | 13 | .1850 |
| 14-20 | 10 | .1935 |
| 1/4-20 | 7 | .2010 |
| 14-24 | 7 | .2010 |
| 1/4-24 | 4 | .2090 |
| 1/4-28 | 3 | .2130 |
| 1/4-32 | 7/32 | .2188 |
| 1/4-40 | 1 | .2280 |
| 5/16-18 | F | .2570 |
| 5/16-24 | I | .2720 |
| 3/8-16 | 5/16 | .3125 |
| 3/8-24 | Q | .3320 |
| 7/16-14 | U | .3680 |
| 7/16-20 | 25/64 | .3906 |
| 1/2-13 | 27/64 | .4219 |
| 1/2-20 | 29/64 | .4531 |
| 1/2-24 | .29/64 | .4531 |
| 9/16-12 | 31/64 | .4844 |
| 9/16-18 | 33/64 | .5156 |

| Tap | Tap Drill | Dec. Equiv. Of Tap Drill |
|----------|-----------|--------------------------|
| 5/8-11 | 17/32 | .5313 |
| 5/8-18 | 37/64 | .5781 |
| 11/16-11 | 19/32 | .5938 |
| 11/16-16 | 5/8 | .6250 |
| 3/4-10 | 21/32 | .6563 |
| 3/4-16 | 11/16 | .6875 |
| 7/8-9 | 49/64 | .7656 |
| 7/8-14 | 13/16 | .8125 |
| 7/8-18 | 53/64 | .8281 |
| 1-8 | 7/8 | .8750 |
| 1-12 | 59/64 | .9219 |
| 1-14 | 15/16 | .9375 |
| 1 1/8-7 | 63/64 | .9844 |
| 1 1/8-12 | 1 3/64 | 1.0469 |
| 1 1/4-7 | 1 1/8 | 1.1250 |
| 1 1/4-12 | 1 11/64 | 1.1719 |
| 1 3/8-6 | 1 15/64 | 1.2344 |
| 1 3/8-12 | 1 19/64 | 1.2969 |
| 1 1/2-6 | 1 23/64 | 1.3594 |
| 1 1/2-12 | 1 27/64 | 1.4219 |

Pipe Tap Sizes

| Tap | Tap Drill | Dec. Equiv. Of Tap Drill |
|--------|-----------|--------------------------|
| 1/8-27 | Q | .3320 |
| 1/4-18 | 7/16 | .4375 |
| 3/8-18 | 9/16 | .5625 |
| 1/2-14 | 45/64 | .7031 |

| Tap | Tap Drill | Dec. Equiv. Of Tap Drill |
|--------------|-----------|--------------------------|
| 3/4-14 | 29/32 | .9062 |
| 1-11 1/2 | 1 9/64 | 1.1406 |
| 1 1/4-11 1/2 | 1 31/64 | 1.4843 |

| Tap | Tap Drill | Dec. Equiv. Of Tap Drill |
|--------------|-----------|--------------------------|
| 1 1/2-11 1/2 | 1 47/64 | 1.7343 |
| 2-11 1/2 | 2 13/64 | 2.2031 |
| 2 1/2-8 | 2 5/8 | 2.6250 |

Metric Sizes

| Tap | Tap Drill | Dec. Equiv. Of Tap Drill |
|-------------|-----------|--------------------------|
| M2 x 0.40 | 52 | .0635 |
| M2.5 x 0.45 | 46 | .0810 |
| M3 x 0.50 | 40 | .0980 |
| | 2.5mm | .0984 |
| M3 x 0.60 | 2.5mm | .0984 |
| M3.5 x 0.60 | 33 | .1130 |
| | 2.9mm | .1142 |
| M4 x 0.70 | 30 | .1285 |
| | 3.3mm | .1299 |
| M4 x 0.75 | 3.44mm | .1388 |
| M4.5 x 0.75 | 26 | .1470 |
| | 3.75mm | .1476 |
| M5 x 0.90 | 4.2mm | .1654 |
| M5 x 0.80 | 19 | .1660 |
| M6 x 1.00 | 9 | .1960 |
| | 5mm | .1968 |
| | 8 | .1990 |
| M7 x 1.00 | 15/64 | .2344 |
| | 6mm | .2362 |
| | B | .2380 |

| Tap | Tap Drill | Dec. Equiv. Of Tap Drill |
|------------|-----------|--------------------------|
| M8 x 1.25 | 17/64 | .2656 |
| | 6.75mm | .2657 |
| | H | .2660 |
| | 6.8mm | .2677 |
| M8 x 1.00 | 7mm | .2756 |
| | J | .2770 |
| M9 x 1.25 | 7.9mm | .3110 |
| M9 x 1.00 | 8.1mm | .3189 |
| M9 x 0.75 | 8.3mm | .3268 |
| M10 x 1.50 | Q | .3320 |
| | 8.5mm | .3346 |
| M10 x 1.25 | 11/32 | .3438 |
| | 8.75mm | .3445 |
| M12 x 1.75 | Y | .4040 |
| | 13/32 | .4062 |
| M12 x 1.25 | 27/64 | .4219 |
| M14 x 2.00 | 15/32 | .4688 |
| | 12mm | .4724 |

| Tap | Tap Drill | Dec. Equiv. Of Tap Drill |
|------------|-----------|--------------------------|
| M14 x 1.50 | 12m5mm | .4921 |
| M14 x 1.25 | 12.8mm | .5039 |
| M16 x 2.00 | 35/64 | .5469 |
| | 14mm | .5512 |
| M16 x 1.50 | 14.5mm | .5709 |
| M18 x 2.50 | 39/64 | .6094 |
| | 15.5mm | .6102 |
| M18 x 1.50 | 16.5mm | .6496 |
| M20 x 2.50 | 11/16 | .6875 |
| | 17.5mm | .6890 |
| M20 x 1.50 | 18.5mm | .7283 |
| M22 x 2.50 | 49/64 | .7656 |
| | 19.5mm | .7677 |
| M22 x 1.50 | 20.5mm | .8071 |
| M24 x 3.00 | 21mm | .8268 |
| | 53/64 | .8281 |
| M24 x 2.00 | 22mm | .8661 |

