

Installation, Operation and Service Instructions

INFRARED OUTDOOR PATIO HEATER

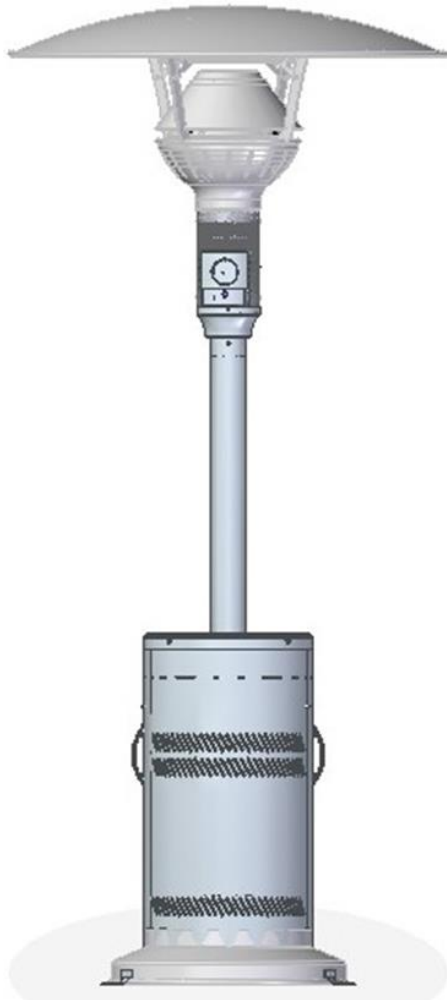

SERIES GA201-M2
evenGLO™
 RADIANT PATIO HEATER



⚠ DANGER

If you smell gas:

1. Shut off gas to heater.
2. Extinguish any open flame.
3. If odor continues, keep away from the heater and immediately call your gas supplier or fire department.

⚠ DANGER

Do not store or use gasoline or other flammable vapors and liquids in the vicinity of this or any other heater.
 A propane Cylinder not connected for use shall not be stored in the vicinity of this or any other heater.

⚠ WARNING

Improper installation, adjustment, alteration, service or maintenance can cause injury, death or property damage. Read the installation, operation and maintenance instructions thoroughly before installing or servicing this equipment.

⚠ WARNING

FOR OUTDOOR USE ONLY

⚠ IMPORTANT

Please retain these instructions for future reference.
 The installer must leave these instructions with the owner. Only those who are certified to do so should perform service on these heaters.

CALIFORNIA PROPOSITION 65

This heater, its related accessories and by-product of operation, contain chemicals known to the State of California to cause cancer and birth defects or other reproductive harm. For more information go to www.P65Warnings.ca.gov.

⚠ DANGER

CARBON MONOXIDE HAZARD



This heater can produce carbon monoxide which has no odor. Using it in an enclosed space can kill you.
 Never use this heater in an enclosed space such as a camper, tent or home.

Canada: 563 Barton St., Stoney Creek, Ontario L8E 5S1
www.irenergy.ca

Contents

CONTENTS	2
CAUTION AND GENERAL SAFETY	3
INTRODUCTION	5
APPLICABLE REGULATIONS	5
LOCATION PLANNING	6
GENERAL	6
SAFETY REQUIREMENTS.....	6
SPECIFICATIONS	7
EQUIPMENT DIMENSIONS.....	7
GAS AND POWER SPECIFICATIONS	7
PROPANE-GAS CYLINDER COMPATIBILITY.....	7
CLEARANCE TO COMBUSTIBLE MATERIALS	8
INSTALLATION INSTRUCTIONS	9
SHIPPING CRATE CONTENTS	9
HARDWARE KITS	10
ASSEMBLY	11
CONNECTING THE GAS SUPPLY.....	14
POSITION / MOVE HEATER	15
SECURE THE HEATER (OPTIONAL).....	16
TESTING / COMMISSIONING	17
LEAK TEST METHOD	17
ELECTRICAL WIRING AND BATTERY	18
<i>Wiring Diagram</i>	18
<i>Replacing the Battery</i>	18
OPERATING INSTRUCTIONS	19
LIGHTING.....	19
ADJUSTING TEMPERATURE	19
SHUTDOWN	19
MAINTENANCE & TROUBLESHOOTING	20
MAINTENANCE	20
CARE AND CLEANING	21
TROUBLESHOOTING	22
<i>No Gas Supply at Burner</i>	22
<i>No Spark</i>	22
<i>Flame Lights but Will Not Stay Lit</i>	22
REPLACEMENT PARTS	23
WARRANTY	25

CAUTION AND GENERAL SAFETY

CAUTION - FIRE OR BURN INJURY HAZARD

WARNING

Do not install or place on a table or on an inclined surface, make sure the installation surface is level before installing the heater.

- **Assembly & Installation will require the efforts of Two individuals, it is not recommended for only One Person to attempt complete assembly of the Heater.**
- At all times maintain clearance to combustible materials as further specified in this manual. Failure to do so can result in serious fire hazard.
- Never operate Heaters in atmosphere containing flammable vapours or combustible dusts.
- This Heater is equipped with an electronic ignition device. Do not attempt to light the burner by hand. Failure to comply can result in a serious fire and personal injury hazard.
- Heater surfaces, other than the obvious flame and emitter surfaces, attain elevated temperatures during operation. **Do not touch** the heater head during operation.
- Certain materials, when stored under this Heater are subjected to radiant heat can soften, distort or otherwise be damaged; special care should be taken of plastic materials
- **Children and adults should be alerted to the hazards of high surface temperatures and should stay away to avoid burns or clothing ignition.**
- **Young children should be supervised when they are in the area of the heater.** Playing or running around the heater should be strictly forbidden.
- **Clothing or other flammable materials should not be hung from the heater or placed on or near the heater.**
- **Any guard or other protective device removed for servicing the heater must be replaced prior to operating the heater.** Replacement pressure regulators and hose assemblies must be those specified by the manufacturer.
- **Installation and repair should be done by a qualified / certified service person. The heater should be inspected before use and at least annually by qualified service person.** (Service person must be 'Certified' by the local / national regulating body).
- Frequent cleaning may be required. It is imperative that Burners and circulating air passageways of the heater be kept clean of debris, dust and insects.
- Cleaning of the heater should only be done with non-combustible and non-corrosive cleaning agents. **DO NOT** alter the heater in any way; this includes shortening the pole or removing the Base Body cover or Top Reflector.
- **NEVER** paint the Burner, Emitter, Shield Support Arms or the Reflector.
- The visible portion of the Hose Assembly must be visually inspected before each use. If there is evidence of excessive abrasion or wear, or if the hose is damaged the hose assembly must be replaced prior to the heater being put into operation.

- This heater shall be used only in a well-ventilated area/space and shall not be used in a building, garages or any other enclosed area.
- Never go over connections looking for leaks with a lighted match, cigarette lighter, or any other flame.
- Perform the Leak Test before initial lighting and when connecting a new Propane-Gas Cylinder. A complete gas tightness check must be performed at the installation on site due to possible miss handling in shipment or excessive pressure being applied to the heater.
- Turn OFF Propane-Gas Cylinder when Heater is not in use.
- **Once the Heater has been shut-down, there shall be a 5-minute complete shutoff period before the Heater is re-lighted.**
- Ensure the Propane-Gas Cylinder is turned OFF and disconnected prior to moving the Heater.
- Storage of a Heater indoors is permissible only if the Propane-Gas Cylinder is disconnected and removed from the Heater.
- Use caution when moving the Heater, it may require two people to safely manoeuvre depending on the strength / size of the person(s). Handle ONLY the Pole or Base Body when moving the Heater, handling other components may result in damage and/or injury.

Propane-Gas Cylinder Caution and Safety

- Do not store a spare Propane gas cylinder under or near this heater.
- Never fill the Cylinder beyond 80 percent full.
- Keep Cylinders upright at all times, even during storage and transport.
- The pressure regulator and hose assembly **supplied** with the Heater must be used, or the replacement Hose Assembly **shall be** that specified by the manufacturer.
- Propane-Gas Cylinders must be stored outdoors in a well-ventilated area out of the reach of children. A disconnected cylinder must have dust caps tightly installed and must not be stored in a building, garage or any other enclosed area. Ensure the storage area meets all local fire & safety requirements.

INTRODUCTION

IR Energy is a company in the infrared heating industry founded on the principles of product quality and customer commitment.

Quality commitments are evidenced by superior design, a regard for design detail and an upgrade of materials wherever justifiable.

Customer commitment is apparent through our ready responses to market demands and a never-ending training and service support program for and through our distributor network.

IR Energy offers 25 years of experience in specialty infrared equipment design. **Series GA201-M2** models are infrared patio heaters that are easy to install and maintain, which were engineered with significant input from our customers. They are designed to provide economical operation and trouble-free service for years to come.

Important

These instructions, the layout drawing, local codes and ordinances, and applicable standards such as apply to gas piping and electrical wiring comprise the basic information needed to complete the installation and must be thoroughly understood along with general building codes before proceeding.

Only personnel who have been trained and understand all applicable codes should undertake the installation. IR Representatives are Factory Certified in the service and application of this equipment and can be called upon for helpful suggestions about installation.

APPLICABLE REGULATIONS

- Installation must comply with local building codes or, in their absence, the latest edition of the applicable national codes: USA - National Fuel Gas Code, ANSI Z 223.1 (NFPA 54), Canada - National Gas and Propane Installation Code, CSA B149.1.
- Use and Storage of this heater must comply with local codes or, in their absence, the latest edition of the applicable national codes: USA – Standard for Storage and Handling of Liquefied Petroleum Gases, Chapter 5 of ANSI/NFPA 58, Canada - Propane Storage and Handling Code, CSA-B149.2.
- This heater, when installed, must be electrically grounded in accordance with local codes or, in their absence, with the latest edition of the National Electrical Code, ANSI/NFPA 70, or the Canadian Electrical Code, CSA C22.1.
- For use ONLY with 20# Propane-Gas Cylinders (with a maximum capacity of 8kg [20lb]) constructed and marked in accordance with national codes: USA - U.S. Department of Transportation (“DOT” approved), Canada: Standard for Cylinders, Spheres and Tubes for Transportation of Dangerous Goods and Commission, CSA-B339 (“TC” approved).

Ensure Cylinders are:

- Provided with a permanent collar to protect the valve stem;
- Provided with a listed overfilling prevention device (OPD);
- Provided with a dust cap to cover the valve connection when not in use; (Only install the type of dust cap on the cylinder valve that is provided with the cylinder valve, other types of cap plugs may result in leakage of propane); and
- Provided with a cylinder connection device compatible with a QCC1 connection (Quick Connect Coupling).

LOCATION PLANNING

General

One Even-GLO heater, at high fire and in windless conditions, has a comfort radius of about twelve feet (24 ft. circle).

A series of heaters providing area heat should be placed about **14-20 feet apart**.

Wind protection has an important influence on the body's ability to retain radiant heat. Use natural or newly built wind barriers where possible, such as existing buildings, shrubbery or tree lines and fences.

WARNING

This heater is NOT approved for any indoor Residential application.

If in doubt of your application consult with your local fire marshal or gas authority having jurisdiction.

A Residential Dwelling is a housekeeping unit used or intended to be used as a domicile by one or more persons, containing cooking, eating, living, sleeping, and/or sanitary facilities. A Residential Dwelling does not include an attached and detached garage, workshop or outdoors.

The Heater may be installed with shelter no more inclusive than:

1. With walls on all sides, but with no overhead cover.
2. Within a partial enclosure which includes an overhead cover and no more than two side walls. These side walls may be parallel, as in a breezeway, or at right angles to each other.
3. Within a partial enclosure, which includes an overhead cover and three side walls, as long as 30 percent, or more, of the horizontal periphery of the enclosure is permanently open.

A patio that has been almost entirely closed in with a roof and windbreak walls or a tent may be considered an indoor location in some code authorities. Refer to the Natural Fuel Gas Code, ANSI Z.223.1 (NFPA 54) in the US and CSA B149.1 and B149.2 Installation Codes in Canada.

Safety Requirements

1. Never locate the heater directly below electrical lines, gas lines or sprinkler systems.

NOTE: Sprinkler head heat fuse link performance may alter with age.

2. Do not locate heater too close to vinyl or plastic wall coverings. These materials may discolour or soften well before they reach combustible limits.
3. The heater requires a minimum clearance from of combustible materials. See the Specifications / Details
4. Clearance to Combustible Materials information found in the Specifications / Details section.
5. Always allow room for removal of the Top Reflector and Burner head for maintenance purposes.
6. The heater aspirates (needs) air for combustion. Do not locate heater where there are severe draft conditions or airflow restrictions to the Burner head of the heater.

SPECIFICATIONS

Equipment Dimensions

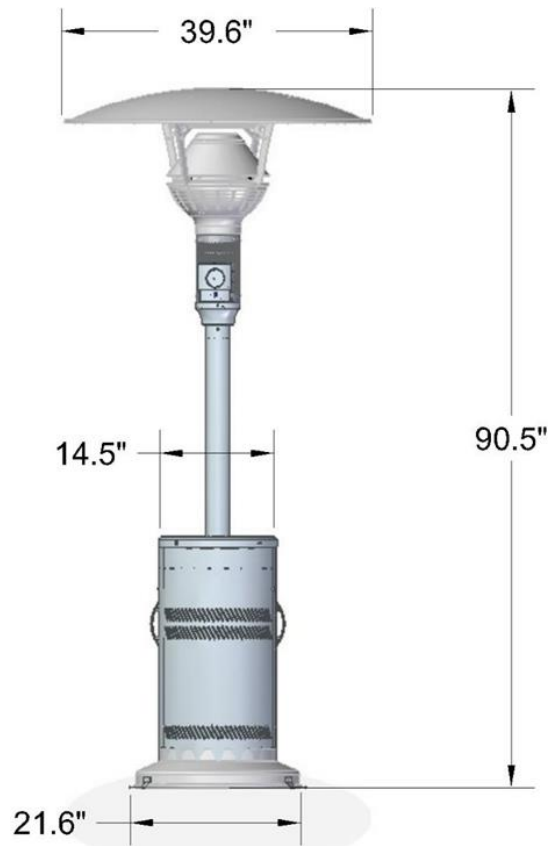

Figure 1: GA201-M2

Gas and Power Specifications

Maximum Fire Rate:	46,000 BTH/h
Gas Manifold Pressure	9.8" WC
Ignitor Electric Supply	One (1) "AA" Battery
Maximum Inlet Gas Supply Pressure:	250 psi
Weight without Propane Tank	140 lbs

Propane-Gas Cylinder Compatibility

To be used ONLY with 20lb Propane-Gas Cylinders with a maximum capacity of 8kg (20lb) which meet the criteria described in the Installation Codes section of this manual.

The Cylinder and its connector fittings must be maintained in good condition.

High Altitude Installation

When installing this heater over 4500 ft. above sea level in Canada, the heater must be properly de-rated and installed according to local codes. In the absence of local codes, the heater must be de-rated in accordance with the most recent CSA -B149 code. In the United States for installations over 2000ft above sea level the heater must be installed in accordance with the Current National Fuel Gas Code, ANSI Z223.1/NFPA 54(the heater shall be de-rated 4 percent for each 1000 ft of elevation above sea level). High altitude conversion kits are available, contact manufacturer for more details.

Clearance to Combustible Materials

The following clearance data is based on a maximum limit of 90°F (50°C) plus ambient temperature. Note with an ambient temperature of 70°F the surface temperatures at the clearance distances listed below could reach 160°F. Care should be taken with placement of plastic, or vinyl in the proximity of the heater as they tend to distort and soften at these temperatures.

Combustible materials are considered to be wood, compressed paper, plant fibres, plastic, Plexiglas or other materials capable of being ignited and burned. Such materials shall be considered combustible even through flame-proofed, fire-retardant treated or plastered.

Additional clearance may be required for glass, painted surfaces and other materials which may be damaged by radiant or convection heat.

NOTE: Some materials deteriorate or soften at sustained temperatures below 160°F.
Consult material manufacturer for recommendations

The Installer is responsible to ensure that building materials with a low heat tolerance which may degrade at higher temperatures are protected to prevent degradation.

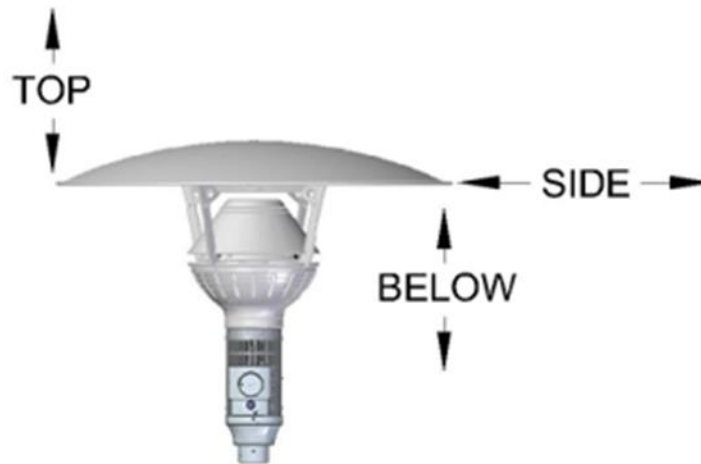
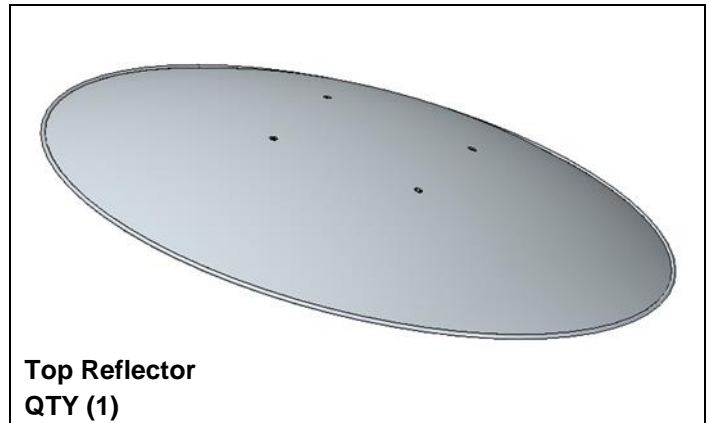
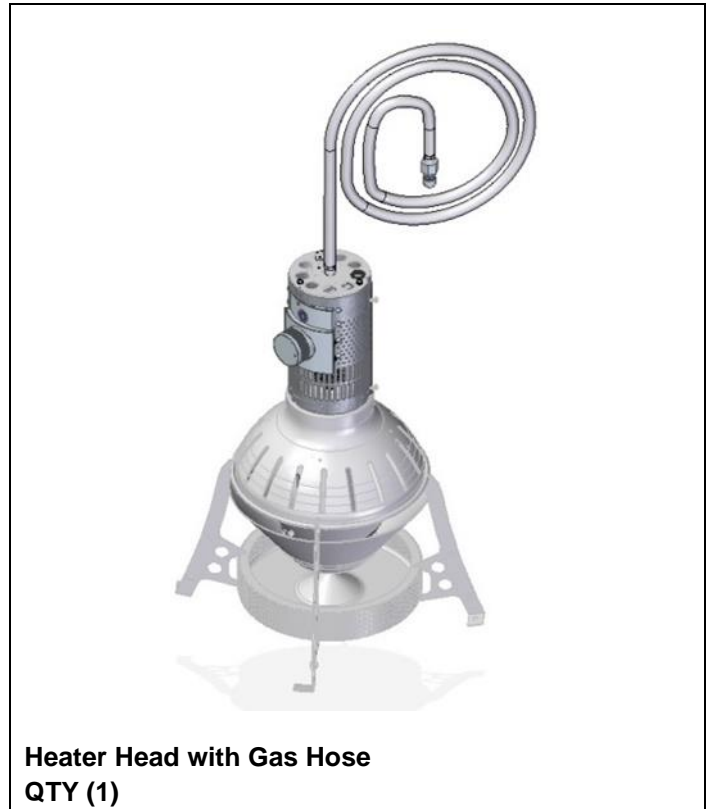
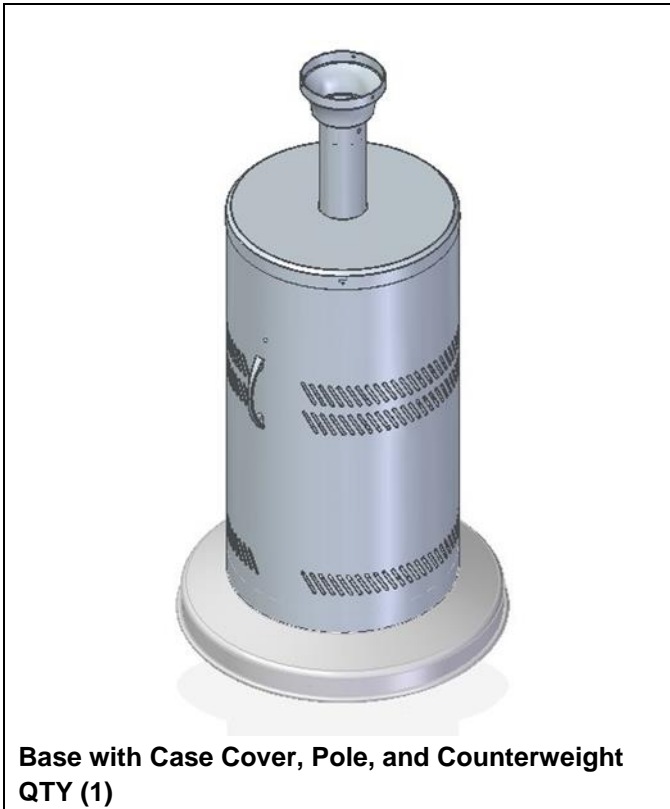

Figure 2: Clearance Dimensions

	TOP	SIDE	BELOW
GA201-M2	18"	22"	33"

INSTALLATION INSTRUCTIONS

Shipping Crate Contents



Hardware Kits

Base Body, Base Cover, Pole & Counterweight

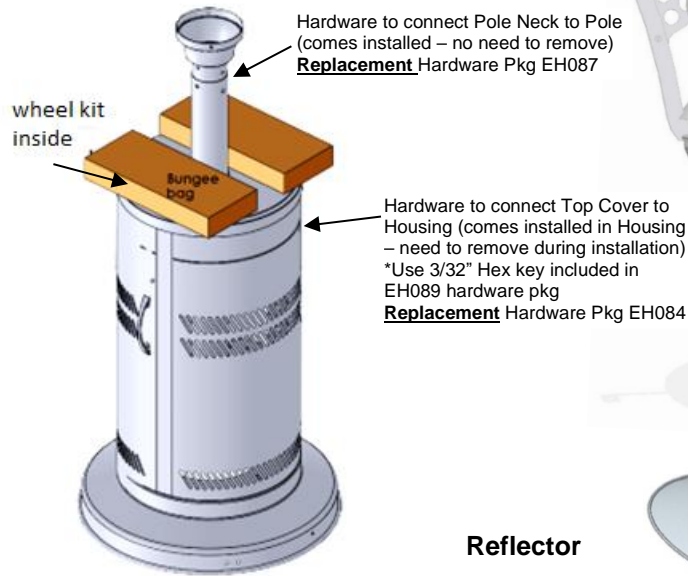

Heater Head Assembly

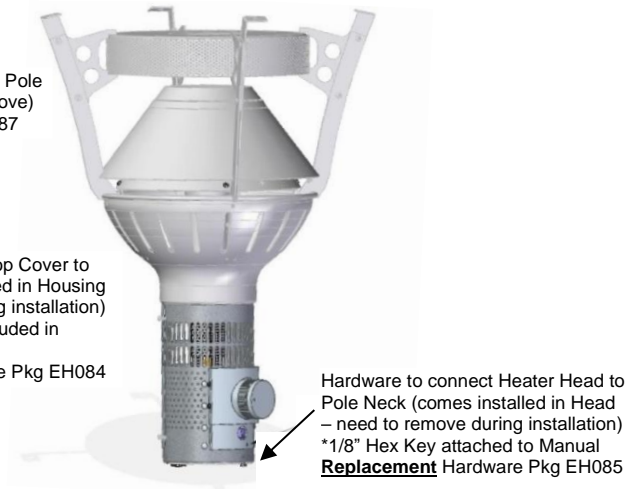

Reflector

Hardware to install Reflector included in Reflector Pkg.
Replacement Hardware Pkg EH001

Contents

Base Body:

- Bungee (EH044) – Used to Secure Supply Tank
- Wheel Kit (EH066) – Used to Mount Wheels
 - Wheel Assembly
 - 1/4"-20 x 1/2" S.S Button Socket (x2)
 - 1/4"-20 S.S Nuts (x2)
 - 1/4" S.S Lock Washer (x2)
- EH089 – Used to Secure Pole Assembly to Base Body
 - 3/8"-16 S.S Nylon Lock Nuts (x6)
 - 3/8" S.S Washers (x6)
 - 3/32" Allen Key
 - 1/8" Allen Key

Reflector:

- EH001 – Used to Secure Reflector to Support Arms
 - 1/4"-20 x 1/2" S.S Carriage Bolt (x4)
 - 1/4" S.S Washer (x4)
 - 1/4"-20 Acorn Nut (x4)

Note:

Hold Down Brackets to secure the heater to the ground are optional. If you require them for your installation, please contact your Representative for more details.

Assembly

1. Disassemble shipped parts and separate the hardware packages. Start with the heater base unit and the heater head assembly as shown in Figure 3.
2. Remove the screws from the burner head assembly (4 screws). Insert the gas supply hose into the pole neck. The hose will slide down the pole until the head assembly sits in the pole neck.

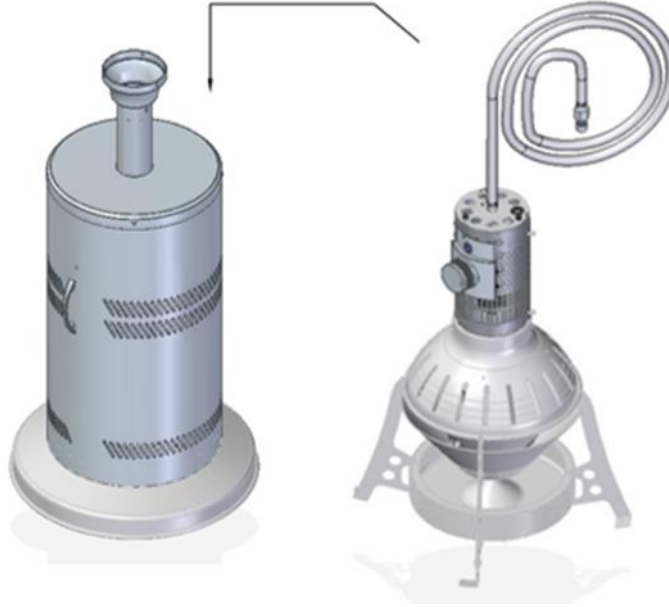

Figure 3: Heater Base and Heater Head Assemblies

3. Rotate the head assembly so the EvenGlo label on the heater head lines up with the EvenGlo label on the Main Base.



Figure 4: Location of Front Control Knob

4. Use the screws that were removed in Step 1 to secure the burner assembly to the pole neck assembly (4 screws).

5. Please refer to the illustrations below for clarity in this step:
 - a. Lift the pole assembly with the head attached, upwards. The housing top cover will come with it as there is packing underneath to hold the top cover in place while you lift the pole up.
 - b. Rotate the pole so that the mounting flanges almost line up with the cut-out on the base plates. Once the top mounting flange is above the surface, rotate the pole so the holes line up with the threaded bolts.
 - c. Lower the pole assembly onto the bolts so that they come through the holes on the mounting flange. Make sure the front of the heater is facing the Even-GLO faceplate on the front of the base.

Note: Housing cover is not shown below for ease of illustration.

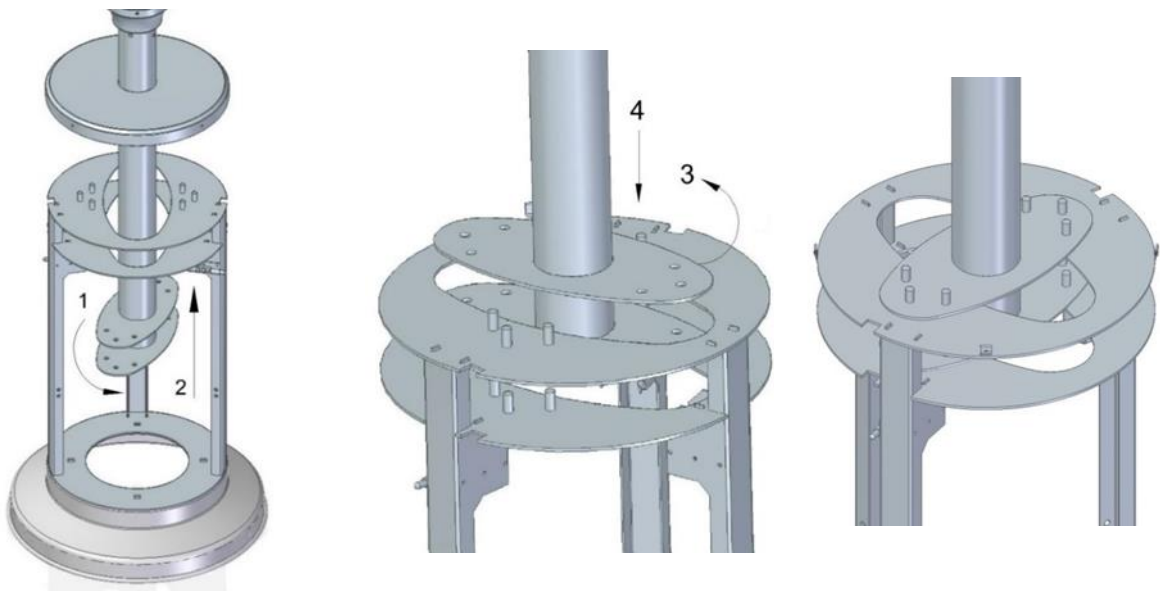

Figure 5: Pole and Housing Assembly

6. Take the contents out of hardware bag EH089. Slip the washers on the threaded bolts (6 washers). Secure the pole assembly by threading the lock nuts (6 lock nuts) onto the threaded bolts and tighten with a wrench or socket.
7. Remove the 4 screws in the Heater Base housing and use them to attach the housing top cover. Carefully take off the packaging holding the housing top cover up the pole. Slide the top cover down the pole, covering the pole mounting flange and hardware. Use the 3/32" allen key to tighten, located in hardware bag EH089.
8. Locate the Wheel Kit. Open the packaging and take the wheel assembly and the hardware provided out. Locate the two mounting holes on the Main Base. Line up the wheel assembly as shown in Figure 6 below. Insert both bolts into the matching set of mounting holes. Tip the heater slightly to be able to thread on the nylon nuts provided underneath the main base. Tighten the nuts until the wheel assembly is secure.

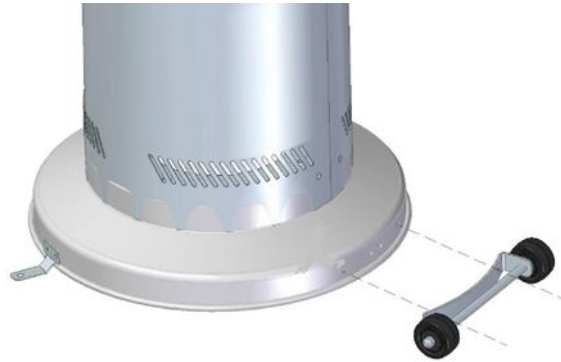

Figure 6: Attach Wheel Assembly to Main Base

9. Locate the reflector and hardware bag EH001. Install the Top Reflector on to the Shield Support Arms of the heater using the carriage bolts (4) with nuts provided. Insert the bolts up through the shield support arms and then through the top reflector. Secure each bolt on top of the reflector.

Note: Make sure to remove (or peel off) the plastic covering on the reflector before assembly.



Figure 7: Attach Top Reflector to Shield Support Arms

10. Your patio heater is now assembled and ready to connect to your Propane Gas Supply Cylinder.

WARNING

This Heater is equipped with a tilt / tip switch for your safety. This heater will shut the gas valve if it is tipped or tilted.

This Heater will not operate at an inclined position. Ensure the heater is in the upright position and should never be positioned on an incline.

Connecting the Gas Supply

WARNING

For use ONLY with 20# Propane-Gas Cylinders (with a maximum capacity of 8kg [20lb]) constructed and marked in accordance with national codes: U.S. Department of Transportation (“DOT” approved) in the USA, and Standard for Cylinders, Spheres and Tubes for Transportation of Dangerous Goods and Commission, CAN/CSA-B339 (“TC” approved) in Canada.

1. Lift the Main Housing Cover up by the handles until the bottom lip is clear of the 2 spring latches as shown below:

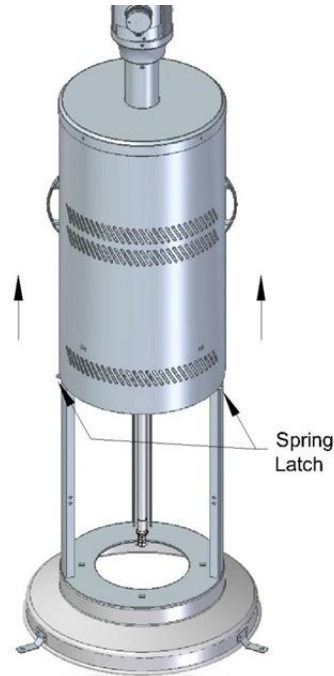

Figure 8: Lift Main Housing Cover

2. Secure the Propane-Gas cylinder to the Base using the Bungee cord. Hook one side of the Bungee cord to the mounting holes on either the right side or the left side, as shown in Figure 9. Make sure the Propane-Gas cylinder is in the upright position. Feed bungee through the handle of the Propane cylinder, then hook the bungee on the other set of securing holes.

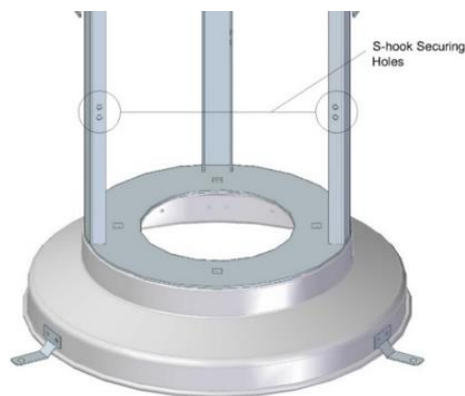

Figure 9: Secure Propane Cylinder with Mounting Holes and Bungee Cord

3. Locate the regulator assembly. Look over the assembly to make sure no damage has occurred during shipping or handling. Attach the regulator assembly to the male quick connect on the fuel supply hose as shown in Figure 10.

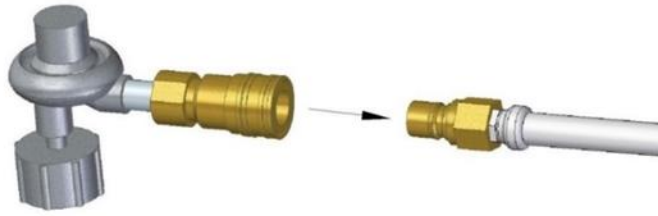

Figure 10: Connect Regulator Assembly to Fuel Supply Hose

4. Secure the Gas Hose Regulator onto the Propane-Gas cylinder valve by turning the Regulator clockwise until tight. Push the 2 spring latches that are holding the main housing cover in place inwards, one hand holding the bottom lip of the main housing cover and the other one pushing the latches one at a time. Be careful of the bottom edge of the main housing as it is sharp.



Figure 11: Secure Gas Regulator to Propane Cylinder

CAUTION

Before using the patio heater:

- Perform a leak test to make sure the regulator connection does not have leaks.
- Move heater to desired location.
- Secure the Base Body to the floor (optional).

Position / Move Heater

1. Ensure the Propane-gas Cylinder is turned **OFF**, secured and disconnected from the Gas Hose prior to moving the Heater.
2. Ensure the wheels are properly connected to the base body (refer to installation step 8).

3. **Move the Heater by handling ONLY the Pole or the Base Body.** It may take two people to manoeuvre the Heater safely depending on the size / strength of the person(s).
4. Tip the Heater backwards at an angle to / overtop of the wheels until the Base no longer touches the ground. Wheel / Roll the heater to the desired location and return base to the ground. Ensure the heater is on level ground and stable in new location.
5. If the heater is going to be operated at the new location, the "Testing / Commissioning" procedure must be completed.

Secure the Heater (Optional)

1. Ensure that the Hold Down Brackets are properly installed as described in Installation Step 8.
2. The type of Foundation Fastener required depends on the type of Floor / Ground that the Heater is located on. Prepare the Floor / Ground as detailed in Table A at all three bracket locations. (Ensure that alignment with the connecting hole(s) of the Base Bracket is maintained)

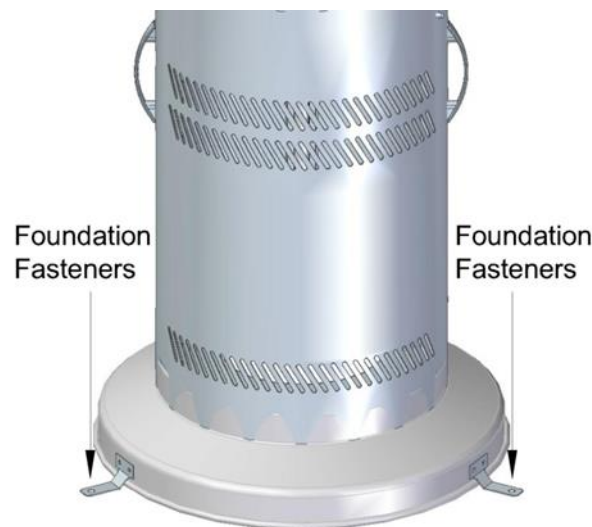

Table A: Methods for Securing Heater to Floor / Ground

Floor / Ground Type	Foundation Fastener Type & Size	Mounting Method Summary	Floor / Ground Preparation
Concrete	Concrete Anchor Ø5/16" x 2 1/2"	Place Anchors into pilot holes aligned with Base Brackets - tap / hammer lightly, screw fastener into anchor	Drill 3 - Pilot Holes Pilot hole drill size: Concrete = 9/16"
Wood Deck	Wood Screw #10 x 1 1/2"	Secure using Wood Screws in pilot holes aligned with Base Brackets	Drill 3 - Pilot Holes Pilot hole drill size: Hardwood = 7/64" Softwood = 3/32"

TESTING / COMMISSIONING

Leak Test Method

WARNING

Never go over connections looking for leaks with a lighted match, cigarette lighter, or any other flame.

Perform the leak test before initial lighting and when connecting a new Propane-Gas Cylinder. A complete gas tightness check must be performed at the installation on site due to possible mishandling in shipment or excessive pressure being applied to the heater.

1. Make up a dish of soap and water solution of one-part liquid detergent and one-part water.
2. Spread the soap and water solution over the hose connections with a spray bottle, a small paintbrush or rag.
3. With the heater shut OFF, turn the cylinder valve ON. Check the connections at the Propane-Gas cylinder.
4. Take off the Housing Service Cover (see Figure 12). Check the gas line attachment points to the valve.
5. Any leaks will result in bubbles forming in the solution. If a leak is detected, shut OFF the cylinder valve.
6. Repair any leak by tightening leaking parts (Replacement Gas Hose Assembly shall be as specified by the manufacturer).
7. Repeat steps 1, 2, and 3 until no leaks are detected at all hose connection locations as shown in Figure 12.

If you cannot stop the leaks, shut OFF the supply valve on the Propane-gas Cylinder and disconnect the cylinder from the heater. Please the heater OUT OF SERVICE and consult a certified service person.

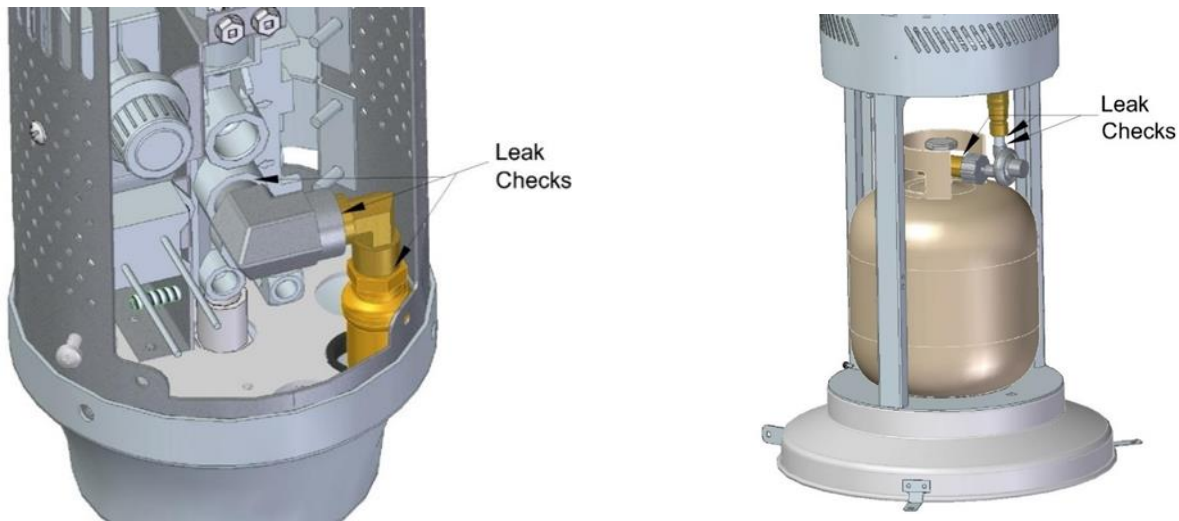

Figure 12: Leak Check Points

After passing the Leak Test your patio heater is now ready for use.

CAUTION

**Heater will produce smoke the first time it is lit. This is normal.
DO NOT light the heater in an enclosed area.
Make sure all protective plastic has been removed from all surfaces before lighting.**

ELECTRICAL WIRING AND BATTERY

Wiring Diagram

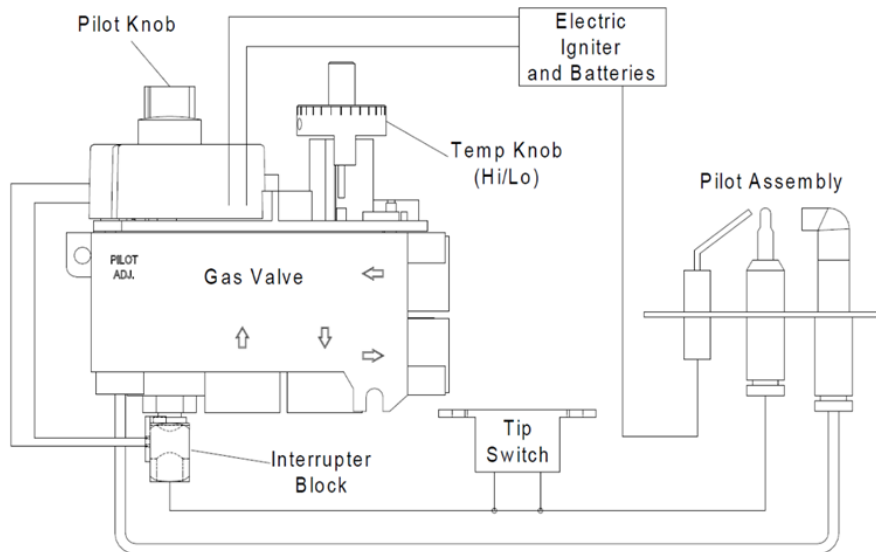

Figure 13: GA201-M2 Wiring Diagram

Replacing the Battery

1. Remove the Housing Service Cover to access the Ignitor Module Knob.
2. Turn the ignitor module knob counter-clockwise to unscrew it.
3. Pull out the battery while taking note of the polarity orientation (+ / -).
4. Replace battery and screw knob back into place.
5. Test spark by going to the front of the heater and pressing Ignition Knob in the Pilot position.
6. Replace the Housing Service Cover.

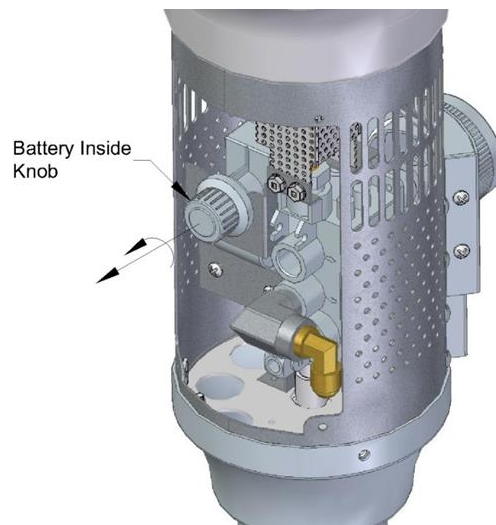

Figure 14: Replacing the Battery

OPERATING INSTRUCTIONS

Lighting

1. Open the propane cylinder valve.
2. Push and turn the ignition knob counter-clockwise from the OFF position to the PILOT position (lightening symbol). To start the gas flow and sparking, push the knob inwards. **Keep pressing until the pilot is lit and stays lit (for approximately 30-45 seconds to heat up the thermocouple) and then release the pressure from the knob.** If you have warmed up the thermocouple enough, when you release the pressure from the ignition knob, the main burner will automatically light. If it does not, try igniting the pilot again, but waiting a longer interval before releasing the knob.

Note: When using the heater with a fresh fuel supply, pilot may take some time to light because the light needs to purge all the air out of the line first.

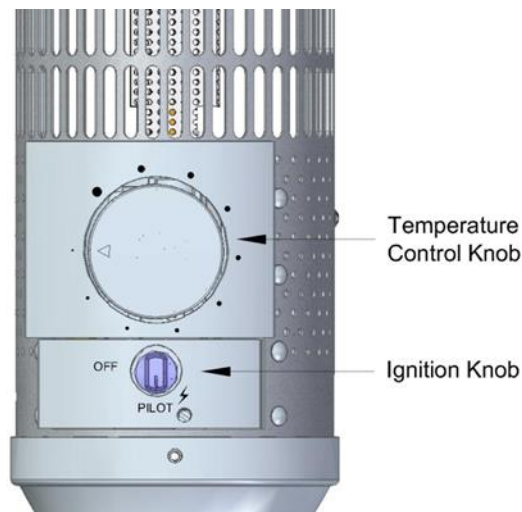

Figure 15: Location of Ignition Knob and Temperature Control Knob

CAUTION

Heater will produce smoke the first time it is lit. This is normal.
DO NOT light the heater in an enclosed area.

Adjusting Temperature

Adjust the heat output by rotating the Temperature Control Knob counter-clockwise to increase the output, clockwise to lower the output.

Shutdown

1. Turn the ignition knob clockwise into the OFF position to turn off the gas flow and extinguish the burner flame.
2. Turn propane cylinder valve clockwise to OFF position when heater is not in use.

WARNING

Improper Lighting, Shutting Down can cause injury, death, or property damage. Read the Lighting and Shutting Down instructions thoroughly before operating or servicing this equipment.

Maintenance & Troubleshooting

Maintenance

CAUTION

- Always follow all Caution and General Safety rules before / during use.
- Before performing ANY service to the heater, shut off the gas supply, disconnect the regulator from the Propane-Gas Cylinder and remove the battery from the ignitor module.
- If any maintenance issues are found place the heater OUT OF SERVICE until it has been repaired by a certified service person. Use only manufacturer recommended replacement parts.

Daily Inspections:

1. Keep the heater area clean and free from combustible materials, gasoline and other flammable vapors and liquids.
2. The visible portion of the Gas Hose must be visually inspected before each use. If there is evidence of excessive abrasion or wear, or if the hose is damaged the hose assembly must be replaced prior to the heater being put into operation.
3. Keep the ventilation opening(s) of the cylinder enclosure free and clear from debris and cobwebs.
4. Visually check the Burner flame pattern during use. A "Proper Flame" should resemble image on Figure 16.
5. If at any time flames extend beyond the emitter surface (see image in Figure 17 "Improper Flame") or black soot is found on the inside of the reflector TURN OFF the heater immediately and place OUT OF SERVICE until repairs are made.
6. Clean the heater if necessary with non-combustible and non-corrosive cleaning agents. Ensure control compartment (ignition module), burners & circulating air passageways are kept clean of dust, insects, cobwebs and other debris

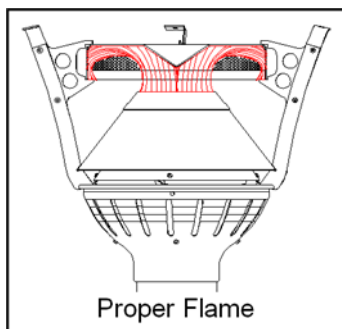

Figure 16: Proper Flame Pattern

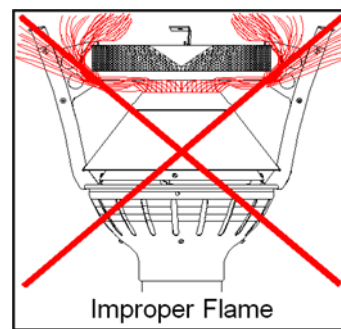

Figure 17: Improper Flame Pattern

Annual Inspections:

1. Inspect and Leak Test entire Gas Hose Assembly for damage, excessive abrasion, wear and leaks:
 - a. Ensure burner is cool to touch and supported while disassembling.
 - b. Disassemble the Burner from the Pole by removing the three (3) screws in the Pole Neck.
 - c. Remove the Gas Hose Assembly from the Pole to inspect and Leak Test the entire hose and all connections. Repair / replace as required.
2. Check condition of the Burner, especially the integrity of the flame screen.
3. Inspect condition of spark and sense electrode. Check for cracks in ceramic insulators or excessive corrosion.
4. Inspect condition of high-tension lead to spark rod.

Care and Cleaning

Cleaning Stainless Steel Patio Heaters

Stainless steel is protected from corrosion by a thin layer of chromium oxide. This happens when oxygen from the atmosphere (air) combines with the chromium in the stainless steel to form this layer of chromium oxide. This passive film or layer protects the stainless steel from further corrosion.

Stainless steel is easily cleaned by many different methods.

General Rules for Cleaning Stainless Steel:

1. Handle stainless steel with clean gloves or cloths to guard against fingerprints.
2. Avoid the use of oily rags or greasy cloths when wiping the surface.
3. Where possible, after cleaning, thoroughly rinse with water.
4. Cleaning with detergents containing chloride must be AVOIDED.
5. Rubbing or wiping should be in the direction of the polish lines NOT against them.
6. DO NOT use solvents in closed spaces or while the heater is running or smoking.

Methods to clean Surface Contamination

Dirt

Dirt and soil can consist of accumulated dust and a variety of contaminants that come from many sources, ranging from the wind to everyday use. Some may be easily removed, while others may require specific cleaners.

- Frequently, warm water with or without a gentle detergent is sufficient.
- Next in order, mild non-scratching abrasive powders such as typical household cleaners. These can be used with warm water, bristle brushes, sponges, or clean cloths. DO NOT USE ordinary carbon steel brushes or steel wool.
- Next in order, for more aggressive cleaning, a small amount of vinegar can be added to the scouring powder.

Cleaning should always be followed by rinsing with CLEAN HOT WATER and drying with clean towels.

Fingerprints and Stains

Fingerprints and mild stains resulting from normal use are the most common surface contaminants. These do not affect the corrosion resistance and are easy to remove.

- Can be removed using a Glass Cleaner.
- Or gentle rubbing with a paste of Soda Ash (sodium carbonate) and water applied with a soft cloth.

Cleaning should always be followed by rinsing with CLEAN HOT WATER and drying with clean towels.

Oil and Grease

Oil and grease may carry grit, dust and sand which produce surface soiling, so periodic removal is necessary.

- Can be removed using soap or detergent and water or a combination of detergent and water plus a solvent. Non-halogenated solvents, such as Acetone, Methyl Alcohol, and Ethyl Alcohol work well. The preferred solvent is one that does not contain Chlorine.

Cleaning should always be followed by rinsing with CLEAN HOT WATER and drying with clean towels.

Preventative Care and Maintenance

EH105 – Custom Dome Cover – A custom protective cover designed to increase the life of your EvenGlo. Item is not included with purchase, please contact your Representative for further details.

Troubleshooting

No Gas Supply at Burner

- Ensure manual shut off valve is in proper position.
- Ensure there is pressure and flow at inlet to gas valve.
- Ensure propane gas cylinder has fuel in it.
- When using the heater with a fresh fuel supply, pilot may take some time to light because the light needs to purge all the air out of the line first.

No Spark

- Ensure the battery in ignition module is operating.
- Ensure spark electrode assembly is grounded and there are no cracks in the ceramic insulator.
- Ensure the spark gap between the pilot and spark ignitor is 1/8"-3/16" (3-4.5mm) as per picture below:

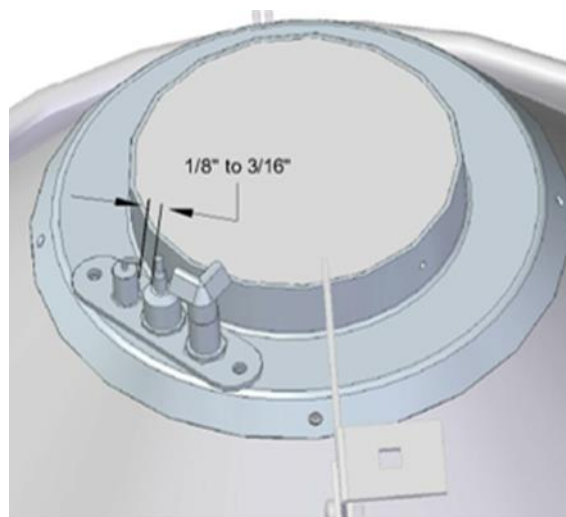

Figure 18: Proper Spark Gap

Flame Lights but Will Not Stay Lit

- Be sure to hold pilot knob in for one minute or longer to allow sensor to get hot.
- Ensure there is no overpowering wind.
- Ensure sense electrode is not corroded, is not grounded, and does not have a cracked insulator.

REPLACEMENT PARTS

Part Reference

Item	Description	Part No.	Qty
1	Pole Neck	RP-ES170*	1
2	Housing Top Cover	RP-ES171*	1
3	Pole Assembly	RP-ES172*	1
4	Emitter	RP-ES011	1
5	Knob	RP-EH016	1
6	Handle	RP-EH046	2
7	Wheel Assembly	RP-EH066	1
8	Burner Housing Assembly	ES185*	1
9	Arm Assembly w/Shield Support	RP-ES145S	4
10	Main Tank Housing	RP-ES161*	1
11	Main Base	RP-ES168*	1
12	Tip Switch	RP-EE034	1
13	Electronic Igniter	RP-EE028	1
14	Gas Valve	RP-EG036	1
15	Current Interrupter	RP-EG038	1
16	Pilot Assembly NG (w/ Thermocouple, Pilot Tube, & Hardware)	RP-EG067	1
	Pilot Assembly LPG (w/ Thermocouple, Pilot Tube, & Hardware)	RP-EG068	1
17	Thermocouple	RP-EE038	1
18	Breakaway Pilot Nut	KG015	2
19	Pilot Tube S/S	RP-EG042	1
20	Regulator Assembly	RP-EG056	1
21	Top Refl. Pkg w/ Hardware	ES041	1
22	Outer Shield	RP-ES233A	1

IR Energy reserves the right to make improvements to its product line without notice. Every part is replaceable; if the part is not listed above, please contact your IR Energy Rep for part information.

NOTE:

For parts with "*" suffix add S, BLJ, or BRM to the end of the part numbers for desired finish.

"S" = Stainless Steel
 "BLJ" = Jet Black
 "BRM" = Medium Bronze

Part Reference

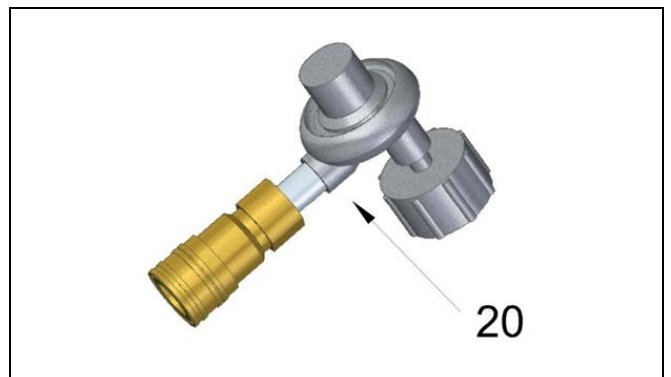
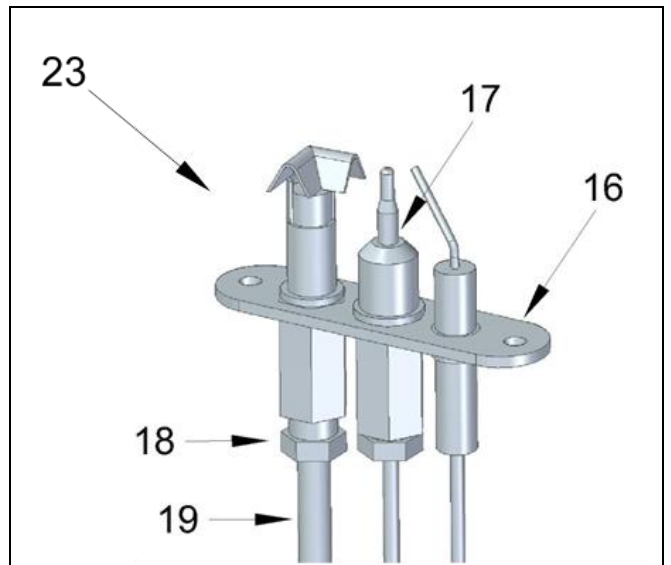
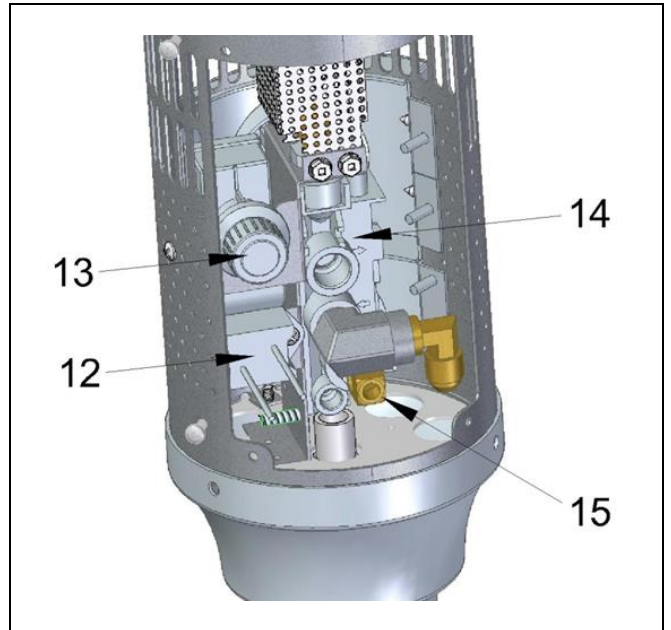
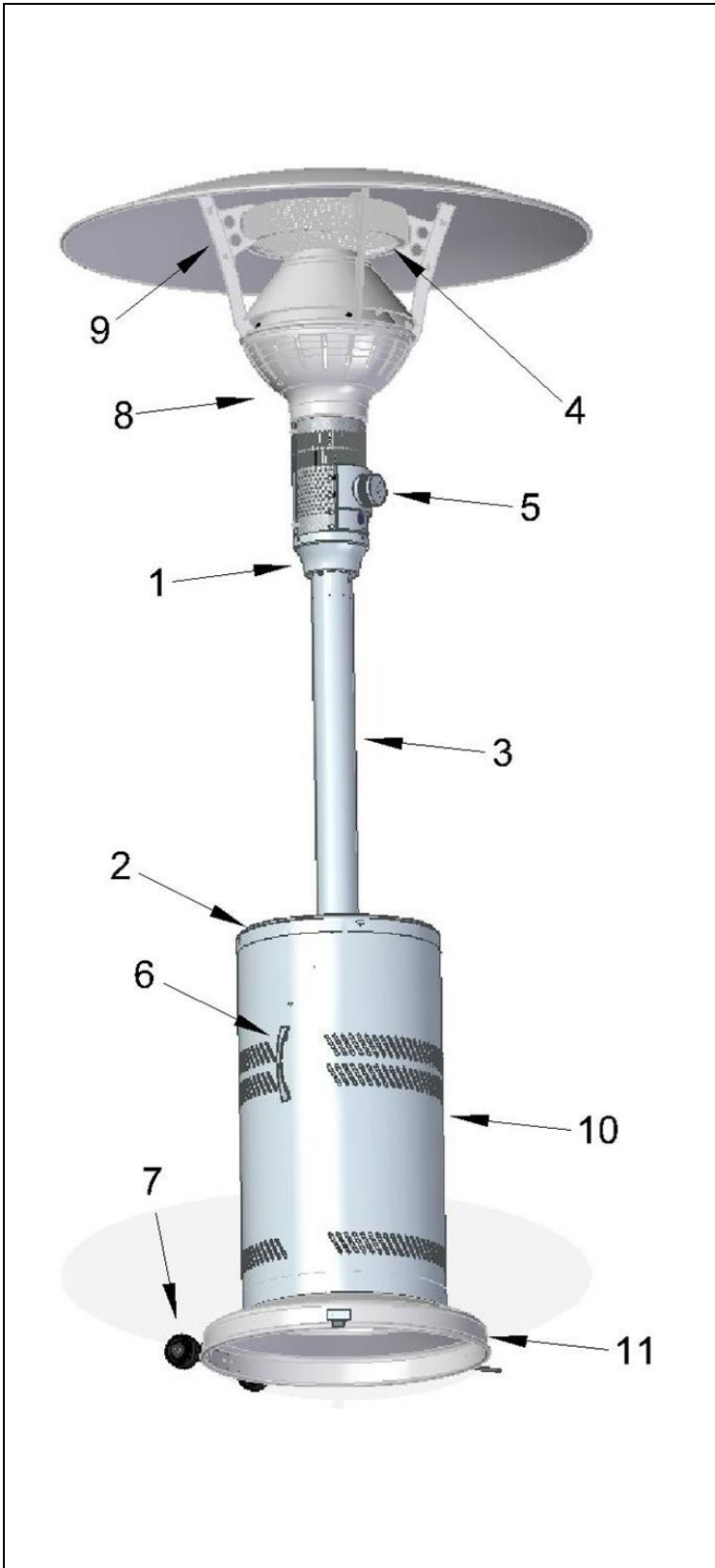

WARRANTY

SERIES GA201-M2 INFRARED OUTDOOR PATIO HEATER WARRANTY

THE MANUFACTURER WARRANTS TO THE ORIGINAL OWNER THAT THE EMITTER OF THE PRODUCT WILL BE FREE OF DEFECTS IN MATERIAL AND WORKMANSHIP FOR A PERIOD OF 3 YEARS FROM THE DATE OF PURCHASE. ALL OTHER PARTS OF THE PRODUCT WILL HAVE A WARRANTY PERIOD OF 1 YEAR.

The Manufacturer's obligation under this warranty is limited to repair or replacement; FOB its facility, of the defective part. In the case of replacement parts the warranty period shall be the longer of the original warranty or a period of 12 months from the date of purchase. In no event shall the Manufacturer be liable for incidental expense or consequential damages of any kind.

This warranty does not cover any shipping, installation or other costs incurred in the repair or replacement of the product. No materials will be accepted for return without authorization.

This warranty will not apply if, in the judgment of the Manufacturer, the equipment has been improperly installed, maintained, unreasonably used, damaged or modified.

This warranty will not apply to damage to the product when used in corrosive atmospheres. The warranty provides protection against rust-through of parts that render the product inoperative. It does not cover occasional surface rust or staining due to environmental conditions. No person is authorized to assume for the Manufacturer any other warranty, obligation or liability.

THE REMEDIES PROVIDED FOR IN THE ABOVE EXPRESS WARRANTIES ARE THE SOLE AND EXCLUSIVE REMEDIES. NO OTHER EXPRESS OR IMPLIED WARRANTIES ARE MADE INCLUDING, BUT NOT LIMITED TO, ANY IMPLIED WARRANTY OF MERCHANTABILITY OR FITNESS FOR A PARTICULAR USE OR PURPOSE.

Manufacturer Contact Information:



563 Barton Street
Stoney Creek, ON
L8E 5S1
Canada

www.irenergy.ca