

## DIMENSIONI D'INGOMBRO - OVERALL DIMENSIONS

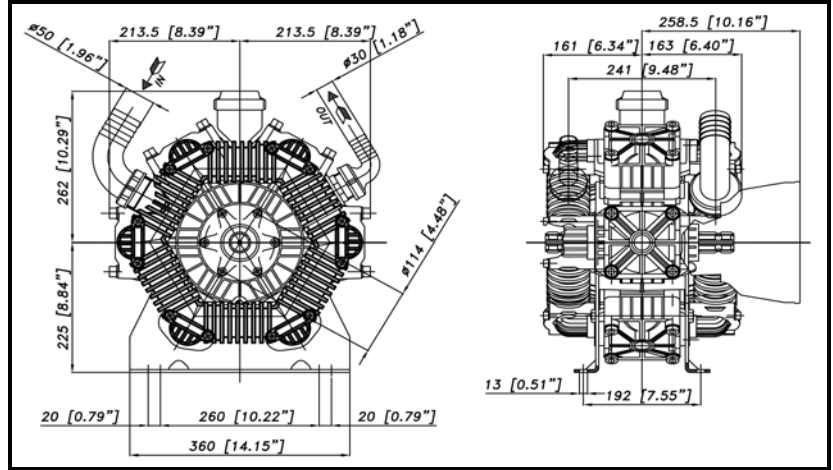

## ALBERO POMPA - PUMP SHAFT

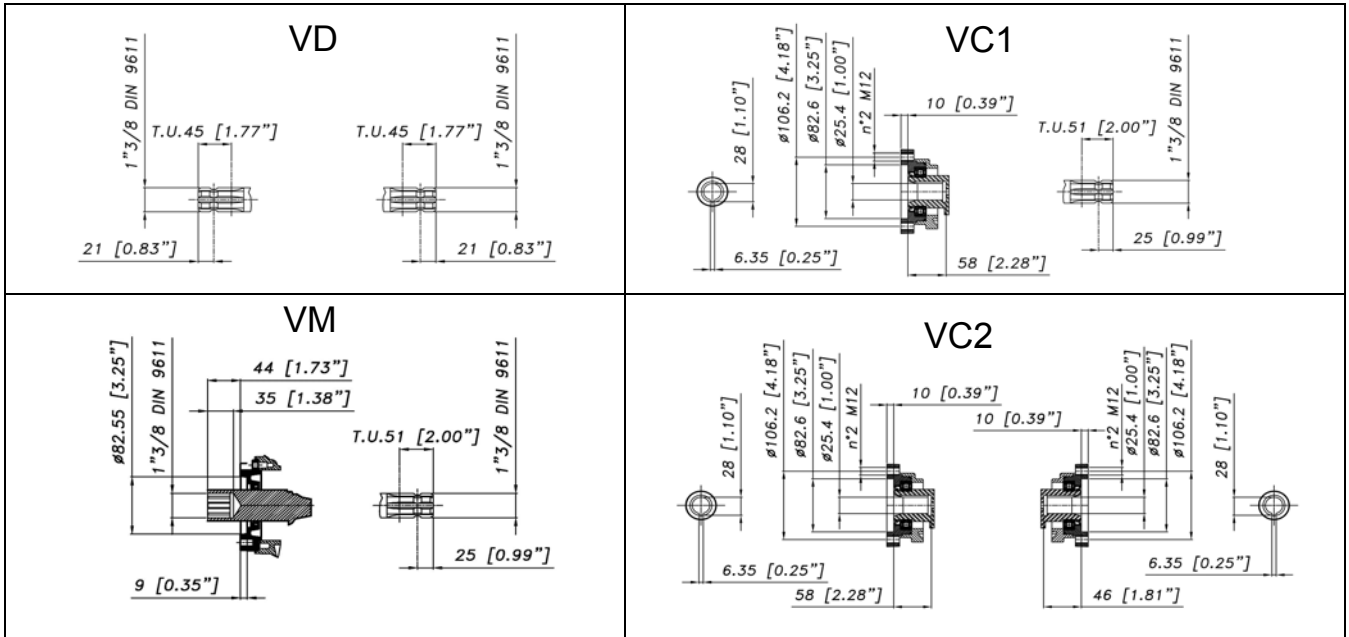

COPPIA DI SERRAGGIO - TORQUE CHART				
CODICE - CODE	Q.TY	POS	N-m	Lbr.ft
62.9811.97.3	6	47	25	18,4
85.2576.00.2	2	15	5 (LOXEAL 24-18)	3,7 (LOXEAL 24-18)
86.2168.00.2	2	45	5	3,7
86.3694.50.2	1	25	40	29,5
86.2562.50.2	6	32	22	16,3
86.2682.50.2	2	34	22	16,3
86.3044.50.2	24	40	10	7,4
86.4139.00.2	2	28	40	29,5
86.4068.00.2	24	8	40	29,5

Tolleranza di serraggio: 0/-10%  
Tolerance on torque value:

INFORMAZIONI UTILI USEFUL INFORMATION				
LUBRIFICANTE- LUBRICANT: OLIO MOTORE O SEMIIDRAULICO SAE 30 MOTOR OIL OR SEMI-HYDRAULIC OIL SAE 30				
PRESSIONE ACCUMULATORE ACCUMULATOR PRESSURE				
PRESSIONE DI LAVORO - OPERATING PRESSURE	2 ÷ 5	5÷10	10 ÷ 20	20 ÷ 50
ACCUMULATORE ACCUMULATOR	/	/	/	/

## KIT MEMBRANE - DIAPHRAGMS KIT

KIT	14.9877.97.3	BUNA - N		14.9878.97.3	DESMOPAN		14.9886.97.3	VITON				14.9882.97.3	PENTAX	
		1	3		1	3		1	3	5	14		1	3
POSIZIONE ESPLOSO POSITION NUMBER														
QUANTITA' NEL KIT QUANTITIES INCLUDED	6	12		6	12			6	12	6	12	6	12	

## KIT POMPA/KIT VALVOLE - PUMP KIT/VALVES KIT

KIT	14.9883.97.3	KIT POMPA VD VD PUMP KIT				14.9884.97.3	KIT POMPA VC1/VM VC1/VM PUMP KIT					14.9885.97.3	KIT POMPA VC2 VC2 PUMP KIT			14.9875.97.3	VALVOLE VALVES			14.9876.97.3	VALVOLE VALVES INDX					
		18	5	14	3		30	5	14	3	30		18	69	5		14	3	30		69	74	2	3	5	2
POSIZIONE ESPLOSO POSITION NUMBER																										
QUANTITA' NEL KIT QUANTITIES INCLUDED	2	6	12	12	1	6	12	12	1	1	1	6	12	12	1	1	1	12	12	6	12	12	6	12	12	6

# POLY 2250 - 2260 VD (1"3/8 M-M)

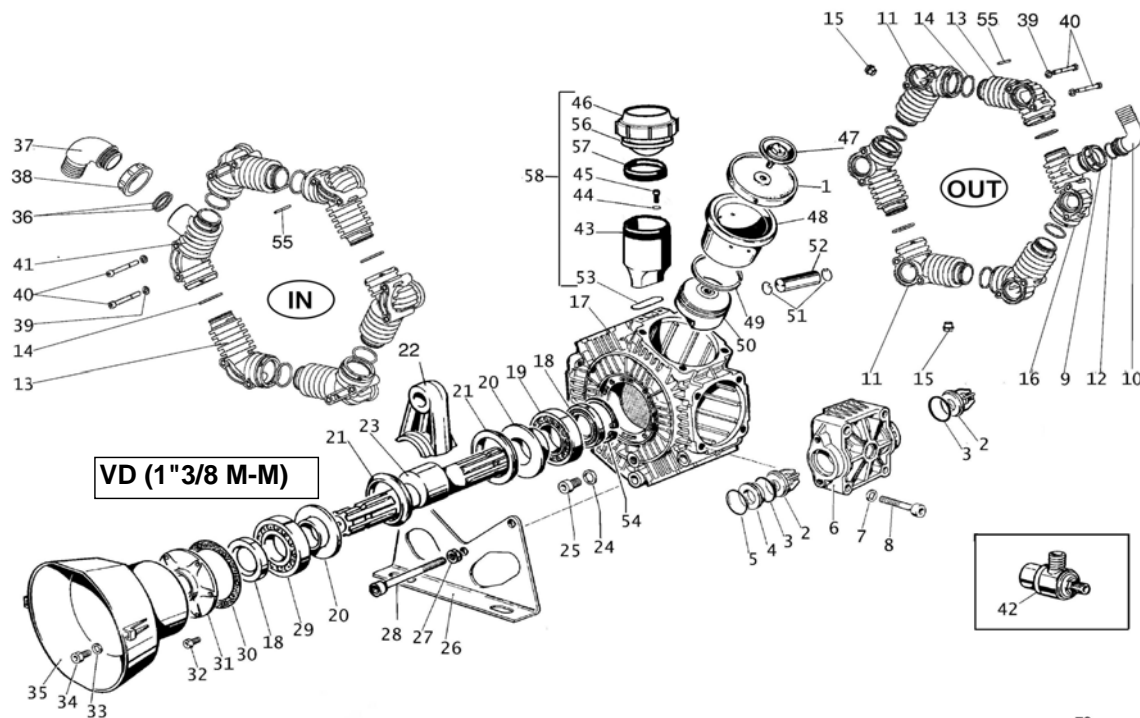

## VERSIONI

### VM (1"3/8 M-F)

### VC1 (1"3/8 - D.1" M-F)

### VC2 (D.1" F-F)

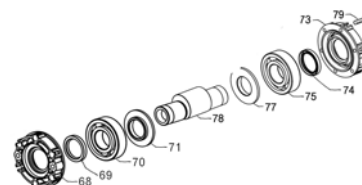
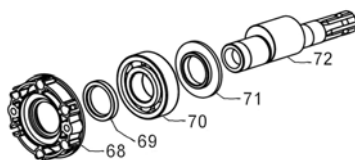
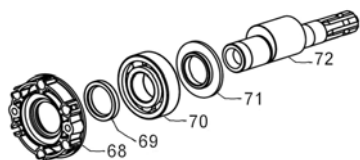

POS.	CODICE PART NO. REF.	DENOMINAZIONE - DESCRIPTION - DESCRIPTION	Q.TY	POS.	CODICE PART NO. REF.	DENOMINAZIONE - DESCRIPTION - DESCRIPTION	Q.TY
1	62.0040.00.2	DESOPAN PISTON DIAPHRAGM	6	33	84.3696.00.2	WASHER DIA.8,4x18x2 (OPTIONAL)	2
1	62.0040.31.2	BUNA-N PISTON DIAPHRAGM (optional)	6	34	86.2682.50.2	SCREW M8x25 UNI5931 (OPTIONAL)	2
1	62.0040.33.2	VITON PISTON DIAPHRAGM (optional)	6	35	31.1482.32.2	PLAIN SAFETY CONE L=182 (OPTIONAL)	1
2	28.9809.97.3	S.S. VALVE ASSY	12	35	31.1468.32.2	PLAIN SAFETY CONE L=135 (OPTIONAL)	1
3	80.3314.00.2	O-RING 4,5x40	12	36	80.3209.10.2	O-RING 2,62x40,95	2
3	80.3314.50.2	O-RING 4,5x40 (KIT VITON)	12	37	84.0610.00.2	90° ELBOW CONNECTOR DIA.50-1,96"	1
4	28.0229.32.2	VALVE ASSY SPACER	6	37	84.1643.00.2	STRAIGHT CONNECTOR DIA.50-1,96" (optional)	1
5	80.3209.40.2	O-RING 2,62x44,12	6	38	82.0120.00.2	WING NUT G.2"	1
5	80.3209.50.2	O-RING 2,62x44,12 (KIT VITON)	6	39	84.3697.00.2	WASHER DIA.8,4x18x2	24
6	62.0025.32.2	HEAD	6	40	86.3044.50.2	SCREW M8x90 UNI5931	24
7	84.3844.50.2	WASHER DIA.12,2x21x2,5	24	41	14.0032.32.2	PIPE MANIFOLD G 2"	1
8	86.4068.00.2	SCREW M12x75 UNI5931	24	42	24.3016.97.3	SAFETY VALVE 15 bar (OPTIONAL)	1
9	82.0070.00.2	WING NUT G.1"1/2	1	43	14.0117.32.2	BOWL OIL FILLER	1
10	84.0561.00.2	90° ELBOW CONNECTOR DIA.30-1,18"	1	44	84.3585.00.2	WASHER D.6,4X12,5X1,6	2
10	84.0566.00.2	90° ELBOW CONNECTOR DIA.32-1,25" (opt.)	1	45	86.2168.00.2	SCREW M6x22 UNI5931	2
10	84.0570.00.2	90° ELBOW CONNECTOR DIA.35-1,37" (opt.)	1	46	28.0144.32.2	OIL FILLER CAP	1
10	84.0571.00.2	90° ELBOW CONNECTOR DIA.38-1,49" (opt.)	1	47	62.9811.97.3	KIT SCREW/DISK INOX	6
10	84.0591.00.2	90° ELBOW CONNECTOR DIA.401,57" (opt.)	1	48	62.0020.01.2	PISTON SLEEVE POLY 2250	6
11	14.0030.32.2	PIPE MANIFOLD G 3/8"	2	48	62.0019.01.2	PISTON SLEEVE POLY 2260	6
12	80.3219.10.2	O-RING 3,0x30	1	49	81.8540.00.2	PISTON RING DIA.78	6
13	14.0029.32.2	PIPE MANIFOLD	8	50	62.0018.09.2	PISTON DIA.78	6
14	80.3309.00.2	O-RING 4,0 x 40	12	51	80.0021.00.2	RING DIA.15	12
14	80.3309.50.2	O-RING 4,0 x 40 (KIT VITON)	12	52	85.2006.70.2	PISTON PIN DIA.15	6
15	85.2576.00.2	CAP G.3/8	2	53	80.3209.00.2	O-RING 2,62x39,34	1
16	14.0031.32.2	PIPE MANIFOLD G1"1/2	1	54	80.1369.00.2	RING DIA.52	1
17	14.0001.09.2	CRANKCASE	1	55	85.1161.00.2	PIN D.4 X 45	24
18	80.2143.10.2	OIL SEAL DIA.35x52x7	2	56	41.0017.31.2	DIAPHRAGM OIL FILLER	1
19	81.2867.00.2	BEARING DIA.35x80x21	1	57	14.0116.32.2	SPACER	1
20	14.0016.01.2	SHAFT SPACER	2	58	14.9888.97.3	OIL FILLER KIT	1
21	14.0015.76.2	CONROD RING	2	68	14.0037.07.2	CAP	1
22	14.0027.11.2	CONROD	6	69	80.2191.10.2	OIL SEAL DIA.45x62x7	1
23	14.0002.26.2	CRANKSHAFT POLY 2250	1	70	81.2945.00.2	BEARING DIA.45X100X25	1
23	14.0009.26.2	CRANKSHAFT POLY 2260	1	71	14.0038.61.2	CIRCLIP DIA. 45	1
24	82.4079.00.2	GASKET DIA.13,2x17x1	1	72	14.0041.26.2	CRANKSHAFT "VC1"	1
25	86.3694.50.2	SCREW M12x20 UNI5931	6	72	14.0040.26.2	CRANKSHAFT "VM"	1
26	14.0018.61.2	MOUNTING RAIL	2	73	14.0111.07.2	HODRAULIC MOTOR FLANGE	1
27	81.4689.50.2	M12 UNI 5589 NUT	3	74	80.2178.10.2	OIL SEAL DIA.40x52x17	1
28	86.4139.00.2	SCREW M12x160	3	75	81.2900.00.2	BEARING DIA.40x80x18	1
29	81.2876.00.2	BEARING DIA.35x100x25	1	77	14.0110.61.2	SPACER	1
30	91.0110.72.2	COVER GASKET	1	78	14.0109.26.2	HOLLOW SHAFT "VC2"	1
31	14.0011.09.2	COVER	1	79	86.2683.00.2	SCREW M8x25 UNI 5931	4
32	86.2562.50.2	SCREW M8x20 UNI5931	6				