

Aurora & Calypso MK4-2 Turntable Manual

IMPORTANT NOTES

Never remove the silver strip on underside of platter.

Motor Pod blue light under platter must come on when platter is driven. If not reposition motor pod or raise deck till it does.

Never stretch the belt except to place it over the pulley. If you test stretch the belt you can damage it resulting in future breakage

It cannot be overstated that it is **VERY** important to read these instructions or the speed control may not function accurately.



Arm shown is not included

Introduction

Congratulations and thank you for choosing an Origin Live turntable. This should give many years of enjoyment, reliability and low maintenance.

It's critical that these instructions are read fully to achieve best performance. Underlined text is especially important.

The instructions are written for owners with no previous experience, however there are aspects of the deck that run contrary to expectations, so experts should not alter anything without absorbing these instructions first.

Diagrams cover 3 different turntables so are for guidance not exact representation.

Origin Live turntables are simple to set up. The instructions appear lengthy because they give proper explanation of factors that are different to conventional set ups. If you have a problem not covered in the instructions - you should speak to your dealer or refer to technical support on the Origin Live web site www.originlive.com - See top navigation bar "support".

There is a wealth of 3rd party information online. YouTube videos are particularly helpful on how to set up cartridges and tonearms should you need more help – Just Google what you need to know.

Keep the turntable packing box for secure future transport.

Safety Warnings

Voltages inside the Motor Pod are dangerous so it must not be opened.

Ensure Mains lead to the Motor Pod cannot be pierced by spikes or similar abuse. Also ensure the lead cannot cause anyone to trip.

Furthermore keep mains lead away from areas where liquids could spill on it.

Parts list

- ◆ Plinth & Sub-chassis - including 1 cable clip with nut & bolt.
- ◆ Bag of parts
 - Cork washer for arm
 - Oil bottle
 - 2.5mm allen key for arm clip
 - 3mm Allen key
 - 4mm Allen key
 - 8mm A/F spanner – (12 inch arms only)
- ◆ Platter
- ◆ Upgrade platter mat (if you have multi-layer platter this is attached to it)
- ◆ 1 Belt + Spindle for platter + Strobe card
- ◆ Motor pod
- ◆ Owner manual, assembly sheet, Packing instructions

Set up & operation

Sub-chassis for 12 inch tonearms need to be assembled to Plinth

Fit the 12 inch sub-chassis version to the deck as per instruction sheet at the beginning of this booklet.

Note the above diagram is for guidance only – it's not an exact representation.

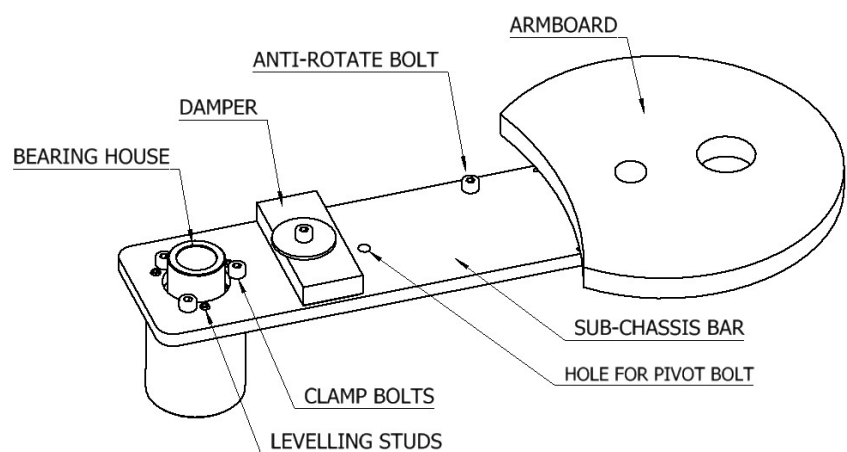

Fit the Spindle

Oil the bearing

Run approximately 17 drops of the oil supplied into the top of the bearing house. The spindle will appear a loose fit in the bearing house until the oil is added. Do not use anything other than Origin Live oil for performance reasons.

Insert the spindle

Inserting the spindle into the bearing house needs attention as careless handling can damage the bearing surfaces. Wipe the spindle surface first to ensure that it's absolutely clean and very gently insert it into the bearing house. If the oil does not overflow when the spindle touches the bottom then try 2 more drops repeatedly till you achieve overflow. Overflow can only be seen by looking at the top of the bearing house with the spindle inserted. You should notice an oil ridge around the spindle – see diagram below.

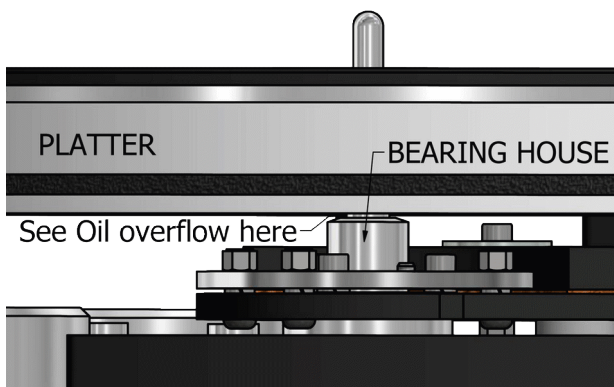

Wipe away excessive overflow at the top of the bearing house but be careful to leave oil clinging to the spindle as you need the top of the bearing to be lubricated by oil overflow and things like tissue paper can suck this area dry by capillary action. You should spin the spindle slowly after it has settled into the bearing to ensure even distribution of oil.

Note that when you oil the bearing, you can get a false impression of overflow if the spindle has oil on it - the oil simply scrapes off as the bearing slides in and ends up on the top of the bearing house. You can “feel” overflow when you insert the spindle and it meets resistance at the bottom. This is not a “thud” of the spindle hitting the bottom but rather a build up of pressure as the bearing lands on a bed of oil. By further pressing, you can then see the oil being squeezed out at the top.

Notes on the bearing:

The bearing has significant play “rock” which runs counter to expectations. However, this feature achieves very low friction levels. The spindle effectively rotates on a thick film of oil without contacting the bearing sides.

This means there is almost imperceptible platter

movement in rotation. Small low frequency deviations of this nature are insignificant to performance and far outweighed by the advantages of low friction and reduced vibration.

All platters are rigorously checked for level spinning up to 45rpm - if you notice significant platter flutter once the belt is fitted, then remove the platter and clean taper surfaces. Refit it till it sits true.

Do not spin the platter faster than 45rpm as the bearing relies on a high precision oil film designed for optimal sound quality within a specific speed range. At higher than normal running speeds there will be slight platter flutter.

Fit the Platter

Fit the platter gently over to the spindle but ensure the tapered mating surfaces are absolutely clean before assembly by wiping with tissue paper.

Once the platter is located on the spindle press it down firmly at the centre using your fingers to provide equal force on either side of the spindle. This ensures accurate seating of the platter on the tapered spindle.

Finally add the platter mat ensuring the printed logo is uppermost for sound quality reasons. **Note** – the mat is already fitted if you have a Multi-Layer platter (see below).

For Multi-Layer platter if included

Holding the Multi-layer platter

The top thin layers of the multi-layer platter are fragile so do not hold the weight of the platter using the top layers – also avoid placing the platter upside down on surfaces as this can damage the top surface.

Concentricity of upper Layers

The upper layers of the platter work best as a loose fit. This means that there can be very slight movement of the layers when pushed.

This is not a design flaw but you may notice that the layers are not always perfectly concentric with the platter. Performance is not affected however as the centre spindle is absolutely concentric with the platter which means your record will be held concentric (unless it's hole is off centre).

Set the Height of the Plinth

To set the plinth height correctly, place the motor pod just beside the platter as shown below.

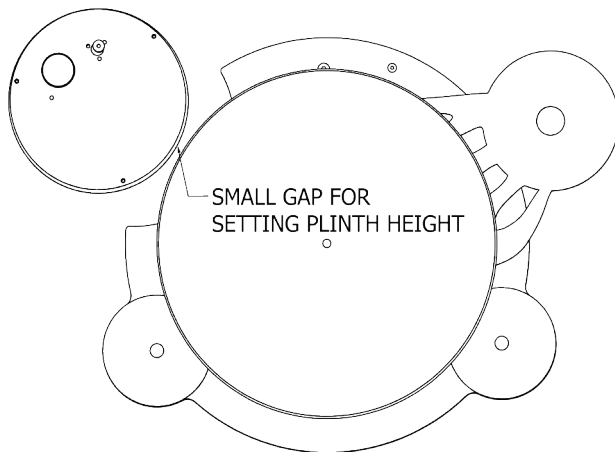

Set plinth height using the adjustable feet, to give the platter 4 to 7mm clearance between the top of the motor pod screws and the underside of the platter as shown below.

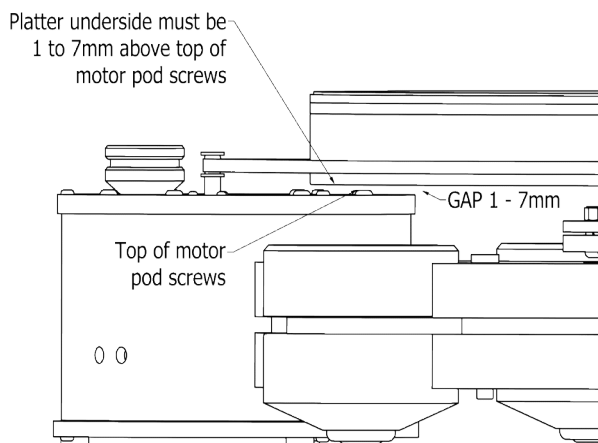

Adjust deck feet

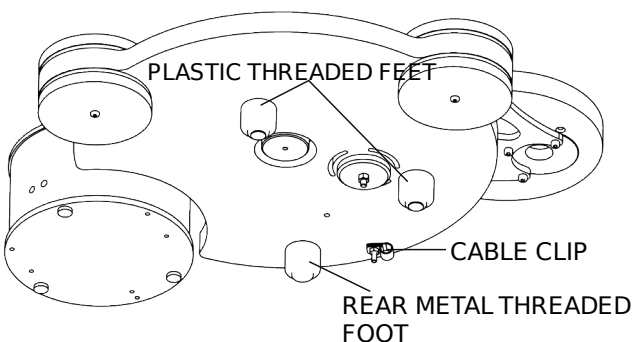

Set the plinth height by rotating the 3 adjustable feet. It helps to lift the deck slightly for access to each foot in turn.

The top of each foot should not touch the underside of the plinth as performance is best when the foot contacts the thread alone.

Level the deck using platter as reference

For accurate levelling place a bubble gauge on the platter. Now adjust the feet till the armboard is level.

Position motor pod & fit belt

Power up

Plug the Motor Pod directly into a mains plug. We suggest omitting mains conditioners, filters or anything with surge protection as these can be highly detrimental for performance. The aforementioned items inflict no damage so you can experiment with their inclusion if you wish.

Ensure items such as power amps or power supplies with strong electromagnetic fields are kept away from the motor pod (i.e not directly underneath or alongside).

Motor Pod position

Move the pod into position as shown below. The pod and pod cable should not touch the plinth so rotate the pod if necessary. Check the pulley to platter distance is initially 217mm or slightly more.

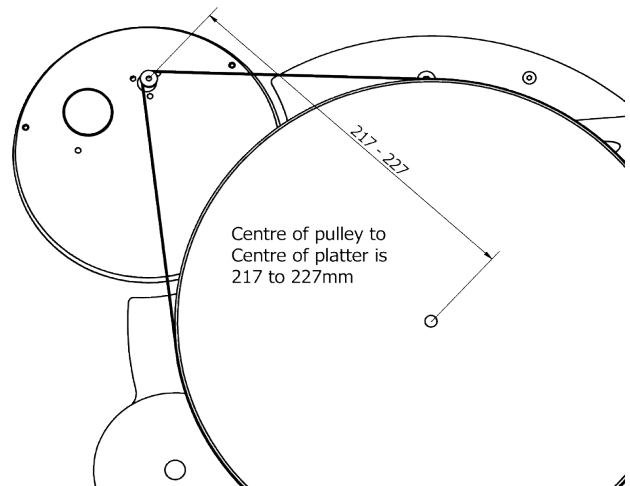

Fit the belt over the platter first and then pull it over the motor pulley taking care not to twist it.

To set belt tension, simply move the pod.

As a rough guide, centre of platter spindle to centre of motor pulley should be between 217 - 227mm. Note - Low belt tension can result in slight platter flutter but for a new belt start at 217mm.

The belt initially stretches slightly during the first hours of use so leave final tension adjustment till 48 hours have passed.

***The only time you should ever stretch the belt is to place it over the pulley. If you test stretch the belt you can damage it resulting in future breakage. Never pull the belt on either side of the glued joint to see how strong it is.

Final positioning of motor pod

To set correct belt tension finally, lift the belt off the pulley and let it lose its tension almost completely whilst still holding it gently - With no tension

whatsoever in the belt it should be approx 7mm off the nearside of the motor pulley (flange edge) as per diagram below. Move the pod till the pulley is this distance from the belt, then stretch the belt to fit over the pulley.

BELT UNSTRETCHED SHOULD BE 6 to 9mm from Pulley flange

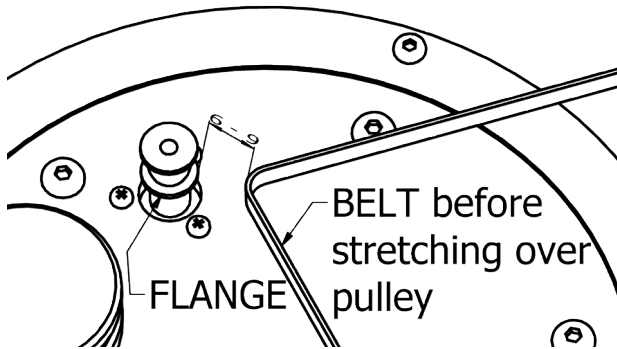

Check belt rides correctly

Rotate the platter by hand for a couple of turns and check that the belt still sits between the 2 flanges of the pulley. If this is not the case and it has ridden up onto a flange push the belt back onto the crown (Curved portion between the flanges) and turn the platter. Check the belt remains on the crown.

BELT RUNNING POSITION

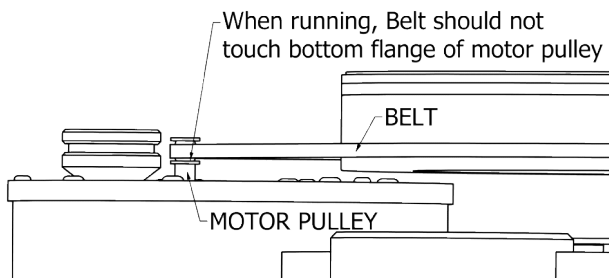

People sometimes comment that the plastic pulley looks cheap - However it's made from a special plastic which sounds better than metal and is significantly more expensive to machine.

Note that belt grip varies according to the way it's fitted. This means the deck will sound slightly different if you refit the belt inside out or upside down from previously. Therefore when removing and refitting the belt take care to replace it with the same side in contact with the running surfaces.

Position the Motor Pod correctly

The speed is controlled very accurately by a light sensor



reading the speed of the platter. You will notice 3 closely spaced holes near the edge of the motor pod. These holes house the light emitters and sensors that read platter speed and must be positioned under the rim of the platter as shown in photo below.

The sensor reads the silver strip on the underside of the platter (see below). This strip must never be removed or the speed will not be correct.

There are 2 blue LEDs which can light up (the other 2 never do as they are sensors). The blue LED nearest the switch knob remains lit permanently when the power is connected. The second blue light directly below the platter, only comes on when the platter is rotating and shows that the speed is correct. We call this the "speed sensor light"

When the platter is rotating you should always see the blue speed sensor LED below the platter, light up (shown in the rectangle outline shown in preceding illustration.)

Never disturb, poke or press any LEDs as it will wreck speed reading.



Note that only the LED next to the knob lights up at this stage and will remain on to show item is connected to the mains.

Set up for Light speed control

Check that there is at least 4mm of clearance between the top of the pod and the platter or the light sensor may not work.

Switch on the speed to 33 rpm by turning the motor pod knob clockwise one click. The deck should start and the blue sensor light appear shining through the platter.

If the sensor light does not appear then switch off and raise the deck by 1mm using the adjustable feet. This increases the gap between the top of the Motor Pod and the Platter. Switch on again and the blue light should appear. If not, repeat the aforementioned process. The blue sensor light should only shine when the platter is rotating correctly. It turns off when the switch is turned off or the pod is not positioned correctly.

Once the Blue light is functioning correctly, it's important to raise the plinth at least another 0.5mm to ensure that the blue light is not in a "borderline" condition leading to inaccurate control or turn off at a later date.

The other factor that may prevent the blue sensor light from lighting up is if the pod is positioned with the 3 LED holes not underneath the rim of the platter. Ensure this is not the case.

Initially motors may be a little noisy but soon settle down within a couple of days continuous running. The sound quality also improves substantially after 40 hours of running in.

Fine Tuning Motor screws

It should not be necessary but you can fine tune the motor mount to give minimum noise by adjusting the tightness of the 3 screws next to the motor pulley for minimal tension - "just nipped" on the small rubber O ring. Always check that the motor pulley is approximately vertical and that the belt runs clear above the bottom flange as per earlier diagram.

Control knob operation

The motor is "off" when the speed control knob on the pod is turned fully anti-clockwise and the indent on the knob aligns to the reference point.

Turn the knob one click clockwise to turn the motor on at 33.3 rpm - The second click clockwise is 45rpm.

Operating the strobe

You can check the speed of your deck by placing the strobe disc on the record to be played. The strobe rings are labelled on the centre of the disc for speed and mains frequency.

Use correct lighting

The strobe effect shows best in fluorescent light, although an ordinary bulb held about 2 feet from the strobe disc will also work fine. The bulb flickers at 50 Hz in the EEC and 60 Hz in the USA.

You can purchase bayonet fitting fluorescent or halogen bulbs to fit normal lamps. Try to shut out daylight when carrying out speed reading. Also be aware that energy saving lighting with switch mode high frequency power supplies or certain energy saving bulbs will not work with the strobe disc.

Reading the strobe

As you play the record, watch the relevant ring on the strobe disc. Read the speed as described in next sub-heading until marks on the ring concerned appear stationary. It sometimes helps to stare the strobe but focus your eyes on infinity.

Alternative methods

There are other strobes which are easier to read such as the KAB strobe which can be found on our web site under vinyl measurement accessories.

There is also a phone app that you can download for Android or IOS. You simply then place the phone on the platter and it reads the speed (but not very reliably). Best results are achieved with the phone close to the centre of the platter and ideally it should be supported over the centre spindle of the platter.

Notes on Belt & Motor running

Motor Tilt

Check that the belt rides clear of the flanges – nearly touching is OK but if the belt sinks down to touch the flange you need to either increase belt tension slightly or adjust the tilt of the motor by turning the small cross-head motor mounting screw positioned nearest the platter.

Motor Noise

DC motors are often slightly noisy initially and never completely silent in comparison to a/c motors. This may be due in part to the high conductivity precious metal brushes. These produce much lower levels of vibration and hence better performance.

Like most turntable manufacturers we recommend you leave the turntable running between changing records as this reduces belt wear due to constant stopping and starting.

Why measurements can be misleading

The figures on speed accuracy of the deck are well ahead of industry standards however it's worth mentioning that

the Fleikhart measurement system is now well reported on the web to be inaccurate due to off-centre discs and poorly recorded tone. It has currently been withdrawn from production.

Similarly Mobile phone apps are only a rough guide.

Fit the tonearm

Mounting Origin Live arms

All newer Origin Live arms have built in VTA adjustment and can be fitted directly to the arm board as illustrated below.

If you have an older Origin Live or Rega tone-arm which has a threaded base but no vta adjustment, you can fit a threaded VTA adjuster. The adjuster must be threaded onto the base of the arm first and oriented such that the flange is uppermost.

Insert your arm through the hole in the arm board.

Next fit the cork washer followed by the large clamping nut as shown in the diagram on this page.

Lastly fit the tone-arm cables through the cable clip on the underside of the deck. This improves performance slightly and safeguards the cables from stressing their joint at the arm base in the event of being "tugged". The cables should not be tight but form a gentle loop.

If clamping the cable is undesirable you can omit this step. We will cover setting the arm to exactly the correct height later as you need to do a number of other things first.

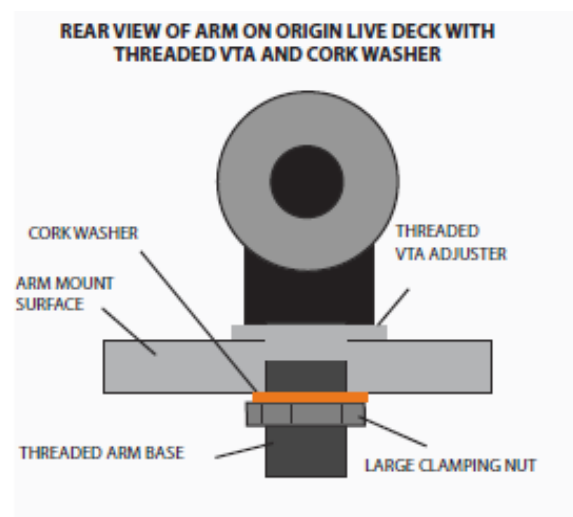

Final setup of tonearm

You should refer to your tone-arm instructions for detailed set up of the arm and cartridge alignment.

Fit the arm cable clip

Pass the arm cable through the cable clip supplied and fasten in position with the M5 bolt located in the threaded hole near the rear foot. Leave a slight droop on the cable so that it isn't "tight". The bolt is helpful to

minimize cable vibration.

Note – Silver Hybrid cable is relatively thick but both left and right channels will fit through one of the cable clips supplied.

Maintaining your deck

Cleaning

To avoid belt vibration or wow & Flutter, it aids performance to clean all running surfaces every 3 months with mentholated or surgical spirit. Wiping (not dipping) with Acetone (Nail Varnish remover) is an alternative, as is iso-propanol.

Belts can also be cleaned with soap & water then rinsed thoroughly. Rubber care products can leave behind a slippery residue.

To clean the deck, use a damp soft lint free cloth and wipe gently – if you have grease marks etc then you can use a general-purpose anti-smear, car window cleaner such as Auto-glym “Fast glass”, but only if necessary. Wax furniture polish is to be avoided. Do not spray directly on the turntable as it may clog up the cartridge internals etc but rather spray onto a soft polishing cloth and then use it on the turntable. Do not use tissue paper or kitchen cleaning paper towels as paper is abrasive and can put faint scratches in the polished surface.

Scratch removal

If minor abrasions occur on the surface, you can remove them using a proper plastic scratch remover polish such as “Xerapol” by E.V.I of Germany or “Plastic Clean & Shine by Novus inc of USA. Avoid Car and other polishes as they leave light scratching or bloom.

Every 2 Years or so

The deck is not prone to going out of tune:

Check that the sub-chassis curved damper is tensioned lightly onto the plate every 2 years or so as the damper can compress a little over time.

Check belt tension is correct using the method described for final pod positioning. All belts stretch over the years so the motor pod may need to be moved out further than the initially specified 227mm maximum.

Depending on your use of the deck, the belt should ideally be replaced every 2 to 4 years.

Every 3 years

Only use Origin Live oil. Oil should be replaced every 3 to 4 years so you will need to clean out the old oil with a lint free paper towel or similar wrapped around a thin rod. When you do this, be sure to also wipe oil off the spindle as this may contain microscopic contamination that's not visible.

If you ever withdraw the main spindle you should put a few drops of oil into the bearing house to compensate for any possible loss occurring in the withdrawal.

Never tamper with the bolt in the bottom of the bearing

or oil leaks will occur and you will probably not succeed in re-tightening it.

Alternative Mats?

Many of the mats on the market have been tried on our platters and do not work better than our own award winning mat (included with this turntable) so we recommend saving yourself the expense of trying them.

Troubleshooting

Refer to the Origin Live website > Support > Technical Support > Turntables > Troubleshooting if you have any problems.

If for any reason the strip of silver foil under the platter is damaged it can be replaced by cutting a strip of aluminium kitchen foil to approx 4mm wide and gluing it to the underside of the platter as shown below. Note the most reflective surface of the foil must face the top of the motor pod.

REPACKING METHOD - Please read carefully and pack exactly as instructions show.



BOTTOM LAYER OF PROFILED CARDBOARD

Wrap plinth in polythene bag before lowering into box

Place foam insert into cut out here and align foam cut outs with the cut outs in the card underneath.



Place motor Pod on foam in the orientation shown.

Note Motor pod feet must fit into foam cut outs underneath and the silver switch on top must be exactly where shown to avoid fouling the top layer of profiled cardboard yet to be added.

Insert Motor lead into side pocket as shown



INSERT TOP LAYER OF PROFILED CARDBOARD

Ensure this layer fits below the top flaps of the box. Also ensure that fit is snug on top of motor pod and that the motor pod switch has clear space over it.

Wrap platter and platter mat in polythene bag before placing it **upside down** in foam cut out



Place bag in side pocket

- Bag Contains: Strobe card
- Belt (Rolled up into a spiral to avoid deformation),
- Cork washer for arm,
- Oil bottle (in polythene bag)
- Allen keys 4mm, 3mm & 2.5mm



Place card rectangle over platter to protect it from knife cut when box is sliced open.

Instruction manual

