

GFP-915

Wide Bandwidth Stereo Preamp



ADCOM

ABOUT ADCOM

PERFORMANCE AND VALUE

In the world of high performance electronics, Adcom has done the impossible: make state of the art components that are easy to use at an affordable price. In doing this, Adcom has created a revolution in the world of consumer electronics. By creating some of the most renowned components and offering them at affordable prices, Adcom has enabled more people to enjoy their favorite music and movies at top performance levels. Perhaps Audio Magazine said it best: “No competing company I know can provide a similar balance of sound quality, power and affordability.”

AWARD WINNING

Innovation is our stronghold, and our numerous awards year after year prove that we're never satisfied to rest on our reputation. From our legendary high current amplifiers to our state-of-the art digital processors, Adcom components consistently impress even the most demanding audiences. Adcom components have won over 25 Product of the Year and Special Recognition citations from Audio Video International, 3 Diapason D'Or Awards, 7 Consumer Electronics Show Design and Engineering Awards, and have appeared on Stereophile's "Recommended Components" lists over 70 times since 1988. A reputation worth its weight in gold.

ENGINEERING PASSION

Every Adcom component is not only designed to reproduce the highest quality sound and picture, but to also deliver the greatest possible value. It is our engineers' passion for perfection that has enabled our components to be judged the equivalent of others costing two, three, or even five times as much. Our engineering team consistently strives to develop and design products that will exceed your expectations. Our goal at Adcom is to let more consumers hear high-end quality sound and see high-end video without paying high-end prices.

All Adcom components are the result of a long-standing dedication to innovation, quality, simplicity and value. Adcom, we have the power, and now so do you.

This document is subject to change. Please check our website for the most up-to-date version.

ADCOM is a registered trademark of ADCOM LLC

Copyright © 2010 ADCOM LLC. All rights reserved. No part of this manual may be reproduced or electronically transmitted without the express written consent of ADCOM LLC.

THE FOLLOWING PRECAUTIONS AND SAFETY INSTRUCTIONS ARE REQUIREMENTS OF UL AND CSA SAFETY REGULATIONS

Warning: To reduce the risk of fire or electric shock, do not expose this unit to rain or moisture.



The graphic symbol of a lightning flash with an arrow point within a triangle signifies that there is dangerous voltage within the unit and it poses a hazard to anyone removing the cover to gain access to the interior of the unit. Only qualified service personnel should make any such attempt.



The graphic symbol of an exclamation point within an equilateral triangle warns a user of the device that it is necessary to refer to the instruction manual and its warnings for proper operation of the unit.

Do not place this unit on an unstable cart, stand, tripod, bracket, or table. The unit may fall, causing serious

injury to a child or adult, and serious damage to the unit. Use only with a cart, stand, tripod, bracket, or table recommended by the manufacturer or sold with the unit. Any mounting of the device should follow the manufacturer's instructions, and should use a mounting accessory recommended by the manufacturer.

Read all the safety and operating instructions before connecting or using this unit.

Retain this notice and the owner's manual for future reference.

All warnings on the unit and in its operating instructions should be adhered to.

All operating and use instructions should be followed.

Do not use this unit near water. For example, near a bathtub, washbowl, kitchen sink, laundry tub, in a wet basement, or near a swimming pool.

The unit should be installed so that its location or position does not interfere with its proper ventilation. For example, it should not be situated on a bed, sofa, rug, or similar surface that may block the ventilation openings; or placed in a built-in installation, such as bookcase or cabinet, that may impede the flow of air through its ventilation openings.

The unit should be situated away from heat sources such as radiators, heat registers, stoves, or other devices (including amplifiers) that produce heat.

The unit should be connected to a power supply outlet only of the voltage and frequency marked on its rear panel.

The power supply cord should be routed so that it is not likely to be walked on or pinched, especially near the plug, convenience receptacles, or where the cord exits from the unit.

Clean unit only as recommended in its instruction manual.

The power supply cord of the unit should be unplugged from the wall outlet when it is to be unused for a long period of time.

Care should be taken so that objects do not fall, and liquids are not spilled, into the enclosure through any openings.

This unit should be serviced by qualified service personnel when:

- The power cord or the plug has been damaged; or
- Objects have fallen, or liquid has been spilled, into the unit; or
- The unit has been exposed to rain, or liquids of any kind; or
- The unit does not appear to operate normally, or exhibits a marked change in performance; or
- The device has been dropped, or the enclosure damaged.

DO NOT ATTEMPT SERVICING OF THIS UNIT YOURSELF.
REFER SERVICING TO QUALIFIED SERVICE PERSONNEL.

ATTENTION

POUR PREVENIR LES CHOCS ELECTRIQUES NE PAS UTILISER CETTE FICHE POLARISEE AVEC UN PROLONGATEUR, UNE PRISE CE COURANT OU UNE AUTRE SORTIE CE COURANT, SAUF SI LES LAMES PEUVENT ETRE INSEREES A FOND SANS EN LAISSER AUCUNE PARTIE A DECOUVERT.

CAUTION TO PREVENT ELECTRIC SHOCK DO NOT USE THIS POLARIZED PLUG WITH AN EXTENSION CORD, RECEPTACLE OR OTHER OUTLET UNLESS THE BLADES CAN BE FULLY INSERTED TO PREVENT BLADE EXPOSURE.

CAUTION POWER LINES

Any outdoor antenna must be located away from all power lines.

OUTDOOR ANTENNA GROUNDING If an outside antenna is connected to your tuner or tuner / preamplifier, be sure the antenna system is grounded so as to provide some protection against voltage surges and built-up static charges. Section 810 of the National Electrical Code, ANSI/NFPA No. 701984, provides information with respect to proper grounding of the mast and supporting structure, grounding of the lead-in wire to an antenna discharge unit, size of grounding conductors, location of antenna discharge unit, connection to grounding electrodes, and requirements for the grounding electrode.

Use No.10 AWG (5.3 mm²) copper, No.8 AWG (8.4 mm²) aluminum, No.17 AWG (1.0 mm²) copper clad steel or bronze wire, or larger, as a ground wire.

Secure antenna lead-in and ground wires to house with stand-off insulators spaced from 46 feet (1.221.83 m) apart. Mount antenna discharge unit as close as possible to where lead-in enters house.

Use jumper wire not smaller than No.6 AWG (13.3 mm²) copper, or the equivalent, when a separate antenna grounding electrode is used. See NEC Section 810-21 (j).

EXAMPLE OF ANTENNA GROUNDING AS PER NATIONAL ELECTRICAL CODE INSTRUCTIONS CONTAINED IN ARTICLE 810. RADIO AND TELEVISION EQUIPMENT.

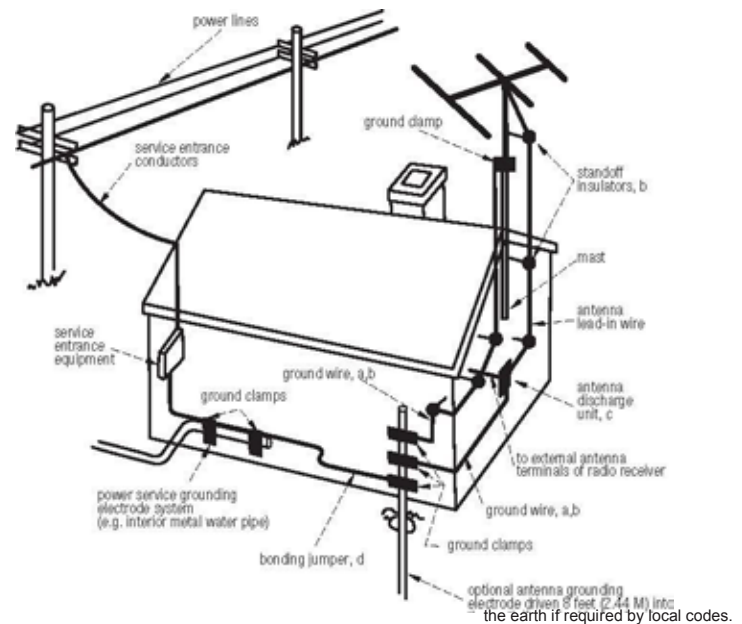

NOTE TO CATV SYSTEM INSTALLER This reminder is provided to call the CATV system installer's attention to Article 82022 of the National Electrical Code that provides guidelines for proper grounding and, in particular, specifies that the cable ground shall be connected to the grounding system of the building, as close to the point of cable entry as practical.

Introduction

Congratulations on your decision to purchase the GFP-915 stereo preamplifier. Two channel audio is better than ever! The new DVD Audio and SACD formats can support a wider frequency spectrum (100kHz) and greater dynamic range (144dB) than conventional CD. The GFP-915 is designed to capture all the fidelity that high resolution audio has to offer, with precision broadband components and an ultra low noise floor. Equipped with a processor loop, a tape loop and a phono stage, this new ADCOM preamp hasn't forgotten about your legacy components. Audition the GFP-915 paired with an ADCOM power amp and CD / DVD player and rediscover the magic of two channel. To realize the full potential of your new stereo preamplifier, and before making any connections to it, please read these operating and installation instructions thoroughly.

Key Features

- Class A line level preamp
- High resolution audio bandwidth
- 7 source audio inputs
- Bluetooth/Optical /USB audio inputs
- Phono input stage
- Main & Record outputs
- External remote in and loop
- Bass, treble, and balance adjust
- Front panel headphone input
- Remote control and rs-232 control

Unpacking the GFP-915

Before your new ADCOM preamplifier left our factory, it was carefully inspected for physical imperfections and tested for all electrical parameters as a routine part of ADCOM's systematic quality control. This, along with full operational and mechanical testing, should ensure a product flawless in both appearance and performance. After you have unpacked the GFP-915, inspect it for physical damage. Save the shipping carton and all packing material as they are intended to reduce the possibility of transportation damage should the preamplifier ever need to be shipped again.

In the unlikely event damage has occurred, notify your dealer immediately and request the name of the carrier so a written claim to cover shipping damages can be initiated. The right to a claim against a public carrier can be forfeited if the carrier is not notified promptly in writing and if the shipping carton and packing materials are not available for inspection by the carrier. Save all packing materials until the claim has been settled.

Placing the GFP-915

Although the GFP-915 does not generate much heat, it is good practice to ensure the amplifier's long-term, trouble-free operation to provide adequate ventilation for the unit. Therefore, the GFP-915 should be kept away from external sources of heat such as radiators and hot-air ducts. We recommend that you exercise care when placing components on top of the GFP-915. If you are placing a heat producing component (such as an amplifier) on top of or below the GFP-915, it is recommended that you allow at least 3 inches vertical spacing for proper airflow.

If your system includes the use of the phono input, you may find that placing components above or under the GFP-915 may induce hum, caused by the proximity of their power transformer to the phono cables or input jacks. If this should occur, moving the components will usually help reduce the hum.

If you observe these recommendations the GFP-915 will perform reliably in any reasonable environment.

You should also pay attention to such normal considerations as protection from excessive dust and moisture. Dust on the surface of the cabinet can be easily and safely removed with a duster such as made by Swiffer™. Finger prints can be removed with a soft cloth dampened with a mild non-ammonia cleaner.

The optimal performance of your new GFP-915 will ultimately depend on the care with which you make the connections between the amplifier, preamplifier and loudspeakers. All input and output signal connections should be made only with high quality, low-loss, low capacitance cables. For recommendations of the type and quality of interconnections that are best for your applications, consult with your ADCOM retailer.

Safety Information

There are no user serviceable parts inside. Refer all servicing to qualified service personnel.

The unit must be connected to a power supply only of the type and voltage specified on the rear panel. Connect the component to the power outlet only with the supplied power supply cable or an exact equivalent. Do not modify the supplied cable. Do not defeat grounding and/or polarization provisions. The cable should be connected to a 3-pin polarized wall outlet, matching the wide blade of the plug to the wide slot of the receptacle. Do not use extension cords. Do not route the power cord where it will be crushed, pinched, bent, exposed to heat, or damaged in any way. Pay particular attention to the power cord at the plug and where it exits the back of the unit. The power cord should be unplugged from the wall outlet if the unit is to be left unused for a long period of time. Immediately stop using the component and have it inspected and/or serviced by a qualified service agency if:

- . The power supply cord or plug has been damaged;
- . Objects have fallen on or liquid has been spilled into the unit;
- . The unit has been exposed to rain;
- . The unit shows signs of improper operation; or
- . The unit has been dropped or damaged

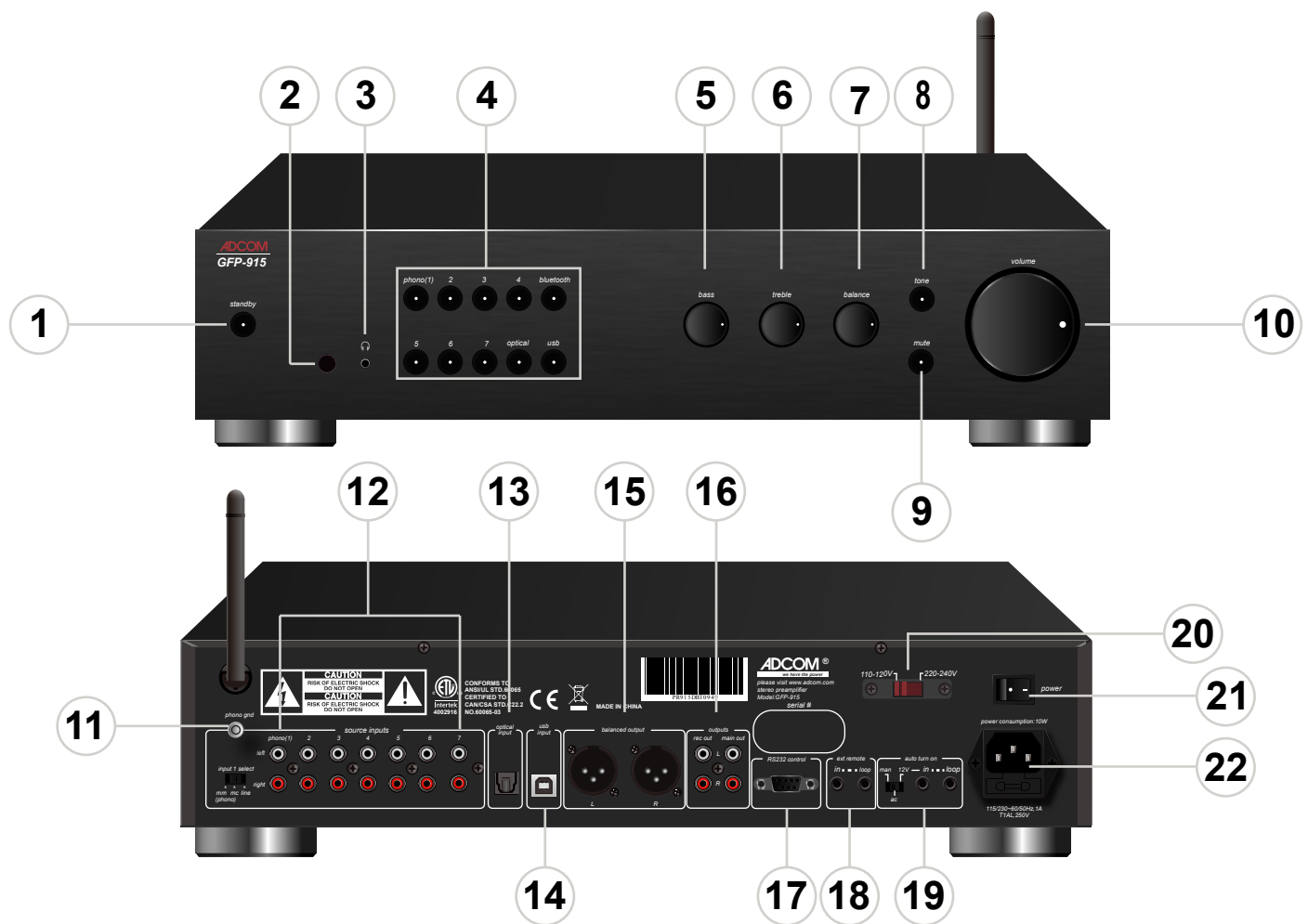

Description of Unit: Front Panel

[1] Standby button

Toggles the GFP-915 in and out of Standby mode. When in standby mode, the GFP-915 is activated by pressing either the remote control power button or toggling the front panel power switch. When the GFP-915 is active, the LED indicator in the Standby button will illuminate.

[2] IR Sensor

This lens protects the infrared receiver which receives commands from the remote control. Note: the pathway between the lens and remote control must be free of obstruction for the remote control to operate the GFP-915.

[3] Headphones Jack

Headphones may be used through the use of the phones output jack on the front panel. This jack will accept a standard 3.5mm stereo headphone plug.

[4] Source Selections

These seven buttons select the source you desire for listening. When you select phono(1), 2, 3, 4, 5, 6 or Optical, USB, Bluetooth, the selected source is the record outputs. The ten source select buttons are also available on the remote control.

[5-6] Bass & Treble Knobs

The bass and treble knobs control the bass and treble frequencies by increasing or decreasing levels.

[7] Balance Knob

Balance control provides adjustment for greater accuracy of stereo imaging.

[8] Tone Button

This button is used to engage the bass and treble controls. In the out position, the tone controls will have no effect.

[9] Mute Button

Pressing this button mutes the main outputs. To turn the mute feature off, press the mute button again. Note: turning the volume knob on the front panel will not deactivate the mute feature.

[10] Volume Knob

The front panel volume control knob is motorized. It may be adjusted either by hand or with the volume buttons on the remote control. The point dot on the volume knob indicates the volume level.

Description of Unit: Rear Panel

[11] GND Ground Post

To reduce the chance for hum connect the turntable ground lead to this attachment point.

[12] Source Inputs

Source 1-7 inputs (R/L) Connects to the line outputs of a CD player or other analog audio source component. Up to seven analog audio source devices can be connected.

[13] Optical Inputs

Connect device such as DVD with optical cable to the Preamp

[14] USB Inputs

USB B-port for connection to a computer. Data up to 192 kHz/24 bit

[15] Balanced output:

For sending balanced signals to another amplifier.

[16] Stereo Outputs

Rec Output: Connect rec output to the Record or Input jacks of a recording device.

Main Output: A line level stereo output that connects to your amplifier's inputs.

[17] RS232 Control

The Adcom GFP-915 can be controlled via the serial RS-232 port. The serial port can be connected to a system controller, PC or 'dumb terminal' via a straight through standard 9-pin (DB9) serial port cable (MALE on one end and FEMALE on the other end).

[18] Ext Remote

A remote infrared sensor can be connected here.

[19] Auto turn on

A trigger, if properly hooked-up, can prove to be very convenient.

-in input jack use the 12V DC or AC trigger in conjunction with another device to turn the GFP-915 on and off. The trigger output from the other device should go to the trigger input on the rear panel of the GFP-915.

-loop output jack is provided to allow trigger control of additional components in your system.

[20] Voltage switch

Sets the GFP-915 voltage to 120V (U.S. standard) or 230V (international standard).

[21] Main power switch

Switches the GFP-915's main power on and off.

[22] AC Input

Connects the GFP-915 to a standard electrical outlet using the supplied power cord. Use the provided standard IEC AC cord to provide power to the unit. The plug is a polarized type. for electrical safety, observe proper polarization at main outlet and do not modify plug in any way. If it is ever necessary, replace the fuse with a fuse of identical type and rating for continued protection. See "Troubleshooting" for more information.

Input 1 select

Sets the input level for input source 1 to mm or mc for phono cartridge input or line for other analog devices.

Bluetooth Pairing:

1. Activate Bluetooth on your phone/tablet and start searching for new Bluetooth devices.
2. Select the Bluetooth mode of the amplifier.
3. The LED light of the amplifier will start flashing, the unit enter into Bluetooth pairing mode, you will see "GFP-915" in your audio device, then connect and pair it, no need password.

4. It will connect with the previous device automatically next time.
5. The distance from this unit and your device could be up to 10 meters, but please notice that it may vary much based on the environment.

Remote Control

The supplied remote control, pictured here, duplicates the frequently used front panel controls. Two AAA batteries are included. The model number of the remote control is RC915.



SYMPTOM	POSSIBLE REASON	POSSIBLE SOLUTION
Power LED does not glow. No sound	AC Power Cord(s) not plugged in. AC Fuse(s) failed. Transformer thermal protection engaged. 12V DC triggering malfunctioning.	Plug in AC Power Cord(s). Replace AC Fuse(s). Wait until unit cools down. It will reset. Reset power switch manually. Check connection of 12V DC trigger at source.
Power LED glows, but no sound	Preamp or source unit is not on. Connections in rear of amp are loose.	Make sure whole system is on. Verify all connections on rear of amp.
One channel not producing sound	INPUT(s) or OUTPUT(s) connector disconnected or loose. Speaker disconnected. Internal protection engaged.	Verify both connections on that channel. Verify connection at speaker. Bring to Dealer or Service Center.
Hum from all speakers at any volume	Ground loop (difference in ground voltages between components).	If Cable TV is present (see Note 1). If Cable TV is not present (see Note 2).
Hum from all speakers (hum goes up or down with volume)	Problem with source unit (CD, tape, etc.), or RCA cable connecting that source unit to the preamp.	Try different source (tuner, tape, etc.) and/or different RCA cable.
Hum from the amplifier itself	Some major appliance, dimmer, halogen or fluorescent light is creating interference.	Make sure all appliances, dimmers and suspect lights are off.

Troubleshooting

Use the troubleshooting notes above to solve common situations that don't require professional attention. If the steps stated in possible solution do not resolve your problem, then please contact your ADCOM dealer or call the ADCOM customer service department. Any problems not covered here should be brought to the attention of your ADCOM dealer or ADCOM customer service department.

A special note on "hum:" When there is a low-volume "hum" audible throughout your speakers, even with the main volume turned all the way down, you have a common phenomenon known as a "ground loop." A ground loop is basically a difference in ground voltages between two or more components which are connected electrically and which creates multiple current paths where there must only be one. This difference in potentials creates a 60Hz low-level sound (approximately a low A), that seems to be a "hum."

Hum can be caused by adding new components to your system, but that does not imply there is anything electrically wrong with any new component. With the advent of audio/video and home theater systems, the problem has become commonplace. Generally, the cause is the Cable-TV incoming signal line. This new incoming line may add an additional ground at a different potential to the AC line ground of your other equipment (refer to note 1 and 2, to troubleshoot a hum problem).

Note 1: Cable TV systems can sometimes contribute to ground loop problems which cause "hum." To determine if your cable system is the contributing factor, disconnect the

Cable-TV incoming signal line (round, 75Ω) at the wall, or the first component the cable is connected to (i.e. the cable box, or VCR). If the hum is no longer present, you must insert a "75Ω ground loop isolator" before reconnecting the line. You should check with your ADCOM dealer to obtain one. If the "75Ω ground loop isolator" works only partially or not at all, then please read note 2 to complete the troubleshooting procedure.

Note 2: Make sure that the power amplifier is at least 6" from processor or other equipment using microprocessors. Usually putting another component between them is sufficient to minimize the hum. If this does not reduce the hum, turn the system off and disconnect all Inputs from the amplifier. If the hum still persists, then your dealer or service center must examine the unit/system. If the hum disappears, try another set of RCA cables. Connect one RCA cable at a time to see if one specific cable is responsible. If any or all cables cause the hum to appear, then the unit should be evaluated for proper operation by your dealer or authorized service center. Please see our website for a list of authorized service centers in your area.

Servicing

ADCOM has a technical service department to answer questions pertinent to the installation and operation of your unit. In the event of difficulty, please contact us for advice. If your problem cannot be resolved through our combined efforts, we may refer you to an authorized repair agency, or authorize return of the unit to our factory.

ADCOM LLC

PO Box 54087

Phoenix, AZ 85032

Phone, Fax or Email inquiries to:

Voice: (480) 607-2277

Fax: (623) 505-9523

Monday through Friday, 9:00 AM to 5:00 PM MST

Email: service@adcom-usa.com

For fax inquiries, please include a return fax number for the reply. When calling or writing about your ADCOM product, be sure to note and refer to its serial number as well as the date of purchase and the dealer from whom it was purchased. In any communications to us, please include a daytime phone number where we may reach you. In the event the unit needs to be sent to a service center, you will be instructed on the proper procedure when you call or write for a return authorization. Under no circumstances should your unit be shipped to our factory without prior authorization, or packed in other than its original carton and fillers.

Always ship prepaid via FEDEX or UPS. Do not ship via Parcel Post, since the packing was not designed to withstand rough Parcel Post handling. Improper packaging and shipment of the product will void your warranty coverage.

Warranty – USA & Canada

This warranty is only valid if this product was purchased and used in the United States or Canada. Warranty coverage for products purchased and/or used outside of the United States and/or Canada is provided by local ADCOM authorized dealers and distributors in the country where the product was sold. Consult your local dealer or distributor about the terms of your warranty.

ADCOM LLC, makes the following limited warranties. These limited warranties extend to the original purchaser or any person receiving this product as a gift from the original purchaser and to no other purchaser or transferee. There is no warranty provided by ADCOM for products purchased from unauthorized sellers, dealers or from previous owners.

Limited Two Year Warranty (Home, Non -Commercial Use Only)

Briefly, ADCOM warrants this product against defects in materials or workmanship for a period of two (2) years after the date of original retail purchase from an ADCOM authorized dealer. During this period, ADCOM will repair or replace a defective product or part, at our option, with a new or refurbished product or part without charge to you. Consult the warranty document enclosed with the product or our website for the complete terms and conditions of the warranty.

Limited Ninety (90) Day Warranty (Commercial Use Only)

Briefly, ADCOM warrants this product against defects in materials or workmanship for a period of ninety (90) days after the date of original retail purchase from an ADCOM authorized dealer. Consult the warranty document enclosed with the product or our website for the complete terms and conditions of the warranty.

No person, agent, distributor, dealer, or company is authorized to change, modify or extend the terms of ADCOM warranties in any manner whatsoever.

Your Responsibilities

The above warranties are subject to the following conditions:

- (1) You must retain and present your dated invoice or bill of sale to provide proof of original purchase from an ADCOM Authorized Dealer and coverage during the warranty period.
- (2) All warranty servicing of this product must be done by an authorized ADCOM Service Center.
- (3) Charges by third parties for set-up, installation, de-installation, adjustments, shipment, insurance, and other charges are not covered by this warranty.
- (4) This warranty extends only to defects in material or workmanship as limited above and does not extend to any product or part which has been lost or discarded by you, or to damage to products or parts caused by misuse, accident, pets, Acts of God such as lightning or fluctuations in electrical power, improper installation, improper maintenance or use in violation of instructions provided in this Owner's Manual, or to products which have been altered or modified. This warranty does not extend to products which have had the serial number removed, altered, defaced, or rendered illegible.
- (5) Physical damage to the product from any cause is not covered by this warranty and the product will be returned as received without repair.

GFP-915 Specifications

Output Impedance	
Bypass/Main Outputs	100 Ohms
Tape Outputs	475 Ohms
Output Level	
Bypass/Main Outputs	2.0 Vrms
Rec Outputs	1.0 Vrms
Output Level(Maximum)	
Bypass/Main Outputs	10.0 Vrms
Frequency Response(± 0.5 dB)	
High Level	5Hz-100kHz
MM/MC	50Hz-50kHz
THD + Noise (@ rated output 20Hz - 20kHz)	
High Level	0.005%
MM	0.15%
MC	0.03%
Signal to Noise (@ rated output - A weighted)	
High Level	≥ 100 dB
MM/MC	≥ 95 dB
Input Impedance	
High Level	11K Ω
MM/MC	11K Ω
Input Sensitivity (@ rated output)	
High Level	500mV
MM	3.5mV
MC	25mV
RIAA accuracy (20Hz - 20kHz)	
Phono	± 0.25 dB
Tone Controls	
Bass(20Hz)	± 11.5 dB
Treble(20kHz)	± 8.5 dB
USB Input(Maximum support)	192K/24bit
Optical Input(Maximum Support)	192K/24bit
Bluetooth Version	Qualcomm 5.0

General

Power	120VAC- 230VAC —50/60Hz
Chassis Dimensions	3.46" (88mm) x 16.9" (430mm) x 13.2" (335mm)
Maximum Dimensions	4.13" (105mm) x 16.9" (430mm) x 14.3" (335mm)
Weight	15.7 lbs. (7kg)
Weight, Packed	20 lbs. (9.05 kg)

GFP-915 Serial Port Command Set

INTRODUCTION

The Adcom GFP-915 can be controlled via the serial RS-232 port. The serial port can be connected to a system controller, PC or 'dumb terminal' via a straight-through standard 9-pin serial port cable (MALE on one end and FEMALE on the other end). When using a PC, a terminal emulator program (e.g. HyperTerminal or ProComm), can be used to control the GFP-915.

The communications parameters should be set as follows:

9600 baud, 8 data bits, no parity, 1 stop bit and Flow Control: Hardware

GFP-915 COMMAND SET

COMMAND String Hexadecimal String ASCII

POWER ON 57,20,31,20,31,20,32<CR> W 1 1 2<CR>
POWER OFF 57,20,31,20,31,20,31<CR> W 1 1 1<CR>
POWER TOGGLE 57,20,31,20,31,20,33<CR> W 1 1 3<CR>
VOLUME UP 57,20,31,20,39,20,31<CR> W 1 9 1<CR>
VOLUME DOWN 57,20,31,20,39,20,32<CR> W 1 9 2<CR>
MUTE ON 57,20,31,20,31,30,20,32<CR> W 1 10 2<CR>
MUTE OFF 57,20,31,20,31,30,20,31<CR> W 1 10 1<CR>
MUTE TOGGLE 57,20,31,20,31,30,20,33<CR> W 1 10 3<CR>
POLARITY NORMAL (0) 57,20,31,20,32,20,31,33<CR> W 1 2 13<CR>
POLARITY INVERT (180) 57,20,31,20,32,20,31,34<CR> W 1 2 14<CR>
POLARITY TOGGLE 57,20,31,20,32,20,31,35<CR> W 1 2 15<CR>
TRIGGER ON 57,20,31,20,33,20,31<CR> W 1 3 1<CR>
TRIGGER OFF 57,20,31,20,33,20,32<CR> W 1 3 2<CR>
PHONO (INPUT 1) 57,20,31,20,32,20,36<CR> W 1 2 6<CR>
INPUT 2 57,20,31,20,32,20,37<CR> W 1 2 7<CR>
INPUT 3 57,20,31,20,32,20,38<CR> W 1 2 8<CR>
INPUT 4 57,20,31,20,32,20,38<CR> W 1 2 9<CR>
INPUT 5 57,20,31,20,32,20,31,30<CR> W 1 2 10<CR>
INPUT 6 57,20,31,20,32,20,31,31<CR> W 1 2 11<CR>
NEXT INPUT 57,20,31,20,32,20,34<CR> W 1 2 4<CR>
PREVIOUS INPUT 57,20,31,20,32,20,35<CR> W 1 2 5<CR>
TONE ON 57,20,31,20,34,20,31<CR> W 1 4 1<CR>
TONE OFF 57,20,31,20,34,20,32<CR> W 1 4 2<CR>

Please Note: "<CR>" stands for Carriage Return, the Hex Code is "0D". A space in Hex is "20", a space in ASCII is just a blank space (as shown above).