

# ➤ Instructions

Thule Tepui Low-Pro 2

Thule Tepui Low-Pro 3

901002, 901003



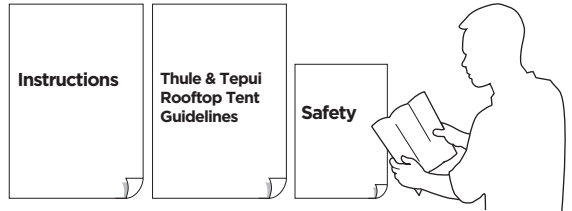

13 mm 10 mm

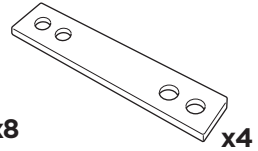
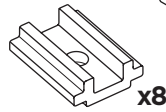
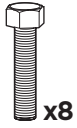

13 mm

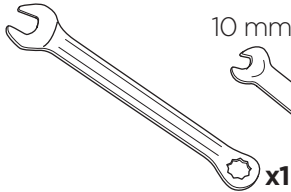

10 mm

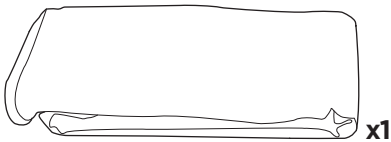
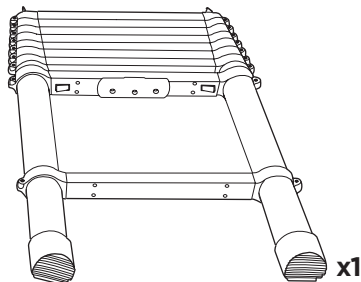
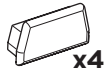
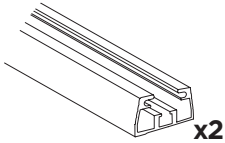
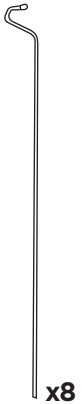
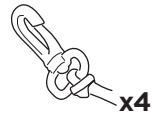
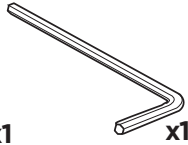
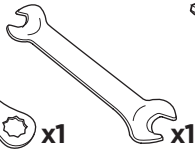

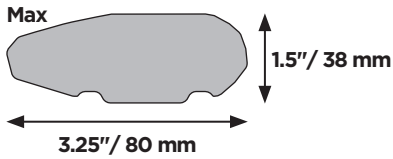

**Adapter** Thule Xsporter & Thule TracRac bar Xadapt 14

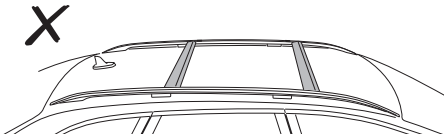
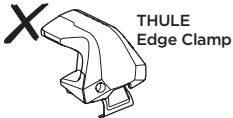
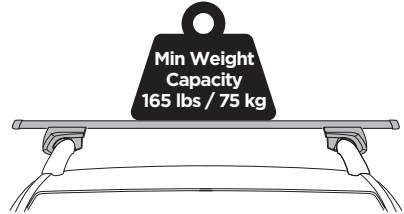
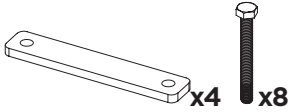

**DO NOT** use Tepui tents on factory installed crossbars.

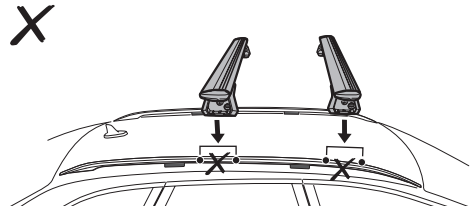
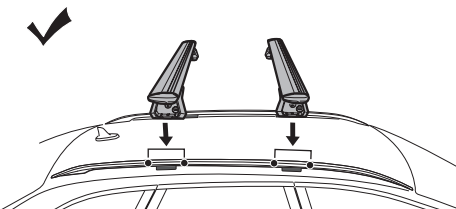
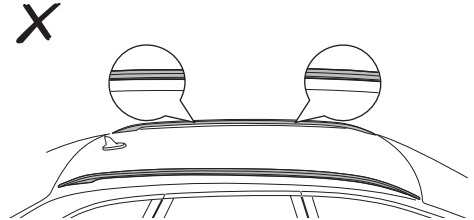
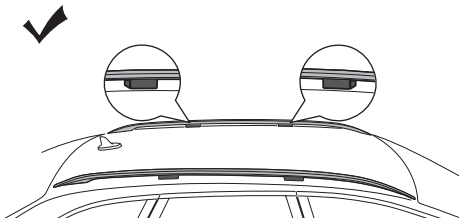
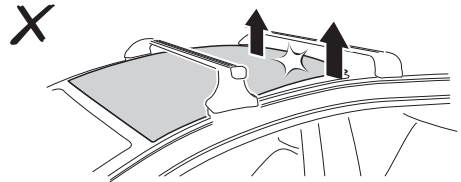

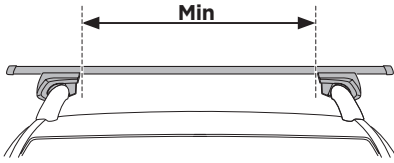

**Min 23.5"/60 cm**

**Min 32"/81 cm**

**THULE SquareBar Evo Max 50"/127 cm**

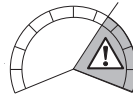
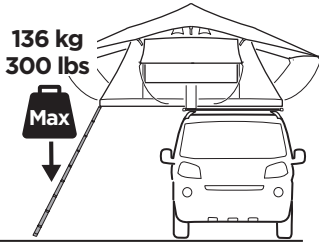

**Max 130 km/h  
80 Mph**

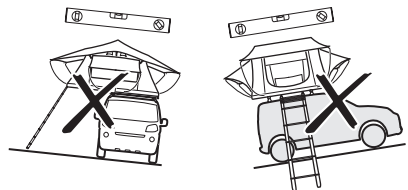
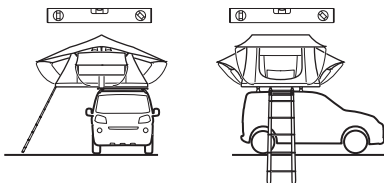
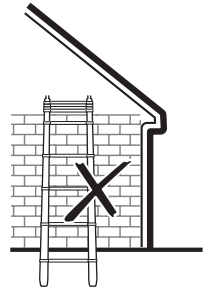
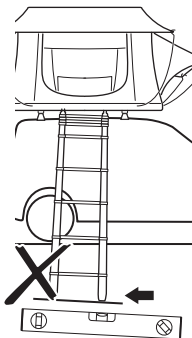
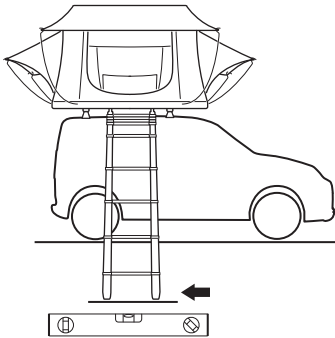

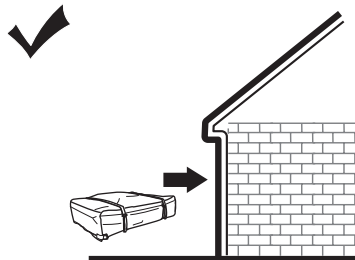
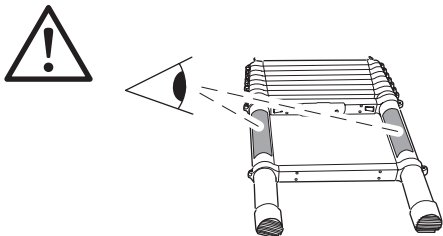
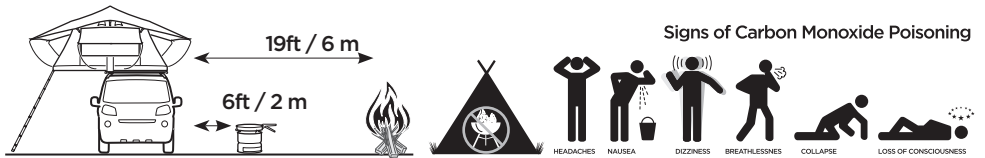
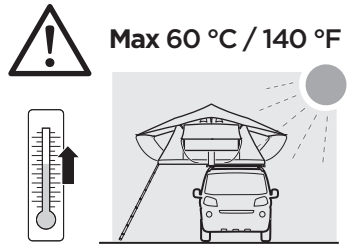
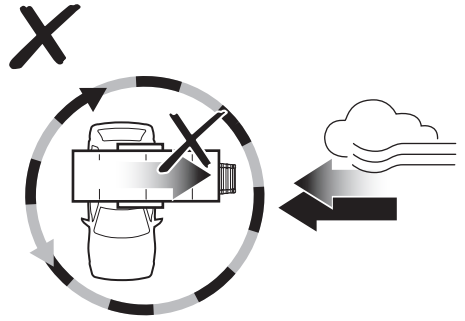
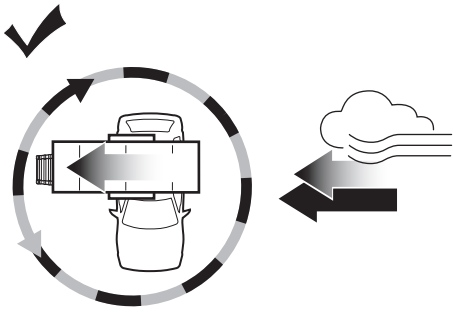

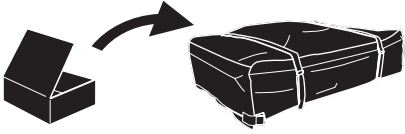

1

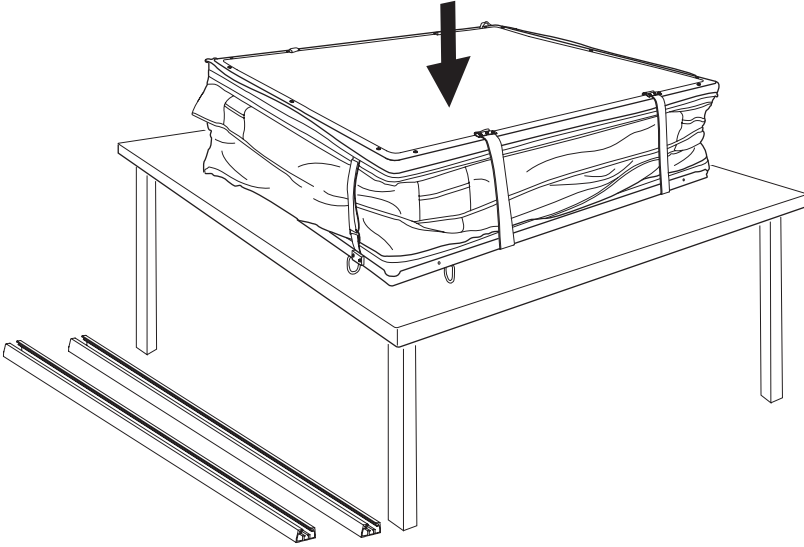

2

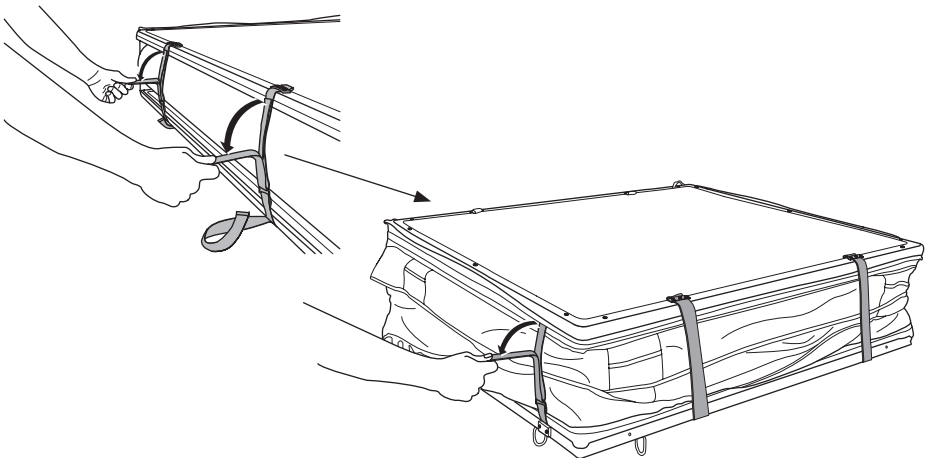

3

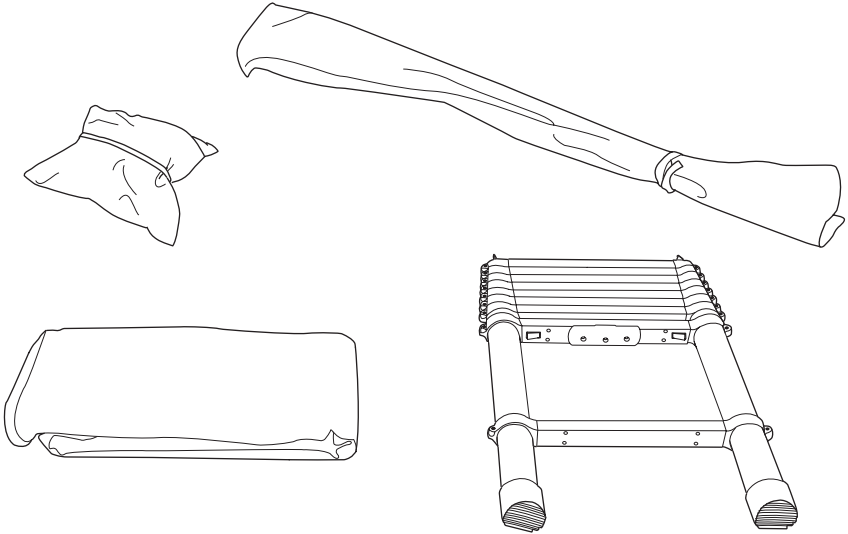
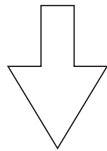
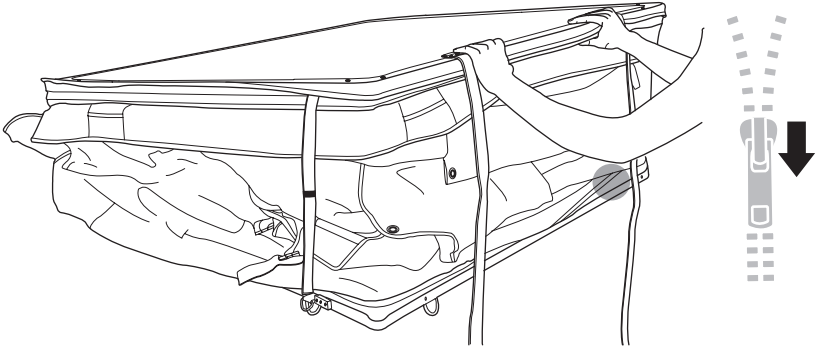

**i**

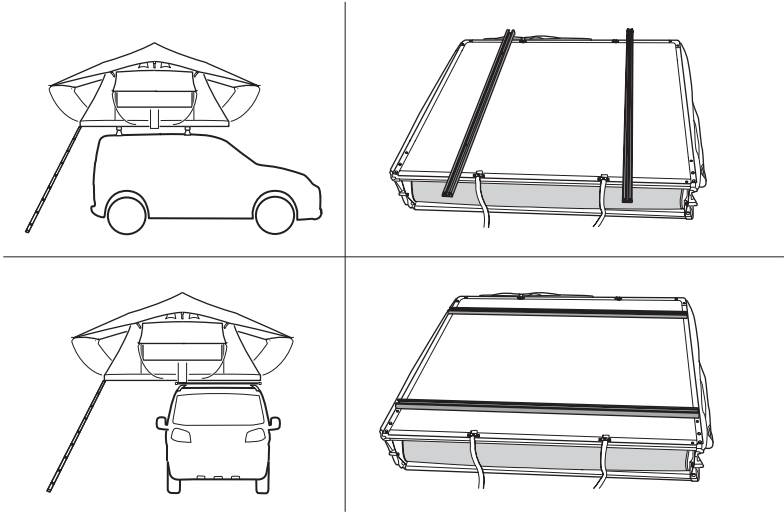

**4**

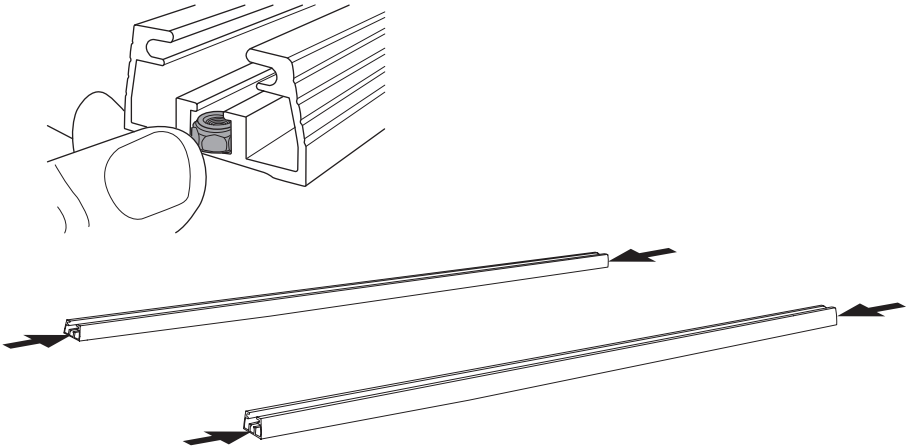
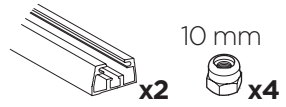



5

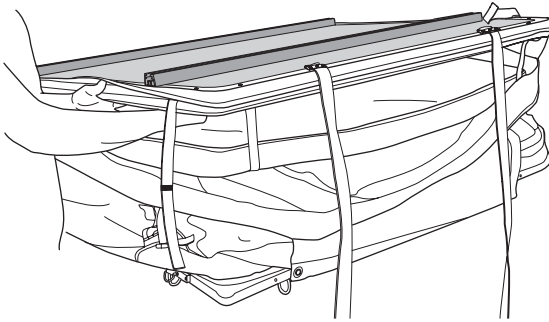

10 mm



x4

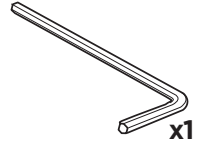

x1

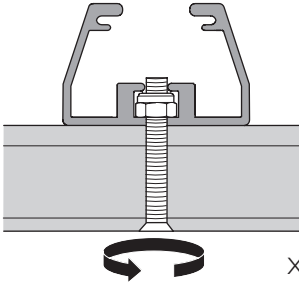

x4

x4

**i**

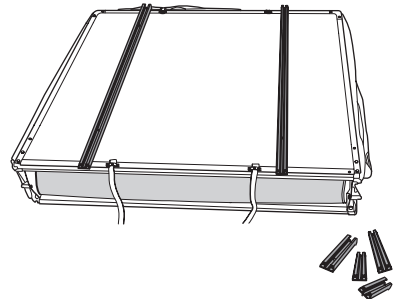
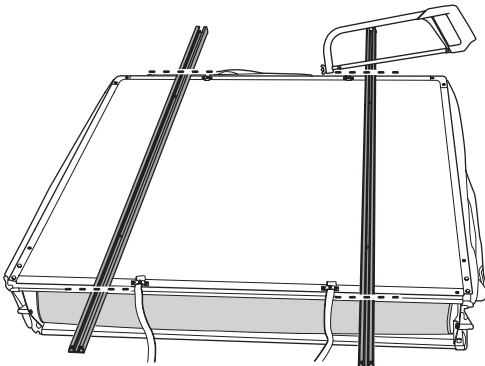
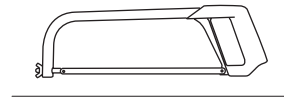
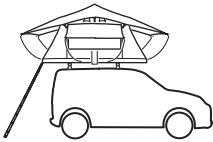

6

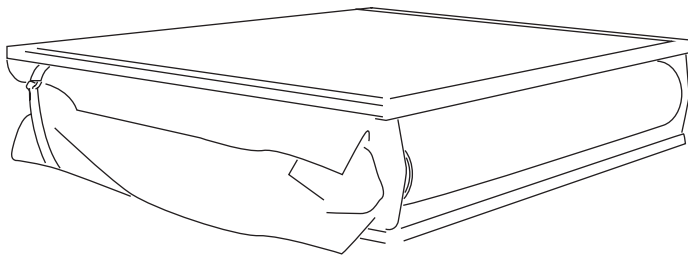
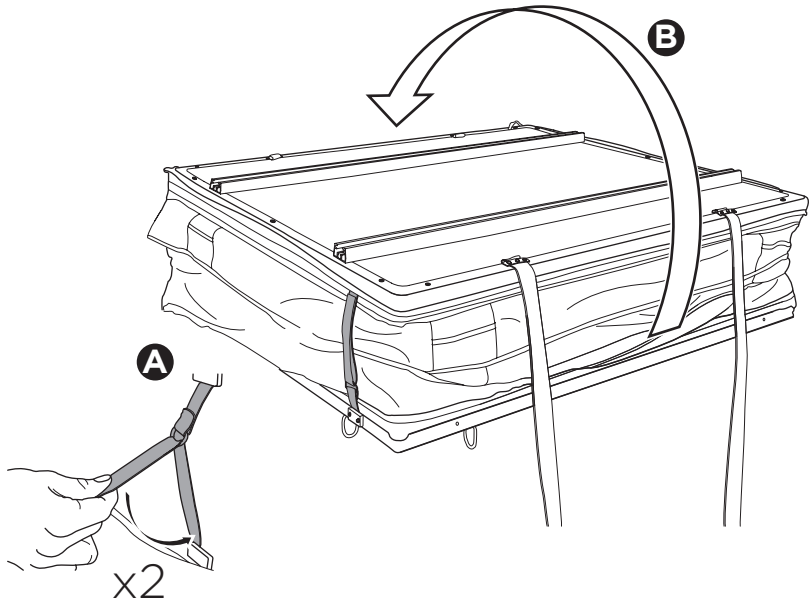

7

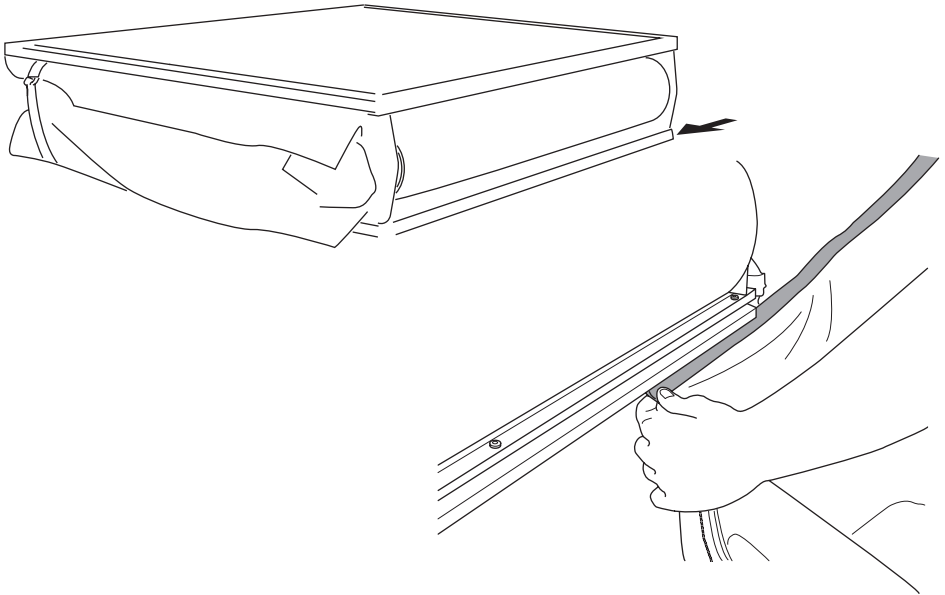

8

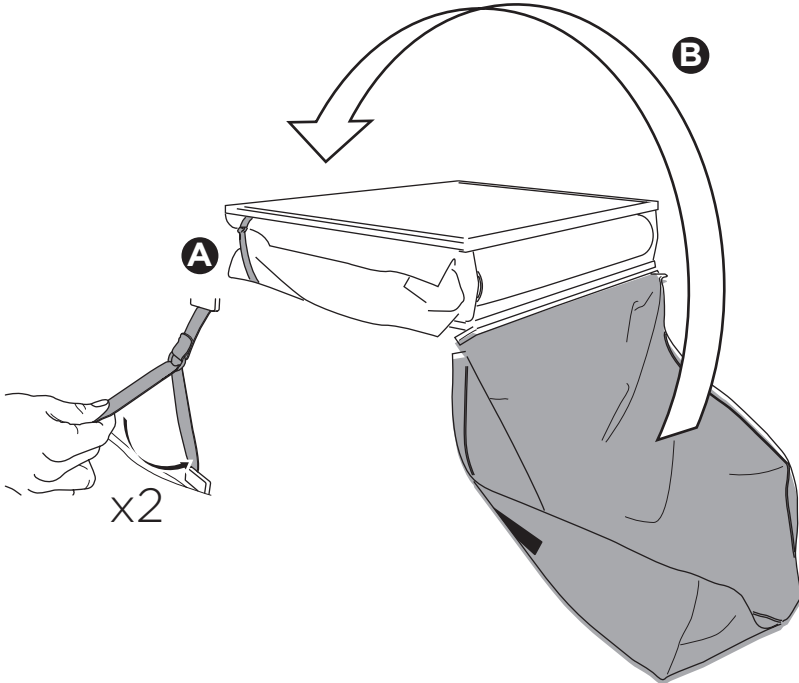

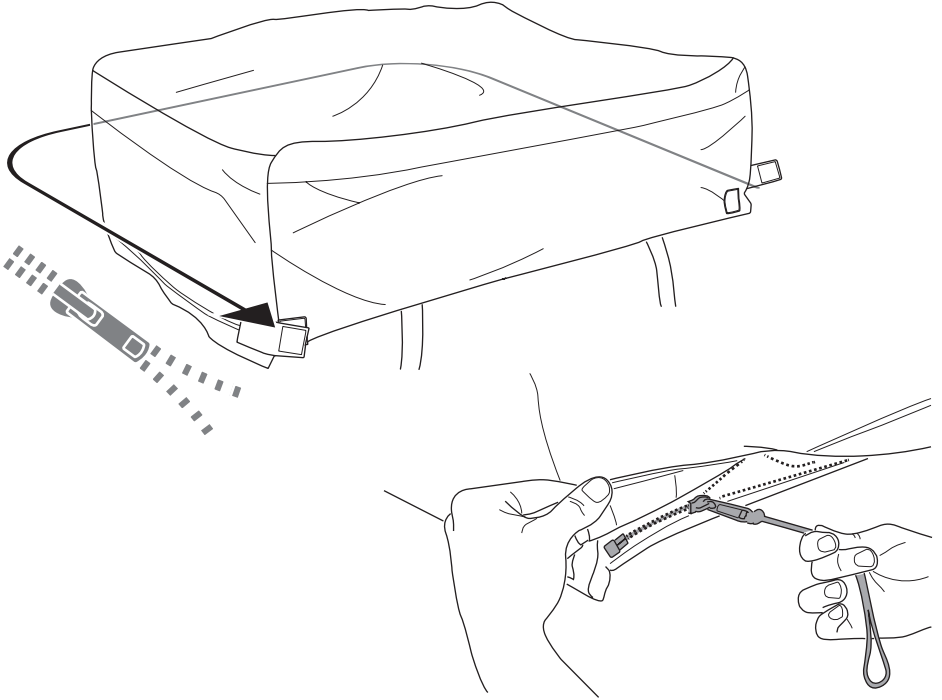

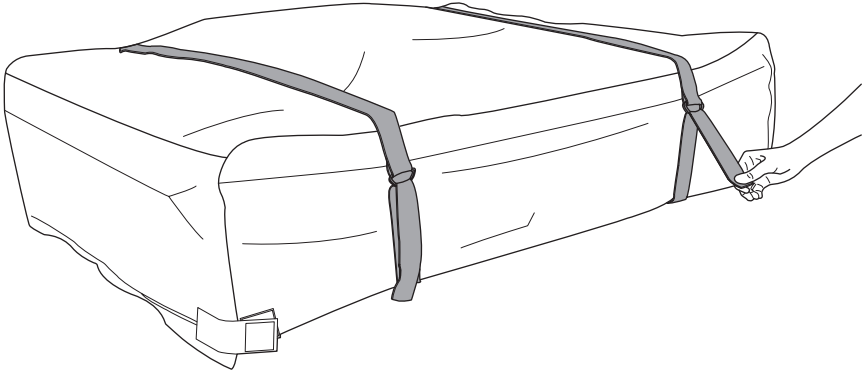



1

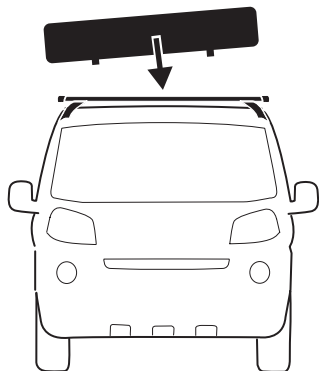

i

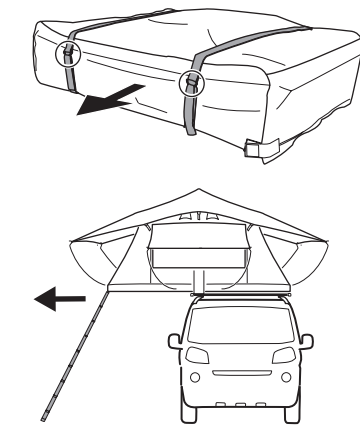

2

13 mm



x8

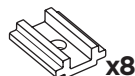

x8

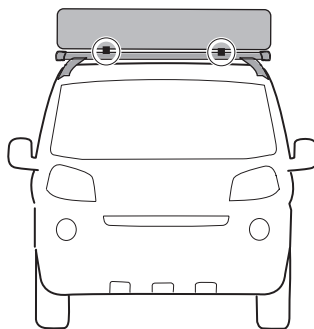
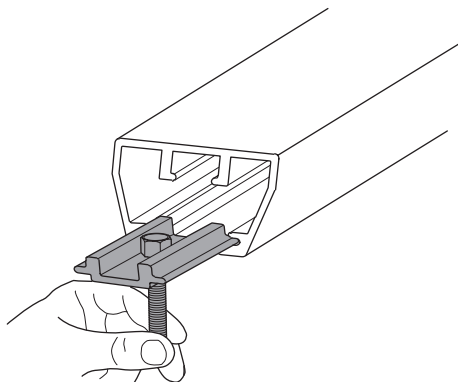

x8

3

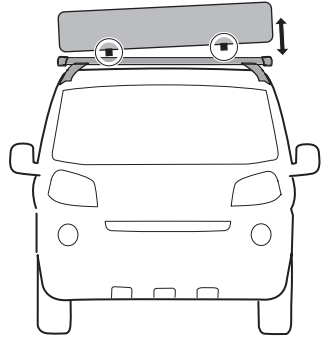
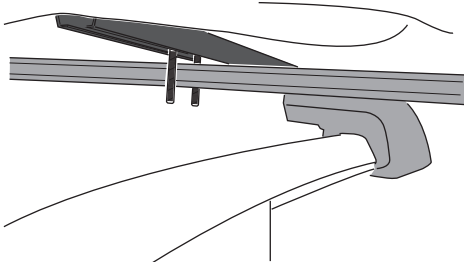

x4

4



x1

13 mm



x8

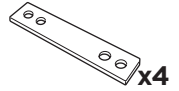

x4

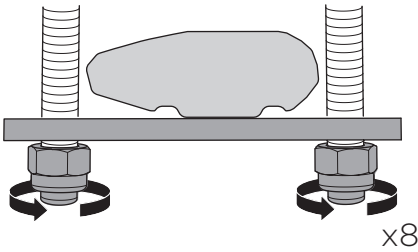

x8

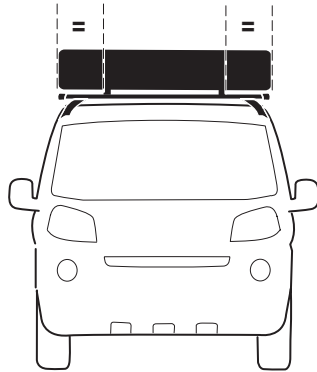

5

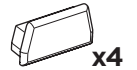
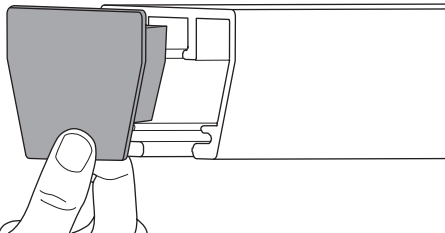

x4

x4

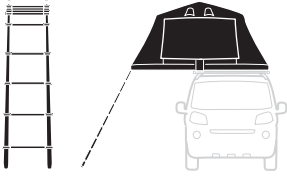

1

A

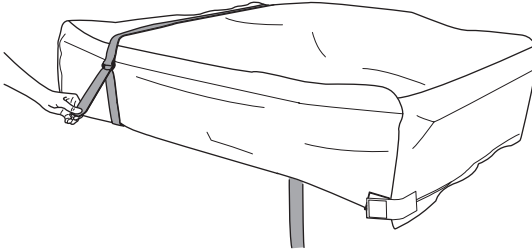

B

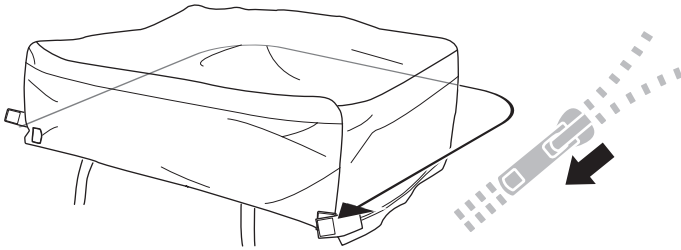

2

A

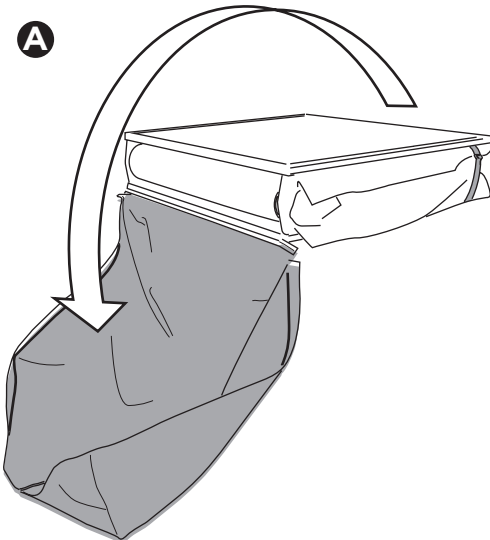

B

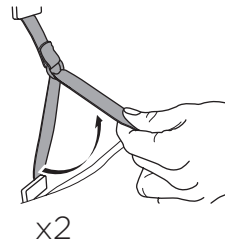



3

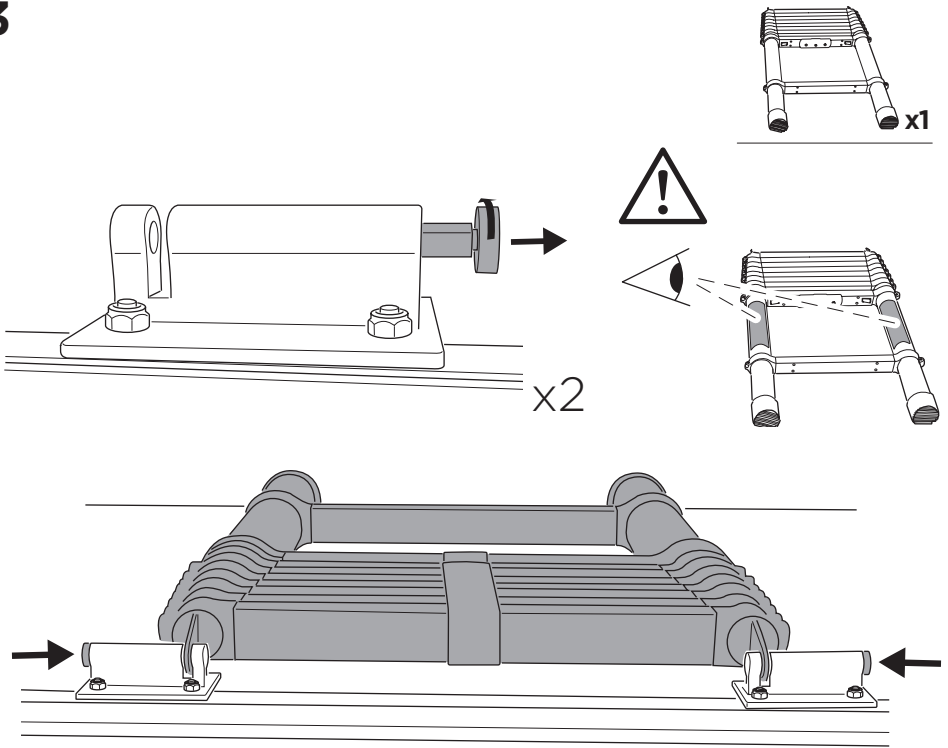

4

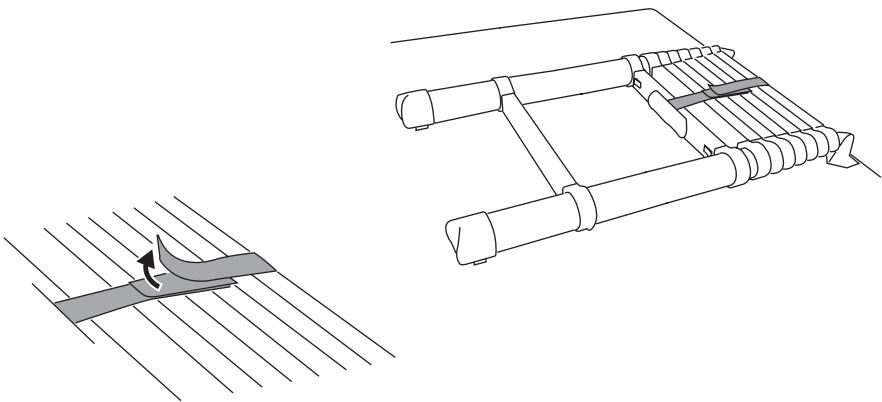

5

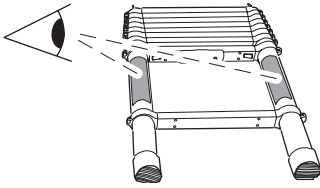

*click click click click click*

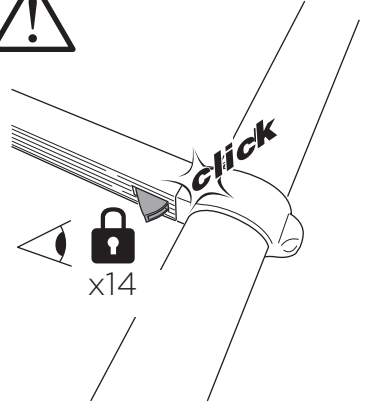
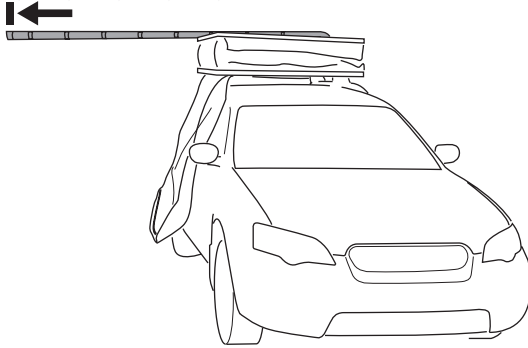

6

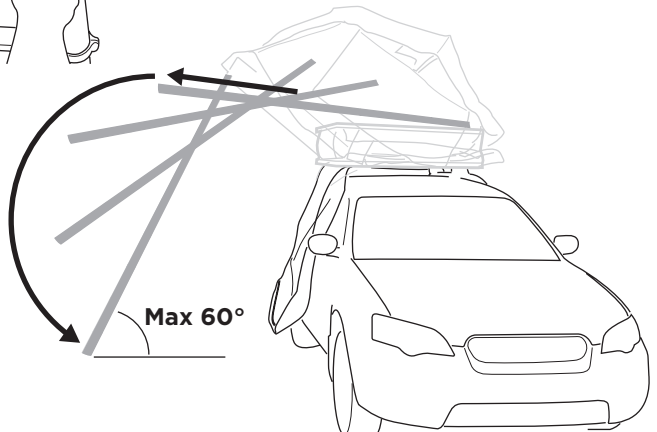
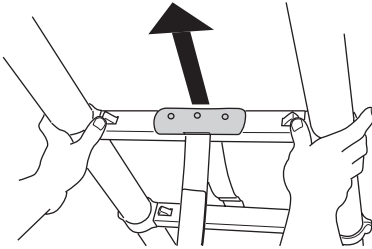

# 7

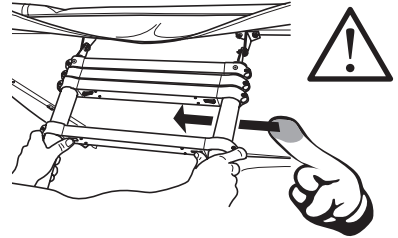
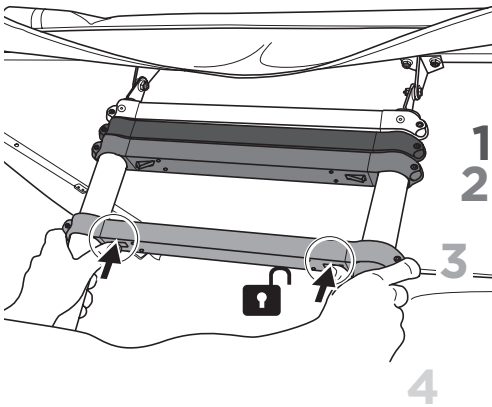
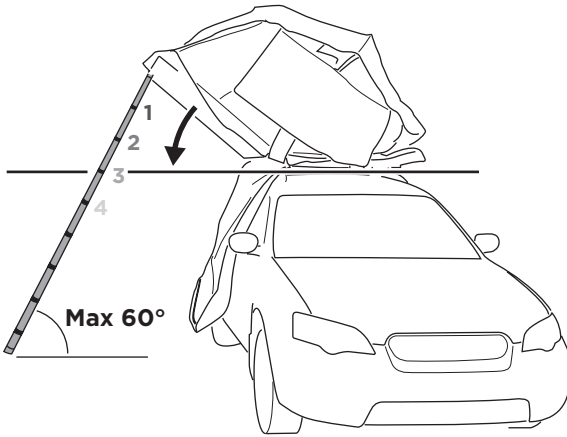

8

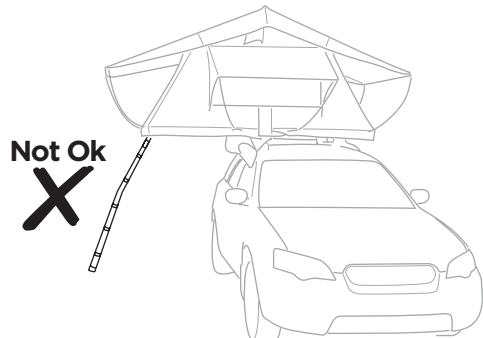
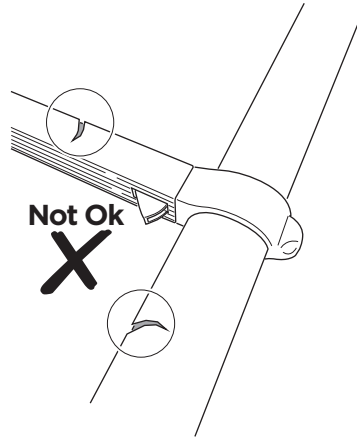
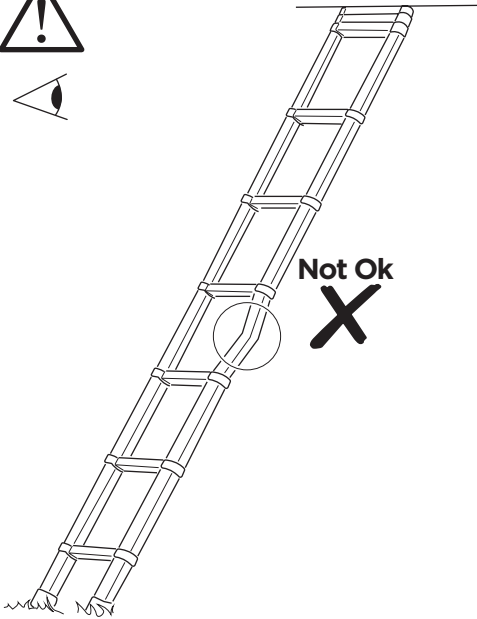
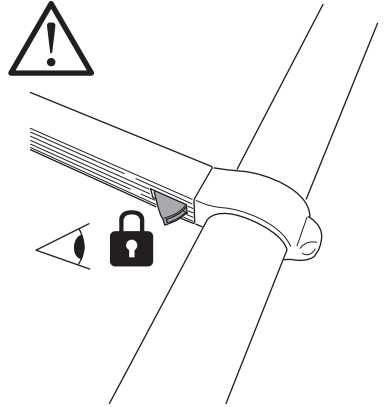
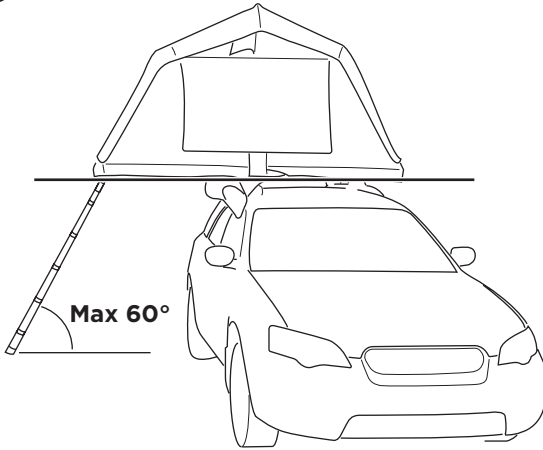

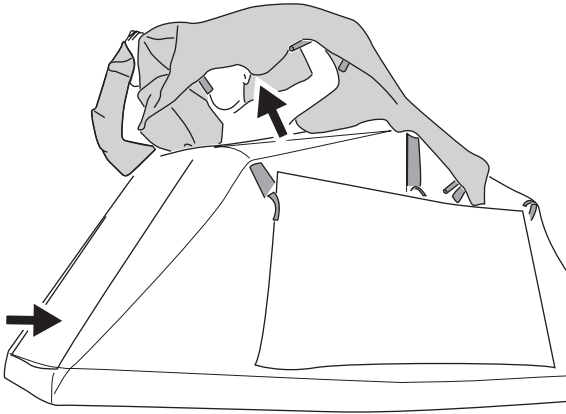
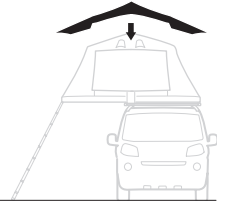

**A**

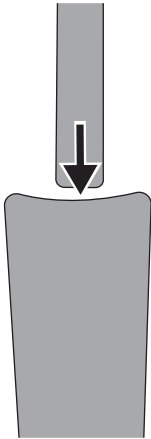

x6

**B**

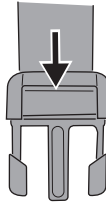

x6

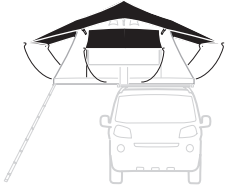

1

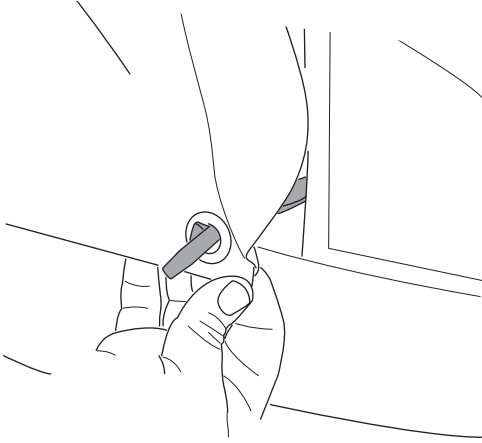

2

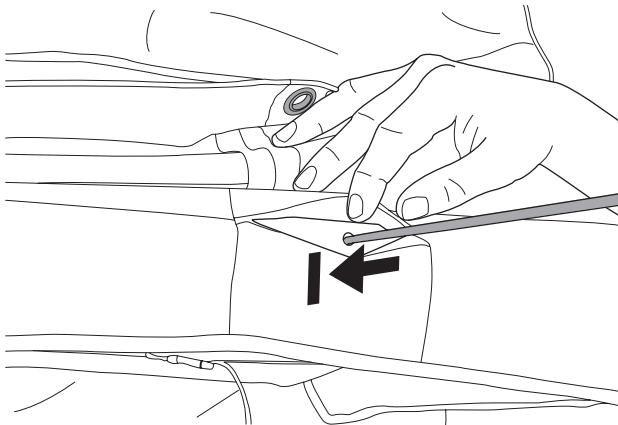

x8

**3**

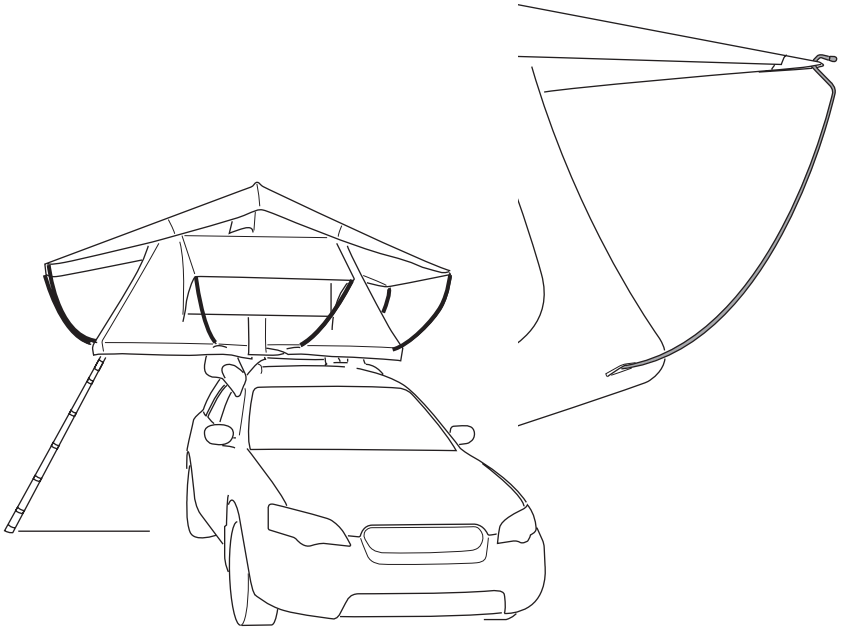

**4**

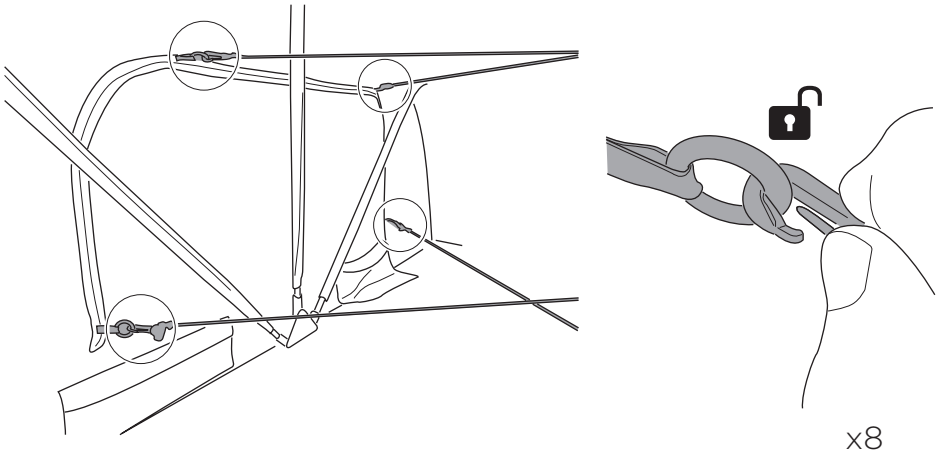

**i**

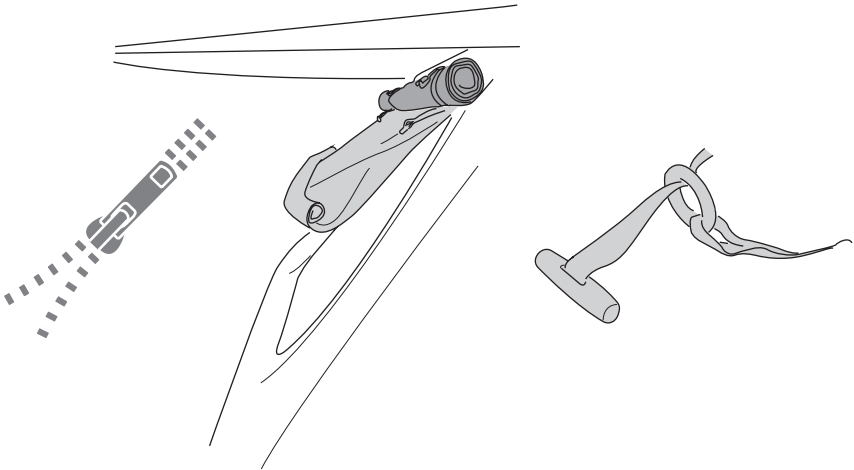
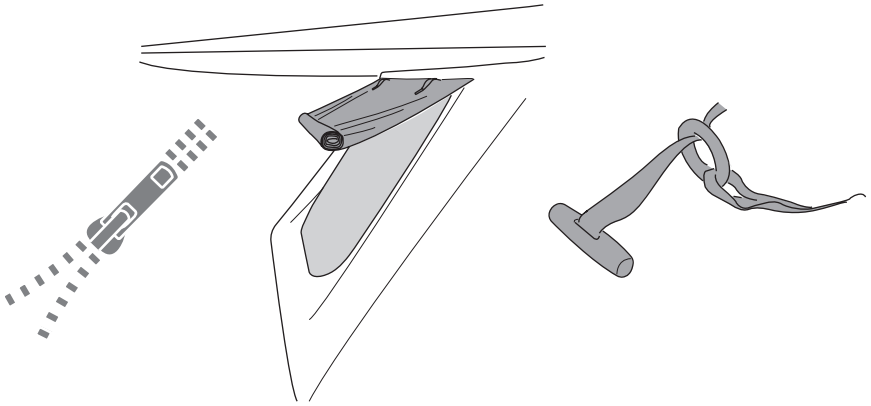

**i**

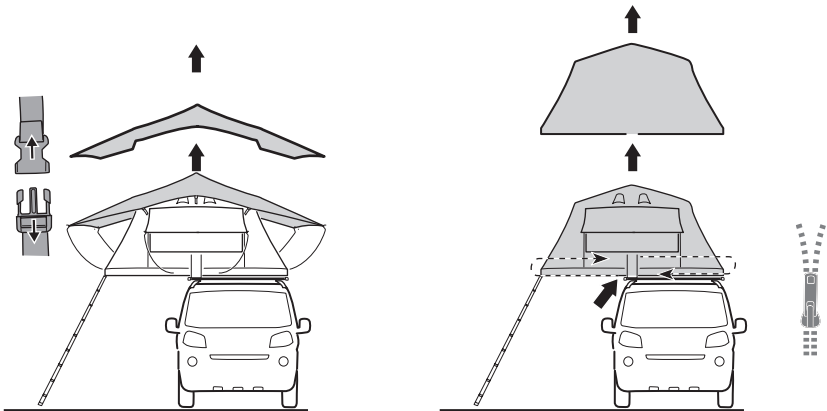





1

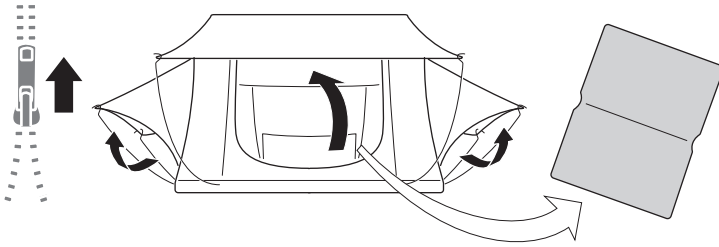

2

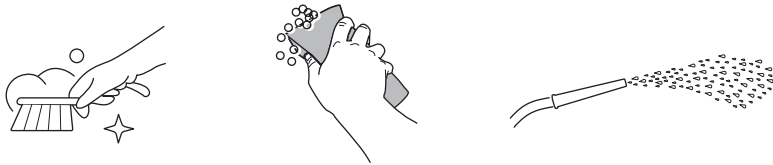

3

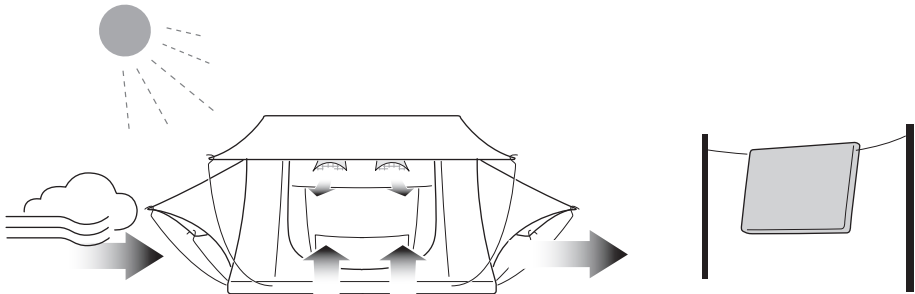

4

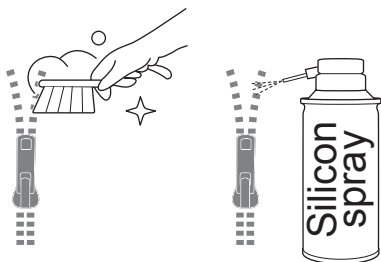



1

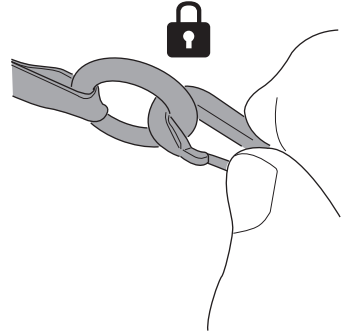
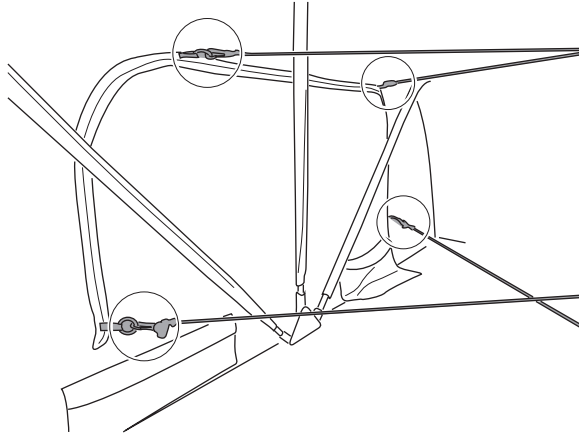

x8

2

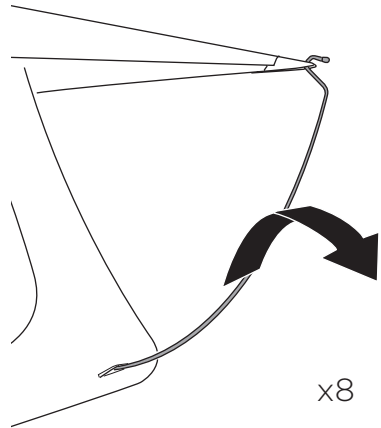
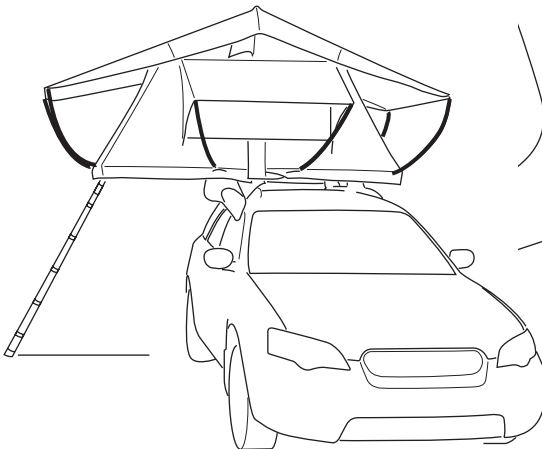

x8

# 3

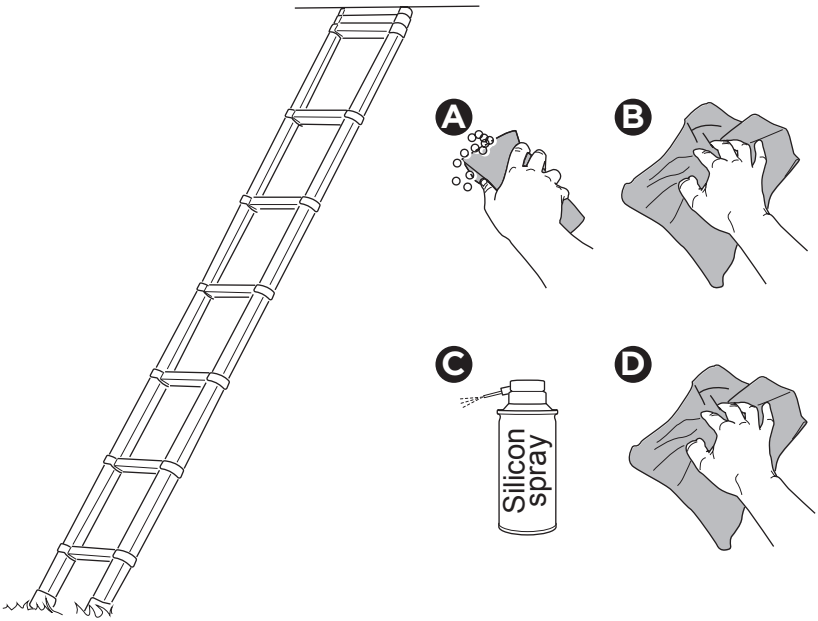

---

# 4

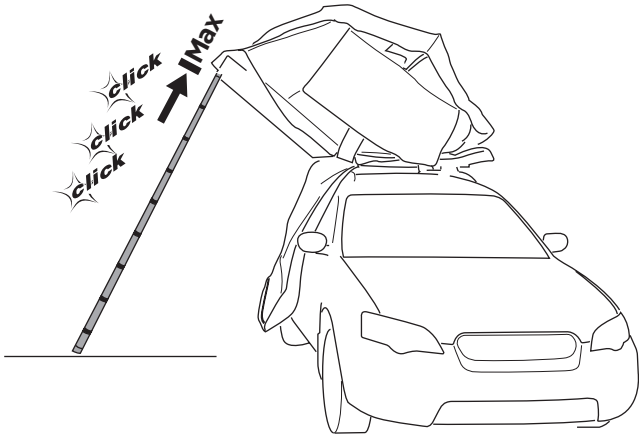

5

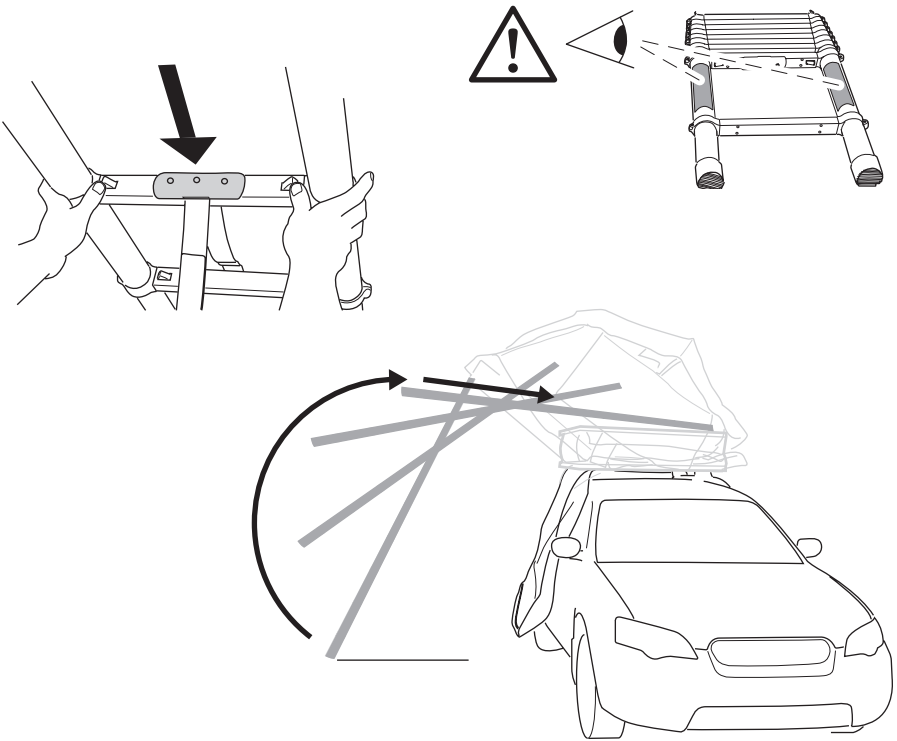

6

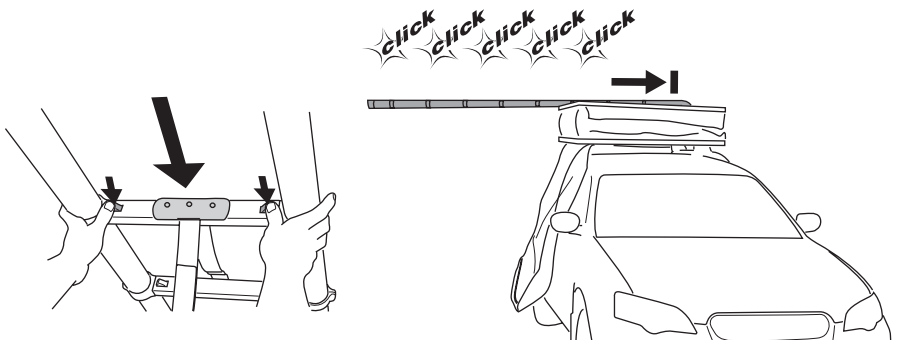

7

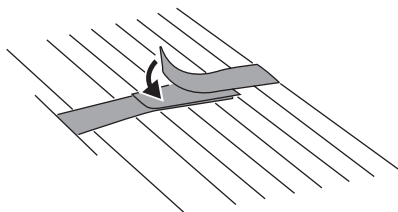
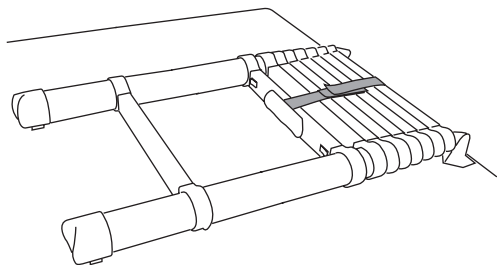

8

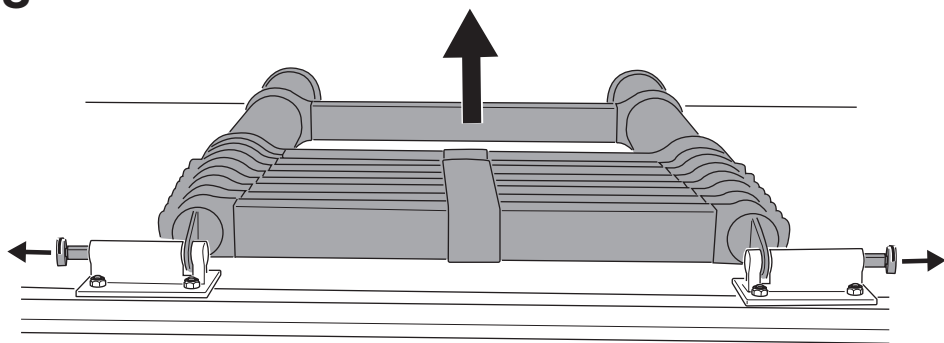

9

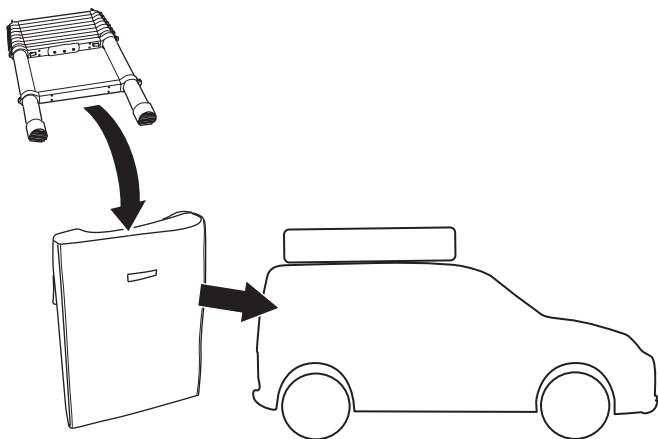

10

**A**

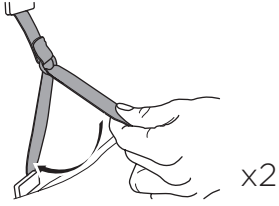

**B**

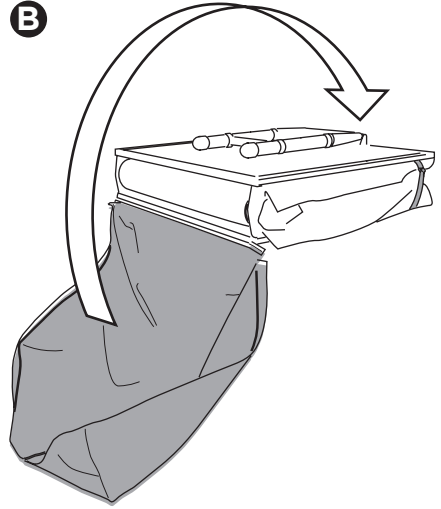

11

**A**

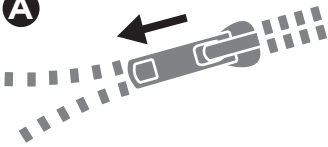

**B**

