



Vivere Outdoor Pty. Ltd.  
www.vivere.com.au

Vivere New Zealand Limited  
www.vivere.co.nz

Tel: 61 409 918 108  
customerserviceaud@vivereltd.com

### TERMS, CONDITIONS, and WARRANTY

#### Limited One Year Warranty

Vivere Ltd. ("Vivere") warrants that for a period of one (1) year from the date of original retail purchase, this product will be free from defects in material and workmanship. Vivere, at its option, will repair or replace this product or any component of the product found to be defective during the warranty period. Replacement will be made with a new or remanufactured product or component. If the product is no longer available, replacement may be made with a similar product of equal or greater value. This is your exclusive warranty.

This warranty is valid for the original retail purchaser from the date of initial retail purchase and is not transferable. Keep the original sales receipt. Proof of purchase is required to obtain warranty performance. Retailers selling Vivere products do not have the right to alter, modify or in any way change the terms and conditions of this warranty.

#### What This Warranty Does Not Cover

This warranty does not cover discoloration of product, damaged caused by mildew, mold or any external source. It does not cover normal wear of parts, or damage resulting from any of the following: negligent use of misuse of the product, commercial use of the product, use contrary to the assembly instructions, repair or alteration by anyone unless the service was authorized by Vivere. Further, the damage warranty does not cover acts of God, such as: fire, flood, hurricanes, tornadoes and any form of precipitation: (i.e., rain, snow, hail). Warranty void if damage to the product results from the use of a part other than a genuine Vivere part.

#### How to Obtain Warranty Service

Your product must be under warranty in order to obtain warranty service. If your product is defective and is within your warranty period, call us at +61 409 918 108 or email us at: customerserviceaud@vivereltd.com in order to receive a return authorization. Do not return product to Vivere without authorization. You will be directed to attach a tag to the product that includes your name, address, mobile telephone number and description of the problem. Include a copy of the original sales receipt. Carefully package the product and send insured by carrier of your choice prepaid to the warehouse address as directed by the Vivere Team.

For Products Purchased in  
**AUSTRALIA** contact:  
Vivere Outdoor Pty. Ltd.

For Products Purchased in  
**NEW ZEALAND** contact:  
Vivere New Zealand Limited

1. **Take Photos:** Take photos of the defective product(s)/part(s), clearly illustrating the problem area to support your claim.
2. **Attach Proof of Purchase:** Provide the original proof of purchase/sales receipt. Scan or provide a photo of the proof of purchase and submit it with your claim along with your full address, phone number, and a description of the issue.
3. **Submit via Email:** Email your claim to customerserviceaud@vivereltd.com
4. **Response:** A Vivere representative will correspond with you to resolve your claim as quickly as possible.

Thank-you for your interest in our products and we hope Vivere can inspire your outdoor living.  
Warmest Regards,

Jason Stoter, President, Vivere Limited



ASSEMBLY INSTRUCTIONS:  
STEEL BEAM STAND  
(13ft/375cm)

13BEAM

IMPORTANT, RETAIN FOR FUTURE REFERENCE: READ CAREFULLY

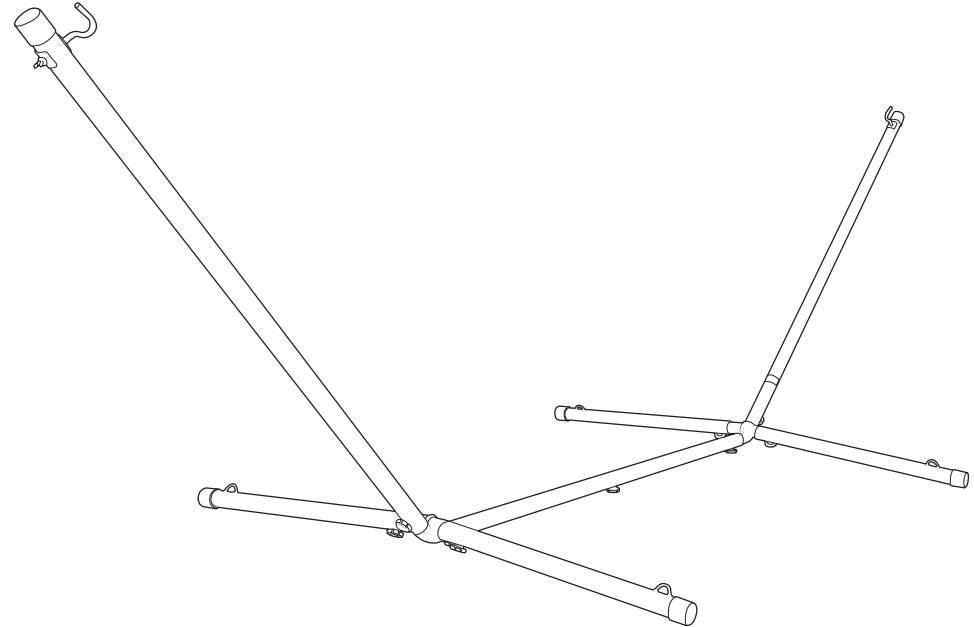

13BEAM.2023.AU.NZ

Vivere Outdoor Pty Ltd. • Vivere New Zealand Limited  
www.vivere.com.au • www.vivere.co.nz

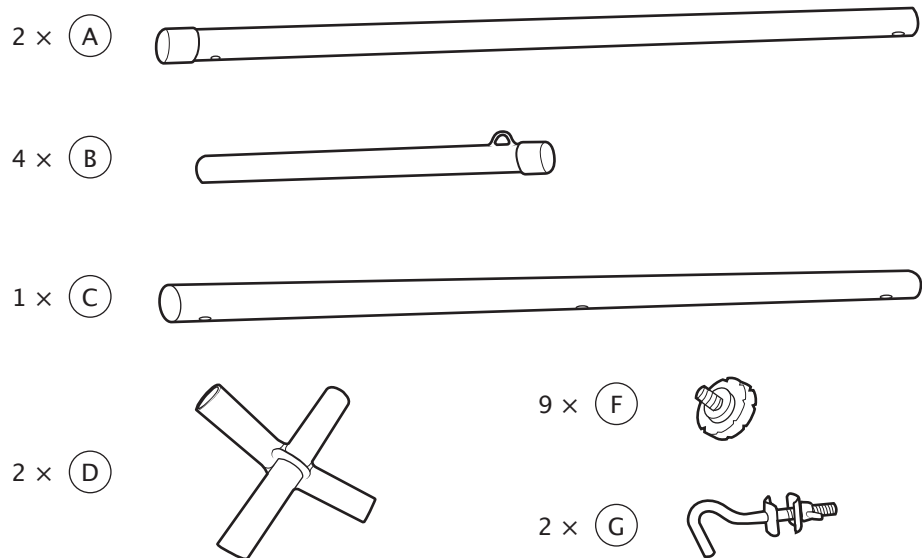

Ensure all parts are accounted for before proceeding with assembly.

**Also included in the 13BEAM package:**

Spare End Caps (Part E)

**Warnings:**

This product is intended for a maximum of 205 kg. Do not exceed weight capacity.  
 Do not stand on the product.  
 Only use and assemble on a clean, level surface. Ensure the frame remains in contact with the surface at all times.  
 Keep small parts out of reach of children.  
 Do not tighten bolts until fully assembled. Do not over tighten bolts.  
 Inspect and tighten all bolts regularly.  
 Do not use the product if parts are missing, damaged, or worn.

**Before Assembling:**

Unwrap all packaging materials  
 Ensure all parts listed are accounted for.  
 Ensure there is plenty of space, a clean, dry area for assembly, and all necessary tools are at hand.

**Care Instructions:**

To clean wipe with a clean, damp cloth and warm soapy water. Wipe dry with a dry, clean cloth.  
 Do not use solvent based cleaners as they can bleach or damage the product.  
 Never use scourers, abrasives, or chemical cleaners. Never use a pressure hose to wash the product.

We recommend furniture covers to protect your product when not in use. During inclement weather and winter months the product is to be stored in a cool, dry place. Before storage, ensure the product is clean and dry.  
 This frame is powder coated steel; when steel is exposed to air and moisture it will rust. To prevent corrosion, any scratches or damage to the paintwork should be touched up immediately with metal exterior paint.

