



## MODEL NUMBERS

**CL-RAC10EWES** – 10,000 BTU WINDOW AIR CONDITIONER  
**CL-RAC10EWES-6A** – 10,000 BTU WINDOW AIR CONDITIONER  
**CL-RAC12EWES** – 12,000 BTU WINDOW AIR CONDITIONER  
**CL-RAC12EWES-6A** – 12,000 BTU WINDOW AIR CONDITIONER

## OPERATING INSTRUCTIONS



**BEFORE RETURNING UNIT TO THE STORE**

**READ ALL QUESTIONS ON OPERATION AND WARRANTY**

**PLEASE VISIT OUR WEBSITE AT [WWW.COOLLIVINGPRODUCTS.COM](http://WWW.COOLLIVINGPRODUCTS.COM) CALL 1-800-752-5262 OR EMAIL [CUSTOMERSERVICE@1KMS.COM](mailto:CUSTOMERSERVICE@1KMS.COM)**

**PRODUCT REGISTRATION CARD MUST BE COMPLETED ONLINE OR COMPLETE AND MAIL THE ATTACHED REGISTRATION CARD TO**

**KMS INC. ATTN: CUSTOMER SERVICE, 811 E WATERMAN, WICHITA, KS 67202**



## **INTRODUCTION**

IMPORTANT SAFETY INSTRUCTIONS .....	1
ELECTRICAL REQUIREMENTS .....	2
PACKING LIST .....	4
INSTALLATION & ASSEMBLY INSTRUCTIONS .....	5
USING YOUR AIR CONDITIONER .....	10
CARE AND CLEANING .....	13
TROUBLESHOOTING .....	14
WARRANTY .....	15
REGISTRATION CARD .....	16

## IMPORTANT SAFETY INSTRUCTIONS

BEFORE INSTALLING AND USING YOUR AIR CONDITIONER, PLEASE READ THIS OWNER'S MANUAL CAREFULLY. STORE THIS MANUAL IN A SAFE PLACE FOR FUTURE REFERENCE. YOUR SAFETY AND THE SAFETY OF OTHERS IS VERY IMPORTANT. PLEASE PAY ATTENTION TO ALL SAFETY MESSAGES OUTLINED IN THIS OWNER'S MANUAL.

**WARNING:** TO REDUCE THE RISK OF FIRE, ELECTRICAL SHOCK OR INJURY WHEN USING YOUR AIR CONDITIONER, FOLLOW THE FOLLOWING BASIC PRECAUTIONS:

- \*PLUG INTO A GROUNDED 3 PRONG OUTLET.
- \*DO NOT USE AN EXTENSION CORD.
- \*DO NOT REMOVE THE GROUND PRONG.
- \*UNPLUG THE AIR CONDITIONER BEFORE SERVICING
- \*DO NOT USE A PLUG ADAPTER.
- \*USE TWO OR MORE PEOPLE TO MOVE & INSTALL THE AIR CONDITIONER.



THIS IS A SAFETY ALERT SYMBOL.

THIS SYMBOL ALERTS YOU TO POTENTIAL HAZARDS THAT CAN HARM YOU OR OTHERS OR EVEN CAUSE DEATH.

ALL SAFETY MESSAGES WILL DIRECTLY FOLLOW THE SAFETY ALERT SYMBOL AND/OR THE WORDS "**DANGER**" OR "**WARNING**".

**⚠ DANGER**

**⚠ WARNING**

FAILURE TO IMMEDIATELY FOLLOW THESE INSTRUCTIONS MAY CAUSE SERIOUS INJURY OR EVEN DEATH.

ALL SAFETY MESSAGES ALERT YOU OF POTENTIAL HAZARDS, HOW TO REDUCE THE CHANGE OF INJURY, AND WHAT CAN HAPPEN IF INSTRUCTIONS ARE NOT FOLLOWED CORRECTLY.

FCC Caution.

This device complies with part 15 of the FCC Rules. Operation is subject to the following two conditions: (1) This device may not cause harmful interference, and (2) this device must accept any interference received, including interference that may cause undesired operation.

Any Changes or modifications not expressly approved by the party responsible for compliance could void the user's authority to operate the equipment.

## **ELECTRICAL REQUIREMENTS**

### **⚠ WARNING**



#### **Electrical Shock Hazard**

Plug into a grounded 3 prong outlet.  
Do not remove the ground prong.  
Do not use an adapter  
Do not use an extension cord.  
Failure to follow these instructions can result in death, fire, or electrical shock

THE ELECTRICAL RATINGS FOR YOUR AIR CONDITIONER ARE LISTED ON THE MODEL AND SERIAL NUMBER LABEL ON THE FRONT LEFT SIDE OF THE UNIT (WHEN FACING THE FRONT).

SPECIFIC ELECTRICAL REQUIREMENTS ARE LISTED IN THE CHART BELOW. FOLLOW THE REQUIREMENTS BELOW FOR THE TYPE OF PLUG ON THE POWER SUPPLY CORD.

#### **WIRING REQUIREMENTS**

- \* 115 VOLT (103 MIN. -127 MAX)
- \* (6K-8K) 0-8 AMPS
- \* (6K-8K) 10-AMP TIME-DELAY FUSE OR CIRCUIT BREAKER
- \* (10K-12K) 15-AMP TIME-DELAY FUSE OR CIRCUIT BREAKER
- \* USE ON SINGLE OUTLET CIRCUIT ONLY

#### **POWER SUPPLY CORD**



### **RECOMMENDED GROUND METHOD**

FOR YOUR PERSONAL SAFETY, THIS AIR CONDITIONER MUST BE GROUNDED. THIS AIR CONDITIONER IS EQUIPPED WITH A 3 PRONG POWER SUPPLY CORD WITH A GROUNDED PLUG. TO MINIMIZE THE POSSIBILITY OF ELECTRICAL SHOCK, THE CORD MUST BE PLUGGED INTO A 3 PRONG OUTLET AND GROUNDED IN ACCORDANCE WITH ALL LOCAL CODES AND ORDINANCES. IF A 3 PRONG OUTLET IS NOT AVAILABLE, IT IS THE CUSTOMER'S RESPONSIBILITY TO HAVE A PROPERLY GROUNDED 3 PRONG OUTLET INSTALLED BY A QUALIFIED ELECTRICIAN.

### **IT IS THE CUSTOMER'S RESPONSIBILITY:**

- \*TO CONTACT A QUALIFIED ELECTRICIAN
- \*TO ASSURE THAT THE ELECTRICAL INSTALLATION IS ADEQUATE AND IN CONFORMANCE WITH THE NATIONAL ELECTRICAL CODE, ANSI/NFPA 70 – LATEST EDITION, AND ALL LOCAL CODES AND ORDINANCES.

### **COPIES OF THE STANDARDS LISTED MAY BE OBTAINED FROM:**

NATIONAL FIRE PROTECTION ASSOCIATION  
ONE BATTERY MARCH PARK  
QUINCY, MASSACHUSETTS 02269

## **ELECTRICAL REQUIREMENTS (CONT.)**

### **LCDI POWER CORD AND PLUG**

THIS AIR CONDITIONER IS EQUIPPED WITH AN LCDI (LEAKAGE CURRENT DETECTION AND INTERRUPTION) POWER CORD AND PLUG AS REQUIRED BY US NATIONAL ELECTRIC CODE 440.65. THIS POWER SUPPLY CORD CONTAINS STATE-OF-THE ART ELECTRONICS THAT SENSE LEAKAGE CURRENT. IF THE CORD IS DAMAGED AND LEAKAGE OCCURS, POWER WILL BE DISCONNECTED FROM THE UNIT.

THE TEST AND RESET BUTTONS ON THE LCDI PLUG ARE USED TO CHECK IF THE PLUS IS FUNCTIONING PROPERLY. TO TEST THE PLUG:

1. PLUG POWER CORD INTO A GROUNDED 3 PRONG OUTLET
2. PRESS RESET (ON SOME UNITS A GREEN LIGHT WILL TURN ON).
3. PRESS THE TEST BUTTON, THE CIRCUIT SHOULD TRIP AND CUT ALL POWER TO THE AIR CONDITIONER. (ON SOME UNITS A GREEN LIGHT MAY TURN OFF).
4. PRESS THE RESET BUTTON FOR USE. YOU WILL HEAR A CLICK AND THE A/C IS NOW READY FOR USE.







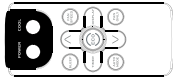
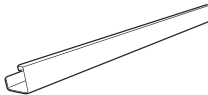
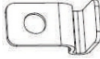

#### **NOTES:**

- \*THE RESET BUTTON MUST ENGAGE FOR PROPER USE.
- \*THE POWER SUPPLY CORD MUST BE REPLACED IF IT FAILS TO TRIP WHEN THE TEST BUTTON IS PRESSED AND THE UNIT FAILS TO RESET.
- \*DO NOT USE THE POWER SUPPLY CORD AS AN ON/OFF SWITCH. THE POWER SUPPLY CORD IS DESIGNED AS A PROTECTION DEVICE.
- \*A DAMAGED POWER SUPPLY CORD MUST BE REPLACED WITH A NEW POWER SUPPLY CORD.
- \*THE POWER SUPPLY CONTAINS NEW USER SERVICEABLE PARTS. OPENING THE TAMPER-RESISTANT CASE VOIDS ALL WARRANTY AND PERFORMANCE CLAIMS.
- \*YOUR UNITS POWER CORD AND PLUG MAY DIFFER FROM THE ONE SHOWN.

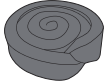
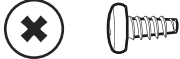
## PACKING LIST

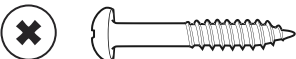
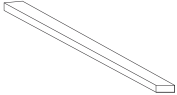
(APPEARANCE MAY VARY)

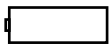
IMAGE	PART	QUANTITY
	Window Air Conditioner	1
	Remote Control	1
	Top Mounting Rail (With sponge)	1
	Lock Frame	2
	Filler Panels (With "Left" & "Right" remark on the front face)	2
	Sash Lock(Two holes)	1
	Window Sash Seal (Sponge)	1
	3/8" Screws	4
	1/2" Screws	3
	3/4" Screws	4
	Foam Top Window Gasket (Thin sponge for back-up using)	1
	Insulation strip(Sponge)	2
	Battery	2

### DISCLAIMER

ALL INFORMATION AND THE TECHNICAL SPECIFICATIONS PRESENTED IN THIS OWNER'S MANUAL ARE THE PRESENTATION OF THE MANUFACTURER. KMS HAS NOT CONDUCTED AN INDEPENDENT TEST TO THE INFORMATION AND THE SPECIFICATIONS PRESENTED HERE WITHIN.

## **INSTALLATION & ASSEMBLY INSTRUCTIONS (FOR 6K/8K UNIT)**

SOME ASSEMBLY IS REQUIRED FOR YOUR NEW AIR CONDITIONER. PLEASE READ AND FOLLOW THESE INSTRUCTIONS CAREFULLY.

1. THE AIR CONDITIONER IS DESIGNED TO BE INSTALLED IN A STANDARD DOUBLE-HUNG WINDOW WITH A WINDOW WIDTH BETWEEN 23" AND 36" (584 MM – 914 MM).
2. THE AIR CONDITIONER CAN BE INSTALLED WITHOUT THE ACCORDION PANELS TO FIT IN A NARROW WINDOW OPENING. (SEE THE WINDOW DIMENSIONS).
3. THE LOWER SASH (THE LOWER PART OF THE WINDOW THAT MOVES UP AND DOWN) MUST ALLOW FOR 14.5" OF VERTICAL CLEARANCE WHEN OPEN. (SEE FIG. 1).
4. ALL SUPPORTING PARTS MUST BE SECURED TO FIRM WOOD, MASONRY OR METAL.
5. THE ELECTRICAL OUTLET MUST BE WITHIN REACH OF THE POWER CORD.

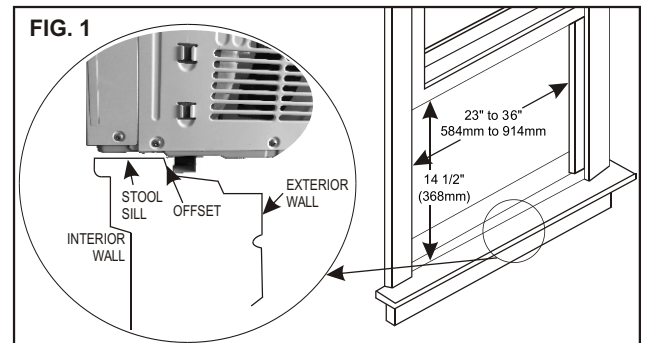

**NOTE:** SAVE THE PRODUCT PACKAGING & INSTALLATION INSTRUCTION FOR FUTURE REFERENCE. STORE THE AIR CONDITIONER IN THE PRODUCT BOX WHEN NOT IN USE FOR AN EXTENDED PERIOD OF TIME.

## **INSTALLATION & ASSEMBLY INSTRUCTIONS (FOR 10K/12K UNIT)**

1. THE AIR CONDITIONER IS DESIGNED TO BE INSTALLED IN A STANDARD DOUBLE-HUNG WINDOW WITH A WINDOW WIDTH BETWEEN 26" AND 36" (660 MM – 914 MM).
2. THE AIR CONDITIONER CAN BE INSTALLED WITHOUT THE ACCORDION PANELS TO FIT IN A NARROW WINDOW OPENING. (SEE THE WINDOW DIMENSIONS).
3. THE LOWER SASH (THE LOWER PART OF THE WINDOW THAT MOVES UP AND DOWN) MUST ALLOW FOR 16" OF VERTICAL CLEARANCE WHEN OPEN. (SEE FIG. 2).
4. ALL SUPPORTING PARTS MUST BE SECURED TO FIRM WOOD, MASONRY OR METAL.
5. THE ELECTRICAL OUTLET MUST BE WITHIN REACH OF THE POWER CORD.

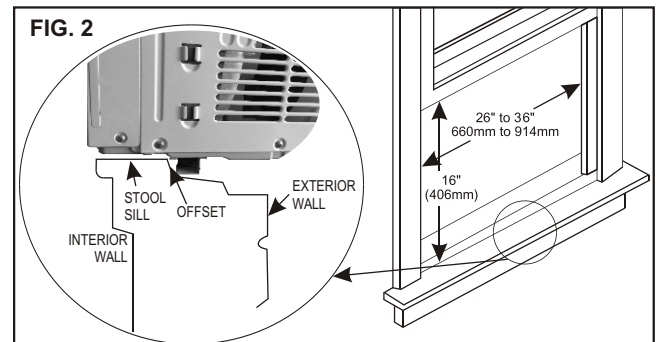

**NOTE:** SAVE THE PRODUCT PACKAGING & INSTALLATION INSTRUCTION FOR FUTURE REFERENCE. STORE THE AIR CONDITIONER IN THE PRODUCT BOX WHEN NOT IN USE FOR AN EXTENDED PERIOD OF TIME.





## INSTALLATION & ASSEMBLY INSTRUCTIONS

### TOP RAIL ASSEMBLY (ONLY USED FOR 6K/8K UNITS)

THE TOP RAIL MUST BE ASSEMBLED PRIOR TO INSTALLING THE AIR CONDITIONER IN THE WINDOW.

**TOOLS NEEDED:** PHILLIPS SCREW DRIVER

Top Rail Hardware		QTY
	3/8" Screw	4
	Top Rail	1

### ATTACHING THE TOP RAIL TO THE AIR CONDITIONER

1. REMOVE THE AIR CONDITIONER FROM THE BOX AND PLACE ON A HARD FLAT SURFACE.
2. REMOVE TOP RAIL FROM THE TOP OF THE PACKAGING MATERIAL AS SHOWN IN FIG. A
3. ALIGN THE HOLE IN THE TOP RAIL WITH THOSE IN THE TOP OF THE UNIT AS SHOWN IN FIG. B
4. SECURE THE TOP RAIL TO THE UNIT WITH THE 3/8" SCREWS AS SHOWN IN FIG. C

**NOTE:** FOR SAFETY REASONS, ALL 4 SCREWS MUST BE USED TO ATTACH THE TOP RAIL.

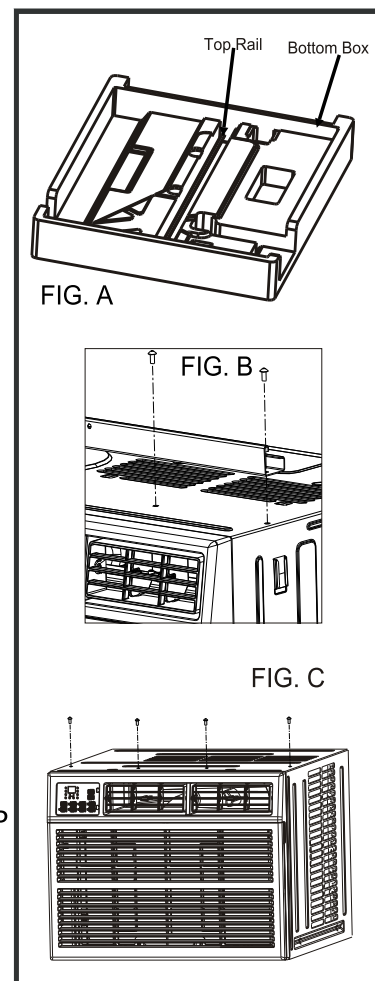

## CAUTION

When handling the unit, be careful to avoid cuts from the sharp metal edges and aluminum fins on the front and rear coils.

## INSTALLATION & ASSEMBLY INSTRUCTIONS

### HOW TO INSTALL

**NOTE:** TOP RAIL AND SLIDING PANELS AT EACH SIDE ARE OFFSET TO PROVIDE THE PROPER PITCH TO THE REAR OF (5/16"). THIS IS NECESSARY FOR PROPER CONDENSED WATER UTILIZATION AND DRAINAGE. IF YOU ARE NOT USING THE SIDE PANELS FOR ANY REASON, THIS PITCH TO THE REAR MUST BE MAINTAINED!

**TOOLS NEEDED:** PHILLIPS SCREW DRIVER & DRILL (IF PILOT HOLES ARE NEEDED)

### CAUTION

When handling unit, be careful to avoid cuts from sharp metal edges and aluminum fins on front and rear coils.

### MOUNTING HARDWARE



3/4" Screws

Qty

4



1/2" Screws

3

Lock Frame

2



Sash Lock

1

**1.** PLACE UNIT ON FLOOR, A BENCH OR A TABLE, THERE IS A LEFT AND RIGHT WINDOW FILLER PANEL – BE SURE TO USE THE PROPER PANEL FOR EACH SIDE. WHEN INSTALLED THE FLANGE FOR SECURING THE PANEL IN PLACE TO THE WINDOW SILL WILL BE FACING INTO THE ROOM.

**2.** HOLD THE ACCORDION PANEL IN ONE HAND AND GENTLY PULL BACK THE CENTER TO GREE THE OPEN END. (FIG. 3).

**3.** SLIDE THE FREE END OF THE PANEL INTO THE CABINET AS SHOWN IN (FIG. 4). SLIDE THE PANEL DOWN. BE SURE TO LEAVE ENOUGH SPACE TO SLIP THE TOP AND BOTTOM OF THE FRAME INTO THE RAILS ON THE CABINET.

**4.** ONCE THE PANEL HAS BEEN INSTALLED ON THE SIDE OF THE CABINET, MAKE SURE IT SITS SECURELY INSIDE THE FRAME CHANNEL BY MAKING SLIGHT ADJUSTMENTS. SLIDE THE TOP AND BOTTOM ENDS OF THE GRAME INTO THE TOP AND BOTTOM RAILS OF THE CABINET(FIG. 5).

**5.** SLIDE THE PANEL ALL THE WAY IN AND REPEAT ON THE OTHER SIDE.

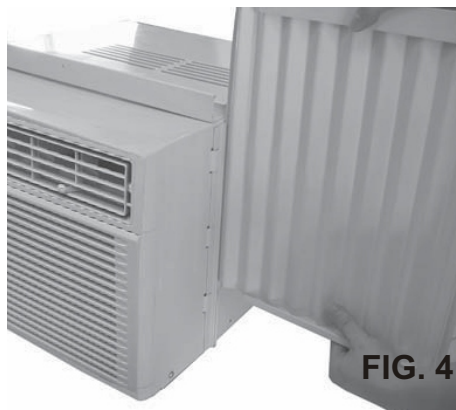
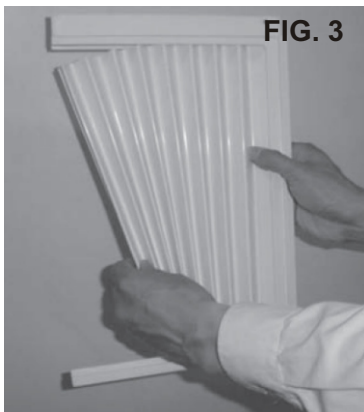

## INSTALLATION & ASSEMBLY INSTRUCTIONS

6. KEEP A FIRM GRIP ON THE AIR CONDITIONER, CAREFULLY PLACE THE UNIT INTO THE WINDOW OPENING SO THE BOTTOM OF THE AIR CONDITIONER FRAME IS AGAINST THE WINDOW SILL(FIG. 6). CAREFULLY CLOSE THE WINDOW BEHIND THE TOP RAIL OF THE UNIT. (SUGGEST TO KEEP A DOWNWARD OBLIQUE, TO LET ACCUMULATED RAIN WATER DRAIN OUT, FROM BACK OF THE UNIT BOTTOM.)
7. EXTEND THE SIDE PANELS OUT AGAINST THE WINDOW FRAME(FIG. 7).
8. PLACE THE FRAME LOCK BETWEEN THE FRAME EXTENSIONS AND THE WINDOW SILL AS SHOWN(FIG. 8). DRIVE  $\frac{3}{4}$ "(19MM) LOCKING SCREWS THROUGH THE FRAME LOCK AND INTO THE SILL (FIG. 9). **NOTE:** TO PREVENT WINDOW SILL FROM SPLITTING, DRILL  $\frac{1}{8}$ " (3MM) PILOT HOLES BEFORE DRIVING SCREWS.
9. DRIVE  $\frac{1}{2}$ " (12.7MM) LOCKING SCREWS THROUGH FRAME HOLES INTO WINDOW SASH(FIG. 10/11).



10. TO SECURE LOWER SASH IN PLACE, ATTACH RIGHTANGLE SASH LOCK WITH  $\frac{3}{4}$ " (19MM) SCREW AS SHOWN (FIG. 12).
11. CUT FOAM SEAL AND INSERT IN THE SPACE BETWEEN THE UPPER AND LOWER SASHES AS SHOWN (FIG. 13).

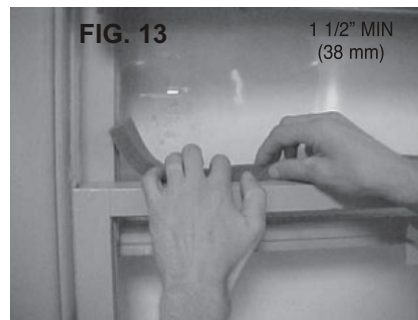

## **INSTALLATION & ASSEMBLY INSTRUCTIONS**

### **IF AC IS BLOCKED BY STORM WINDOW**

ADD WOOD AS SHOWN IN (FIG. 14). OR REMOVE STORM WINDOW BEFORE AIR CONDITIONER IS INSTALLED.

IF STORM WINDOW FRAME MUST REMAIN, BE SURE THE DRAIN HOLES OR SLOTS ARE NOT CAULKED OR PAINTED SHUT. ACCUMULATED RAIN WATER OR CONDENSATION MUST BE ALLOWED TO DRAIN OUT.

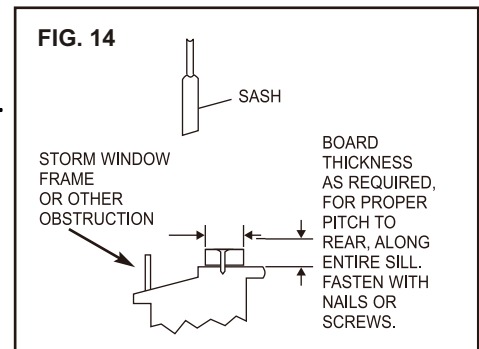

### **AIR CONDITIONER USE**

OPERATING YOUR AIR CONDITIONER PROPERLY HELPS YOU TO OBTAIN THE BEST POSSIBLE RESULTS.

THIS SECTION EXPLAINS PROPER AIR CONDITIONER OPERATION.

#### **IMPORTANT:**

\*IF YOU TURN OFF THE AIR CONDITIONER, WAIT AT LEAST 3 MINUTES BEFORE TURNING IT BACK ON. THIS PREVENTS THE AIR CONDITIONER FROM BLOWING A FUSE OR TRIPPING A CIRCUIT BREAKER.

\*DO NOT TRY TO OPERATE YOUR AIR CONDITIONER IN THE COOLING MODE WHEN OUTSIDE TEMPERATURE IS BELOW 65 DEGREES F (18 DEGREES C). THE INSIDE EVAPORATOR COIL WILL FREEZE UP, AND THE AIR CONDITIONER WILL NOT OPERATE PROPERLY.

**NOTE:** IN THE EVENT OF A POWER FAILURE, YOUR AIR CONDITIONER WILL OPERATE AT THE PREVIOUS SETTINGS WHEN THE POWER IS RESTORED.

### **REMOVING AC FROM THE WINDOW**

\*TURN THE AC OFF, AND DISCONNECT THE POWER CORD.

\*REMOVE SASH SEAL FROM BETWEEN WINDOWS AND UNSCREW SAFETY LOCK.

\*REMOVE SCREWS INSTALLED THROUGH FRAME AND FRAME LOCK.

\*CLOSE (SLIDE)SIDE PANELS INTO FRAME.

\*KEEPING A FIRM GRIP ON AIR CONDITIONER, RAISE SASH AND CAREFULLY "ROCK" AIR CONDITIONER BACKWARD TO DRAIN ANY CONDENSATE WATER IN BASE OF UNIT. BE CAREFUL NOT TO SPILL ANY REMAINING WATER WHILE LIFTING THE UNIT FROM THE WINDOW. STORE PARTS WITH AIR CONDITIONER.

## USING YOUR AIR CONDITIONER

### **ELECTRONIC CONTROL PANEL & REMOTE CONTROL**

**NOTE:** THIS DISPLAY ALWAYS SHOWS THE ROOM TEMPERATURE IN FAN MODE EXCEPT WHEN SETTING THE SET TEMPERATURE OR THE TIMER.

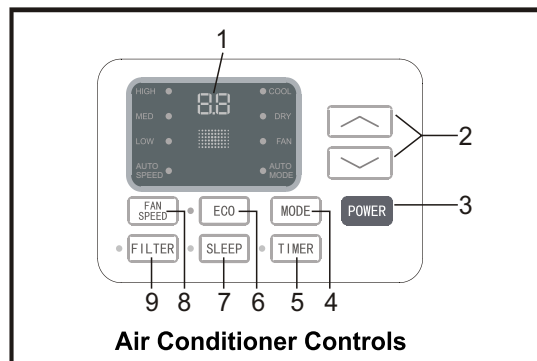

**DIGITAL DISPLAY:** WITHOUT TIMER SETTING, THE OPERATION MODE IS COOLING, DRY, FAN AND AUTO. THE SET TEMPERATURE WILL BE DISPLAYED AND THE TIME WILL BE DISPLAYED UNDER THE TIMER SETTING.

**UP AND DOWN BUTTON:** USE THESE BUTTONS ON THE CONTROL PANEL AND REMOTE TO INCREASE OR DECREASE THE SET TEMPERATURE OR TIMER. TEMPERATURE RANGE: 61 DEGREES F. – 88 DEGREES F. OR 16 DEGREES C. – 31 DEGREES C.

**POWER BUTTON:** TURN THE AIR CONDITIONER ON AND OFF.

**MODE BUTTON:** PRESS THE MODE BUTTON TO CYCLE THROUGH

THE VARIOUS MODES: COOL, DRY, FAN AND AUTO.

**COOL MODE:** THE COOLING FUNCTION ALLOWS THE AIR CONDITIONER TO COOL THE ROOM AND AT THE SAME TIME REDUCES AIR HUMIDITY. PRESS THE MODE BUTTON TO ACTIVATE THE COOLING FUNCTION. TO OPTIMIZE THE FUNCTION OF THE AIR CONDITIONER, ADJUST THE TEMPERATURE AND THE SPEED BY PRESSING THE BUTTON INDICATED.

**DRY MODE:** THIS FUNCTION REDUCES THE HUMIDITY OF THE AIR TO MAKE THE ROOM MORE COMFORTABLE. PRESS THE MODE BUTTON TO SET THE DRY MODE. AN AUTOMATIC FUNCTION OF ALTERNATING COOLING CYCLES AND AIR FAN IS ACTIVATED.

**FAN MODE:** THE AIR CONDITIONER WORKS IN ONLY VENTILATION. PRESS MODE BUTTON TO SET THE FAN MODE. WITH PRESSING FAN SPEED BUTTON THE SPEED CHANGES IN THE FOLLOWING SEQUENCE: HIGH, MEDIUM AND LOW IN FAN MODE. THE REMOTE CONTROL ALSO STORES THE SPEED THAT WAS SET IN THE PREVIOUS MODE OF OPERATION.

**AUTO MODE:** IN AUTO MODE THE UNIT AUTOMATICALLY CHOOSES THE FAN SPEED AND THE MODE OF OPERATION (COOL, DRY OR FAN). IN THIS MODE THE FAN SPEED AND THE TEMPERATURE IS SET AUTOMATICALLY ACCORDING TO THE ROOM TEMPERATURE (TESTED BY THE TEMPERATURE SENSOR WHICH IS INCORPORATED IN THE INDOOR UNIT).

**TIMER BUTTON:** USE THE TIMER BUTTON ON THE CONTROL PANEL OR THE REMOTE TO SET THE TIMER.

TIMER ON: WHEN THE UNIT IS IN STANDBY, PRESS THE TIMER BUTTON TO SET THE TEMPERATURE, THEN PRESS THE TIMER BUTTON TO SET THE TIMER TO ON, AND PRESS " ^ " AND " v " BUTTON TO ADJUST THE SETTING TIME AS YOU NEED, AFTER THE DISPLAY IS STABLE, PRESS THE TIMER BUTTON TO CONFIRM.

TIMER OFF: PRESS THE TIMER BUTTON TO TURN TIMER OFF, AND PRESS THE " ^ " AND " v " BUTTONS TO SET THE SHUT OFF TIMER, AFTER THE DISPLAY STOPS FLASHING, PRESS THE TIMER BUTTON TO CONFIRM WHAT YOU HAVE SELECTED.

**TIMER NOTE:** IT CAN BE SET TO AUTOMATICALLY TURN OFF OR ON IN 0.5-24 HOURS. EACH PRESS OF THE UP OR DOWN BUTTONS WILL INCREASE OR DECREASE THE TIMER. THE TIMER CAN BE SET IN HALF HOUR INCREMENTS BELOW 10 HOURS AND 1 HOUR INCREMENTS FOR 10 HOURS OR ABOVE. THE SET LIGHT WILL TURN ON WHILE SETTING. TO CANCEL THE SET FUNCTION, PRESS THE TIMER BUTTON AGAIN.

**NORMAL OPERATING SOUNDS:** \*YOU MAY HEAR A PINGING NOISE CAUSED BY WATER HITTING THE CONDENSER, ON RAINY DAYS, OR WHEN THE HUMIDITY IS HIGH. THIS DESIGN FEATURE HELPS REMOVE MOISTURE AND IMPROVE EFFICIENCY. \* YOU MAY HEAR THE THERMOSTAT CLICK WHEN THE COMPRESSOR CYCLES ON AND OFF. \* WATER WILL COLLECT IN THE BASE PAN DURING RAIN OR DAYS OF HIGH HUMIDITY. THE WATER MAY OVERFLOW AND DRIP FORM THE OUTSIDE PART OF THE UNIT. \*THE FAN MAY RUN EVEN WHEN THE COMPRESSOR IS NOT ON.

## USING YOUR AIR CONDITIONER

### **ELECTRONIC CONTROL PANEL & REMOTE CONTROL**

**ECO BUTTON:** WHEN THE UNIT IS IN ECO MODE, THE LIGHT WILL TURN ON. IN ECO MODE, THE UNIT WILL TURN OFF ONCE THE ROOM IS COOLED TO THE USER SET TEMPERATURE. THE FAN WILL ALSO BE OFF AT THIS POINT. THE UNIT WILL TURN BACK ON WHEN THE ROOM TEMPERATURE RISES ABOVE THE USER SET TEMPERATURE. BEFORE THE COMPRESSOR STARTS, THE FAN MOTOR WILL RUN FOR A WHILE, THEN IT WILL STOP FOR A WHILE AND WILL REPEAT TO PROVIDE A MUCH MORE COMFORTABLE FEELING AND SAVE ENERGY.

**SLEEP BUTTON:** PRESS THE SLEEP BUTTON, ALL OF THE DISPLAY LIGHTS WILL TURN OFF AFTER A WHILE, BUT THE SLEEP LIGHT IS ALWAYS ON. IN SLEEP MODE, THE AIR CONDITIONER WILL AUTOMATICALLY ADJUST THE TEMPERATURE AND FAN SPEED TO MAKE THE ROOM MORE COMFORTABLE DURING THE NIGHT. THE SET TEMPERATURE WILL AUTOMATICALLY RAISE EVERY 30-60 MINUTES, AND AT MOST CHANGE SIX TIMES UNTIL THE SET TEMPERATURE IS 81 OR 82°F.

**FAN SPEED BUTTON:** PRESS THE FAN SPEED BUTTON TO CHOOSE THE FAN SPEED OPTIONS. YOU CAN CHOOSE HIGH, MEDIUM, LOW OR AUTO SPEED IN COOL MODE AND CHOOSE HIGH, MEDIUM OR LOW IN FAN MODE.

**FILTER BUTTON:** WHEN THE FILTER CHECK LIGHT IS OFF, IT IS USELESS TO PRESS THE FILTER CHECK BUTTON. WHEN THE FILTER CHECK LIGHT IS ON, IT CAN BE TURNED OFF BY PRESSING THE FILTER CHECK BUTTON. AFTER THE FAN MOTOR WORKS FOR A TOTAL OF 500 HOURS, THE FILTER CHECK LIGHT WILL TURN ON TO REMIND THE USER TO CLEAN THE FILTER.

**DIRECTIONAL LOUVERS:** TO DIRECT THE AIRFLOW, USE THE HORIZONTAL WHEEL TO CONTROL THE HORIZONTAL DIRECTION. USE THE AIR DEFLECTOR ON EITHER SIDE TO CONTROL THE VERTICAL DIRECTION.

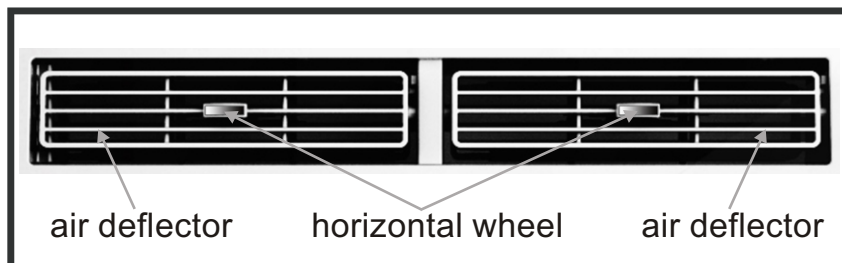

## USING YOUR AIR CONDITIONER

### REMOTE CONTROL

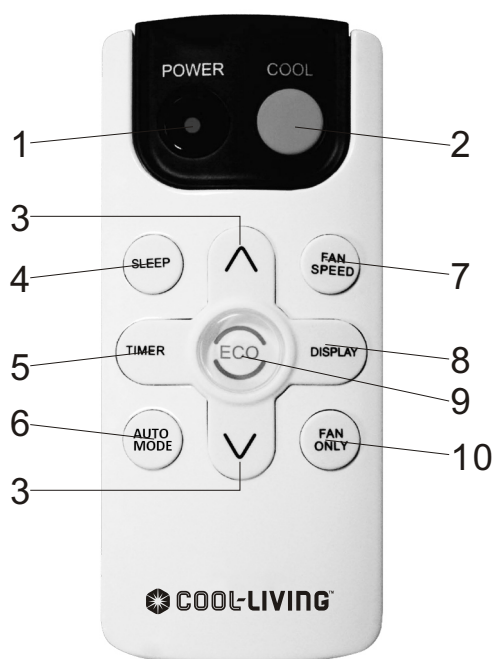

**POWER:** TURN THE AIR CONDITIONER ON AND OFF.

**COOL:** PRESS THE COOL BUTTON TO SWITCH TO COOL MODE

**UP AND DOWN:** USE THESE BUTTONS ON THE CONTROL PANEL OR REMOTE TO INCREASE OR DECREASE THE SET TEMPERATURE OR TIMER. TEMPERATURE RANGE: 61 DEGREE'S F. – 88 DEGREE'S F. OR 16 DEGREE'S C. – 31 DEGREE'S C.

**SLEEP:** PRESS THE SLEEP BUTTON, ALL OF THE DISPLAY LIGHTS WILL TURN OFF AFTER A WHILE, BUT THE SLEEP LIGHT IS ALWAYS ON. IN SLEEP MODE, THE AIR CONDITIONER WILL AUTOMATICALLY ADJUST THE TEMPERATURE AND FAN SPEED TO MAKE THE ROOM MORE COMFORTABLE DURING THE NIGHT. THE SET TEMPERATURE WILL AUTOMATICALLY RAISE EVERY 30-60 MINUTES, AND AT MOST CHANGE SIXTIMES UNTIL THE SET TEMPERATURE IS 81 OR 82°F.

**TIMER:** USE THESE BUTTONS ON THE CONTROL PANEL OR REMOTE TO SET THE TIMER.

**TIMER OFF:** WHEN THE UNIT IS RUNNING, PRESS THE TIMER BUTTON TO SET THE TIMER TO OFF, THEN PRESS THE "∧" AND "∨" BUTTON

TO AJUST THE SETTING TIME AS YOU NEED, AFTER THE DISPLAY IS STABLE, PRESS THE TIMER BUTTON TO CONFIRM.

**TIMER ON:** WHEN THE UNIT IS IN STANDBY, PRESS THE TIMER BUTTON TO SET THE TEMPERATURE, THEN PRESS THE TIMER BUTTON TO SET THE TIMER TO ON, AND PRESS "∧" AND "∨" BUTTON TO ADJUST THE SETTING TIME AS YOU NEED, AFTER THE DISPLAY IS STABLE, PRESS THE TIMER BUTTON TO CONFIRM.

**TIMER NOTE:** IT CAN BE SET TO AUTOMATICALLY TURN OFF OR ON IN 0.5-24 HOURS. EACH PRESS OF THE UP OR DOWN BUTTONS WILL INCREASE OR DECREASE THE TIMER. THE TIMER CAN BE SET IN HALF HOUR INCREMENTS BELOW 10 HOURS AND 1 HOUR INCREMENTS FOR 10 HOURS OR ABOVE. THE SET LIGHT WILL TURN ON WHILE SETTING. TO CANCEL THE SET FUNCTION, PRESS THE TIMER BUTTON AGAIN.

**AUTO MODE:** IN AUTO MODE THE UNIT AUTOMATICALLY CHOOSES THE FAN SPEED AND THE MODE OF OPERATION (COOL, DRY OR FAN). IN THIS MODE THE FAN SPEED AND THE TEMPERATURE IS SET AUTOMATICALLY ACCORDING TO THE ROOM TEMPERATURE (TESTED BY THE TEMPERATURE SENSOR WHICH IS INCORPORATED IN THE INDOOR UNIT).

**FAN SPEED:** PRESS THE FAN SPEED BUTTON TO CHOOSE THE FAN SPEED OPTIONS. YOU CAN CHOOSE HIGH, MEDIUM, LOW OR AUTO SPEED IN COOL MODE OR CHOOSE HIGH, MEDIUM OR LOW IN FAN MODE.

**DISPLAY:** PRESS THE DISPLAY BUTTON TO SWITCH OFF OR ON ALL THE LIGHTS OR LED DISPLAY ON THE UNIT.

**ECO:** WHEN THE UNIT IS IN ECO MODE, THE LIGHT WILL TURN ON. IN ECO MODE, THE UNIT WILL TURN OFF ONCE THE ROOM IS COOLED TO THE USER SET TEMPERATURE. THE FAN WILL ALSO BE OFF AT THIS POINT. THE UNIT WILL TURN BACK ON WHEN THE ROOM TEMPERATURE RISES ABOVE THE USER SET TEMPERATURE. BEFORE THE COMPRESSOR STARTS, THE FAN MOTOR WILL RUN FOR A WHILE, THEN IT WILL STOP FOR A WHILE AND WILL REPEAT TO PROVIDE A MUCH MORE COMFORTABLE FEELING AND SAVE ENERGY.

**FAN ONLY:** PRESS THE FAN ONLY BUTTON TO RUN THE FAN ONLY.

**BATTERY:** THE BATTERY SIZE FOR THE REMOTE IS AAA.

**NOTE:** DO NOT MIX OLD AND NEW BATTERIES OR DIFFERENT TYPES OF AAA BATTERIES.

## **CARE AND CLEANING**

**CLEAN YOUR AIR CONDITIONER TO KEEP IT LOOKING NEW AND TO MINIMIZE DUST BUILD UP.**

### **AIR FILTER CLEANING**

THE AIR FILTER SHOULD BE CHECKED AT LEAST ONCE EVERY MONTH TO SEE IF IT NEEDS CLEANING. TRAPPED PARTICLES AND DUST CAN BUILD UP IN THE FILTER AND MAY DECREASE AIRFLOW AS WELL AS CAUSE THE COOLING COILS TO ACCUMULATE FROST. TO CLEAN THE AIR FILTER:

1. REMOVE THE FILTER BY PULLING DOWN ON THE INDENTS OF THE FILTER DOOR ON THE FRONT OF THE UNIT. (FIG. 15).
2. WASH THE FILTER USING LIQUID DISH SOAP AND WARM WATER. RINSE FILTER THOROUGHLY, GENTLY SHAKE THE FILTER TO REMOVE EXCESS WATER.
3. LET THE FILTER DRY COMPLETELY BEFORE PLACING IT INTO THE AIR CONDITIONER.
4. IF YOU DO NOT WISH TO WASH THE FILTER, YOU MAY VACUUM THE FILTER TO REMOVE THE DUST AND OTHER PARTICLES.

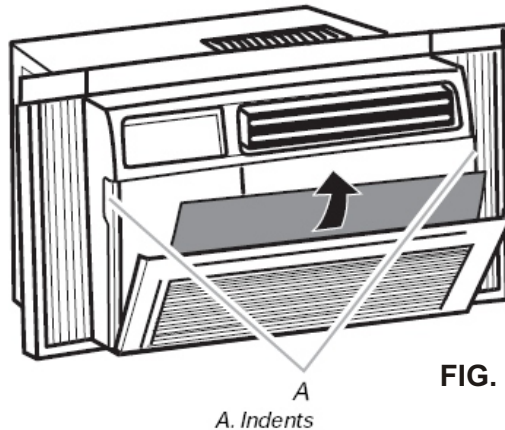

**FIG. 15**

### **CABINET CLEANING**

**TO CLEAN THE AIR CONDITIONER CABINET:**

\*UNPLUG THE AIR CONDITIONER TO PREVENT SHOCK OR A FIRE HAZARD. THE CABINET AND FRONT PANEL OF THE AIR CONDITIONER MAY BE DUSTED WITH AN OIL FREE CLOTH OR WASHED WITH A CLOTH DAMPENED IN A SOLUTION OF WARM WATER AND MILD LIQUID SOAP. RINSE THOROUGHLY WITH A DAMP CLOTH AND WIPE DRY.

\*NEVER USE HARSH CLEANERS, WAX OR POLISH ON THE CABINET FRONT.

\*BE SURE TO WRING EXCESS WATER FROM THE CLOTH BEFORE WIPING AROUND THE CONTROLS. EXCESS WATER IN OR AROUND THE CONTROLS MAY CAUSE DAMAGE TO THE AIR CONDITIONER.

### **WINTER STORAGE**

TO STORE THE AIR CONDITIONER WHEN IT IS NOT IN USE FOR AN EXTENDED PERIOD OF TIME, REMOVE IT CAREFULLY FROM THE WINDOW ACCORDING TO THE INSTALLATION INSTRUCTIONS AND COVER IT WITH PLASTIC OR PLACE IT IN THE ORIGINAL BOX.

### **WEAR AND TEAR**

TO MINIMIZE WEAR AND TEAR ON THE AIR CONDITIONER, ALWAYS WAIT AT LEAST 3 MINUTES BEFORE CHANGING MODES. THIS WILL HELP PREVENT THE COMPRESSOR FROM OVERHEATING AND THE CIRCUIT BREAKER FROM TRIPPING.



## TROUBLESHOOTING

<b>PROBLEM</b>	<b>POSSIBLE CAUSES</b>	<b>SOLUTIONS</b>
<b>The Air Conditioner will not start</b>	The air conditioner is unplugged	<ul style="list-style-type: none"> <li>• Make sure the air conditioner plug is pushed completely into the outlet</li> </ul>
	The fuse is blown/circuit breaker is tripped.	<ul style="list-style-type: none"> <li>• Check the house fuse/circuit breaker box and replace the fuse or reset the breaker.</li> </ul>
	Power failure	<ul style="list-style-type: none"> <li>• The unit will automatically re-start when power is restored.</li> <li>• There is a protective time delay (approx. 3 minutes) to prevent tripping of the compressor overload. For this reason, the unit may not start normal cooling for 3 minutes after it is turned back on.</li> </ul>
	The current interrupter device is tripped.	<ul style="list-style-type: none"> <li>• Press the RESET button located on the power cord plug.</li> <li>• If the RESET button will not stay engaged, discontinue use of the air conditioner and contact a qualified service technician.</li> </ul>
<b>The Air Conditioner does not cool as it should</b>	Airflow is restricted	<ul style="list-style-type: none"> <li>• Make sure there are no curtains, blinds, or furniture blocking the front of the air conditioner</li> </ul>
	The temperature control may not be set correctly.	<ul style="list-style-type: none"> <li>• Lower the set thermostat temperature</li> </ul>
	The air filter is dirty	<ul style="list-style-type: none"> <li>• Clean the filter. See the Cleaning and Care Section of the manual.</li> </ul>
	The room may be too warm	<ul style="list-style-type: none"> <li>• Please allow time for the room to cool down after turning on the air conditioner.</li> </ul>
	Cold air is escaping	<ul style="list-style-type: none"> <li>• Check for open furnace registers and cold air returns</li> </ul>
	The cooling coils are frozen	<ul style="list-style-type: none"> <li>• See "Air Conditioner Freezing Up" below.</li> </ul>
<b>The Air Conditioner is freezing up</b>	Ice blocks the air flow and stops the air conditioner from cooling the room	<ul style="list-style-type: none"> <li>• Set the MODE dial to HIGH FAN or HIGH COOL and set the thermostat to a higher temperature</li> </ul>
<b>The Remote Control is not working</b>	The batteries are inserted incorrectly The batteries may be dead	<ul style="list-style-type: none"> <li>• Check the position of the batteries.</li> <li>• Replace the batteries</li> </ul>
<b>Water is dripping outside</b>	Hot and humid weather.	<ul style="list-style-type: none"> <li>• This is normal</li> </ul>
<b>Water is dripping inside the room</b>	The air conditioner is not correctly tilted outside.	<ul style="list-style-type: none"> <li>• For proper water drainage, make sure the air conditioner is slightly tilted downward from the front of the unit to the rear.</li> </ul>
<b>Water collects in the base pan</b>	Moisture removed from the air is draining into the base pan.	<ul style="list-style-type: none"> <li>• This is normal for a short period in areas with low humidity and normal for a longer period in areas with high humidity.</li> </ul>

## **WARRANTY**

### **6 MONTHS LIMITED WARRANTY**

**IN ORDER TO UTILIZE THE WARRANTY YOU MUST REGISTER YOUR PURCHASE WITH IN 30 DAYS FROM THE DATE OF PURCHASE.**

THE MANUFACTURER WARRANTS THIS UNIT AGAINST DEFECTS IN MATERIALS AND WORKMANSHIP ON FUNCTIONAL PARTS, FOR A PERIOD OF 6 MONTHS FROM THE ORIGINAL DATE OF PURCHASE. YOUR SALES RECEIPT SHOWING THE DATE OF PURCHASE OF THE PRODUCT IS YOUR PROOF OF PURCHASE. KEEP IT IN A SAFE PLACE FOR FUTURE REFERENCE.

THIS PRODUCT IS MADE WITH THE HIGHEST QUALITY MATERIALS AND IS WARRANTED TO BE FREE FROM DEFECTS IN MATERIALS AND WORKMANSHIP AT THE TIME OF PURCHASE. THIS LIMITED WARRANTY APPLIES TO PRODUCTS MANUFACTURED OR DISTRIBUTED BY THE MANUFACTURER, ARE DELIVERED IN THE CONTINENTAL UNITED STATES, AND EXTENDS TO THE ORIGINAL PURCHASER, OR GIFT RECIPIENT. THIS WARRANTY BECOMES VALID AT THE TIME OF PURCHASE AND TERMINATES EITHER BY THE SPECIFIED TIME FRAME LISTED ABOVE AND OR OWNER TRANSFER. ANY REFUNDS OR MONETARY COMPENSATIONS MUST BE CLAIMED THROUGH THE PLACE OF PURCHASE (RETAILER), AND NOT THROUGH THE MANUFACTURER. ANY EXTENDED WARRANTIES (WARRANTIES THAT COVER ABOVE AND BEYOND THIS MANUFACTURER WARRANTY) THAT ARE SOLD THROUGH A RETAILER OR THIRD PARTY, ARE NOT DIRECTLY CORRELATED WITH THIS PRODUCTS\* LIMITED WARRANTY, AND MAY BE REDIRECTED TO SAID RETAILER OR THIRD PARTY FOR COVERAGE.

THIS WARRANTY EXTENDS THROUGH THE MANUFACTURER OF THE PRODUCT, AND COVERS FUNCTIONAL PARTS ONLY. COSMETICS ARE NOT COVERED, UNLESS UNEQUIVOCALLY DETERMINED IT IS A WORKMANSHIP DEFECT. SHIPPING DAMAGE SHOULD BE ADDRESSED WITH THE SHIPPING COMPANY, RETAILER, OR PLACE OF PURCHASE, NOT THE MANUFACTURER UNLESS THE MANUFACTURER WAS THE DIRECT SHIPPER.

THE MANUFACTURER\* SOLE OBLIGATION UNDER THIS WARRANTY SHALL BE LIMITED TO FURNISHING THE ORIGINAL PURCHASER REPLACEMENT PARTS FOR UNITS DEEMED REPAIRABLE BY THE SUPPLIER\* WARRANTY DEPARTMENT. THE PURCHASER IS RESPONSIBLE FOR INSURING ANY PARTS SHIPPED OR RETURNED, IF DESIRED. THE PURCHASER IS RESPONSIBLE TO PREPAY ANY SHIPPING CHARGES (BOTH WAYS) INCLUDING, BUT NOT LIMITED TO TAXES AND DUTIES. ALL EXCHANGED PARTS AND PRODUCTS REPLACED UNDER THIS WARRANTY WILL BECOME THE PROPERTY OF MANUFACTURER. THE MANUFACTURER RESERVES THE RIGHT TO CHANGE MANUFACTURERS OF REPLACEMENT PARTS OR PRODUCTS FOR USE, IN ORDER TO COVER ANY EXISTING WARRANTY. THE PURCHASER MAY BE ASKED TO PROVIDE THE SUPPLIER WITH PROOF OF PURCHASE DOCUMENTS INCLUDING THE DATE OF PURCHASE. ANY EVIDENCE OF ALTERATION, ERASING OR FORGERY OF PROOF OF PURCHASE DOCUMENTS WILL BE JUST CAUSE TO VOID THIS LIMITED WARRANTY. PRODUCTS, IN WHICH THE SERIAL NUMBER HAS BEEN DEFACED OR REMOVED, ARE NOT ELIGIBLE FOR WARRANTY COVERAGE.

THIS WARRANTY DOES NOT APPLY IF THE UNIT HAS BEEN SUBJECT TO NEGLIGENCE, FABRICATION, MISUSE, ABUSE OR REPAIRS; ALTERATION BY NON-MANUFACTURER AUTHORIZED PERSONNEL, INAPPROPRIATE INSTALLATIONS OR ANY CASE BEYOND THE CONTROL OF THE MANUFACTURER. EXAMPLES OF WARRANTY INVALIDATION MAY ALSO INCLUDE, BUT ARE NOT LIMITED TO:

- \*USE OF LACQUER OR PAINTS IN (AND AROUND) THE UNIT
- \*ELECTRICAL REQUIREMENT DEFICIENCIES (15-20 AMP DEDICATED OUTLET)
- \*USE ON EXTENSION CORDS/TIMERS/SURGE PROTECTORS/GFCI
- \*OUTDOOR APPLICATIONS
- \*NORMAL WEAR / TEAR / WEATHERING
- \*PET / CONSUMER ACCIDENTS

THE MANUFACTURER SHALL NOT BE LIABLE FOR ANY LOSS DUE TO USE (OR MISUSE) OF THE UNIT OR OTHER INCIDENTAL OR CONSEQUENTIAL COSTS, EXPENSES OR DAMAGES WITH OUT IRREFUTABLE FOUNDATIONS. UNDER NO CIRCUMSTANCES SHALL THE MANUFACTURER OR ANY OF ITS REPRESENTATIVES BE HELD LIABLE FOR INJURY TO ANY PERSON OR DAMAGE TO ANY PROPERTY, HOWEVER ARISING. ANY IMPLIED WARRANTY SHALL HAVE DURATION EQUAL OF THE APPLICABLE WARRANTY STATED ABOVE. SPECIFICATIONS ARE SUBJECT TO CHANGE WITHOUT NOTICE OR OBLIGATION. THIS LIMITED WARRANTY GIVES THE ORIGINAL PURCHASER SPECIFIC LEGAL RIGHTS. OTHER RIGHTS MAY VARY FROM STATE TO STATE.

**IN ORDER TO UTILIZE THE WARRANTY YOU MUST REGISTER YOUR PURCHASE WITH IN 30 DAYS FROM THE DATE OF PURCHASE.**

**REGISTRATION CARD**

**PRODUCT REGISTRATION CARD MUST BE COMPLETED ONLINE AT WWW.COOLLIVINGPRODUCTS.COM OR COMPLETE AND MAIL THE ATTACHED REGISTRATION CARD TO KMS INC. ATTN: CUSTOMER SERVICE, 811 E WATERMAN, WICHITA, KS 67202**

DATE OF PURCHASE: \_\_\_\_\_ PURCHASED FROM: \_\_\_\_\_

BRAND: \_\_\_\_\_ MODEL #: \_\_\_\_\_

**IF YOU DO NOT REGISTER YOUR WARRANTY ONLINE AT WWW.COOLLIVINGPRODUCTS.COM PLEASE FILL OUT AND MAIL THIS BOTTOM PORTION AT THE LINE BELOW. KEEP THE REST OF THIS INFORMATION IN A SAFE PLACE FOR REFERENCE. YOU HAVE 30 DAYS FROM THE DATE OF PURCHASE TO REGISTER YOUR ITEM.**

PAGE 16 OF 16

---

**COOL LIVING PRODUCT REGISTRATION CARD**

NAME: \_\_\_\_\_

PHONE # \_\_\_\_\_ - \_\_\_\_\_ - \_\_\_\_\_ EMAIL: \_\_\_\_\_

ADDRESS: \_\_\_\_\_

CITY: \_\_\_\_\_ STATE: \_\_\_\_\_ ZIP CODE: \_\_\_\_\_ - \_\_\_\_\_

PRODUCT DESCRIPTION: \_\_\_\_\_

DATE OF PURCHASE: \_\_\_\_\_ PURCHASED FROM: \_\_\_\_\_

BRAND: \_\_\_\_\_ MODEL #: \_\_\_\_\_

SERIAL #: \_\_\_\_\_

