

ITEM/Article #: A104001400

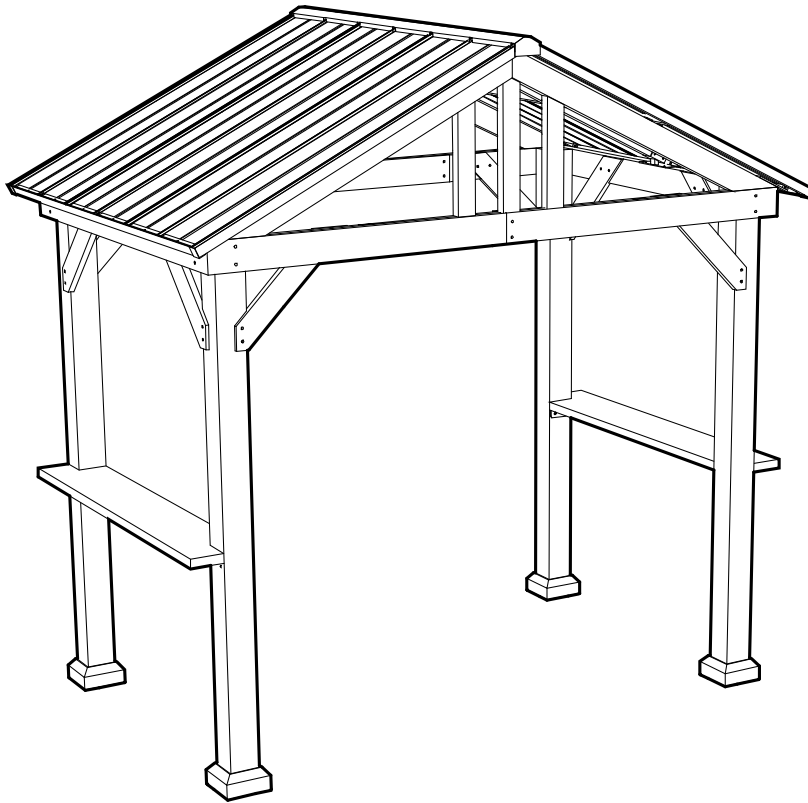

WE HAVE YOU IN MIND, LET US SERVE YOU!
Nous pensons en vous, laissez nous vous aider!

Questions? Issues? / Questions? Problèmes?

CONTACT US / Contactez-nous

24 hours / 7 days a week
24 heures / 7 jours par semaine

Warranty Parts
Liste des pièces sous
garantie

www.sunjoyonline.com

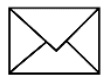

customer.care@sunjoygroup.com



Country of Origin: China
Pais d'origine: Chine

Production Number: XXXXXXXXXX
Numéro de fabrication: XXXXXXXXX

Warning:

- Check to ensure all parts are present prior to assembly.
- **This unit is heavy! At least 4 adults are needed for safe assembly ---- Never assemble this alone!**

- Keep all children and pets away from assembly area. Children and pets should be supervised when they are in the area of the gazebo construction.
- Keep assembly area more than 1.8 m / 5.9 ft from any obstruction such as a fence, garage, house, overhanging branches, laundry line or electrical wires.
- Some parts may contain sharp edges. When assembling and using this product, basic safety precautions should always be followed to reduce the risk of personal injury and damage to the product. Please read all instructions before assembly and use.
- For outdoor use only. Check all bolts for tightness before use and periodically check and tighten bolts as necessary.
- Assemble this unit on firm, level ground or hard surface only. Ensure the unit is level after final assembly.
- Protect parts during assembly by laying them on a non-abrasive surface such as blankets or cardboard.
- Wood is flammable. Grills, fire pits, fire tables and other items that produce a flame are a fire hazard if placed too close to the wood parts of this gazebo. Consult owner's manual of all flame producing items for minimum safe distances from combustible material.

General Information

Knots, small cracks and weathering are natural in an outdoor wood product and do not negatively affect the structural integrity of the gazebo. A protective water-based stain has been applied to the wood components of this product. An annual application of a water-based stain or sealant is recommended to reduce weathering and extend the life of your gazebo.

Care Instructions**On Hardware:**

Clean gently with a sponge using environmentally-friendly soap solution and water. Do not use abrasive materials, wire brushes, chemicals, cleansers or bleach. Do not use a pressure washer. Rinse well. Allow to air dry.

If there are nicks, chips or scratches, go to your local hardware store or home center and obtain a closest match touch-up paint suitable for outdoor metal use. Follow instructions that appear on the paint can.

Snow must be cleared off regularly during snowy days. Remove the snow at the top when it is thicker than 10.16 cm / 4 inches. In order to avoid damages, use a plastic snow rake to remove excessive snow and ice buildup from roof and keep away from falling debris.

On wood parts:

An annual application of a water-based stain or sealant is recommended to reduce weathering and extend the life of your gazebo.

Inspect all wood parts regularly for damage or deterioration. Remove/sand splinters and replace any wood parts that are showing signs of structural damage. Note that knots, small cracks and weathering are natural in an outdoor wood product and do not negatively affect the structural integrity of the gazebo.

AVERTISSEMENT

- Vérifier qu'il ne manque aucune pièce avant de commencer l'assemblage.
- **Ce pavillon est lourd! Au moins quatre adultes sont nécessaires à un assemblage sécuritaire. Ne jamais assembler le pavillon seul!** 
- Tenir les enfants et les animaux à l'écart ou les surveiller pendant l'assemblage.
- Assembler le pavillon à plus de 1,8 m (5,9 pi) de tout obstacle tel qu'une clôture, un garage, une maison, des branches d'arbres, une corde à linge ou des fils électriques.
- Certaines pièces ont des bords tranchants. Au moment de l'assemblage et durant l'utilisation de ce produit, toujours prendre des mesures de sécurité élémentaires pour réduire les risques de blessure ou de dommage au pavillon. Lire toutes les instructions avant d'assembler et d'utiliser le pavillon.
- Pour usage extérieur seulement. Vérifier la solidité des vis et des boulons avant la première utilisation, et de façon régulière par la suite; les resserrer au besoin.
- Assembler ce pavillon sur une surface dure ou sur un sol plan et ferme seulement. Vérifier que le produit est de niveau après l'assemblage.
- Pendant l'assemblage, protéger les pièces en les disposant sur une surface non abrasive comme une couverture ou du carton.
- Le bois est inflammable. Les grils, les foyers, les tables à foyer et tout autre article qui produit une flamme est un danger si il est placé près des pièces en bois de ce Gazébo. Consultez le manuel du propriétaire de tout article à flamme pour savoir quelle est la distance de matériels combustibles exigée.

Information Générale

Les nœuds, les fissures, et la dégradation sont naturels pour un produit extérieur en bois et n'affecte pas négativement l'intégrité de la structure du Gazébo. Une teinture à base d'eau a été appliquée aux composants de bois de cet article. Nous recommandons une application annuelle de teinture à base d'eau ou un enduit pour réduire la dégradation et allonger la vie de votre Gazébo.

ENTRETIEN

Sur la Quincaillerie :

Nettoyer doucement avec une éponge et une solution de savon écologique et d'eau. Ne pas utiliser d'abrasifs, de brosses métalliques, de produits chimiques, de nettoyeurs ou de javellisants. Ne pas utiliser de laveuse à pression. Bien rincer, et laisser sécher à l'air libre.

En cas d'éclats de peinture ou d'égratignures, se procurer une peinture pour retouches convenant à un usage sur le métal et à l'extérieur dans une quincaillerie ou un magasin à grande surface. Suivre les instructions inscrites sur le contenant.

Déneiger régulièrement le toit du pavillon lorsque l'accumulation de neige dépasse 10 cm (4 po) d'épaisseur. Pour éviter d'endommager le pavillon, enlever la neige et la glace à l'aide d'un grattoir à toiture en plastique; attention aux chutes de neige et de glace.

Sur les pièces en bois :

Nous recommandons une application annuelle de teinture à base d'eau ou un enduit pour réduire la dégradation et allonger la vie de votre Gazébo.

Vérifiez toutes les pièces en bois régulièrement pour voir si elles sont abimées ou détériorées. Ôtez et poncez les échardes et remplacez toutes pièces en bois qui dévoilent des signes de dommages structurels. Notez que les nœuds, les fissures, et la dégradation sont naturels pour un produit extérieur en bois et n'affecte pas négativement l'intégrité de la structure du Gazébo.

Ground Stakes/Expansion Bolts

For further stability, this structure can be anchored to the ground using ground stakes or expansion bolts (not included). Please check with local hardware store or contractor for suitable stakes or expansion bolts.

Two-Year Limited Warranty

This limited warranty is extended to the original purchaser and applies to defects in material and workmanship of your item provided the item is maintained with care and used only for personal, residential purposes. The manufacturer warrants this item is free of defects in material and workmanship for a period of two years. If any defect is found, please call our customer service department at 1-866-578-0101 or email at costco@sunjoygroup.com for help. The manufacturer will not cover transportation or delivery costs or compensate the individual or any outside party for assembling or disassembling the product.

Tools Needed

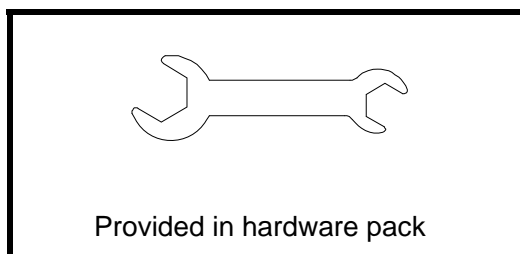
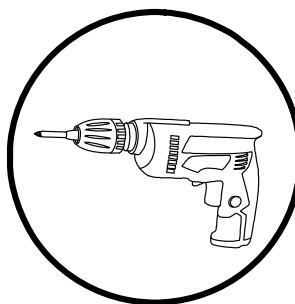
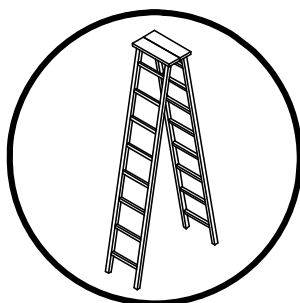
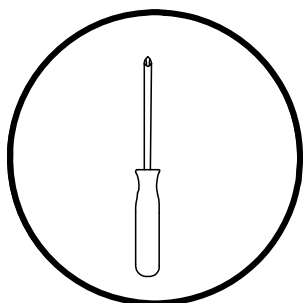

Piquets/Boulons à expansion

Pour plus de stabilité, cette structure peut s'ancrer à la terre avec les piquets ou les boulons d'expansion (pas compris). Veuillez, s'il vous plait consulter le magasin de bricolage ou le maître d'œuvre pour un conseil sur les piquets ou boulons à expansion convenables.

GARANTIE LIMITÉE DE DEUX ANS

Cette garantie limitée ne s'applique qu'à l'acheteur original et aux défauts en matériel et en main d'oeuvre de votre produit, à condition que l'article a été maintenu avec soin et utilisé uniquement pour emploi personnel et résidentiel. Le fabricant garanti que cet article n'a aucun défaut matériel et de main d'oeuvre pendant une période de deux ans. Si vous trouvez un défaut, veuillez appeler le département de service au client au numéro 1-866-578-0101 ou par email à costco@sunjoygroup.com pour de l'aide. Le fabricant ne couvre pas pour frais de transport ni de livraison et n'indemnise ni l'individu, ni n'importe quelle autre personne pour le montage et démontage du produit.



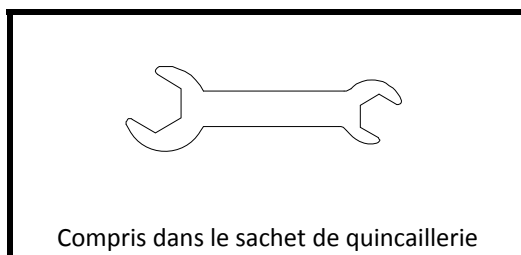
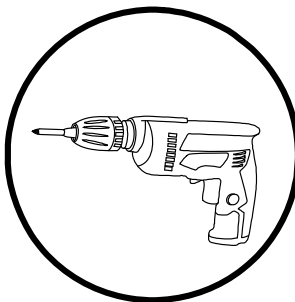
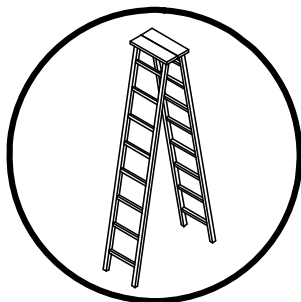
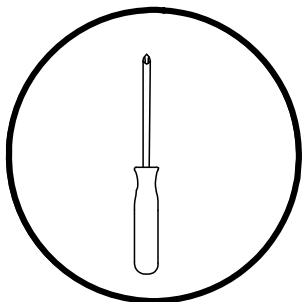



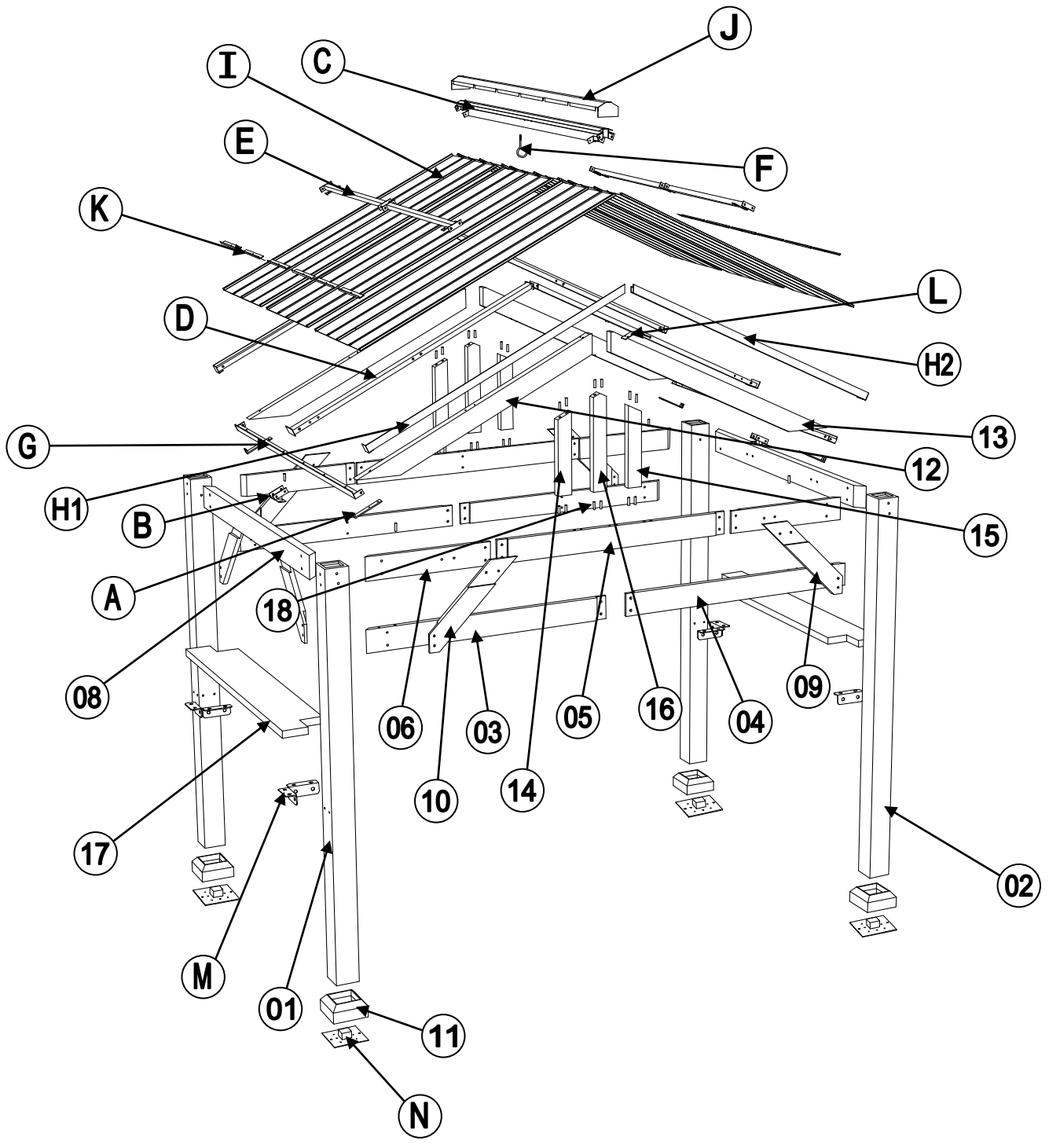







Outils requis

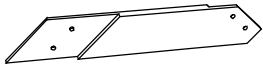
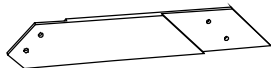















EXPLODED DRAWING



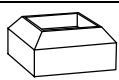





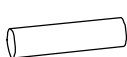

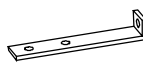
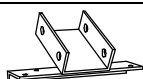

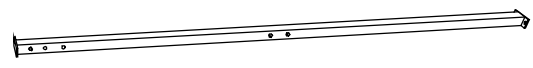

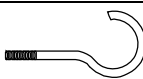

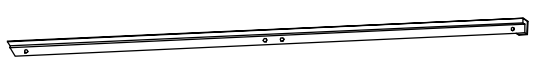
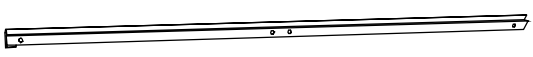



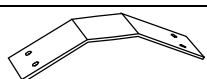

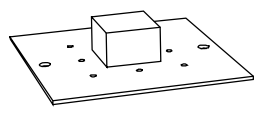

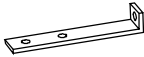
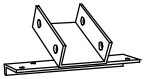

Parts List

Label	Part Number	Description	Qty	Part Image
01	P11165B10000	Post 1	2	
02	P11166B10000	Post 2	2	
03	P11002D10000	Outer left Long Beam	2	
04	P11003D10000	Outer Right Long Beam	2	
05	P11004D10000	Inner Long Beam	2	
06	P11005D10000	Inner Beam	4	
08	P11007D10000	Beam on Short Side	2	
09	P11805B10000	Right Support	4	
10	P11806B10000	Left Support	4	
11	P11546A10000	Base Cover	4	
12	P10323B10000	Left Sloping Beam	2	
13	P10324B10000	Right Sloping Beam	2	
14	P11807B10000	Left Support Beam	2	
15	P11808B10000	Right Support Beam	2	
16	P11809B10000	Middle Support Beam	2	
17	P12337A10000	Shelf	2	
18	P90407A10000	Wood Dowel	28	

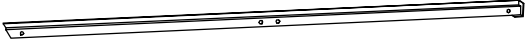
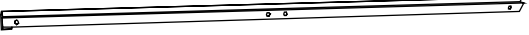

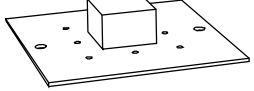

Liste de Pièces

Étiquette	No DE PIÈCE	Description	QTÉ	IMAGE
01	P11165B10000	Poteau 1	2	
02	P11166B10000	Poteau 2	2	
03	P11002D10000	Poutre longue, Extérieure gauche	2	
04	P11003D10000	Poutre longue, Extérieure droite	2	
05	P11004D10000	Poutre Longue intérieure	2	
06	P11005D10000	Poutre Intérieure gauche	4	
08	P11007D10000	Poutre du côté court	2	
09	P11805B10000	Support droit	4	
10	P11806B10000	Support gauche	4	
11	P11546A10000	Couvre-base	4	
12	P10323B10000	Poutre inclinée gauche	2	
13	P10324B10000	Poutre inclinée droite	2	
14	P11807B10000	Poutre de support gauche	2	
15	P11808B10000	Poutre de support droite	2	
16	P11809B10000	Poutre de support centrale	2	
17	P12337A10000	Etagère	2	
18	P90407A10000	Cheville en bois	28	



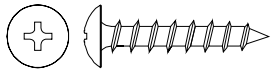

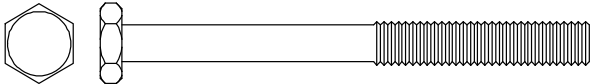
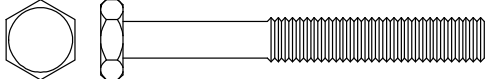
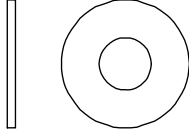
A	P11491A01147	L Shape Connector	4	
B	P10837A01147	Lower Connector	2	
C	P11008D01147	Top Beam	1	
D	P10497A01147	Middle Beam	2	
E	P13020B01147	Small Beam	4	
F	P12603A01147	Hook	1	
G	P13021B01147	Lower Small Beam	2	
H1	P13022B01147	Left Small Beam	2	
H2	P13023B01147	Right Small Beam	2	
I	P11958B01147	Roof Panel	6	
J	P12055A01147	Roof Plate	1	
K	P10639A01147	Press Panel	12	
L	P11492A01147	Washer	2	
M	P11493A01147	Shelf Connector	8	
N	P11659A01147	Base	4	

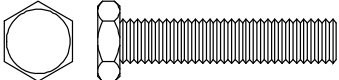
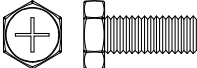
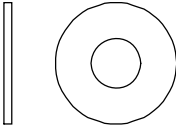
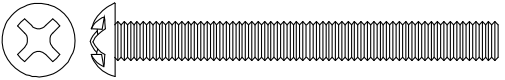
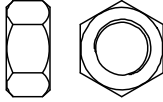
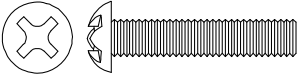
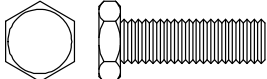
A	P11491A01147	Connexion en forme de L	4	
B	P10837A01147	Connexion inférieure	2	
C	P11008D01147	Poutre du toit	1	
D	P10497A01147	Poutre centrale	2	
E	P13020B01147	Petite poutre	4	
F	P12603A01147	Crochet	1	
G	P13021B01147	Petite poutre inférieure	2	
H1	P13022B01147	Petite Poutre gauche	2	
H2	P13023B01147	Right Small Beam	2	
I	P11958B01147	Petite Poutre droite	6	
J	P12055A01147	Lame du toit	1	
K	P10639A01147	Lame à pression	12	
L	P11492A01147	Rondelle	2	
M	P11493A01147	Connexion de l'étagère	8	
N	P11659A01147	Base	4	

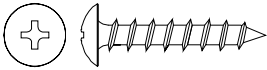

Hardware Pack

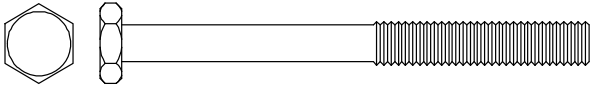
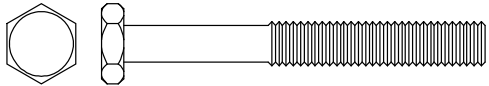
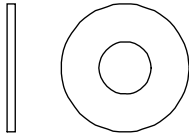
Label	Part Number	Description	Qty	Add	Part Image
AA	H10030K11	Screw M5*30	36	8	
BB	H06035D31	Bolt M8*35	16	2	
CC	H01180D31	Bolt M8*180	8	1	
DD	H01070D31	Bolt M8*70	8	1	
EE	H19001D31	Flat washer M8	88	9	
FF	H22001D31	Nut M8	8	1	
GG	H01030D31	Bolt M8*30	32	4	
HH	H02015C31	Bolt M6*15	48	5	
JJ	H19001C31	Flat washer M6	62	7	
KK	H09070C31	Bolt M6*70	4	1	
LL	H14001C31	Nut M6	4	1	
MM	H09030C31	Bolt M6*30	2	1	
NN	H01020D31	Bolt M8*20	32	4	

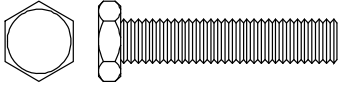
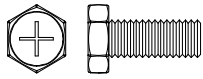
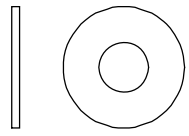
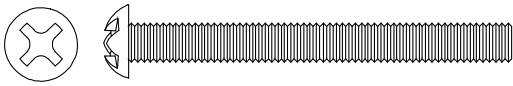
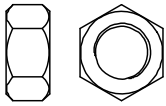
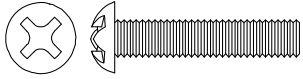
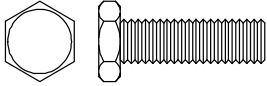
Quincaillerie pour l'étape

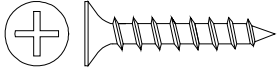
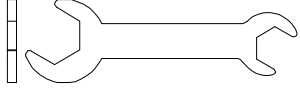
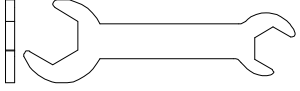
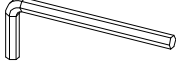
Étiquette	No DE PIÈCE	Description	QTÉ	Rechange	IMAGE
AA	H10030K11	Vis courte M5*30	36	8	
BB	H06035D31	Boulon M8*35	16	2	
CC	H01180D31	Boulon M8*180	8	1	
DD	H01070D31	Boulon M8*70	8	1	
EE	H19001D31	Rondelle Plate M8	88	9	
FF	H22001D31	Écrou M8	8	1	
GG	H01030D31	Boulon M8*30	32	4	
HH	H02015C31	Boulon M6*15	48	5	
JJ	H19001C31	Rondelle Plate M6	62	7	
KK	H09070C31	Boulon M6*70	4	1	
LL	H14001C31	Écrou M6	4	1	
MM	H09030C31	Boulon M6*30	2	1	
NN	H01020D31	Boulon M8*20	32	4	

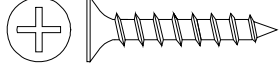
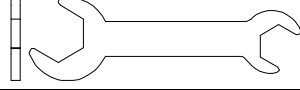
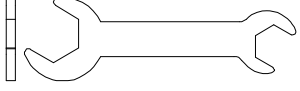
PP	H10030K11	Screw M5*30	32	4	
Z1	H00001D12	Wrench M8	2	0	
Z2	H00001M12	Wrench M8/M6	2	0	
Z3	H00002D12	Allen Key M8	1	0	

PP	H10030K11	Vis courte M5*30	32	4	
Z1	H00001D12	Clé M8	2	0	
Z2	H00001M12	Clé M8/M6	2	0	
Z3	H00002D12	Clé Hexagonale M8	1	0	

1

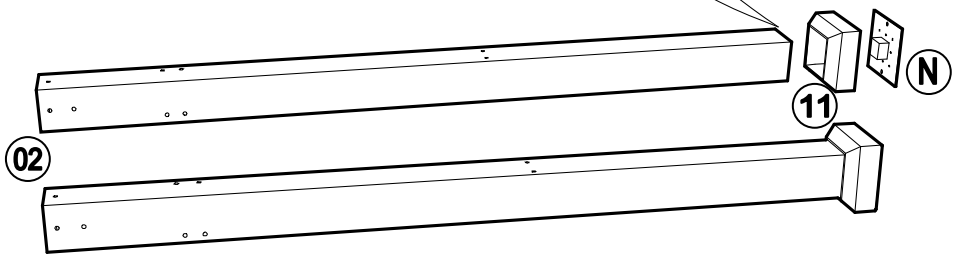
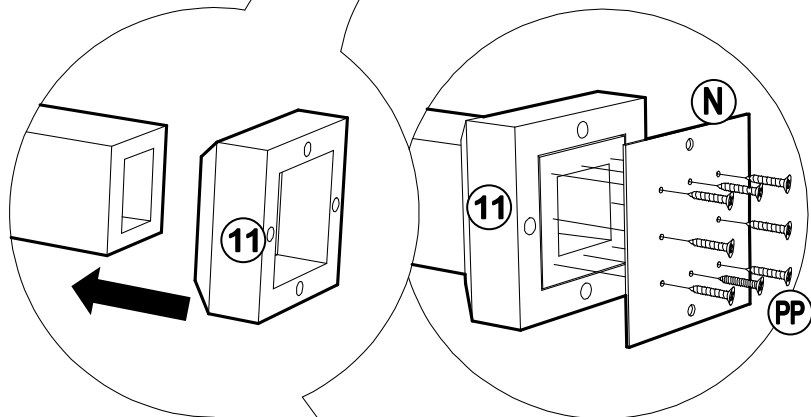
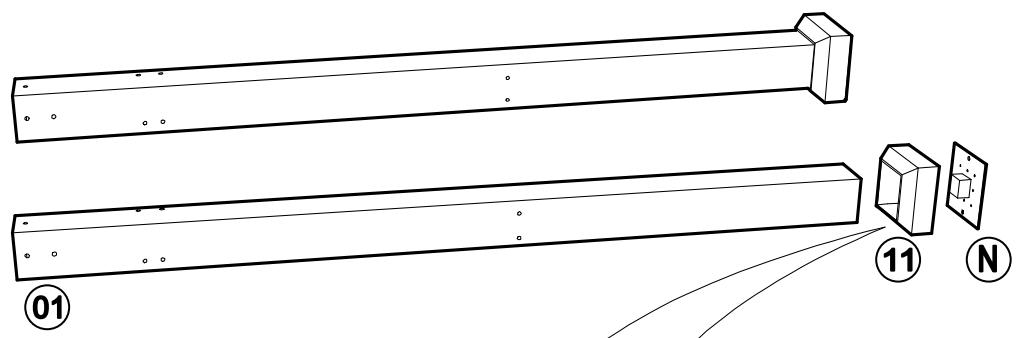
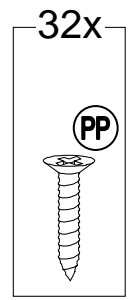
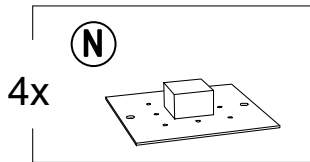
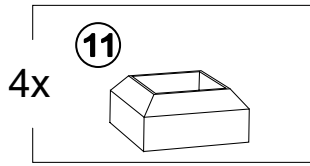
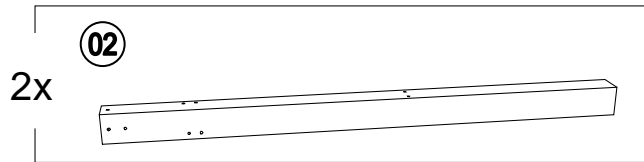
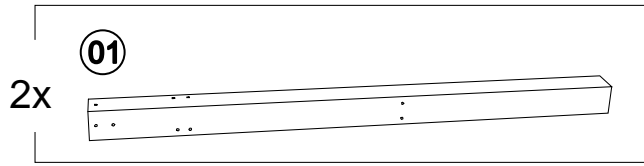

2

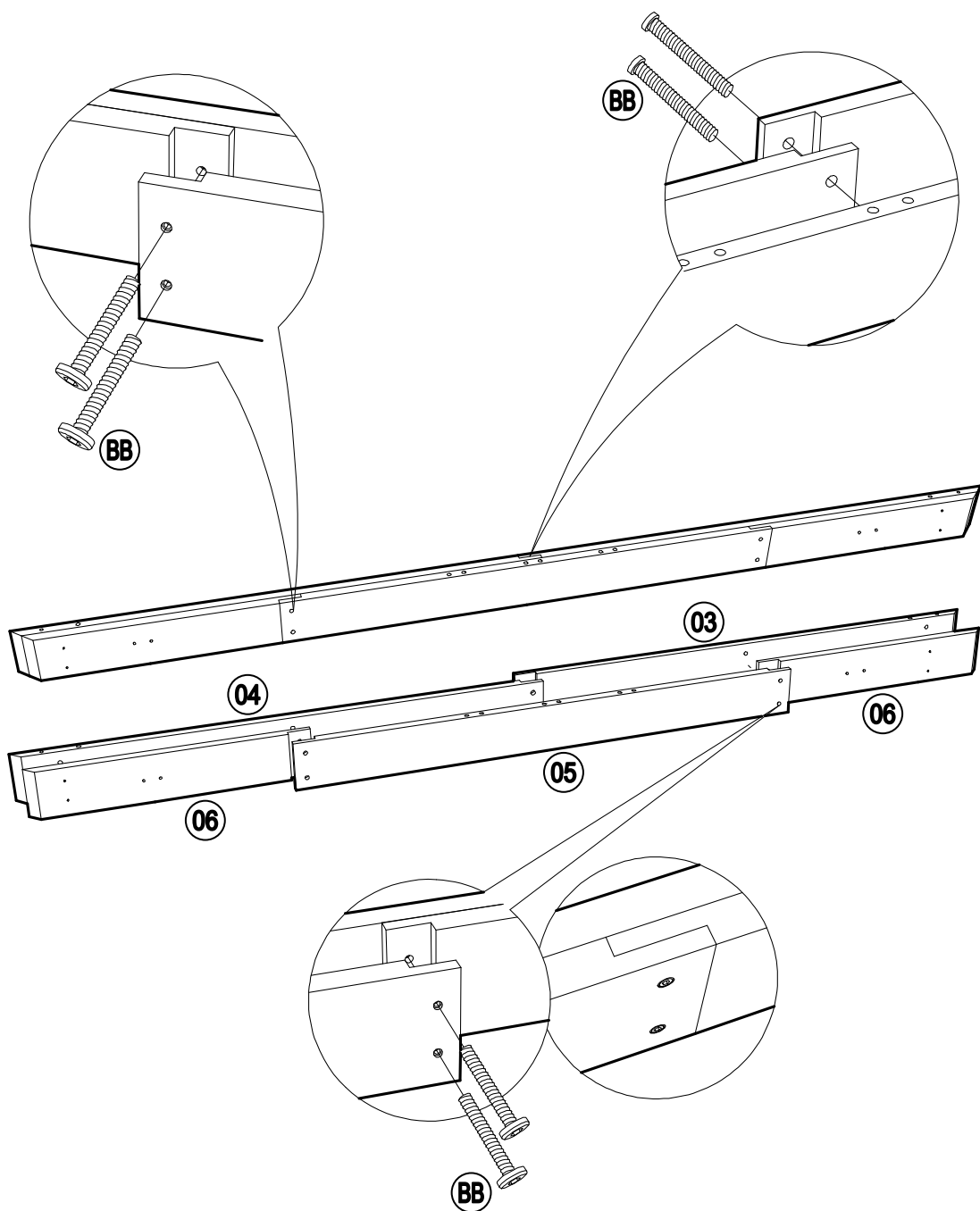
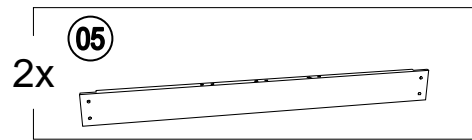
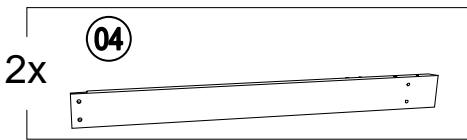
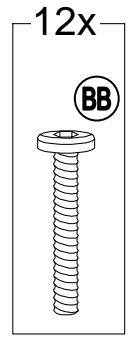
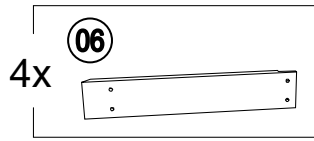
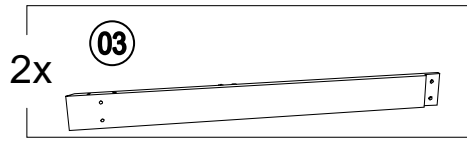

3

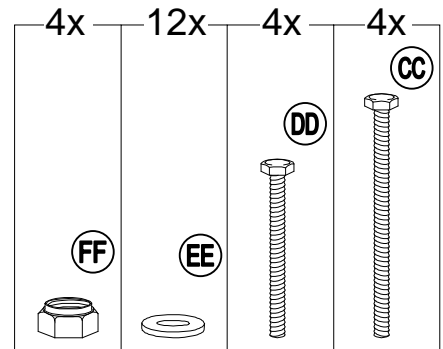
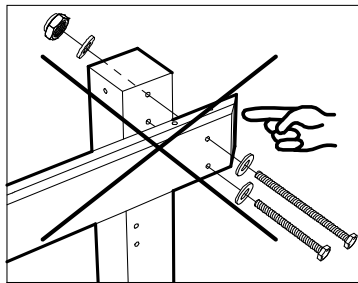
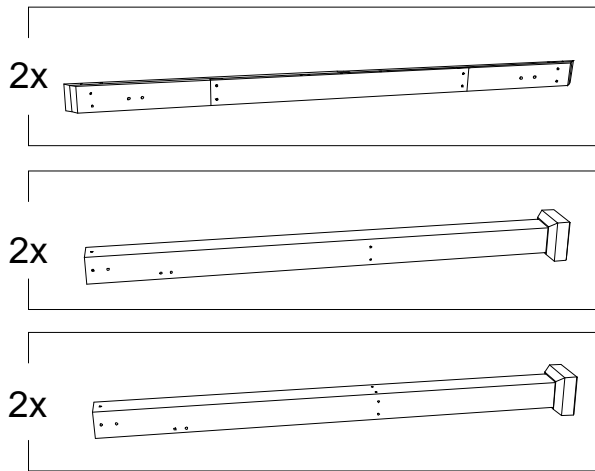

WARNING: It is important that the bolt holes on each Post 01 and Post 02 are facing the correct direction for both Step 5 and Step 14. Refer to Step 5 and Step 14 if unsure about correct orientation.

AVERTISSEMENT: Il est important que les orifices de chaque Poteau 01 et Poteau 02 se dirigent vers le sens exact pour les deux Étapes 5 et Étape 14. Consultez les Étapes 5 et 14 pour vous assurer de l'orientation exacte.

AVISO: Es importante que los agujeros de cada Poste 01 y Poste 02 se dirijan en el sentido adecuado para las dos Etapas 5 y Etapa 14. Consulte las Etapas 5 y Etapa 14 para asegurarse que se orientan adecuadamente.

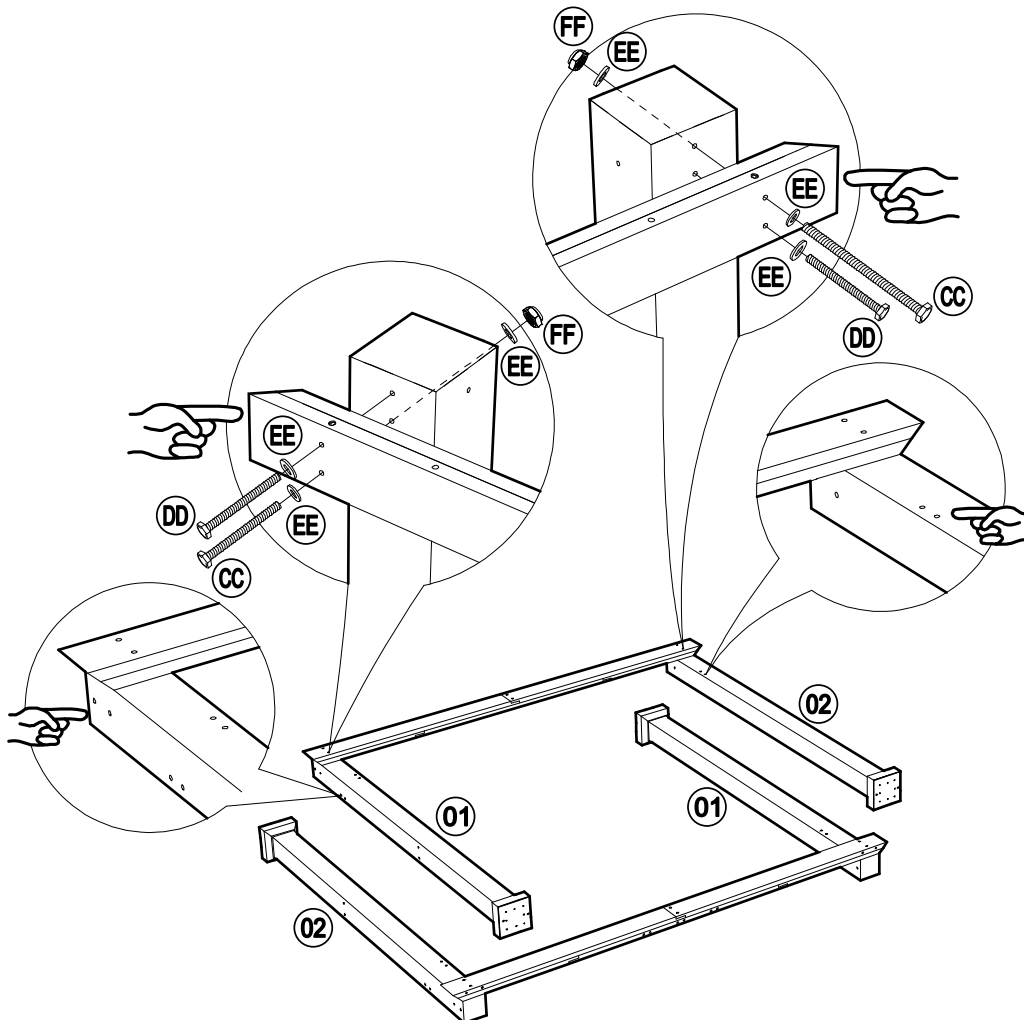

4

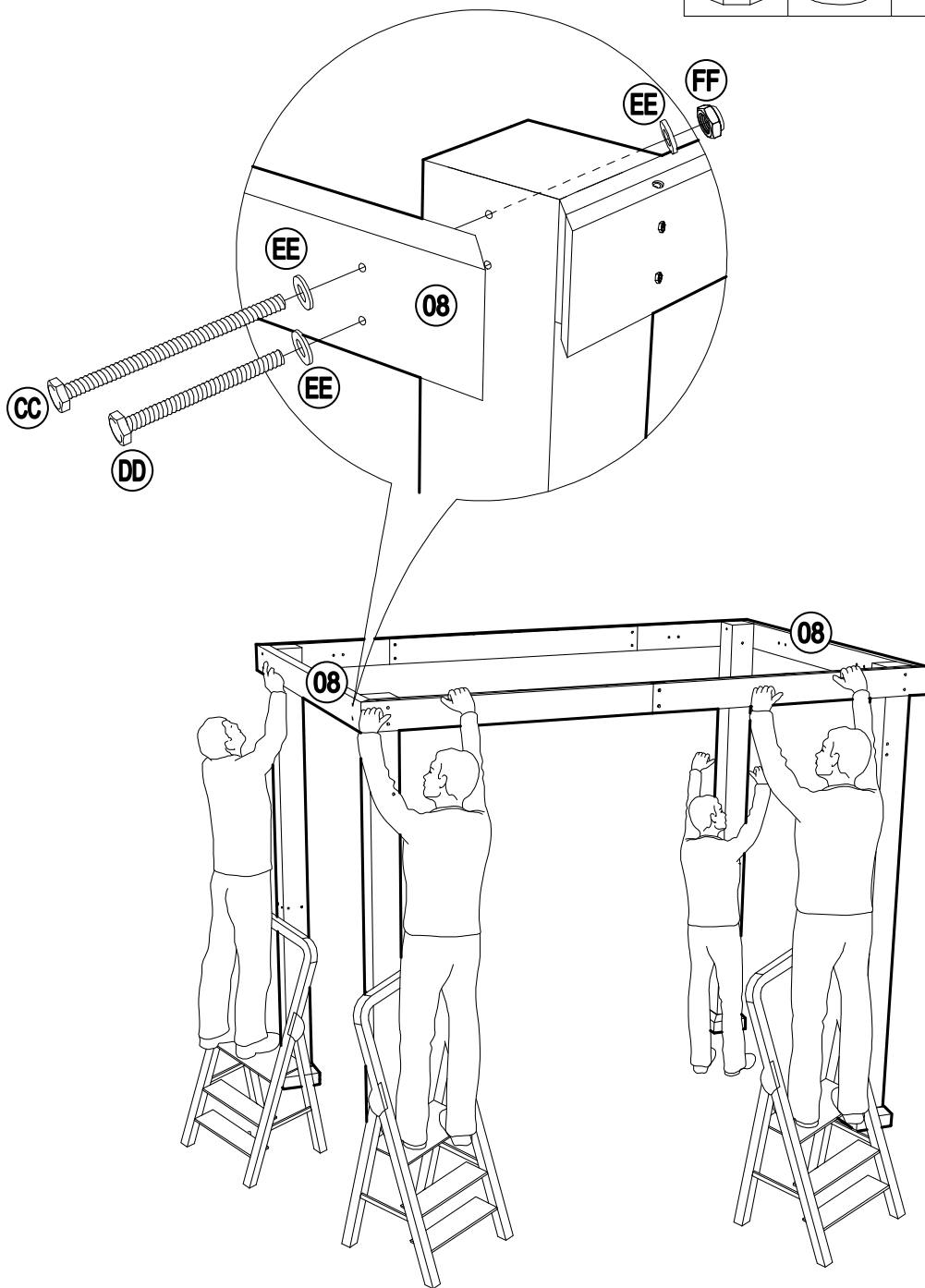
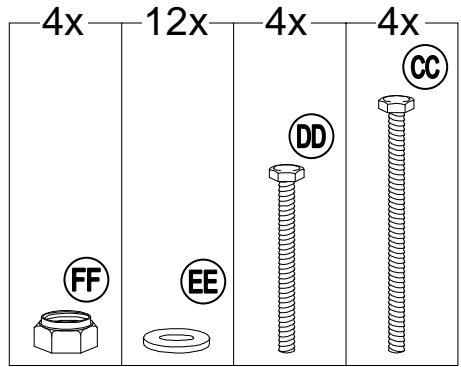
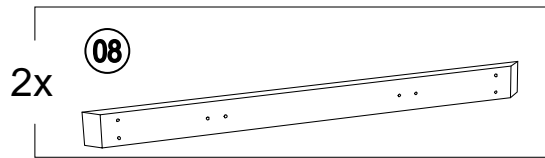

5

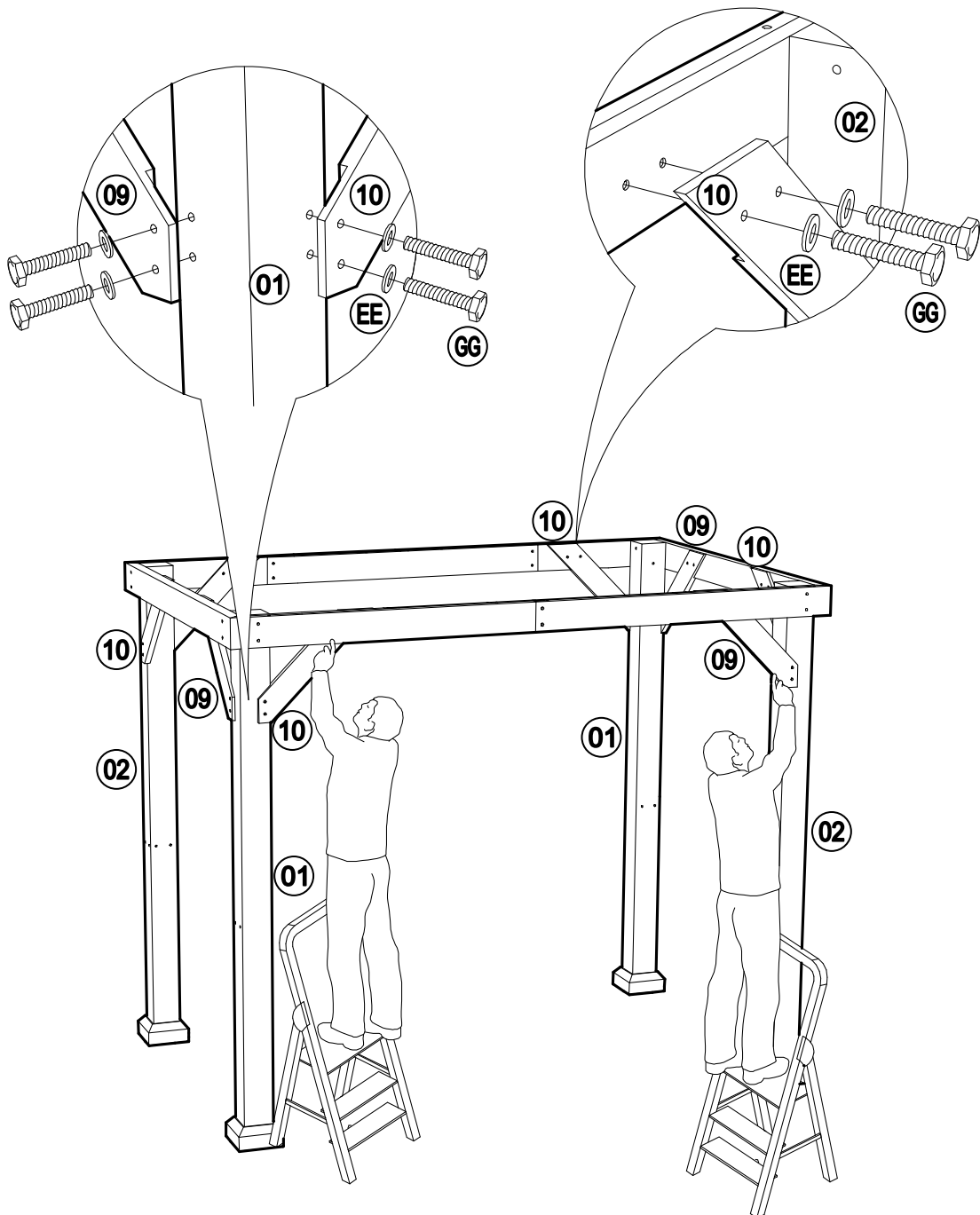
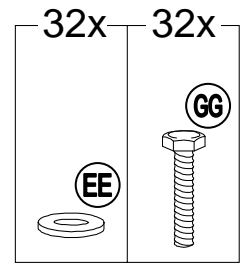
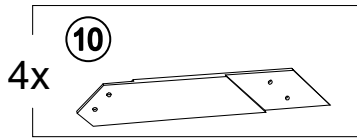
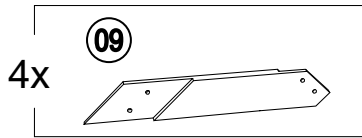

6

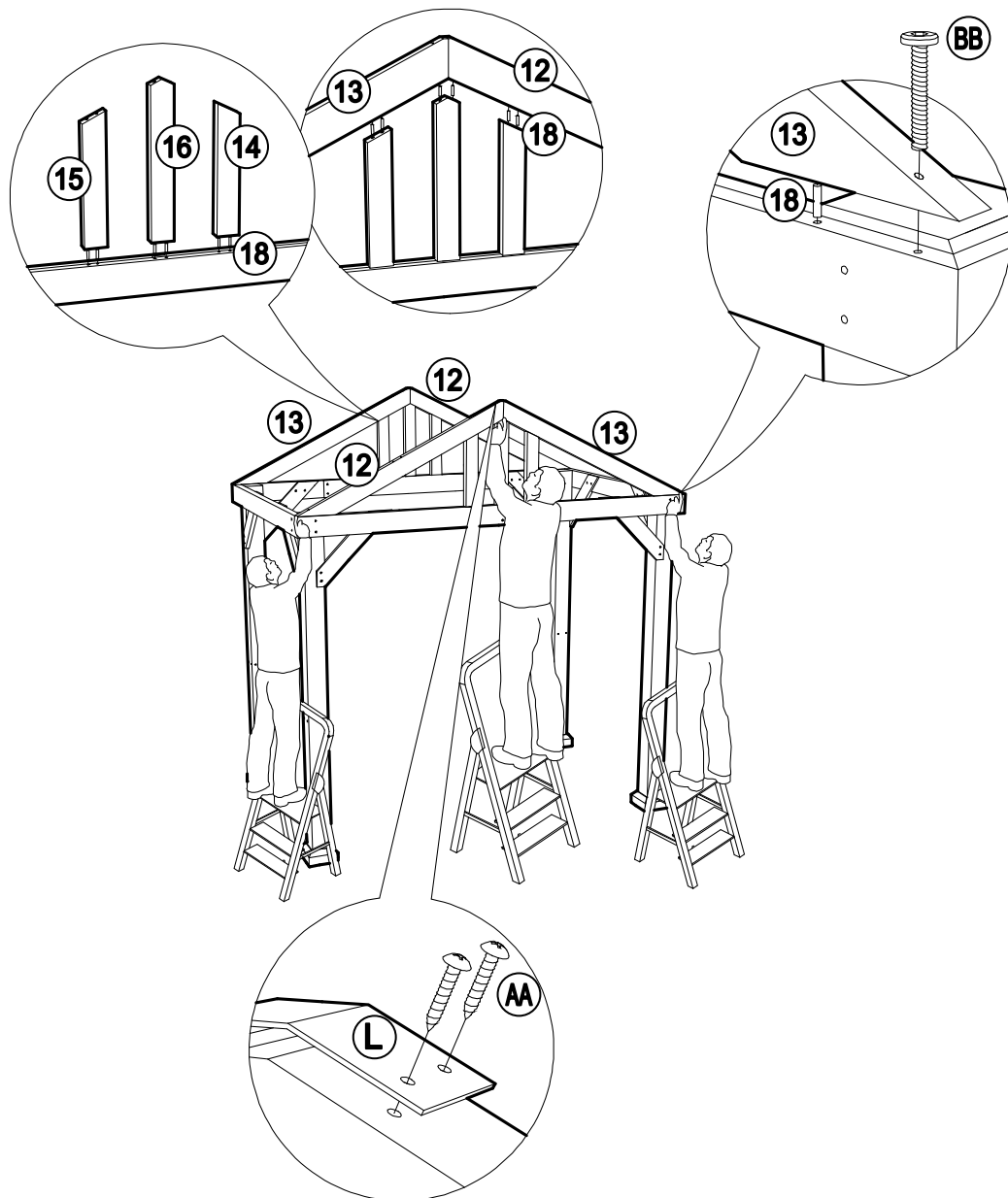
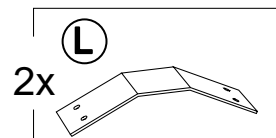
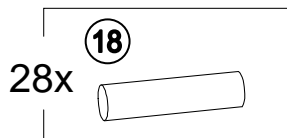
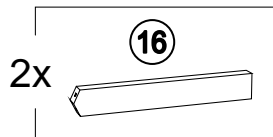
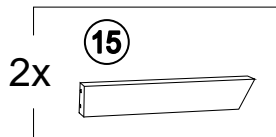
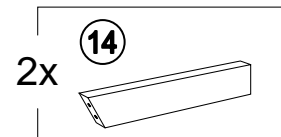
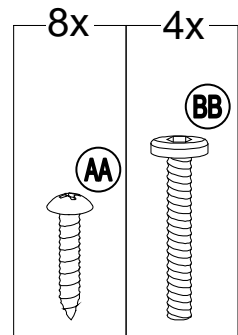
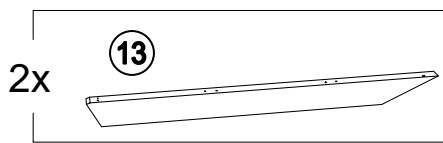
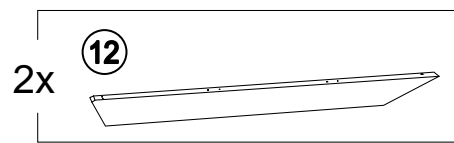

7

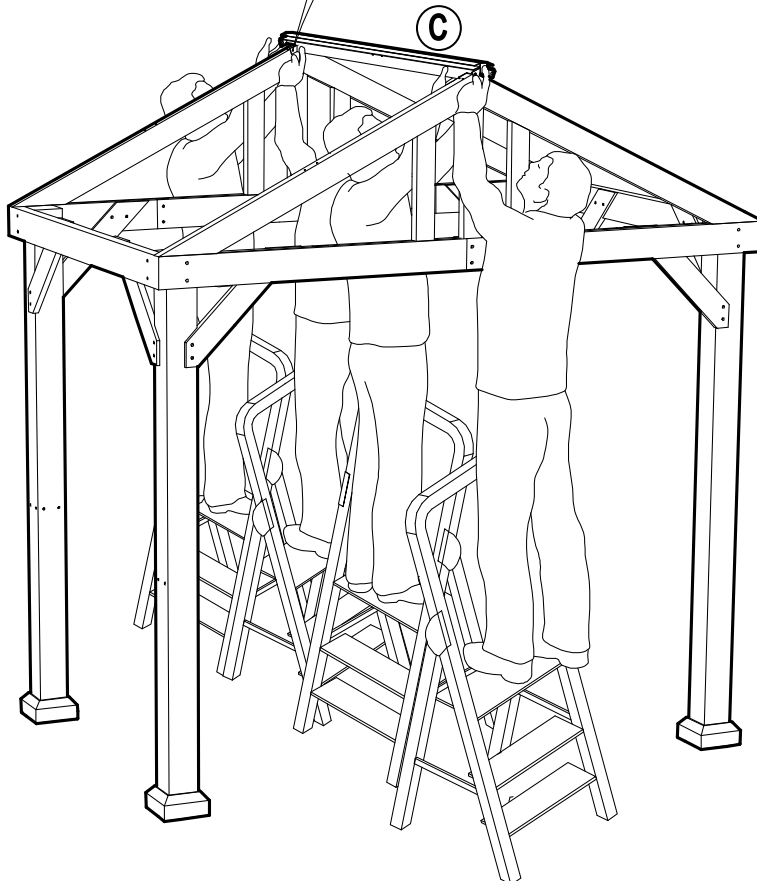
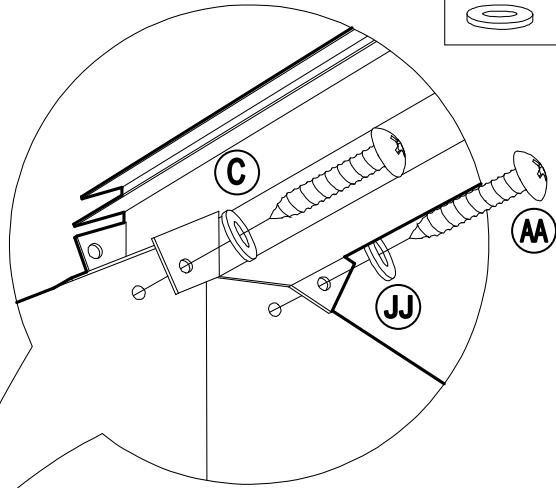
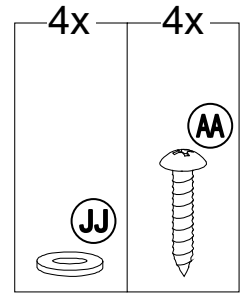
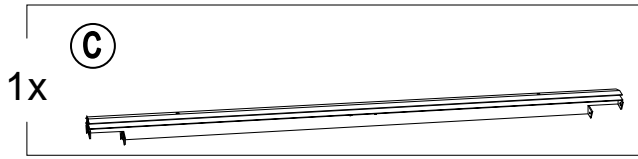

8

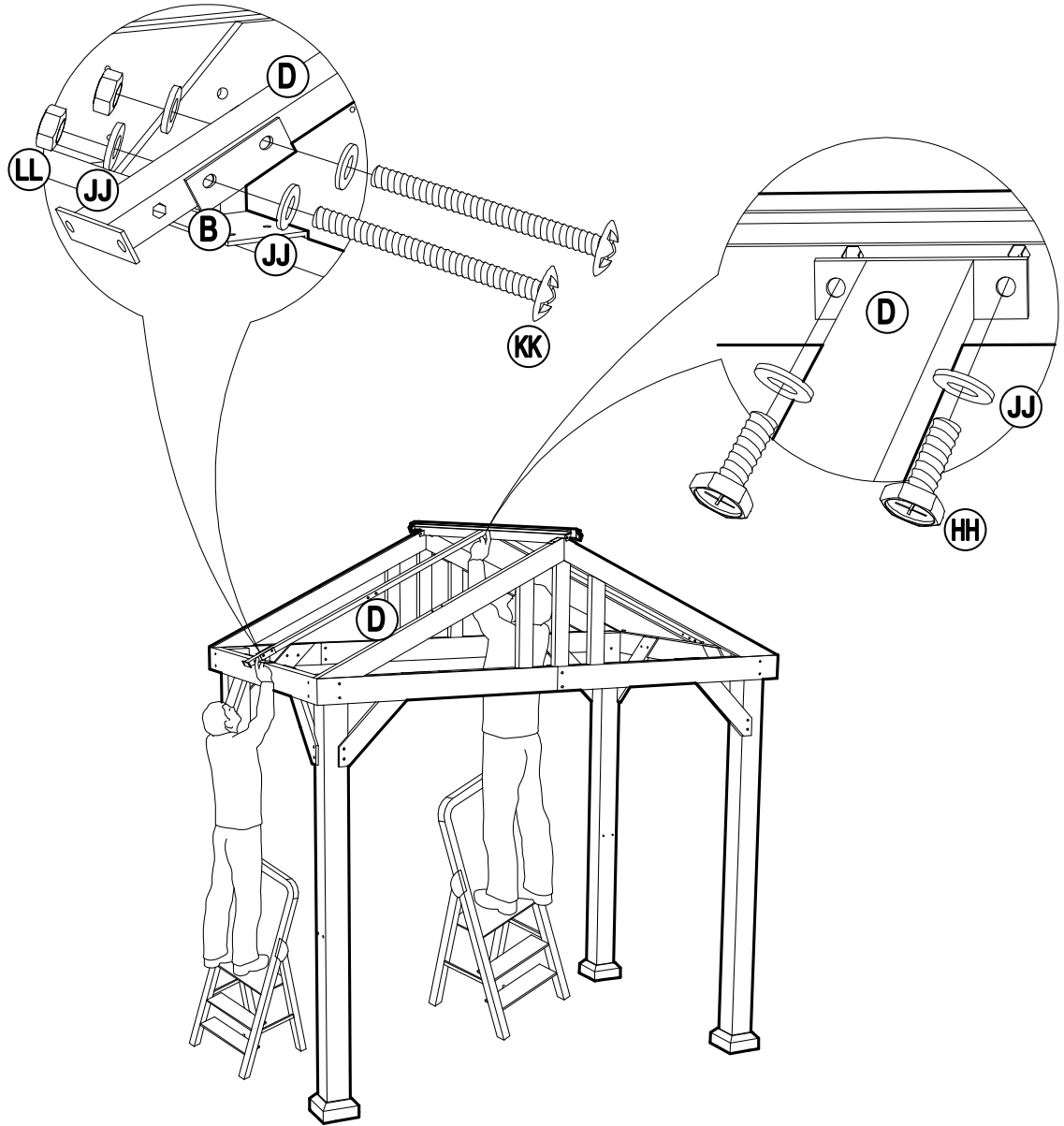
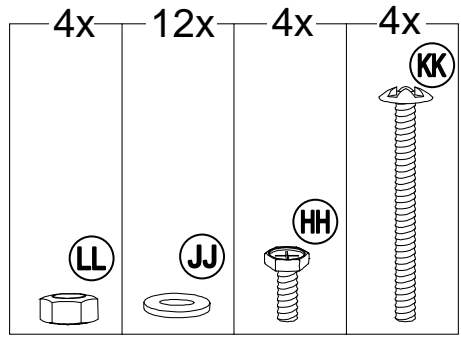
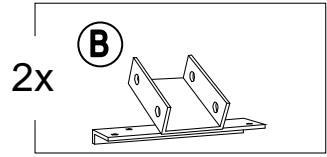
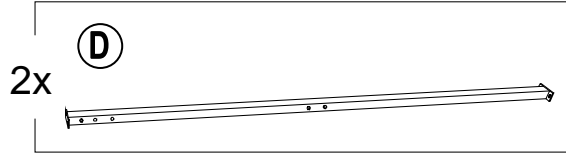

9

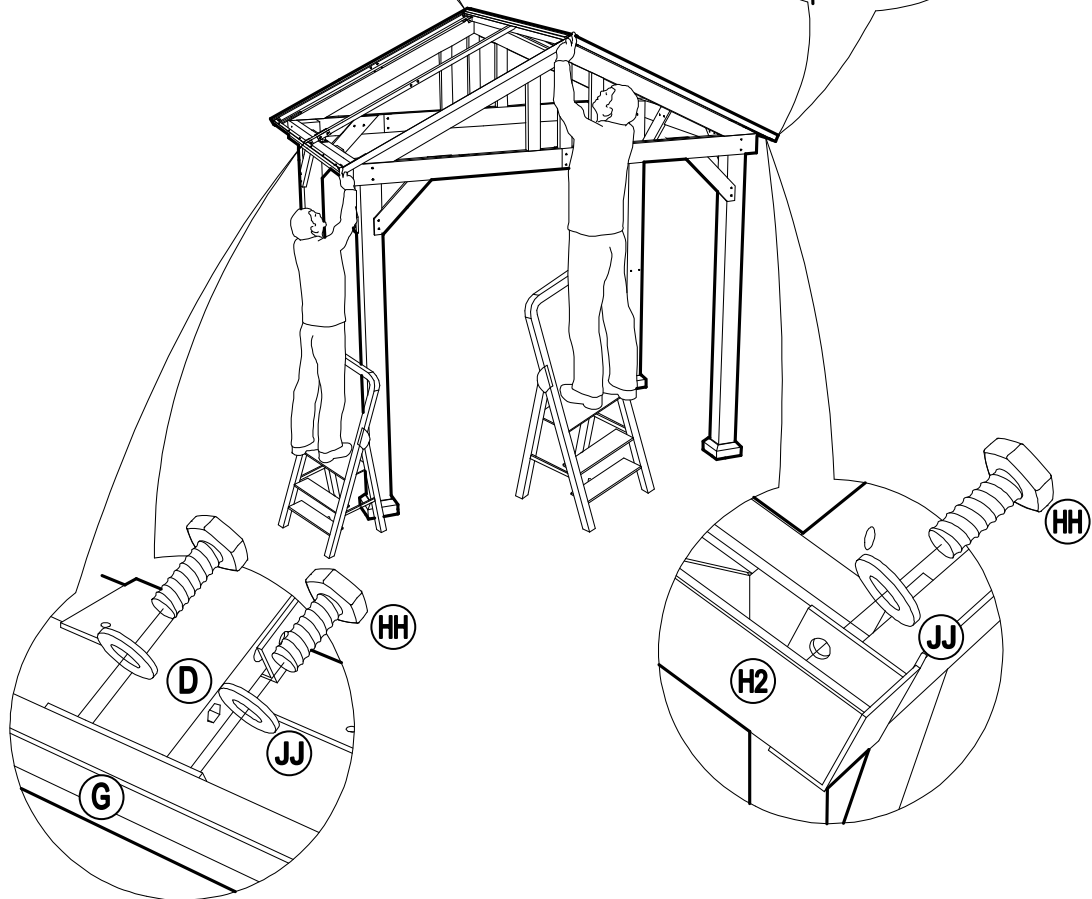
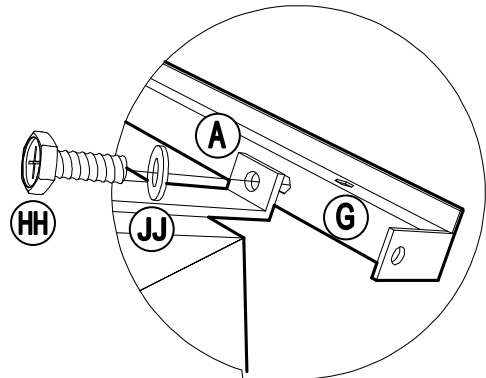
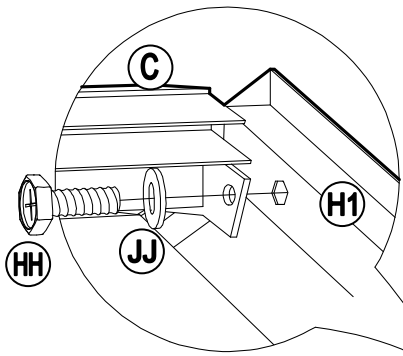
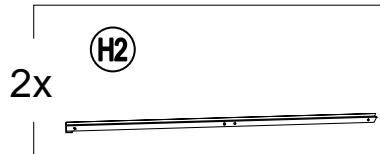
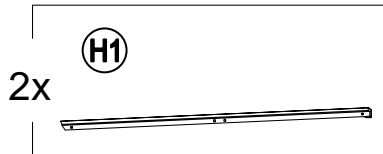
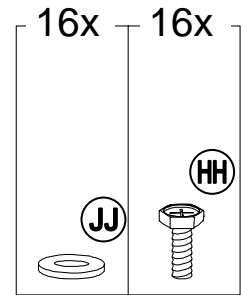
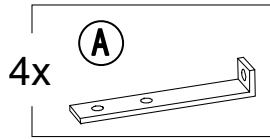
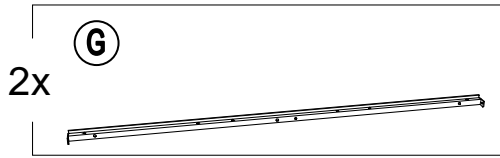

10

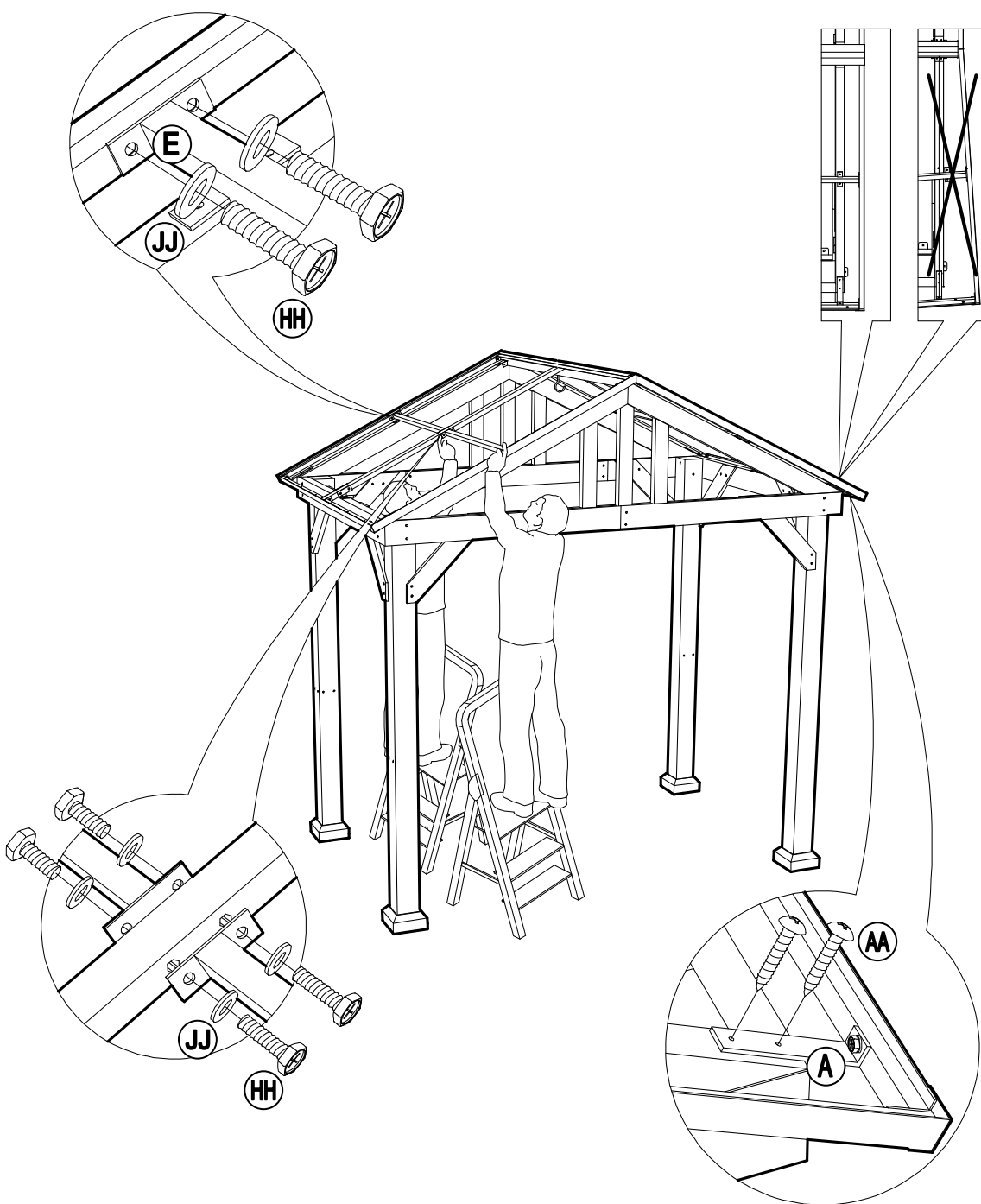
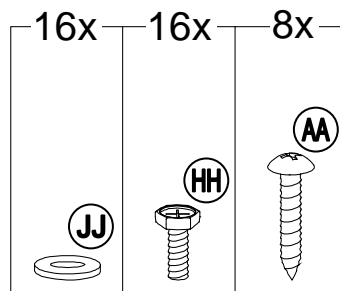
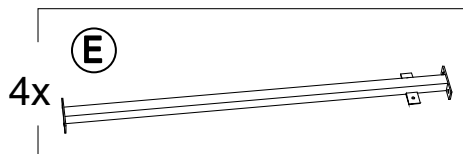

11

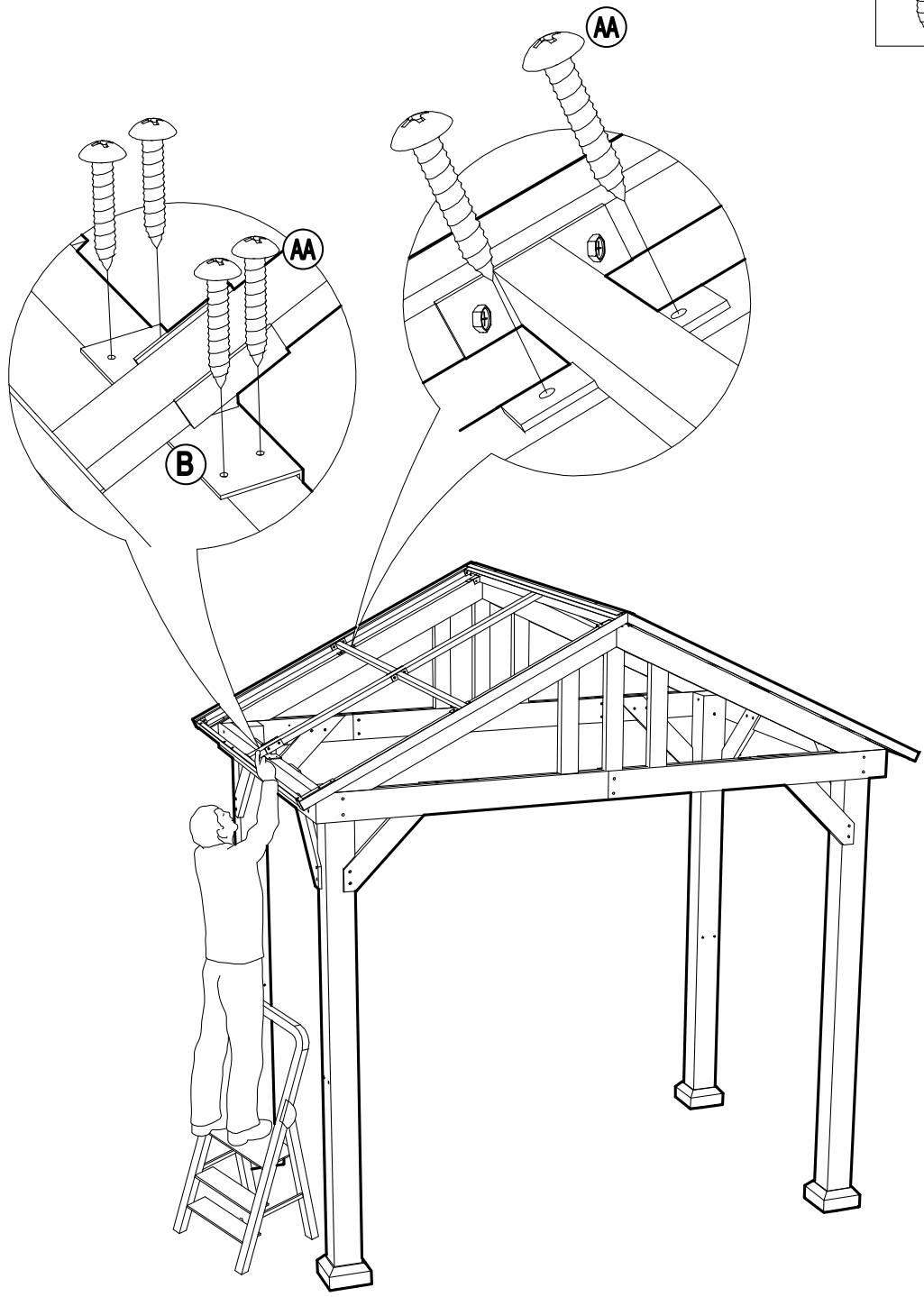
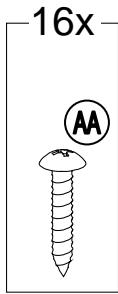

12

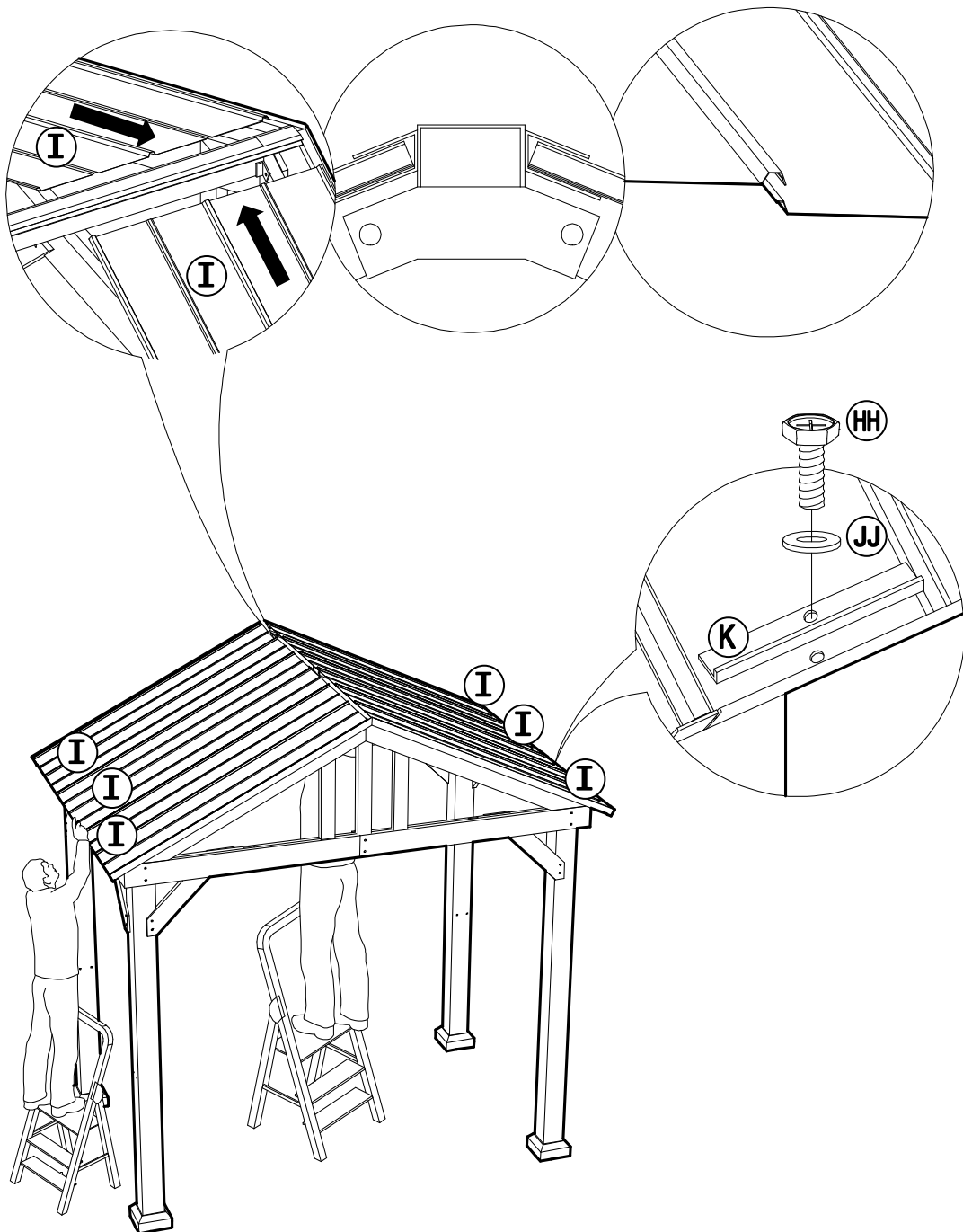
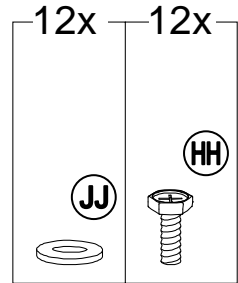
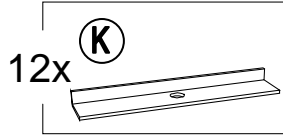
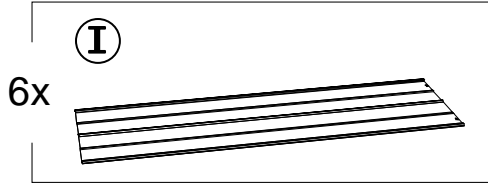

13

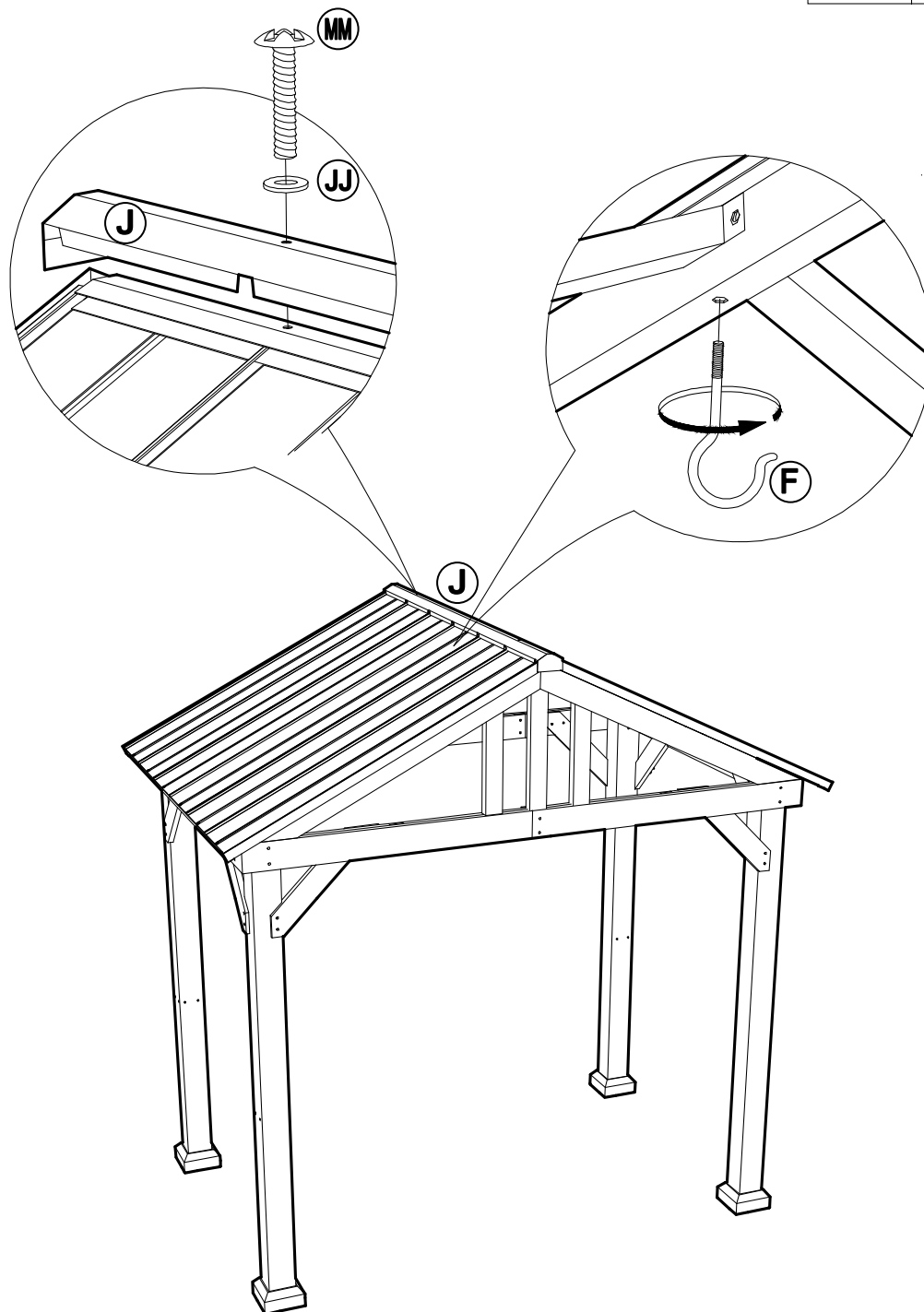
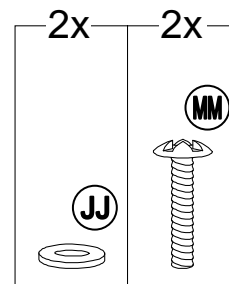
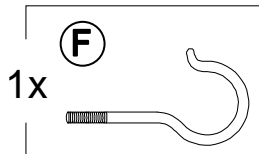
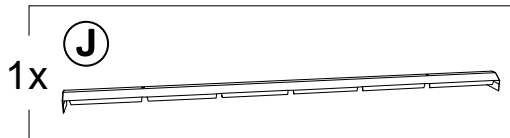

14

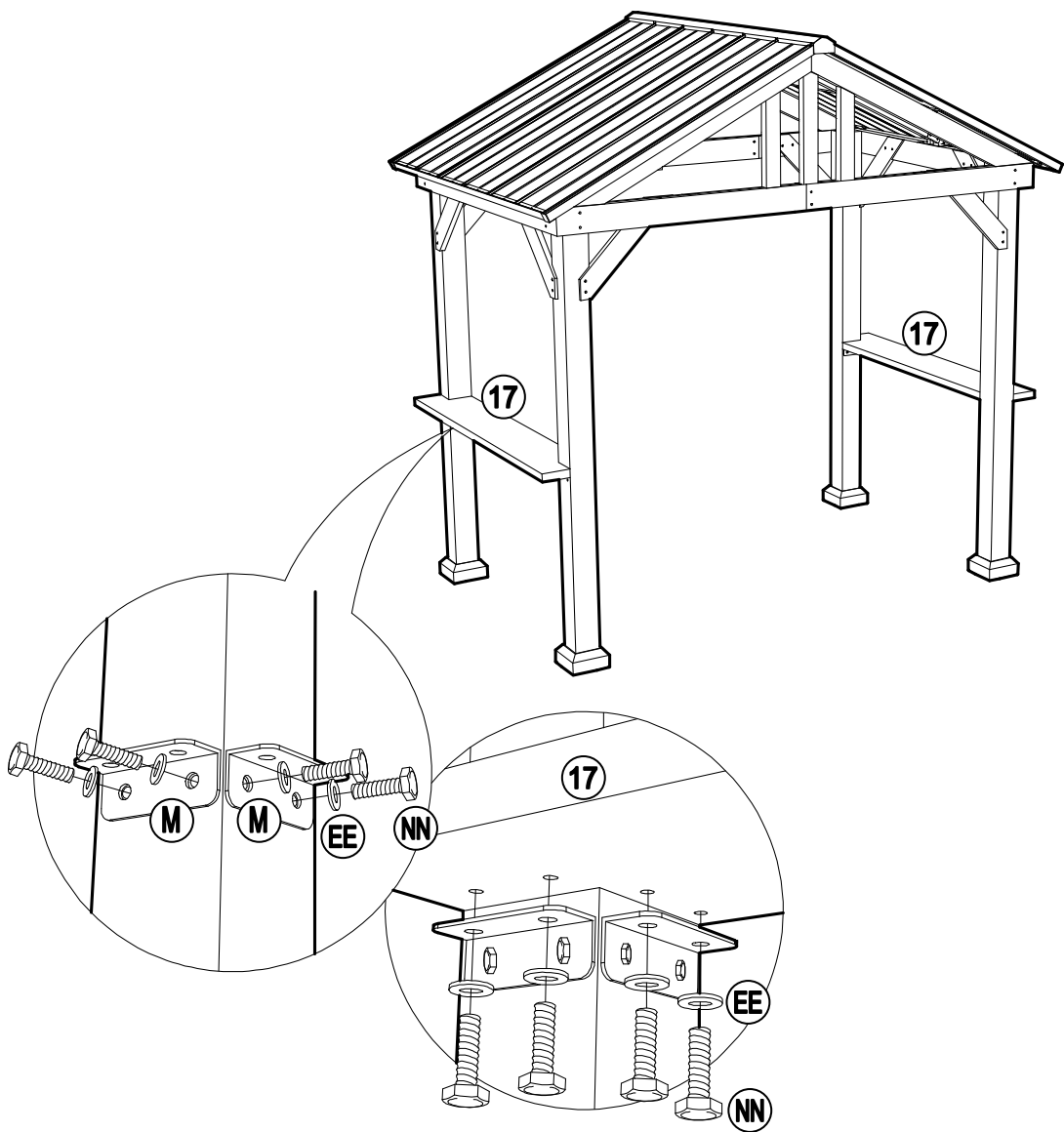
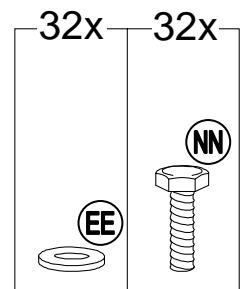
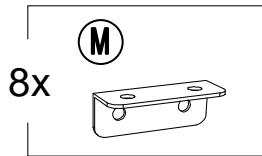
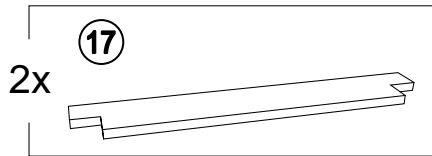

Care and Maintenance

- Our steel components for garden accessories and furniture are treated with rust inhibiting paint that protects it from rusting. However, due to the nature of steel, surface oxidation (rusting) will occur once these protective coatings are scratched. This is not a defect and thus not covered by the warranty.
- To minimize this condition, we recommend care when assembling & handling the product to prevent scratching the paint. Should any scratching or damage occur, we recommend immediate touch-up with rust inhibiting paint.
- Surface rust can also be easily removed with a very light application of common cooking oil. If surface oxidation (rusting) occurs and if no measure is taken to prevent this, the oxidation may start dripping on to deck or patio and caused damaging stains, which may be difficult to remove. This can be prevented if the above-mentioned measures are taken to keep the product from oxidizing.
- Use damp cloth to wipe off the stains as quickly as possible.
- If necessary, wash with a mild solution of soap and water; rinse thoroughly and dry completely.
- Periodically check and ensure that all bolts are well-tighten during use

Limited Manufacturer's Warranty

Sunjoy Group warrants to the original purchaser that this item is free from defects in workmanship and materials for a period of **1 year** from the date of purchase, provided the item was factory-sealed at the time of purchase and is maintained with care and used only for personal, residential purposes. Should any manufacturing defect arise within this warranty period, Sunjoy Group will replace (at our option) any defective merchandise or parts upon proof of purchase; however, transportation and delivery costs, as well as payments to a third party for assembly or disassembly of the item, remain the responsibility of the purchaser. A purchaser of an "open box," previously-returned, or "clearance" item, as well as original purchasers outside of the warranty period, may obtain replacement parts from Sunjoy Group for products in current production, at nominal cost.

Exclusions

Items used for commercial, contract, or other non-residential purposes, or items damaged due to acts of nature, vandalism, misuse, or improper assembly are not covered. Corrosion or rusting of hardware is not covered. Proof of purchase (dated register receipt) is required for warranty claims. Warranty is to the original purchaser and is non-transferable. Any replacement of warranted items will be in the original style and color, or a similar style and color if the original is unavailable or has been discontinued. As some states do not allow exclusions or limitations on an implied warranty, the above exclusions and limitations may not apply. This warranty gives you specific rights, and you may also have other rights, which vary from state to state.

Soin et Entretien

Avant d'utiliser, nettoyez le fauteuil complètement avec un chiffon sec et doux. Tandis que vous ne l'utilisez pas, nettoyez toute la saleté et les objets qui sont dessus, lavez avec une solution d'un savon doux et de l'eau ; rincez et séchez complètement. N'utilisez pas de détergents ou de nettoyeurs abrasifs. Après un temps les boulons et les écrous peuvent se desserrer. Vérifiez les boulons et les écrous de temps en temps et resserrez-les si c'est nécessaire.

Garantie limitée du fabricant

SUNJOY Group garantit à l'acheteur d'origine que cet article est exempt de défauts de fabrication et de matériaux pour une période d'un an à compter depuis la date d'achat, pourvu que l'article soit scellé de fabrique au moment de l'achat et qu'il soit entretenu avec soin et utilisé uniquement à des fins personnelles et résidentielles. Si un défaut de fabrication survient dans cette période de garantie, SUNJOY Group remplacera (à notre discrétion) toute marchandise ou pièce défectueuse en montrant une preuve d'achat; cependant, les frais de transport et de livraison, ainsi que les paiements à quelconque pour le montage ou le démontage de l'article, seront la responsabilité de l'acheteur. Un acheteur d'une "" boîte ouverte "" précédemment retournée, ou un article "" en liquidation "" , ainsi que les acheteurs originaux en dehors de la période de garantie, peuvent obtenir des pièces de rechange de SUNJOY Group pour les produits en production actuelle, à un prix actuel.

Exclusions

Les articles utilisés pour des fins commerciales, sous contrat, ou d'autres fins non- résidentielles, ou les articles abimés par les intempéries, le vandalisme, l'utilisation abusive, ou le montage incorrecte ne sont pas couverts. La corrosion et la rouille de la quincaillerie ne sont pas couvertes. Une preuve d'achat (reçu date) sera requis pour toute réclamation sous garantie. La garantie n'est que pour l'acheteur d'origine et n'est pas transférable. Tout remplacement d'articles garantis seront du style et de la couleur original, ou d'un style et couleur similaire si l'original n'est pas disponible ou s'il a été discontinué. Puisque certains états ne permettent pas les exclusions ou les limitations sur une garantie implicite, les exclusions et limitations ci-dessus peuvent ne pas s'appliquer. Cette garantie vous donne des droits spécifiques, et vous pouvez également avoir d'autres droits qui varient d'un état à un autre.