



MAGS

BATTERY POWERED
PERMANENT-ELECTRO
MAGNETIC LIFTER



MAGS

MAGS is the new battery-operated permanent-electro magnetic lifter for handling ferrous loads in Industry 4.0 environment.

Practical and quick to use, in just a few seconds it clamps the load from the top, without deforming or compressing it. High-performance batteries make it independent of the power supply and usable anywhere.

The innovative FRS technology compares the magnetic force and weight of the load in real time, enabling safe handling operations.



Compact and lightweight



MAGS offers an exceptional weight/performance ratio. Easy to handle, it has a steel frame that combines lightness, convenience and mechanical strength. The handle that runs 360° around the module provides protection against accidental impacts.



Flexible and efficient

The permanent-electro magnetic technology with square poles optimises the contact surface with the load and thus concentrating the magnetic force to maximise performance and safety.

The 10 magnetisation levels allow loads of different thicknesses and types to be handled, from sheet metal to forged blocks.



Safe and innovative



MAGS is equipped with FRS (Force Reading System). With FRS you always know how strongly each load is held by the magnet: the built-in load cell compares the magnetic force with the weight. If the safety conditions are not satisfied, MAGS alerts and stops the operation. FRS checks AUTOMATICALLY the magnetic force, the weight to be lifted, the condition and the surface of the load. The operator operates in complete safety. MAGS takes care of everything!

MAGS

MAGS is the optimal solution for handling ferrous loads in carpentry, service centres, for loading and unloading parts on machine tools and in many other contexts.



Mechanical workshops



Mould making



Sheet metal storage



Cutting centres



Steelworks



Shipyards



Automation



Logistics



Anywhere use



MAGS is powered by innovative supercapacitors that last more than a week: are quick to recharge and last for more than 10 years without maintenance.

MAGS can also operate outdoors, on cranes or forklift trucks, without being conditioned by the presence of power connection.



Always under control

The electronic control system memorizes each operation, checks the conditions and communicates any faults. It can operate automatically connected to other machines, through Modbus TCP/IP protocol via Ethernet and Modbus RTU.



Modular and scalable



For larger loads or heavier weights, it is possible to associate several MAGS with each other to adapt to the morphology of the load and to make several modules communicate and activate them remotely with a single command.

Industry 4.0 compliant

MAGS is designed for interconnection with the factory logistics system and can be interfaced with the crane or automated handling systems.

The internal memory records all operations while the collected data can be easily consulted connecting via a common USB cable to a PC. You can check the usage rate and keep track of any misuse.



MAGS B800

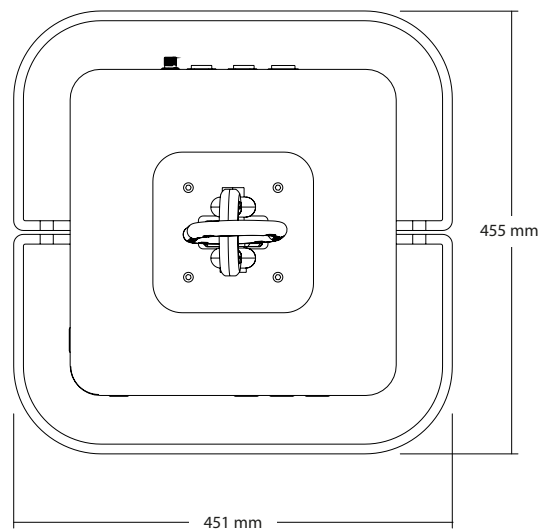
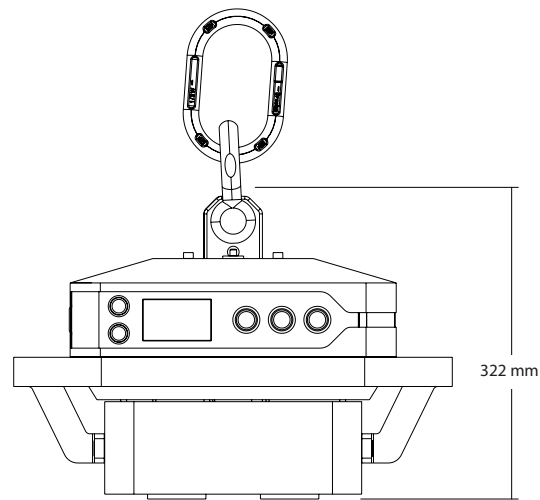

MAGS B1600

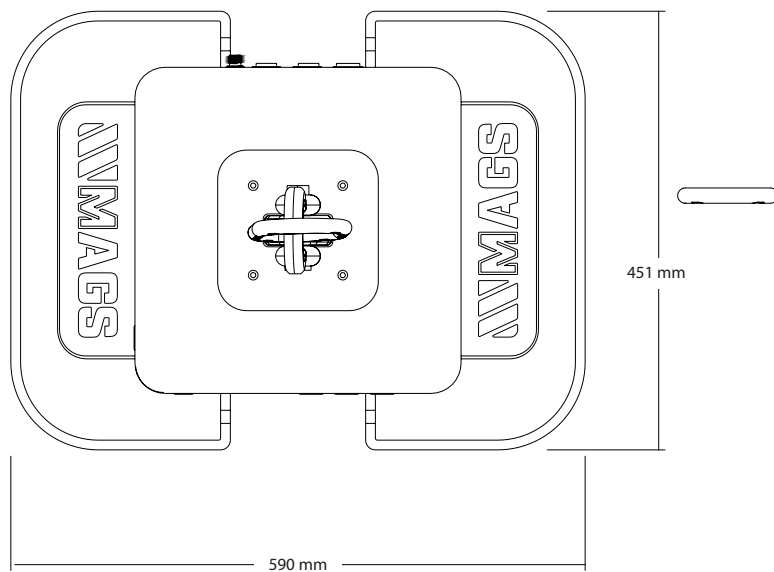
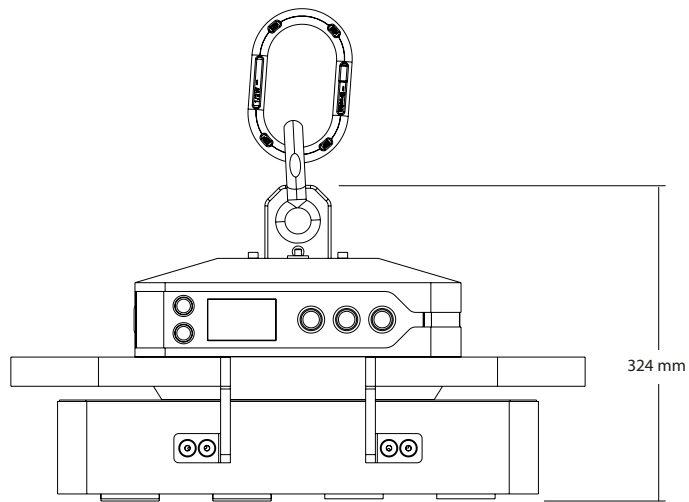

MAGS

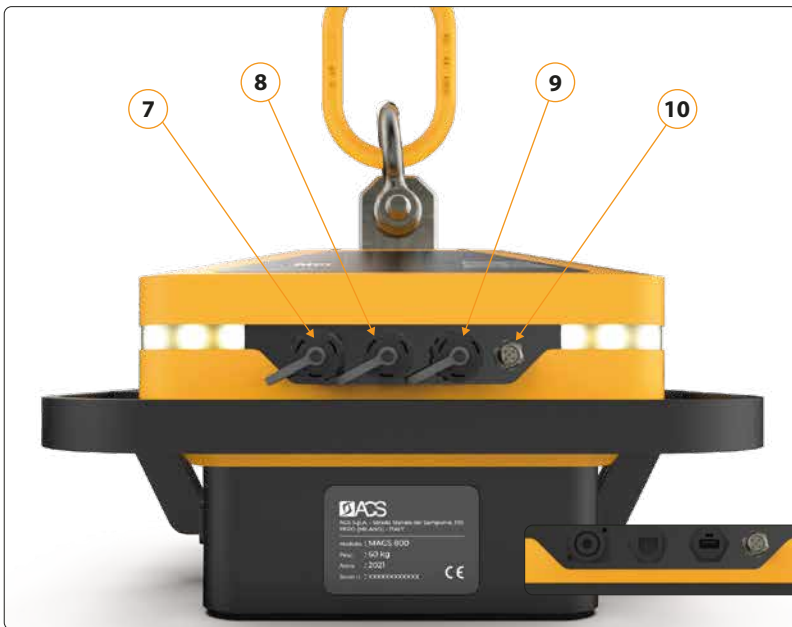
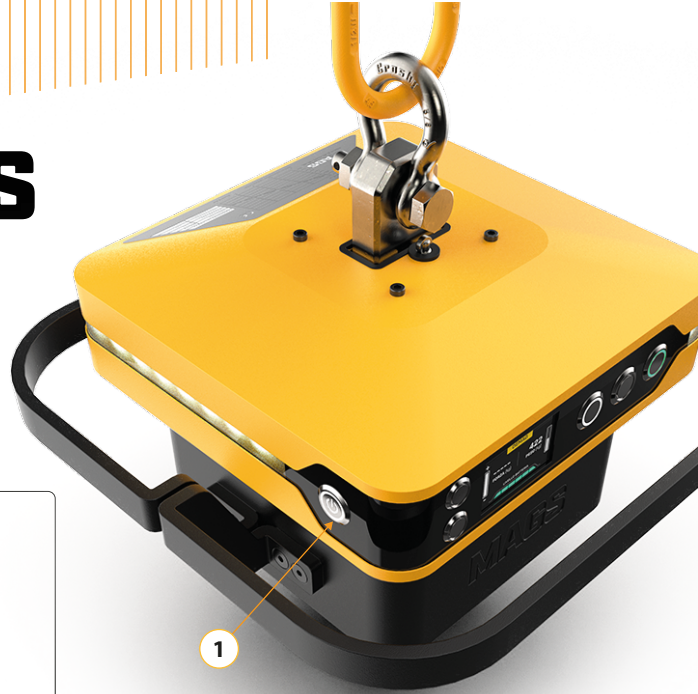

1. ON/OFF button
2. Colour TFT display
3. Demagnetisation button
4. Safe button
5. Magnetisation button
6. Level selection buttons
7. Battery charger power socket
8. Ethernet socket
9. USB socket
10. Serialisation connector

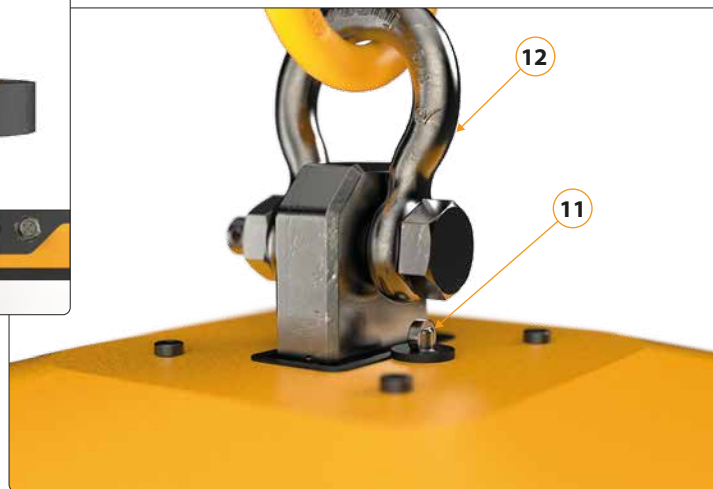

11. ADS - Load release prevention system
12. Shackle and hook bell (included)

MAGS

TECHNICAL DATA

Dimensions and weight	MAGS B800	MAGS B1600
Magnetic base dimensions	264x264x100 mm	494x264x100 mm
Overall dimensions	451x455x322 mm	590x451x324 mm
Weight	60 kg	90 kg

Load capacity	MAGS B800	MAGS B1600
Maximum load capacity (plate)	800 kg - Safety factor 1:3	1600 kg - Safety factor 1:3
Length	from 250 mm to 2000 mm	from 250 mm to 3000 mm
Width	from 250 mm to 2000 mm	from 250 mm to 2000 mm
Minimum thickness	4 mm	4 mm

Power feeding	
Technology	Supercap
Recharge cycles	>10.000 (approx 2.000.000 mag/demag operations)
Autonomy	Over 500 operating cycles
Recharge time	10 min (autonomy \approx 50 cycles) - 90 min (full recharge)
Recharge voltage	110/240 Vac with dedicated battery charger

Main features	
Safety systems	Built-in load cell Real-time magnetic force reading sensor ADS: Load release prevention system Cycle log - time and number of activations
External connection interfaces	Modbus RS-485 Digital I/O Ethernet - Modbus TCP/IP (Industry 4.0 compliant)
Operator interfaces	3.2" TFT graphic display Backlit buttons with tactile feedback 360° LED bar with status indications Radio remote control (on request)
Other features	10 selectable magnetisation levels for different load thicknesses Battery status indication Protection and handling handle Serializable for modular compositions Made in Italy



Advanced Global Solution A.G.S. S.p.A. reserves the right to make technical changes connected to technological progress at any time.



MAGS_2022_05_EN

MAGS

IS A PRODUCT OF ADVANCED GLOBAL SOLUTION A.G.S. S.p.A.

📍 SS del Sempione 170, 20016 Pero (MI) 📞 +39 02 94 55 40 00 🌐 agsmags.com

