

4048 HIGH FLOW PUMP

Name	Model # OEM/Aftermarket	Voltage	Dimension	Flow Rate	Amps (Max.)	Shut-Off Pressure
4048	4048-153-A75 (4048-153-E75)	12 VDC	10.3" x 4.9" x 4.8" [260 x 125 x 122 mm]	4 GPM [15 LPM]	10	55 PSI [3.8 BAR]

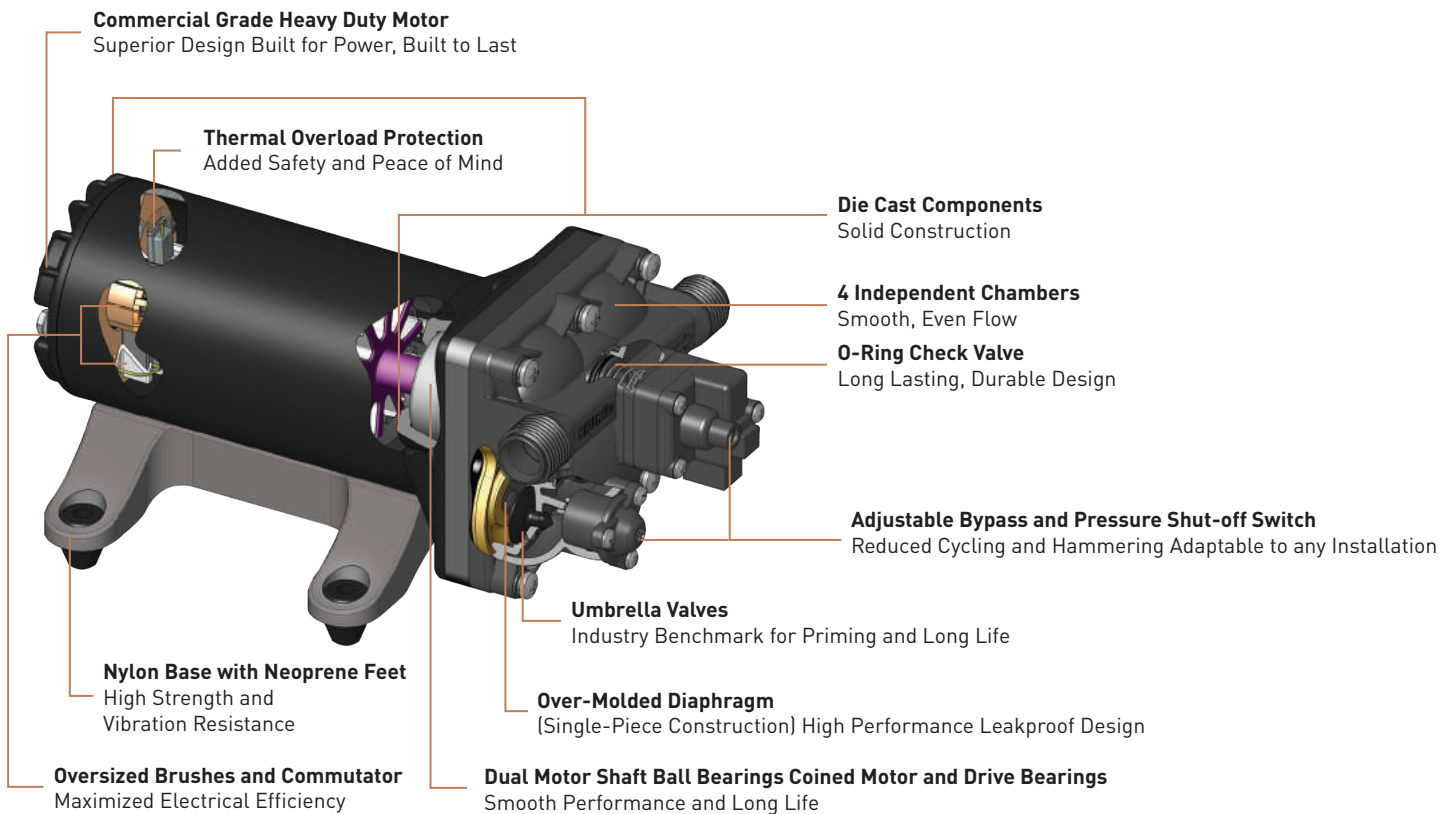

With flow reaction technology, the Shurflo High Flow fresh water pump has a unique one-piece diaphragm and internal by-pass to assure smooth flow, long life and top performance in any plumbing system. Designed and built for high flow, low noise, smooth flow with no rapid cycling and Shurflo reliability, this fresh water demand pump is quiet and can run dry without damage. Mounts in any position. This pump is designed to replace both the 4900 and 5900 smart sensor series products.



SLV SINGLE FIXTURE AUTOMATIC DEMAND PUMP

Name	Model # OEM/Aftermarket	Voltage	Dimension	Flow Rate	Amps (Max.)	Shut-Off Pressure
SLV	105-003 (105-013)	12 VDC	6.8" x 3.9" x 2.5" [170 x 100 x 60mm]	1 GPM [3.8 LPM]	2.5	30 PSI [2.0 BAR]



This compact automatic demand fresh water pump offers durability and dependability making it ideal for low volume, intermittent duty applications. The SLV pump self-priming up to 2.5 vertical feet while delivering 1.0 GPM at open flow. The 12 volt low power consumption motor, equipped with thermal protection and a long life pressure switch rated to 30 PSI, provides high pump performance and reliability.

PUMP REPAIR AND REBUILD KITS

4048 SERIES

Name	Model # OEM/(Aftermarket)	Switch	Upper Housing	Valve Assembly	Drive Assembly	Motor	Pump Head Kit	Check Valve
		1	2	3	4	5	1, 2, 3, 4	Not Shown
4048 - 12 VDC	4048-153-A75 (4048-153-E75)	94-801-05	94-801-01	94-800-01	94-801-02	94-71-001-07	94-801-04	94-800-03

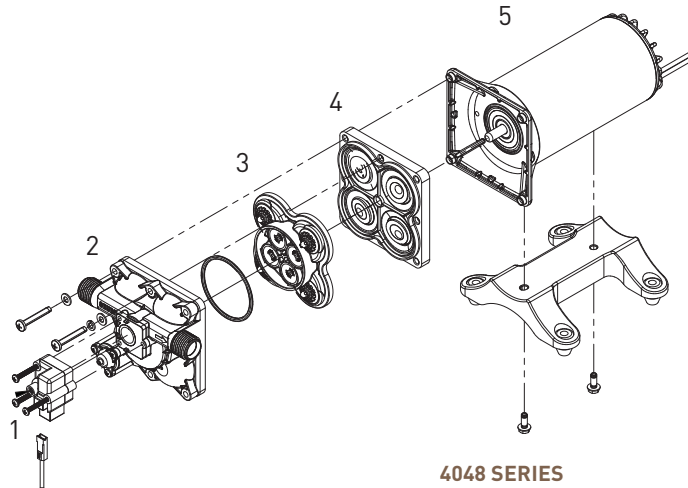

8050 SERIES

Name	Model # OEM/(Aftermarket)	Pump Head	Switch	Check Valve	Upper Housing	Valve Assembly	Drive Assembly
		1	2	3	4	5	6
Utility Pumps	8050-305-XXX	N/A	N/A	N/A	N/A	94-391-12	94-385-42

