



BRAKE CONTROLLER COMPANY



ELECTRONIC BRAKE CONTROLLER
HAYES BRAKE CONTROLLER P/N 81770

INSTALLATION MANUAL

For trailers with 2-8 electric brakes and vehicles with 12 volt negative ground systems only.

READ AND SAVE THESE INSTRUCTIONS

- Before beginning installation, read and become familiar with these instructions.
- Leave in tow vehicle for future reference.
- **IMPROPER INSTALLATION AND OPERATION COULD CAUSE PERSONAL INJURY, AND/OR EQUIPMENT AND PROPERTY DAMAGE**
- Questions on installation, adjustment, trouble shooting or operation of brake controllers Call **800-892-2676** Monday through Friday between 8:00 a.m. and 5:00 p.m. Eastern Time.

SAFETY INFORMATION



WARNING: Indicates a potentially hazardous situation that, if not avoided, could result in death or serious personal injury.



CAUTION: Indicates a potentially hazardous situation that, if not avoided, could result in damage to product or property.



TIP: Contains helpful information to facilitate installation.

Installation



CAUTION:

- In the automatic and minimum power setting at 10, noticeable braking is applied only when the sensor detects deceleration.
- With the vehicle at rest and the brake pedal depressed, there should be only a slight output to the trailer brakes (when minimum power is set to 10).
- Higher at rest outputs and reverse output can be obtained by increasing the minimum power setting.

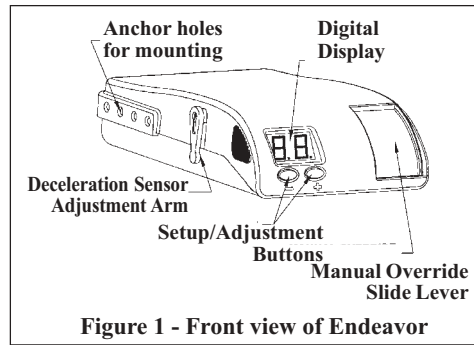

Figure 1 - Front view of Endeavor

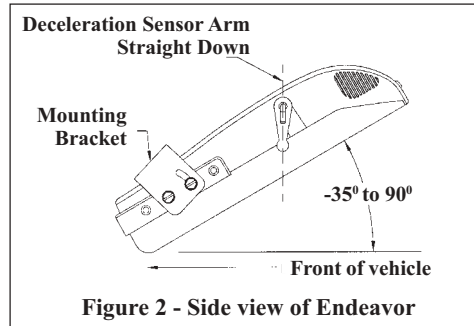

Figure 2 - Side view of Endeavor

Mounting angle

Mounting angles between -35 and + 90 degrees can be accommodated by the controller. **THE UNIT MUST, HOWEVER, BE INSTALLED SO THAT IT IS PARALLEL WITH THE TRAVEL OF THE TOW VEHICLE AND TRAILER.**

Controller Mounting and Installation

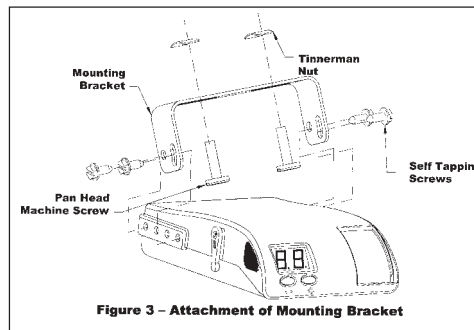

Figure 3 - Attachment of Mounting Bracket

Controller and Mounting Bracket

- The bracket provided is to be used for mounting the controller to the tow vehicle.
- Use the reversible slotted bracket.
- **DO NOT MOUNT CONTROLLER UPSIDE DOWN OR SIDEWAYS.**



WARNING:

If the controller is mounted incorrectly, the deceleration sensor cannot operate correctly and may cause loss of braking.

Installation Steps

1. Install the mounting bracket to a solid surface under the tow vehicle dash using the two machine screws and fasteners provided. Tighten until snug. See **Figure 3 - Attachment of Mounting Bracket.**
2. Insert four of the self tapping screws provided through the mounting bracket holes and into the desired controller anchor holes. Tighten until snug.
3. **Mount in a location which allows the driver to easily apply the manual override slide lever and see the digital display.**



WARNING:

Use of longer screws than those provided can damage the unit and cause loss of braking.



WARNING:

- All four controller wires must be connected properly for the controller to operate correctly.
- Failure to properly connect all four wires can cause loss of trailer braking.
- Improper wiring will destroy the controller and void the manufacturer's warranty.



CAUTION:

- Care must be taken to ensure that the mounting surface is rigid enough to prevent excessive vibration.
- Excessive vibration may result in poor performance.

Read ALL wiring instructions prior to making electrical connections to the tow vehicle.



WARNING

To reduce the risk of injury or damage to property:

- Always connect the **white wire first** and the **black wire second.**
- All four controller wires must be connected properly for the controller to operate correctly.
- Failure to connect the wires correctly can cause loss of trailer braking.



WARNING:

- The white wire must be connected to a known good ground (preferably the negative battery post).
- Improper or no ground will result in poor controller performance or lack of performance altogether.
- Improper ground connection can destroy the controller and void the factory warranty.



WARNING:

- Improper connections may result in no trailer brakes or destroy the controller and void the manufacturer's warranty.
- Refer to the vehicle manufacturer or Hayes Brake Controller (1-800-892-2676) for the latest controller red stoplight wire to stop lamp switch connections.



WARNING:

Follow wiring instructions.

- Improper wiring will destroy the controller and void the manufacturer's warranty.



CAUTION:

- **DO NOT** connect the black wire to any vehicle power supply line or fuse panels that could cause circuit overload or damage to tow vehicle wiring and vehicle electronics.
- Route the black wire through a grommet hole in the fire wall to prevent grounding and away from the radio antenna to reduce any possible AM radio interference.



TIP:

• Special Dual - Mated “Quik-Connect™” Wiring Harnesses are available for all Hayes Brake Controllers fitted with a connector on the wire leads, making connection a snap. Harnesses are available through all dealer resources. Ask specifically for the Hayes Brake Controller Company (HBCC) brand harnesses to match your controller.

The following chart describes the function of each of the controller’s wires:

Order	Color	Function	Wire Size (AWG)	Connect To
1st	White	Ground	16	grounded metal part of the firewall or directly to the negative (-) terminal of the battery. Connect this wire first.
2nd	Black	+ connection to the vehicle’s power system	12	positive (+) terminal of the battery. MUST have a self-resetting Circuit Breaker in-line between the controller and the battery. See chart for proper size. Route the black wire through a grommet hole in the fire wall to prevent wire grounding and away from the radio antenna to reduce any possible AM radio interference. Connect this wire second.
3rd	Red	Stoplight	14	non-powered stop lamp wire (of the stop lamp switch) or trailer tow wiring harness. It is recommended that a 20-amp inline fuse be installed between the controller’s red wire and the stop lamp switch. The fuse is required in 1999 & later Fords.
4th	Blue	Output to trailer brakes.	12	the trailer brake wire or tow vehicle / trailer connector.

IMPORTANT: Make all controller wiring connections to the wiring harness before connecting the harness to the vehicle.
SELF-RESETTING CIRCUIT BREAKER SIZE CHART

Number of Brake Light Bulbs (tow vehicle Plus trailer)	Number of Trailer Brakes			
	2 Brakes	4 Brakes	6 Brakes	8 Brakes
4 Bulbs (minimum)	20 AMP	30 AMP	30 AMP	40 AMP
5 Bulbs	20 AMP	30 AMP	30 AMP	40 AMP
6 Bulbs	20 AMP	30 AMP	40 AMP	40 AMP
7 Bulbs	30 AMP	30 AMP	40 AMP	40 AMP
8 Bulbs	30 AMP	30 AMP	40 AMP	50 AMP
9 Bulbs	30 AMP	40 AMP	40 AMP	50 AMP

Note: Each trailer brake magnet is assumed to draw 3 amps of current and each brake lamp bulb is assumed to draw 2 amps.

**APPENDIX
 OEM TOW VEHICLE WIRING CONVERSIONS**

CHRYSLER (THROUGH 2002) RED W/BLACK TRACE WHITE W/TAN TRACE BLUE BLACK	CONTROLLER BLACK RED BLUE WHITE	FUNCTION +12 VOLT SUPPLY STOPLIGHT TRAILER BRAKES GROUND	CHRYSLER (NEW) WHITE W/ RED TRACE BLUE W/WHITE TRACE BLUE GREEN W/BLACK TRACE
FORD (THROUGH 2002) RED LIGHT GREEN BLUE WHITE BROWN	CONTROLLER BLACK RED BLUE WHITE NOT USED	FUNCTION +12 VOLT SUPPLY STOPLIGHT TRAILER BRAKES GROUND ILLUMINATION	FORD (NEW) PINK RED BLUE WHITE BROWN
FORD EXPEDITION RED RED/GREEN TRACE BLUE BLACK	CONTROLLER BLACK RED BLUE WHITE	FUNCTION +12 VOLT SUPPLY STOPLIGHT TRAILER BRAKES GROUND	
GENERAL MOTORS RED LIGHT BLUE DARK BLUE BLACK BROWN	CONTROLLER BLACK RED BLUE WHITE NOT USED	FUNCTION +12 VOLT SUPPLY STOPLIGHT TRAILER BRAKES GROUND ILLUMINATION	
2004 INFINITY RED RED/GREEN BROWN/WHITE BLACK RED/BLUE	CONTROLLER BLACK RED BLUE WHITE NOT USED	FUNCTION +12 VOLT SUPPLY STOPLIGHT TRAILER BRAKES GROUND ILLUMINATION	
RANGE ROVER REMOVE TAIL LIGHT AND CONNECT RED CONTROLLER WIRE TO BLACK/BLUE TRACE, NO LIGHT WITH MANUAL	CONTROLLER BLACK RED BLUE WHITE NOT USED	FUNCTION +12 VOLT SUPPLY STOPLIGHT TRAILER BRAKES GROUND ILLUMINATION	
2004 TITAN/ARMADA RED RED/GREEN BROWN/WHITE BLACK RED/BLUE	CONTROLLER BLACK RED BLUE WHITE NOT USED	FUNCTION +12 VOLT SUPPLY STOPLIGHT TRAILER BRAKES GROUND ILLUMINATION	
2004 TOYOTA TUNDRA BLACK-RED GREEN-WHITE RED BROWN	CONTROLLER BLACK RED BLUE WHITE	FUNCTION +12 VOLT SUPPLY STOPLIGHT TRAILER BRAKES GROUND	

Special Conditions

For tow vehicles equipped with factory trailer towing package:

- Refer to your vehicle owner’s manual or other information provided by the manufacturer in determining the correct connection points for the controller.
- See Appendix section for partial list of manufacturer wiring harness to controller conversions.

For vehicles **without** a trailer-towing package: refer to the wiring diagram in Figure 4.

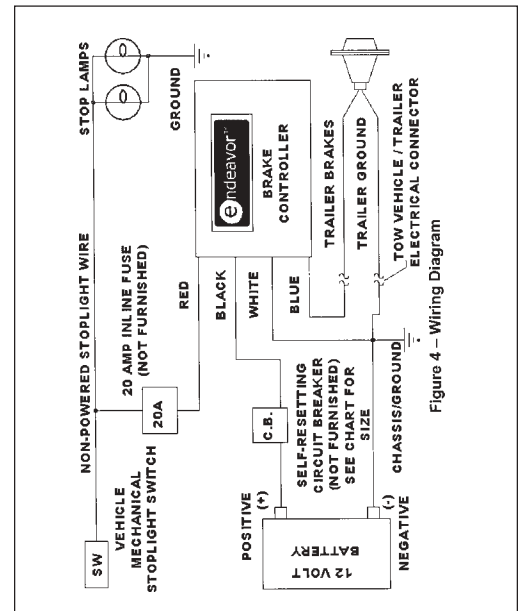

WARNING:

1989 - 1991 Ford Bronco, Econoline, F-Superduty, and F150-350 Series:

- The red stoplight wire **MUST** splice into the turn signal connector harness and **NOT** to the stoplight switch.
- Connecting to the stoplight switch will break the switch and result in no stoplights and no trailer braking.



WARNING:

All 1999 and later Ford vehicles without the trailer wiring package:

- The red controller wire must be connected to the light green wire of the brake stop light through a 20-amp inline fuse.
- Failure to install a 20-amp fuse can destroy the controller and void the manufacturing warranty.