

Bullseye Turning Supply

Apollo Fountain & Rollerball Kits

Supplies Required:

Drill Bits: 3/8, 29/64, 23/64, 5/16, 1/4"
Collet Chuck with 3/8" Collet
5 Min Epoxy
Apollo Mandrel Set
Live Center
Personal Protective Equipment
3/4" x 3/4" x ~6" Blank (Resin, Hybrid, or Stabilized Wood)
Recommended:
Calipers
Pen Jaws Or Collets To Drill On The Lathe



Getting Started

1. Make a mark on the blank at 2.5" from the edge. This side will be the cap, and should leave 3.5" for the body of the pen.
2. Cut the blank on your line with your tool of choice.

Drilling the Body Blank:

1. Hold your blank in a vice on the drill press or in pen jaws on the lathe.
2. Start with the 1/4" drill bit, and drill 2.8 inches into the blank. DO NOT DRILL ALL THE WAY THROUGH
3. Using the 5/16 drill bit, drill 1.825" into the blank.
4. Using the 23/64 drill bit, drill 1" into the blank.
5. Check the fit of your body assembly in the blank. Set aside.

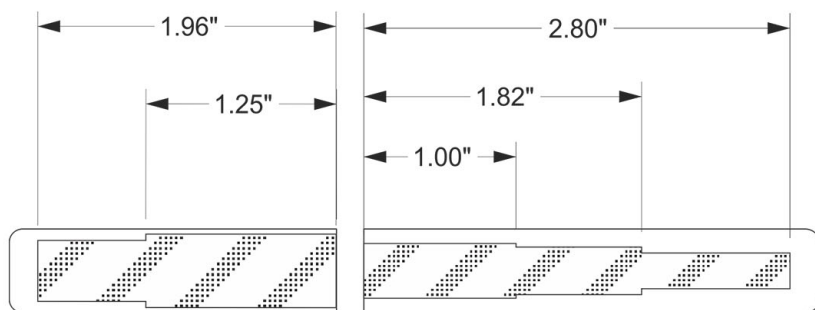

Drilling the Cap Blank:

1. Hold your blank in a vice on the drill press or in pen jaws on the lathe.
2. Start with the 3/8 drill bit, and drill 1.96" into the blank. DO NOT DRILL ALL THE WAY THROUGH
3. Using the 29/64" drill bit, drill 1.25" into the blank.
4. Check the fit of the cap sleeve in the cap blank. Set aside.

Gluing The Components:

1. Before gluing in your components, you may need to square the ends of your blanks. The easiest way to do this is on the lathe, but can also be done with some sandpaper. Make sure your ends are not concave, as this will cause a gap between the blanks allowing the hardware to show
2. Mix up some 5 min epoxy & lightly coat the outside of the body & cap sleeves. If you can, it helps to also lightly coat the inside of the cap blank with epoxy.
3. Press the body sleeve into the body blank. Wipe off any epoxy squeeze out.
4. Thread the cap insert onto the body hardware. Press the cap sleeve into the cap blank, and line up your two blanks. Wipe off any epoxy squeeze out

Turning:

1. Set up your collet chuck with 3/8" collet on your headstock. Insert the body mandrel into the collet and tighten snugly.
2. Once the epoxy is cured, thread the body of your pen onto the mandrel and put a small amount of pressure on the blank with the live center in the tailstock.
3. Turn the blank to the desired shape & part off the bit where the tailstock will leave a dimple.
4. Sand & polish. Repeat for the cap blank.

**Assemble the pen section onto the body blank &
enjoy the fruits of your labor!**

Bullseye Turning Supply

Apollo & Artemis Closed End Kits

Tips & Tricks

Mark your bits with a sharpie or some nail polish so that you don't have to measure the depth you need to drill every time

For rollerballs, drilling a little extra depth creates a squishy writing experience. Less depth will keep the refill very tight.

If you have a blank you want to use that isn't long enough, accent finials or a center band is a great way to gain some extra length on the blank

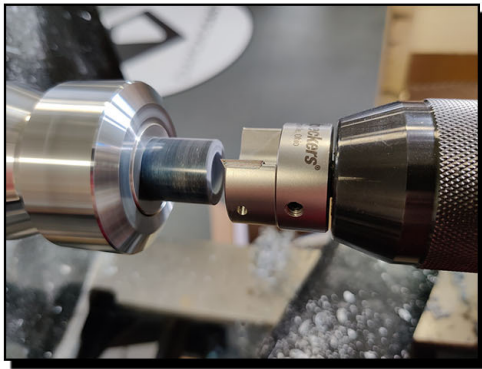

If you have a sharp barrel trimmer, using it in the tailstock to square the ends of the blanks before gluing works great.

Do a test drill before you drill your cap blank. Sloppier tailstocks should use a 7/16" drill bit. Tailstocks that run true are dead on with 29/64.

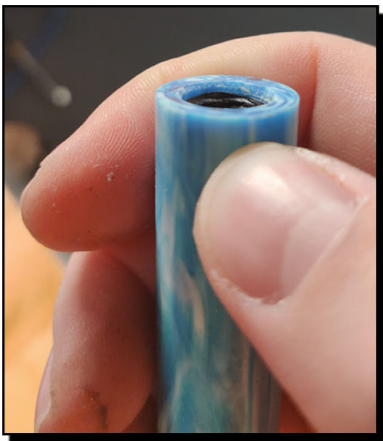

You do not want the cap insert to sit flush with the end of the blank. You should have a little bit of overhang that will cover the hardware that sits proud of the body blank. This is probably the easiest thing to mess up with these kits.

If you do mess this part up, it's very easy to part off the end of your cap blank down to the threaded insert and glue on an accent band. Then just turn the accent band down flush, apply your finish of choice, and no one will be the wiser



Get Creative & Have Fun! Don't forget to share photos of your finished pens with us!