

Features

- Edge-lit technology, no glare or dark spots, instant-on
- No existing recessed housing or junction box required
- Dimming: TRIAC 10% - 100%
- I.C. rated for direct contact with insulation
- Suitable for DAMP LOCATION
- Rated for a long life - over 50,000 hours
- Pre-Select 5 CCT - 2700K, 3000K, 3500K, 4000K, 5000K
- Energy Star Certified

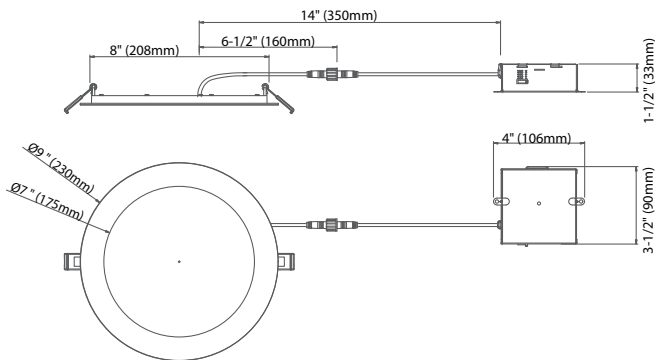

DIMENSIONS



INSTALLATION

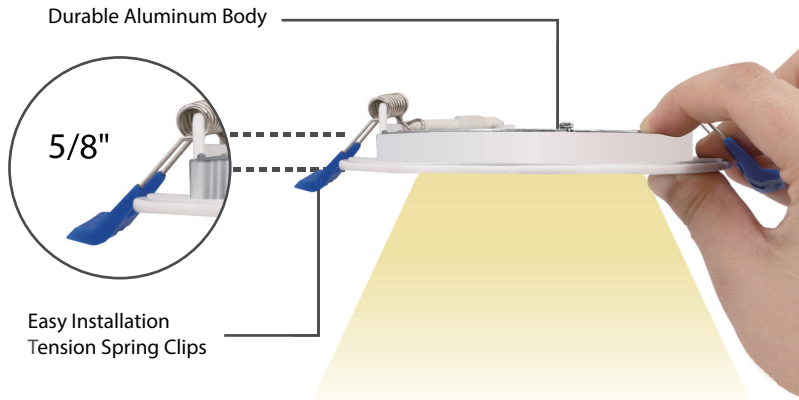
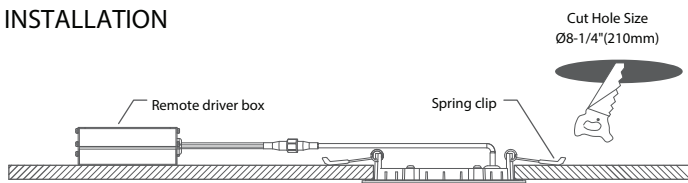

Low-profile, edge-lit design

SPECIFICATIONS	
Model	FDLED-8-18W-5CCT-120V
Watts	18W
Light Output(lm)	1125lm
Size	8in
Default Driver Input	AC120V,60HZ
Color Temperature(K)	Pre-Select 5CCT 2700K, 3000K, 3500K, 4000K, 5000K
CRI	80Ra
Dimming	Triac Dimming
Power Factor	>0.9
Approved Location	Damp Location
Air Tight	Yes
Operating Temp.	(-4°F~104°F) -20~40°C
Beam Angle	120°

PACKAGE	
Weight.(g)	611g
Qty/CTN (pcs)	18pcs/CTN
Box Dimension	685*570*220mm
Gross Weight	13.5kg/CTN

Accessories (Optional)

<h4>Extension Cables</h4> <p>10ft flexible connector, for use with Gimbal/ slim LED fixtures</p> <p>20ft flexible connector, for use with Gimbal/ slim LED fixtures</p>	<h4>Goof Ring</h4> <p>8" Goof Ring Inside Diameter - 8 1/4" (210mm) Outside Diameter - 10 1/2" (254mm) Thickness - 1mm for use with Gimbal/ slim LED fixtures</p>
---	---