

300W Triac dimmable 100-277VAC constant voltage LED driver + PWM signal output



■ Features:

- Output constant voltage
- Input voltage range 100-277VAC
- Built-in PFC function / PF>0.97
- Efficiency >88% / Dimming range: 0~100%
- Protections: short circuit/over voltage/over heat
- PWM output, does not change the color index
- IP20 design for indoor installations
- Cooling by free air convection / Flicker-free
- Work with leading edge and trailing edge TRIAC dimmers
- Strong compatibility, flicker-free dimming
- Suitable for LED lighting and moving sign applications
- Compliance to worldwide safety regulations for lightings.
- Compatible with Forward phase, Reverse phase, Triac, MLV, ELV Dimmers
- 7 years warranty

Specification





Class P Type HL CE IP20

Model		SMT-012-300VTH	SMT-024-300VTH
Output	DC Voltage	12V	24V
	Voltage Tolerance	±0.5V	
	Voltage Regulation	±0.5%	
	Voltage Tolerance	±0.5V	
	Load Regulation	±2%	±1%
	Rated current	25.0A	12.5A
	Rated power	300W	
Input	Voltage Range	100-277VAC	
	Frequency Range	47~63HZ	
	Power Factor (Typ.) @ fu	0.98@120VAC 0.97@277VAC	0.98@120VAC 0.97@277VAC
	THD (Typ.) @ full load	<20%	
	Inrush Current (Typ.)	20A, 50%, 1.4ms	
	Full Load Efficiency (Typ.)	>88%	>88%
	AC Current (Typ.)	3.4A@110VAC	
	Leakage current	<0.50mA	
Protection	Short Circuit	shut down o/p voltage, re-power on to recover after fault condition removed	
	Over load	≤120% constant current limiting, auto-recovery	
	Over temperature	100°C±10°C shut down o/p voltage, automatically recover after cooling.	
	Over Current	≤1.4*I out	
Environment	Working TEMP.	-40~+60°C	
	Working Humidity	20~90%RH, non-condensing	
	Storage TEM., Humidity	-40~+80°C, 10~95%RH	

	TEMP.coefficient	±0.03%/°C (0~50°C)
	Vibration	10~500Hz 2G 10min./1 cycle, period for 60min.each along X, Y,Z axes
Safety&EMC	Safety standards	UL8750
	Withstand voltage	I/P-O/P: 3.50KVAC
	Isolation resistance	I/P-O/P: 100MΩ/500VDC/25°C/70%RH
	EMC EMISSION	Compliance to EN55015,EN61000-3-2 (≥50%load) / FCC Part 15 B
	EMC IMMUNITY	EN61000-4-2,3,4,5,6,11 (Surge 4KV)
Others	Weight	1.9Kg
	Size	278*108*46mm (L*W*H)
	packaging	10PCS/CTN
Notes	1. All parameters NOT specially mentioned are measured at 110V & 277VAC input , rated load and 25°Cof ambient temperature. 2..Tolerance:includes set us tolerance,line regulation and load regulation.	

■Mechanical Specification

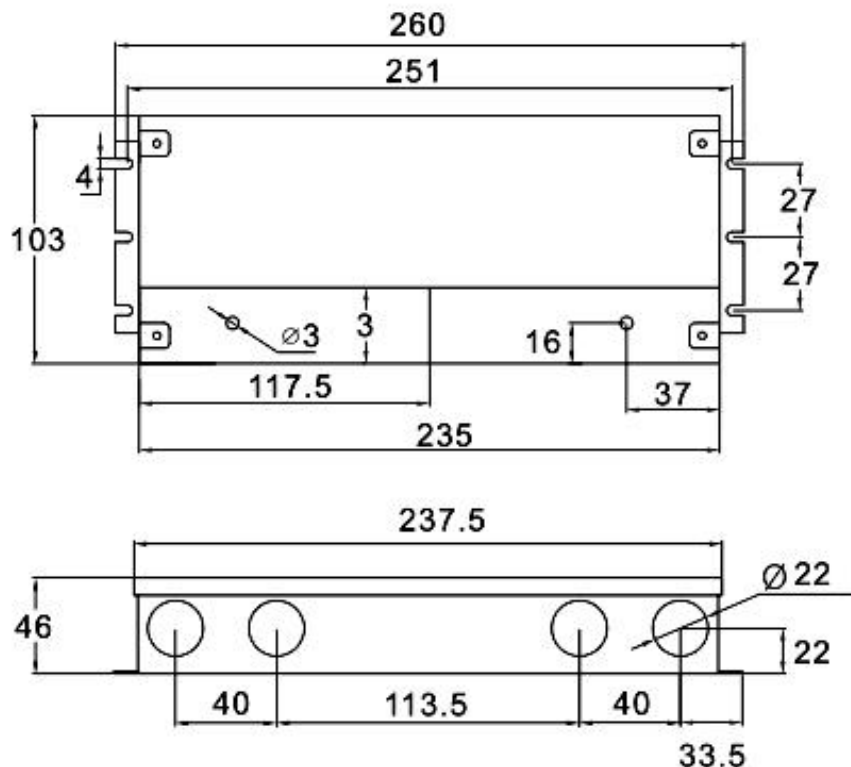

※Input:18AWG Black and White to be connected to AC L and N ,Green wire go ground,

※Output: Red is (DIM+) ,Black is (DIM-) UL 14AWG power cord

■Dimming Operation

※Output constant current level can be adjusted through input terminal of the AC phase line(L) by connection a triac dimmer.

※Compatible with Leading edge or trailing edge triac dimmers, but trailing edge dimmers work better..

※Please try to use dimmers with power at least 1.5 times as the output power of the driver.

■ Derating Curve

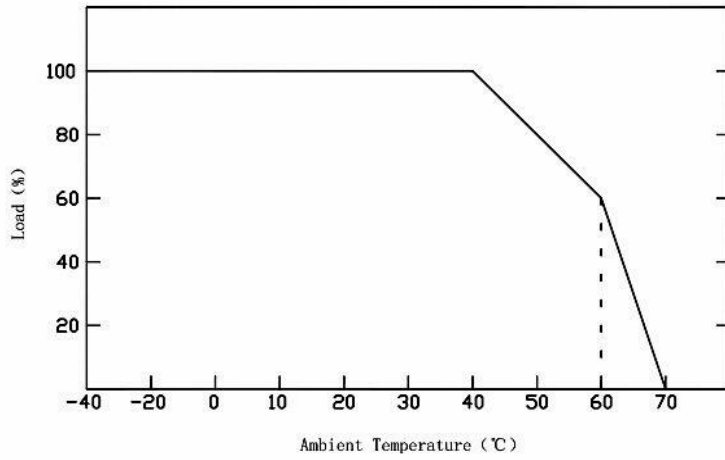

※To extend their life, please refer to the Derating Curve and derate according to the temperature.

■ Connecting Diagram

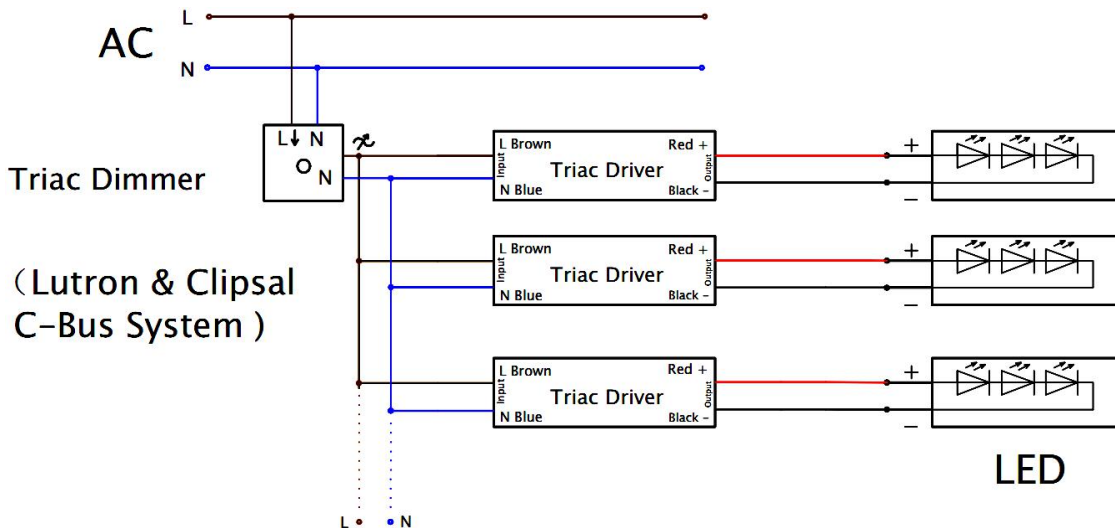
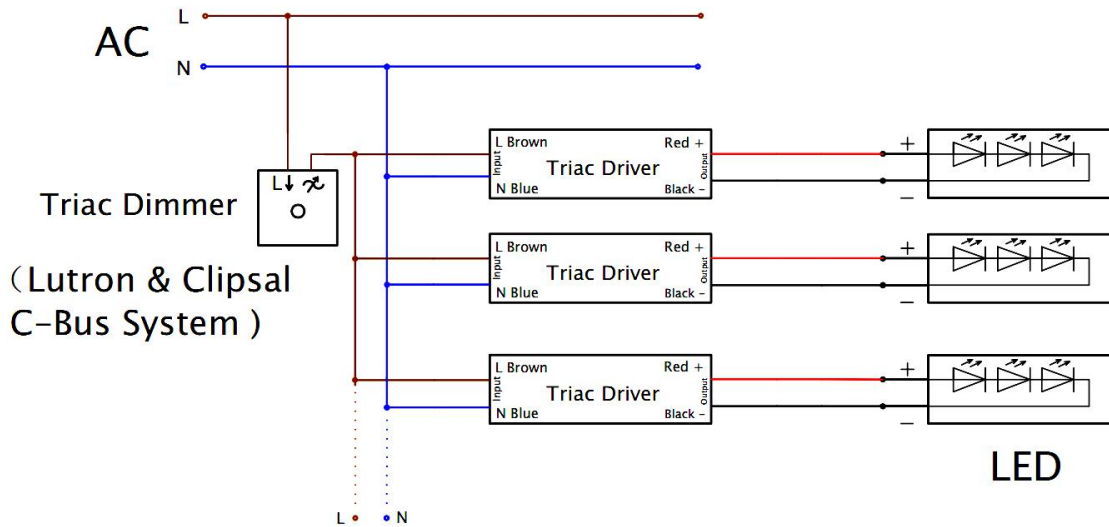

■ **Simple Connection Diagram:**

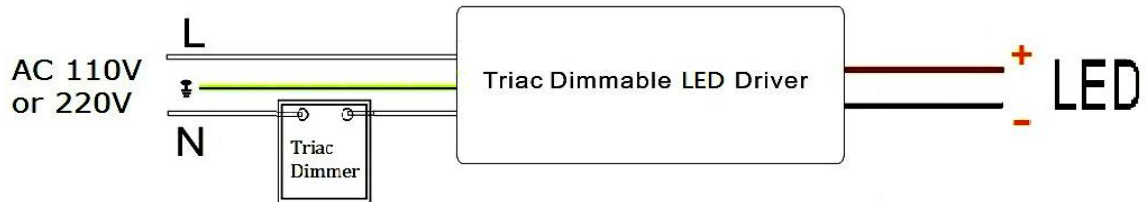

■ **Instruction:**

- ※ This driver should be installed by qualified and professional person;
- ※ Please make sure the driver is installed with adequate ventilation around it to allow for heat dissipation.
- ※ Ensure that wiring is correct before test in order to avoid light and power supply damage;