

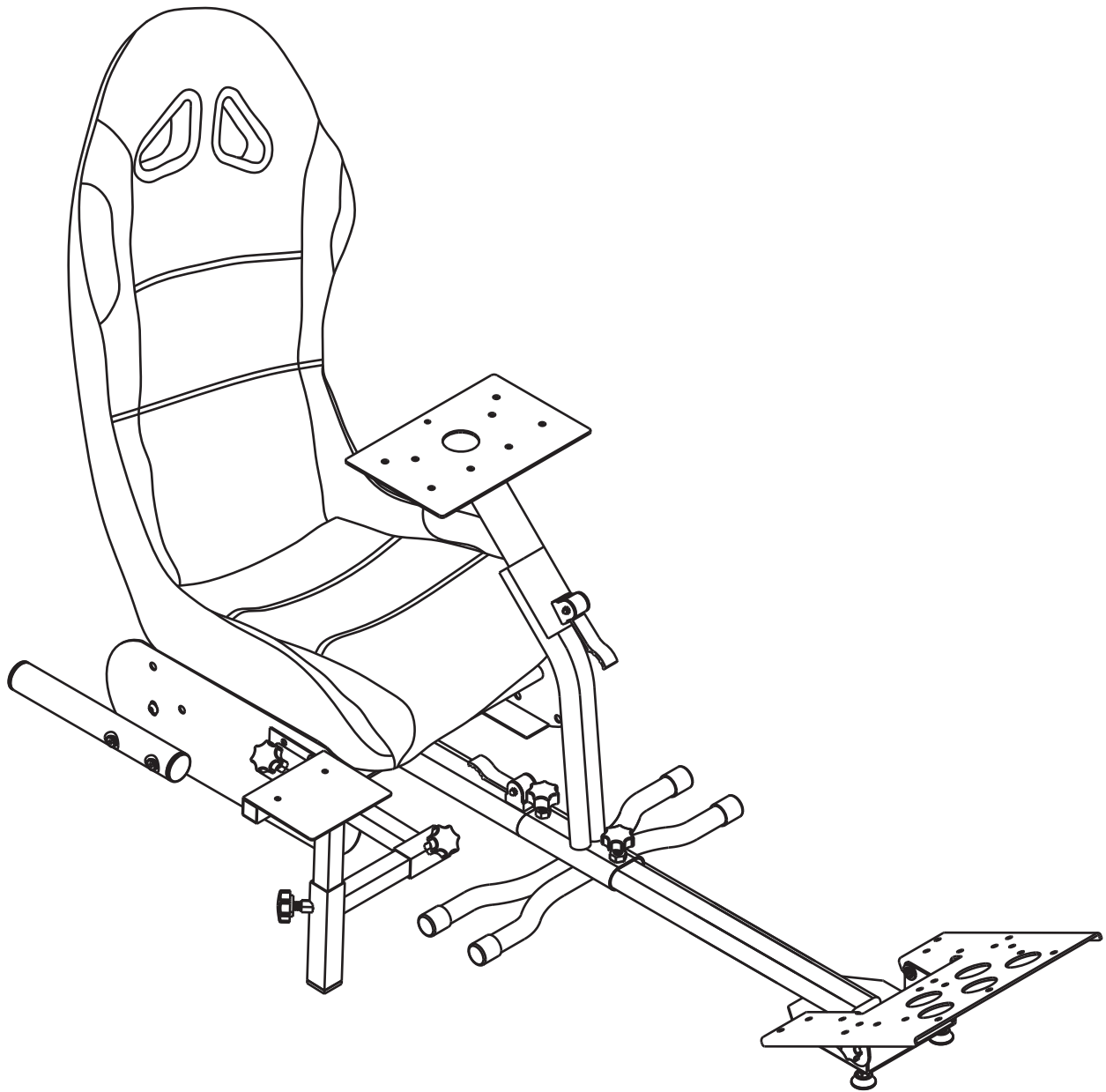

RACING CHAIR

Instruction Manual



Safety Warnings

GB

ATTENTION – Please note before assembling your Gaming Seat

- Check that you have all the parts and familiarise yourself with this installation guide.
- Make sure you have enough space to layout all the parts. Keep children and pets away from the work area, small parts could choke them if swallowed.
- Assembly is required. Installation must be carried out by qualified personnel only. Incorrect assembly can result in severe personal injury and property damage.
- Parts are heavy, take care when handling. For some steps 2 people are required for installation.
- Do not stand on the gaming seat, this could cause damage.
- Always use the gaming seat on a flat, stable surface to prevent injury.
- Only use this product when fully assembled.
- Keep this instruction manual for future reference.

Sikkerhetsadvarsler

NO

ADVARSEL – Ta hensyn til dette når du monterer spillsetet

- Kontroller at du har alle delene og gjør deg kjent med denne hurtigstartguiden.
- Påse at du har nok plass til å legge ut alle delene. Hold barn og kjæledyr borte fra arbeidsområdet, fordi små deler kan forårsake kvelning hvis de svelges.
- Montasje er påkrevet. Installasjonen må kun utføres av kvalifisert personale. Feilmontasje kan medføre alvorlig personskade og skade på eiendom.
- Delene er tunge – utvis varsomhet under håndtering. Det kreves 2 personer under enkelte installasjonstrinn.
- Ikke stå på spillsetet, da dette kan forårsake skade.
- Bruk alltid spillsetet på en flat, stabil overflate for å unngå skade.
- Bruk dette produktet kun etter at det er ferdigmontert.
- Ta vare på denne bruksanvisningen for fremtidig referanse.

Säkerhetsföreskrifter

SE

OBS! – Viktigt att tänka på innan du monterar din gamingstol

- Kontrollera att du har alla delarna och bekanta dig med installationsguiden.
- Kontrollera att du har tillräckligt med utrymme för att lägga ut alla delarna. Håll barn och djur borta från arbetsområdet. Små delar kan kväva dem om de sväljs.
- Montering krävs. Installationen måste utföras av kvalificerad personal. Felaktig montering kan resultera i allvarliga personskador och skador på egendom.
- Delar är tunga, var försiktig vid hanteringen. För vissa steg krävs två personer för installationen.
- Stå inte i gamingstolen, detta kan orsaka skada.
- Använd alltid gamingstolen på en platt och stabil yta för att förhindra skada.
- Använd bara produkten när den är färdigmonterad.
- Spara denna bruksanvisning för framtida referens.

HUOMIO – Huomaa ennen pelituolin kokoamista

- Tarkista, että kaikki osat ovat käsillä ja tutustu tähän asennusoppaaseen.
- Varmista, että tilaa on riittävästi kaikkien osien esillepanoon. Pidä lapset ja lemmikkieläimet poissa työskentelyalueelta. Pienet osat voivat nieltynä aiheuttaa tukehtumisen.
- Kokoonpano vaaditaan. Asennuksen saa suorittaa vain pätevä henkilö. Virheellinen kokoonpano voi johtaa vakaviin henkilö- ja omaisuusvahinkoihin.
- Osat ovat painavia. Ole varovainen käsitellessäsi niitä. Joihinkin asennusvaiheisiin tarvitaan kaksi henkilöä.
- Älä seiso pelituolilla, se voi aiheuttaa vahinkoa.
- Käytä pelituolia vammaan välttämiseksi aina tasaisella, vakaalla pinnalla.
- Käytä tätä tuotetta vain, kun se on koottu kokonaan.
- Säilytä tämä käyttöopas tulevaa tarvetta varten.

Sikkerhedsforanstaltninger

VIGTIGT - Bemærk venligst følgende, inden dit gamingsæde samles

- Kontroller at du har alle delene, og gør dig bekendt med brugervejledningen.
- Sørg for at du har nok plads til at ligge alle delene ud. Hold børn og dyr væk fra arbejdsområdet. De små dele udgør en risiko for kvælning, hvis de sluges.
- Samling er påkrævet. Montering skal udføres af autoriserede serviceteknikere. Forkert samling kan resultere i alvorlig personskade og ejendomsskade.
- Delene er tunge. Vær venligst forsigtig når du håndterer dem. I nogle af trinene er det nødvendigt at 2 personer udfører dem.
- Undgå, at stå på dit gamingsæde, da dette kan beskadige det.
- Gamingsædet skal altid bruges på en flad og stabil overflade for at forhindre skade.
- Brug kun dette produkt, når det er samlet helt.
- Gem venligst denne brugervejledning til senere brug.

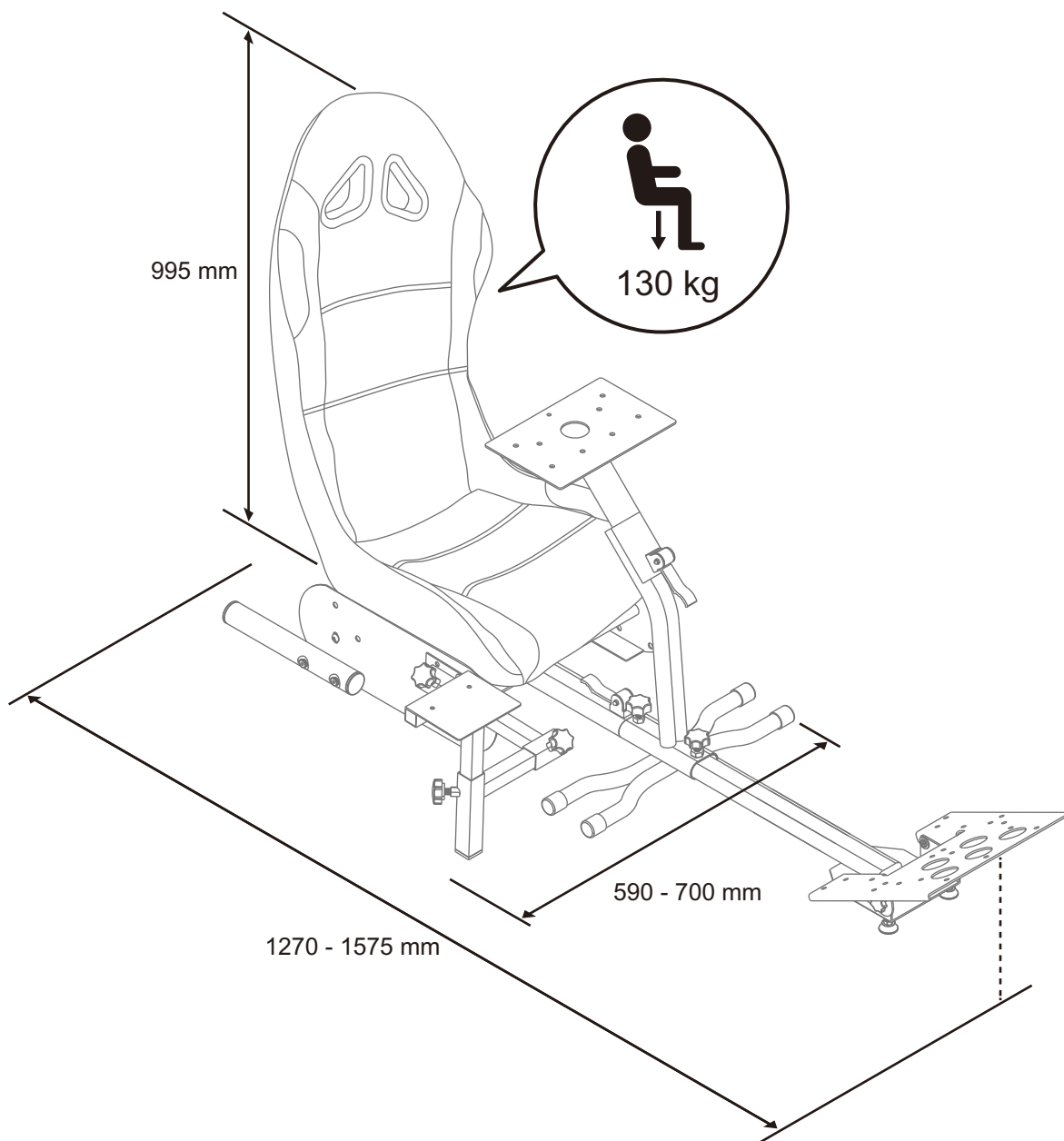

2 people are required to lift the unit during assembly.

Det kreves to personer for å løfte denne enheten under montering.

Det krävs 2 personer för att lyfta enheten under monteringen.

Laitteen nostamiseen kokoonpanovaiheessa tarvitaan kaksi henkilöä.

Det kræver 2 personer, at løfte enheden under samlingen.

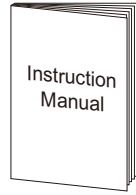
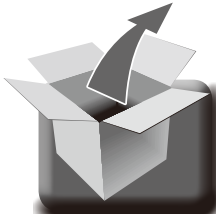

1 x 2

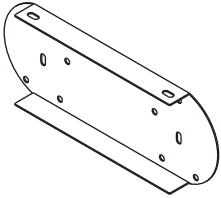

2 x 2

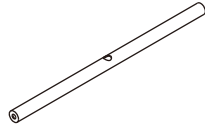

3 x 2

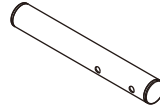

4 x 1

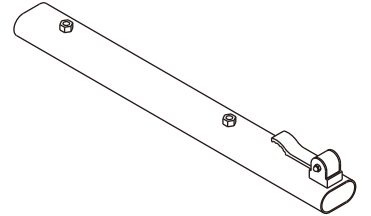

5 x 1

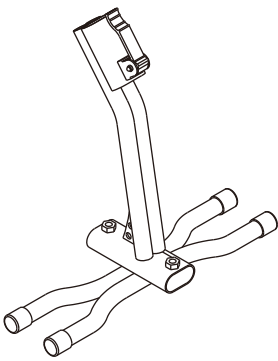

6 x 1

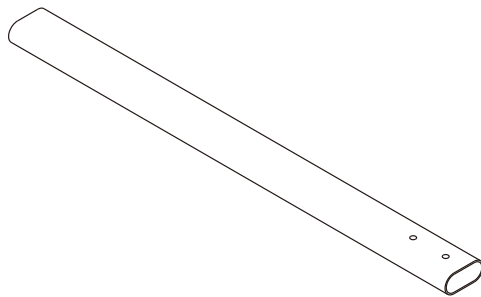

7 x 1

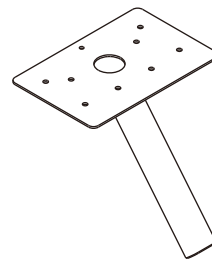

8 x 1

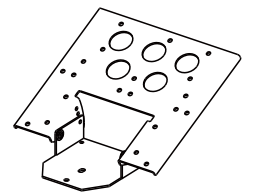

9 x 1

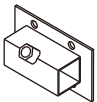

10 x 1

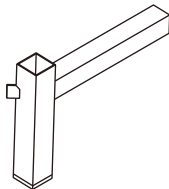

11 x 1

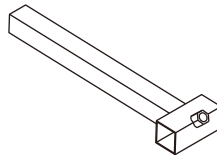

12 x 1

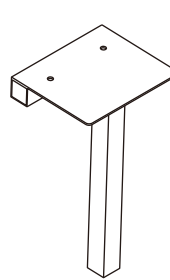

13 x 1

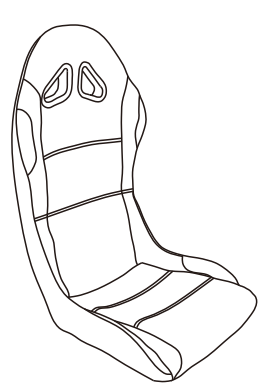

A x 12



B x 4



C x 6



D x 6



E x 2

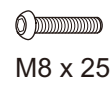

F x 5



G x 2



H x 2



I x 1



J x 1



K x 1

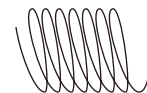

1

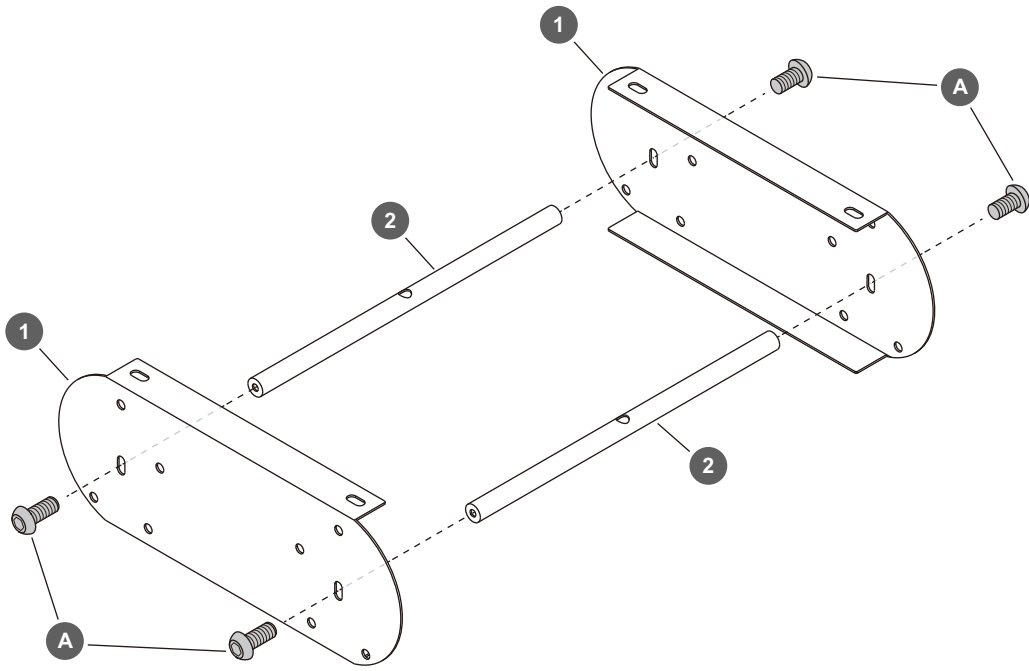

2

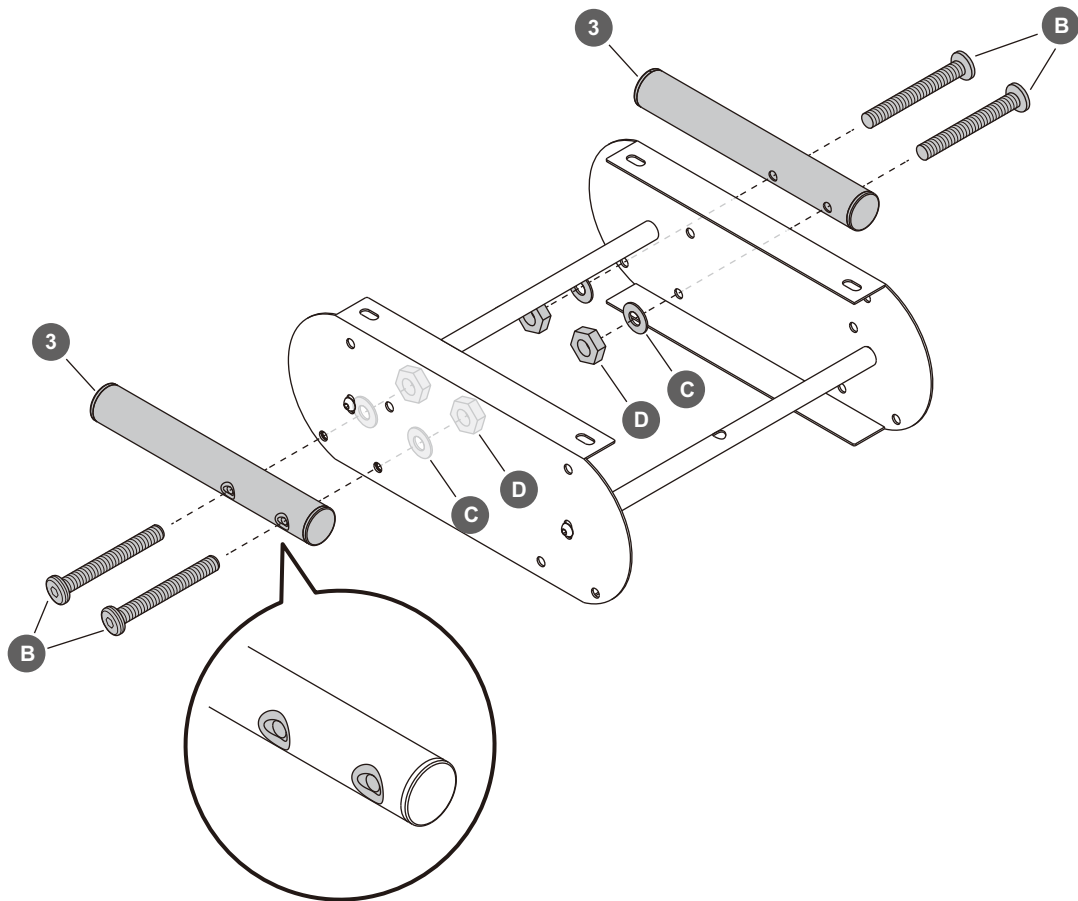

3

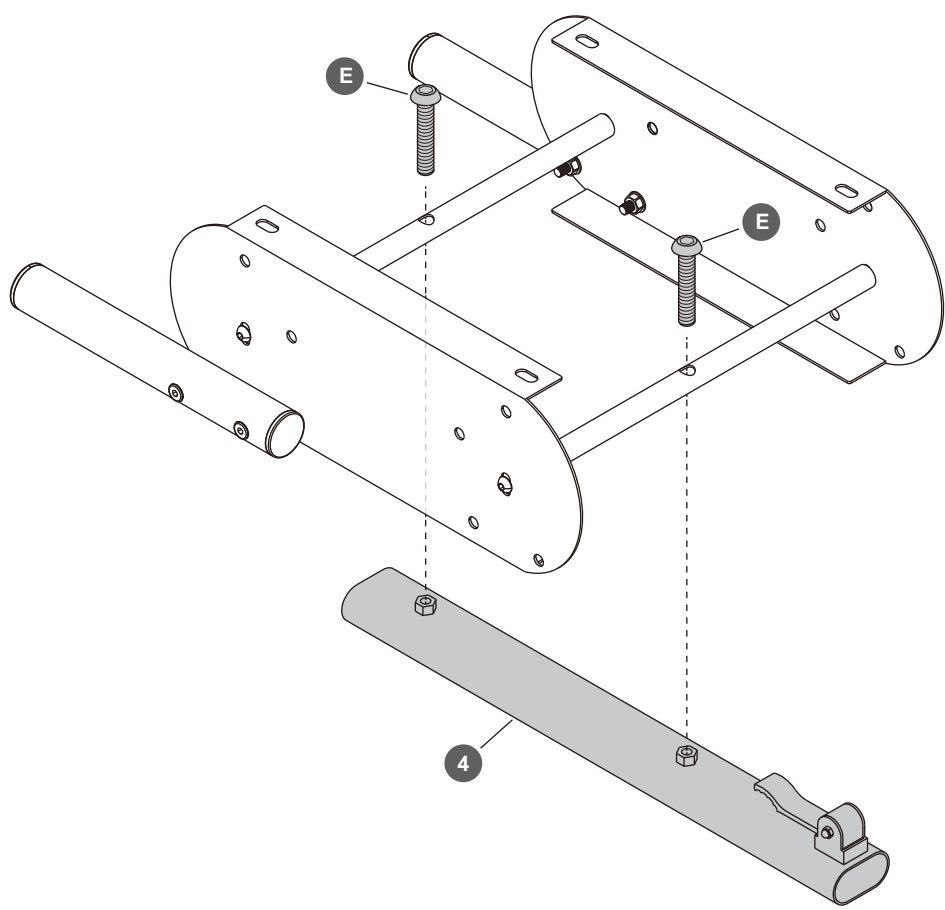

4

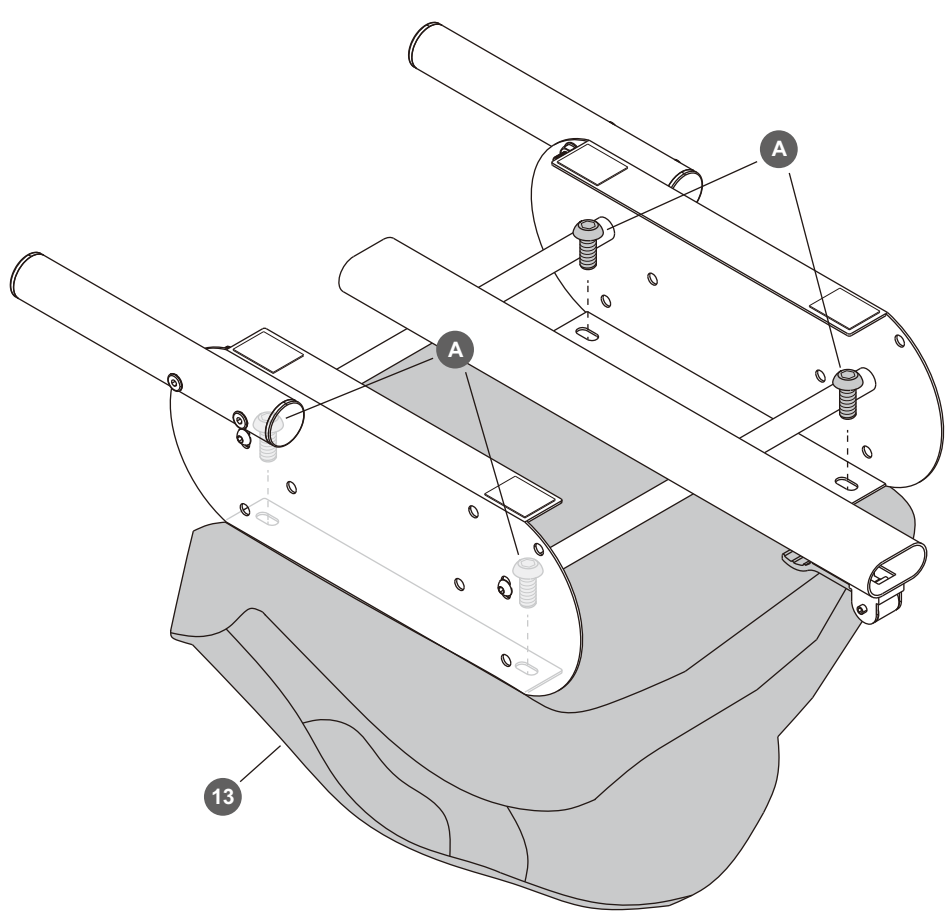

5

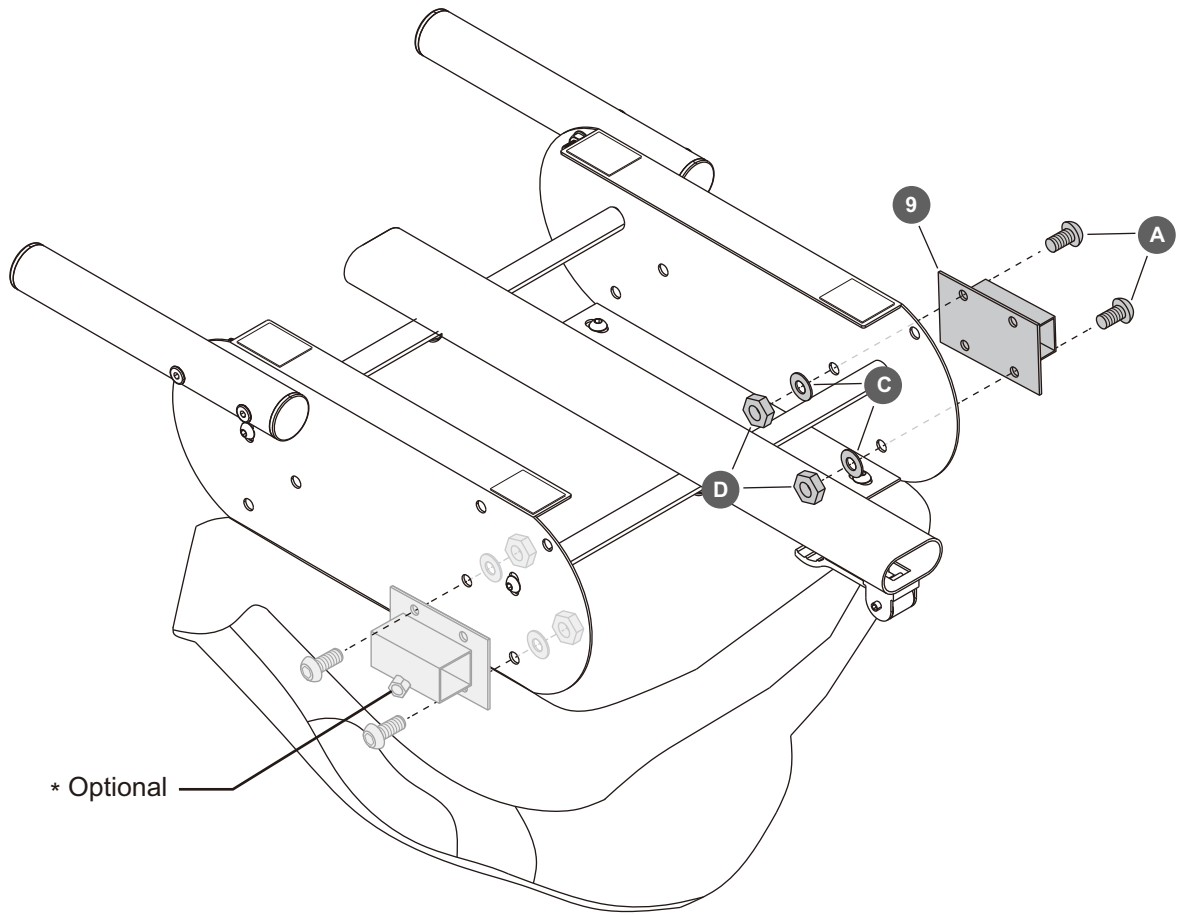

6

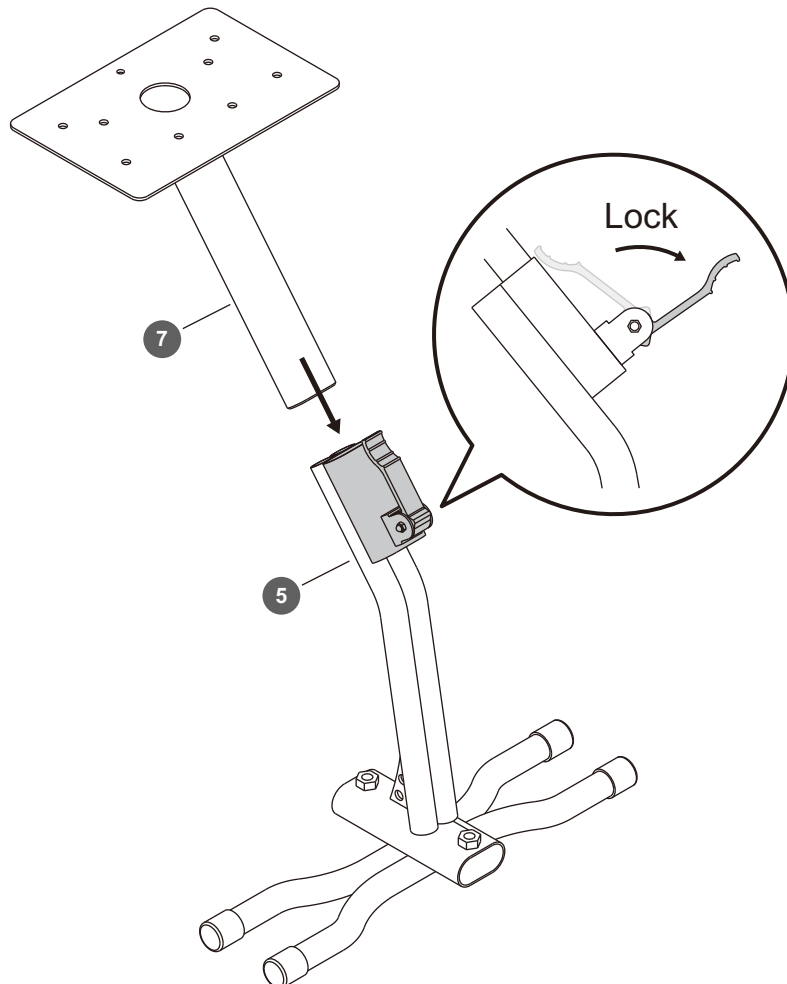

7

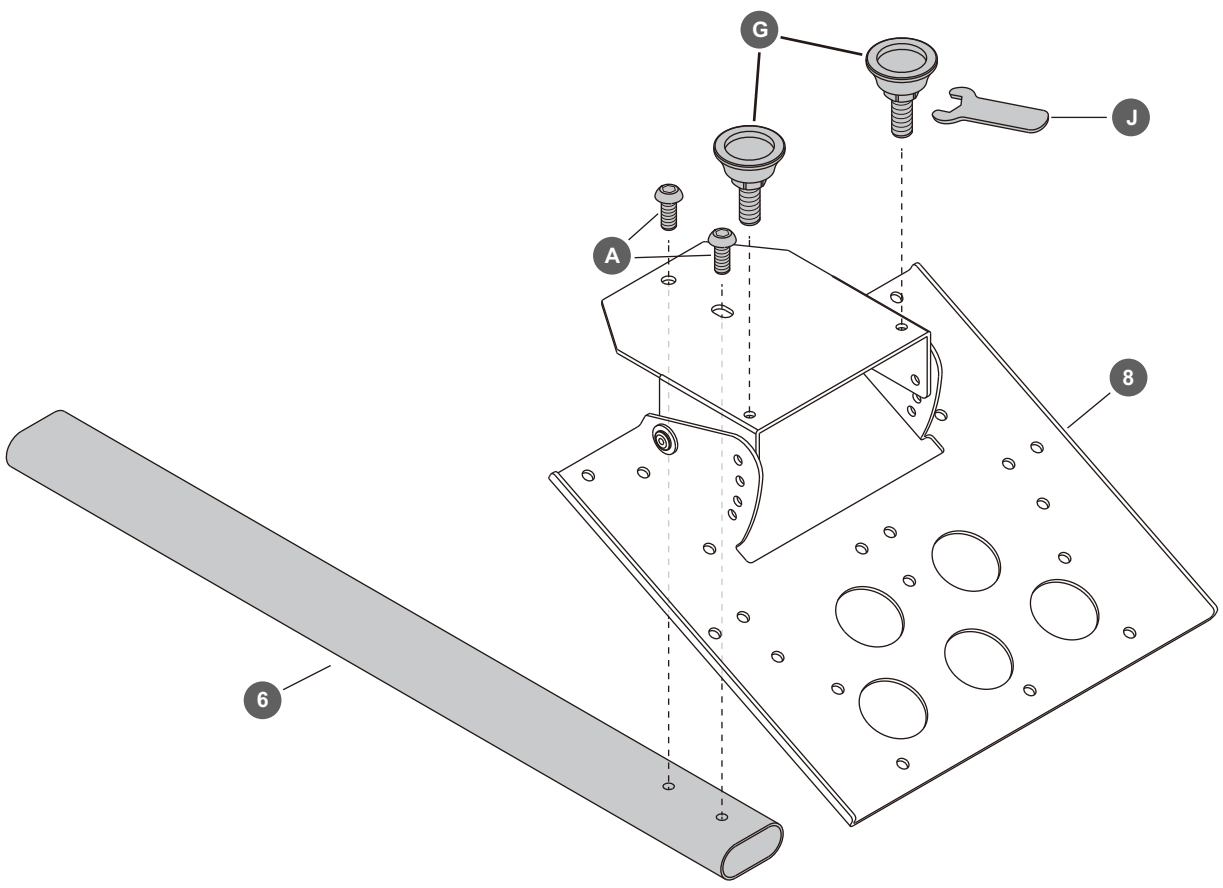

8

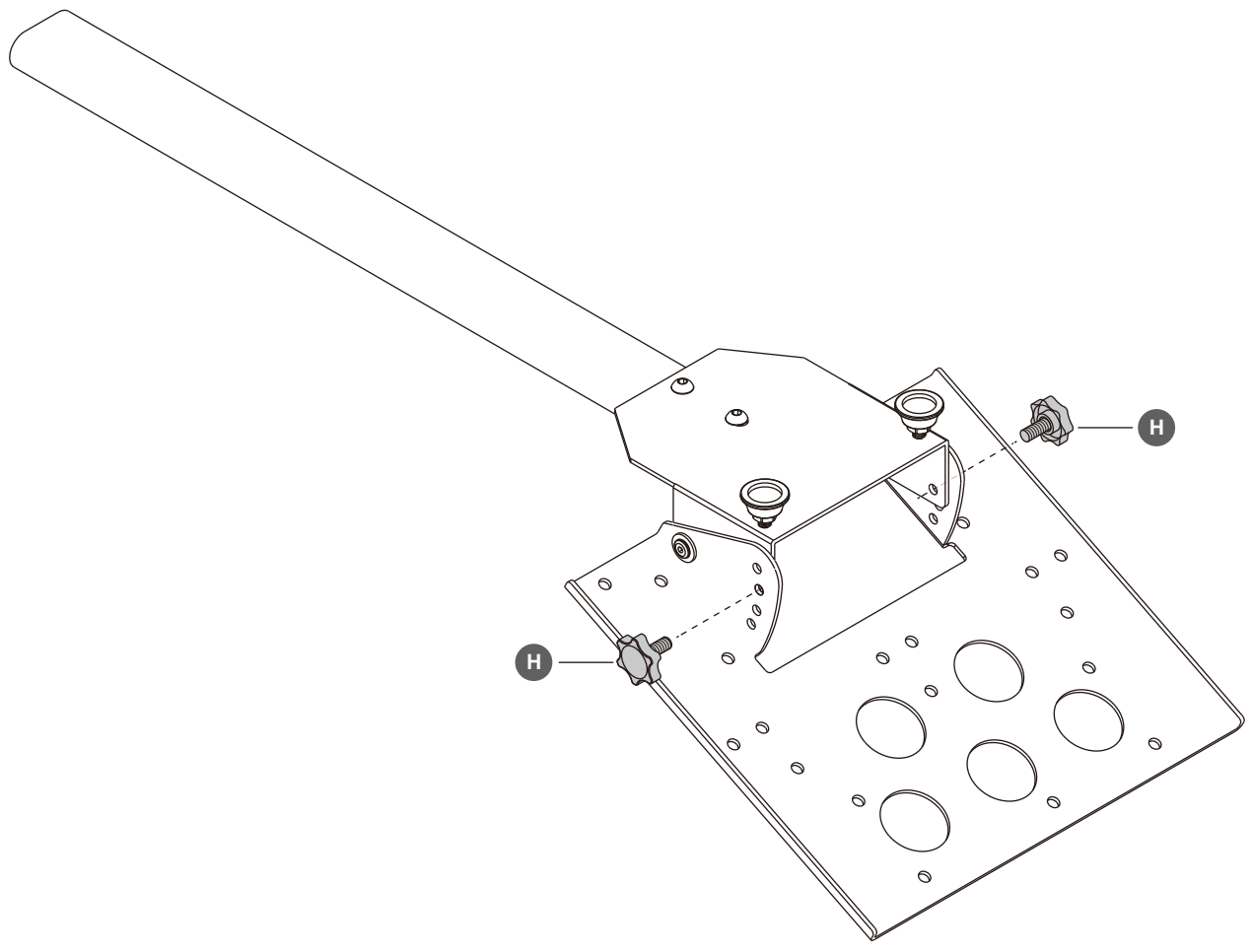

9

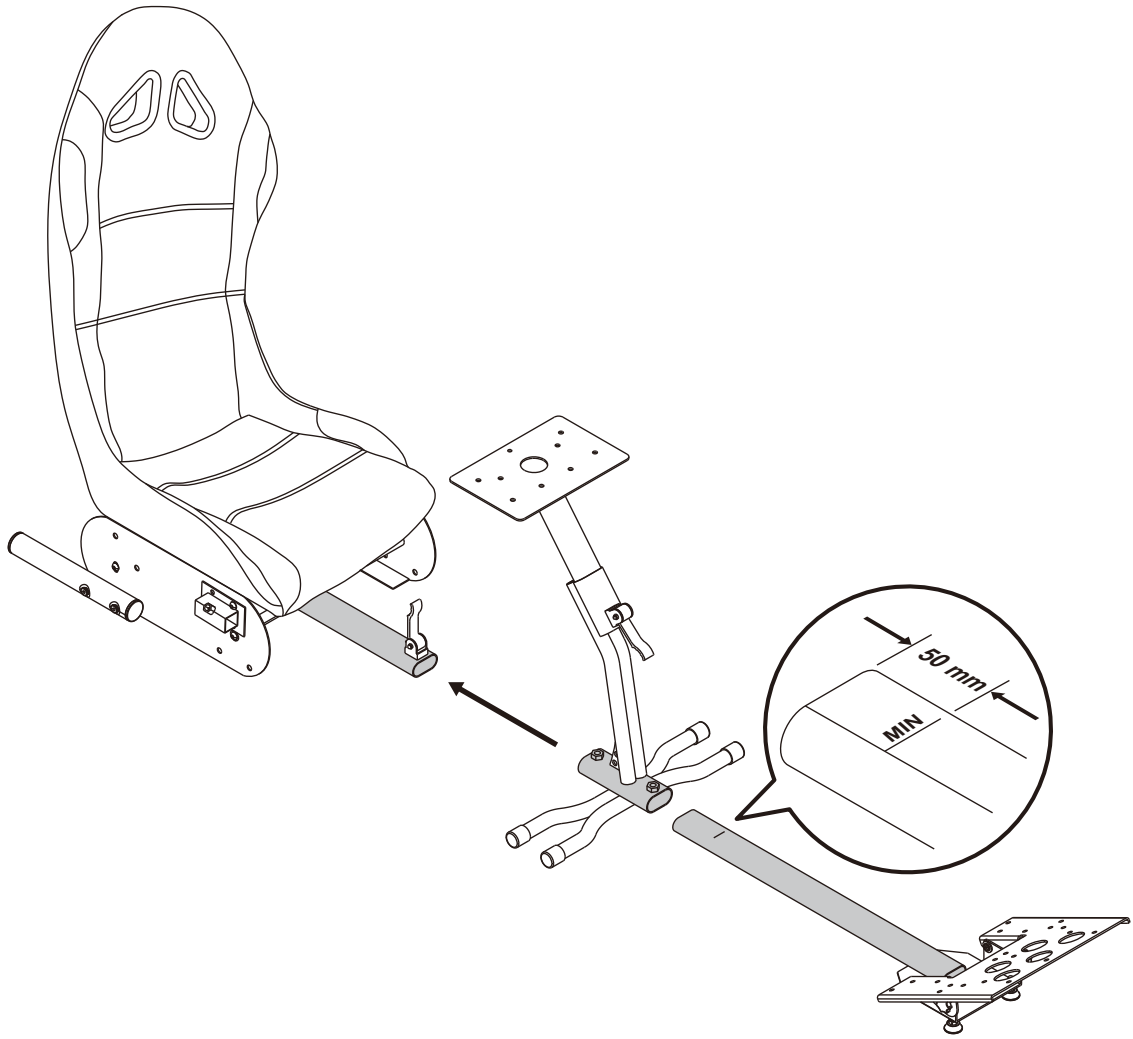

10

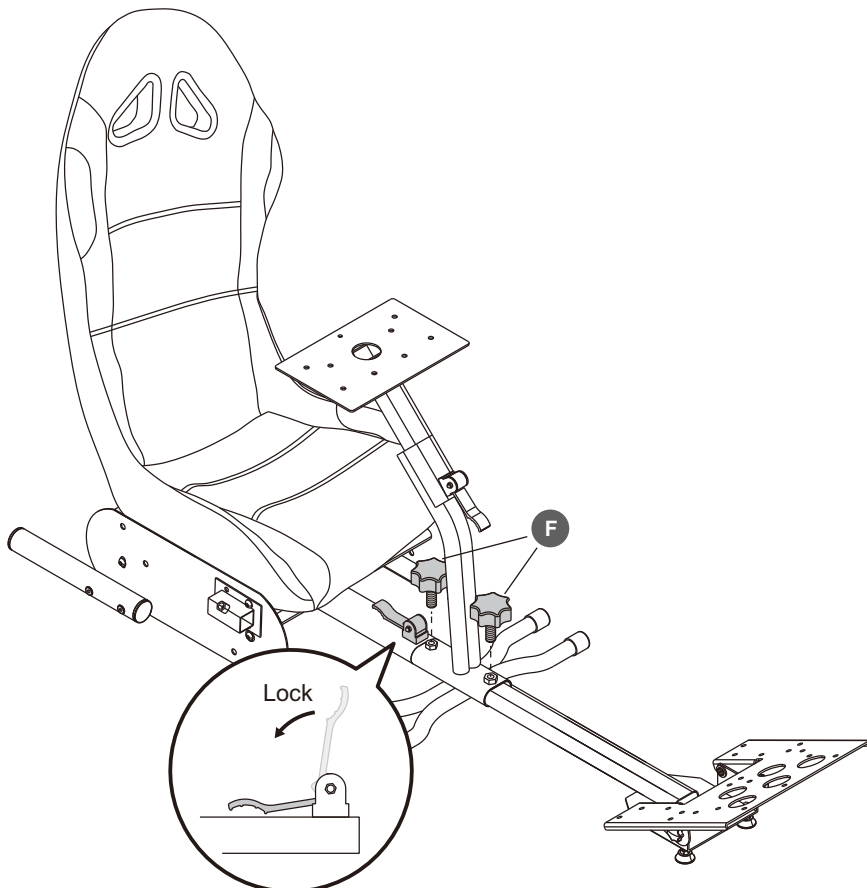

11

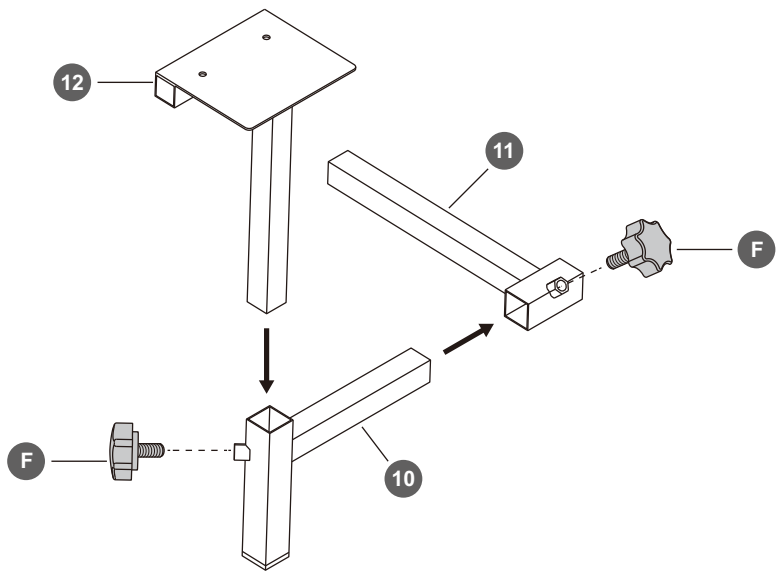

12

