

# WALL MOUNT SPEAKERS

**BS-634    BS-1034**  
**BS-634T    BS-1034S**

Thank you for purchasing TOA's Wall Mount Speaker. Please carefully follow the instructions in this manual to ensure long, trouble-free use of your equipment.

## 1. SAFETY PRECAUTIONS

- Before installation or use, be sure to carefully read all the instructions in this section for correct and safe operation.
- Be sure to follow all the precautionary instructions in this section, which contain important warnings and/or cautions regarding safety.
- After reading, keep this manual handy for future reference.

### **WARNING**

Indicates a potentially hazardous situation which, if mishandled, could result in death or serious personal injury.

- As a force of approx. 18 kg (39.68 lb) is applied to the speaker receptacle at the time of speaker installation, attach it in a location durable enough to withstand the force. Doing otherwise may result in the unit falling down, causing personal injury.
- Do not use other methods than specified to mount the bracket. Extreme force is applied to the unit and the unit could fall off, possibly resulting in personal injuries.
- Use nuts and bolts that are appropriate for the wall's structure and composition. Failure to do so may cause the speaker to fall, resulting in material damage and possible personal injury.
- Ensure that all screws are securely tightened. If they are loose after installation, the unit could fall down, possibly resulting in personal injury.

### **CAUTION**

Indicates a potentially hazardous situation which, if mishandled, could result in moderate or minor personal injury, and/or property damage.

- To avoid electric shocks, be sure to switch off the amplifier's power when connecting speakers.
- Do not operate the unit for an extended period of time with the sound distorting. This is an indication of a malfunction, which in turn can cause heat to generate and result in a fire.
- Do not stand or sit on, nor hang down from the unit as this may cause it to fall down or drop, resulting in personal injury and/or property damage.

## 2. FEATURES

- Thin type wall mount speaker with 5" cone speaker unit
- Two-way speaker system employing a balanced dome tweeter and elliptical horn for high-frequency sound reproduction in combination with a 5" cone speaker unit ensures high-quality sound. (BS-1034 and BS-1034S)
- The speaker's smoothly curved surface in combination with its straight lines permits it to blend in with virtually all modern buildings.
- Equipped with a speaker receptacle, providing speaker cable connection and installation ease.
- Equipped with a lock mechanism, preventing the speaker from being detached easily after installation.
- In-wall wiring, exposed wiring, or bridge wiring available for speaker cable connection
- The input power (impedance) can be easily changed by the rear-mounted rotary switch. (BS-1034 and BS-1034S)
- The BS-634T has a built-in attenuator and can be connected to a 3-wire and 2-wire systems.

## 3. WIRING DIAGRAMS

### 3.1. BS-634

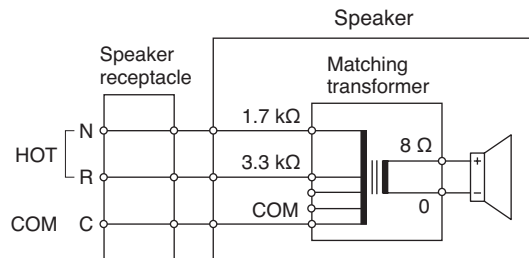

### 3.2. BS-634T

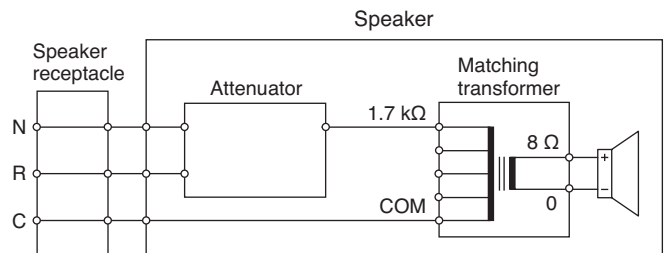

### 3.3. BS-1034 and BS-1034S

#### Note

Never make 500 Ω connection in a 100 V line system.

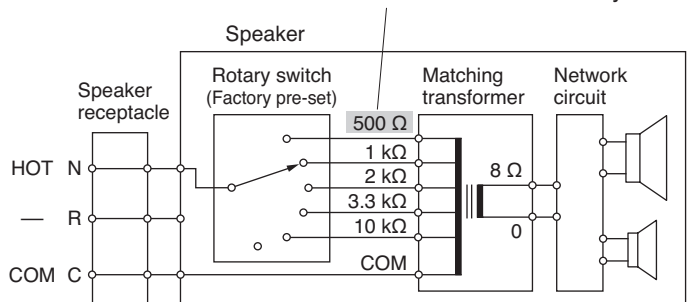

## 4. CONNECTION

Connect the speaker cable to the supplied speaker receptacle. Connections differ depending on the speaker to be installed. Read the descriptions of the corresponding model.

### 4.1. BS-634 connection

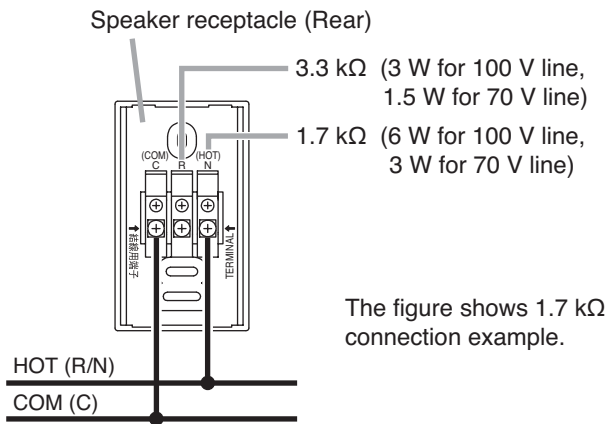

The input power is set to 6 W (100 V line) by connecting the Hot line to the N-terminal, and 3 W (100 V line) by connecting it to the R-terminal.

	N-terminal	R-terminal
Impedance	1.7 kΩ	3.3 kΩ
100 V line	6 W	3 W
70 V line	3 W	1.5 W

### 4.2. BS-634T connection

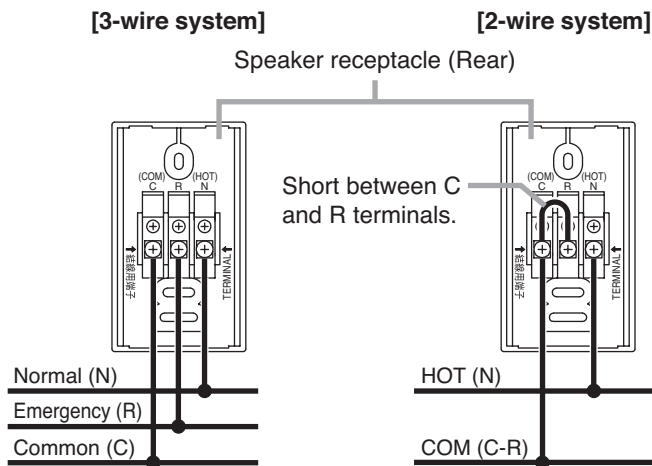

### 4.3. BS-1034 and BS-1034S connections

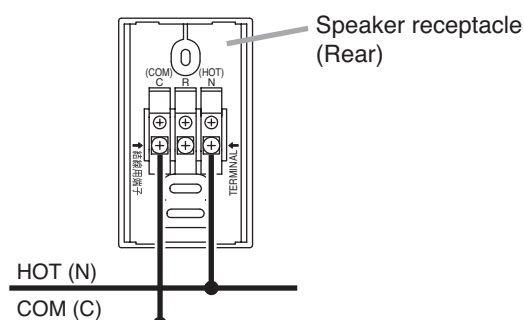

## 5. INSTALLATION

**Step 1.** Attach the speaker receptacle to a wall.

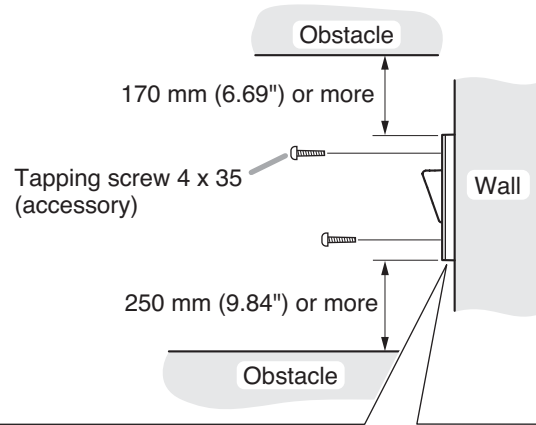

### Notes on speaker receptacle mounting

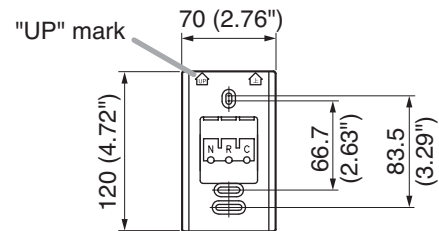

- If the supplied tapping screws are not appropriate for the construction of wall, separately prepare the appropriate screws.
- Install the speaker receptacle referring to its "UP" mark.
- Position the receptacle at the specified distance away from any object above and below it for vertical speaker mounting. Keep the same distance to the right and left of the receptacle (positioned sideways) for horizontal speaker mounting.

### [Notes on horizontal speaker mounting]

- Even if the speaker receptacle is attached horizontally, the speaker may be tilted due to its weight unbalance when attached to the receptacle.
- Be sure to attach the speaker so that its volume control is positioned downward. (BS-634T only)
- When changing the logo direction, peel off the logo carefully as it is affixed using double-faced tape. Then, re-affix it in the right orientation.

### [Exposed wiring]

Notch the top of the speaker receptacle using long-nose pliers, then make connections.

Split the speaker cable into 2 branches just before it enters the speaker receptacle so that it can be routed in the cable-guide groove on the rear side of the speaker.

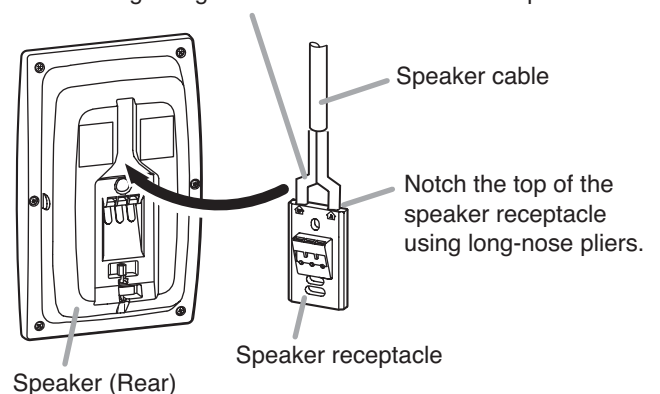

**Step 2.** Change the input power (impedance) as needed. (BS-1034 and BS-1034S only)

The input power (impedance) is factory-preset to 10 W (1 k $\Omega$ ) for 100 V line.

When changing this setting, use a standard screwdriver to turn the rotary switch on the speaker's rear panel to the desired position.

**Note**

Be sure to follow the instructions below. Failure to do so may cause damage to the speaker as excessive input power is applied to it.

- Switch off the amplifier's power when changing the input power.
- Never make 500  $\Omega$  connection in a 100V line system, as excessive input power is applied to the speaker, possibly resulting in damage.

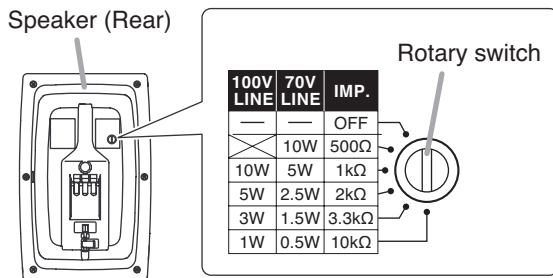

Impedance	500 $\Omega$	1 k $\Omega$	2 k $\Omega$	3.3 k $\Omega$	10 k $\Omega$
100 V line	Never use this.	10 W	5 W	3 W	1 W
70 V line	10 W	5 W	2.5 W	1.5 W	0.5 W

**Step 3.** Hold and slide the speaker to insert its speaker plug into the speaker receptacle.

**Note**

In this case, force the speaker onto the speaker receptacle holding the speaker outer frame.

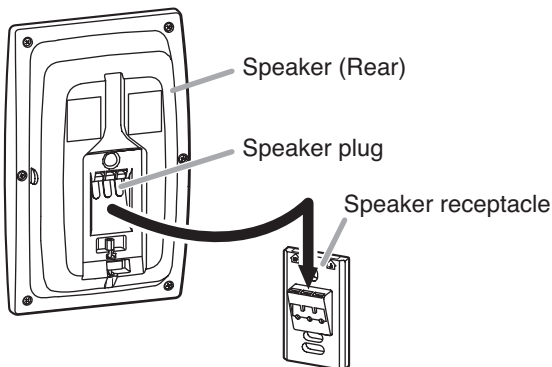

**Step 4.** Secure the speaker.

Turning the lock screw approximately about 3 counterclockwise turns using a Phillips screwdriver causes the flap to rise up and stay upright.

**Caution**

After speaker installation, be sure to make a visual check that the flap rises to lock the speaker completely.

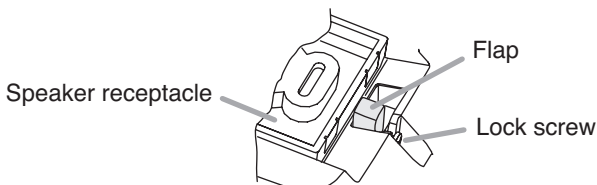

**About lock mechanism**

The lock mechanism is as shown below.

It prevents the speaker from being detached easily after installation.

**Note**

Be sure to follow the instructions below. Failure to do so may cause damage to the lock mechanism.

- Do not use an electric screwdriver when turning the lock screw.
- Do not turn the lock screw more than the specified turns.

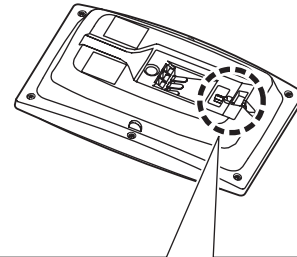

**[When fixing the speaker]**

Turning the lock screw counterclockwise causes the flap to rise up and move until it stops against the other side of the recess.

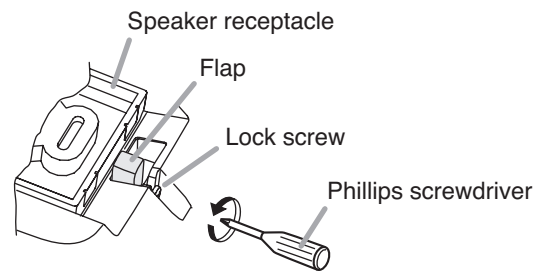

**[When detaching the speaker]**

Turning the lock screw clockwise causes the flap to lie down and move until it stops against the front side of the recess. (Factory preset position)

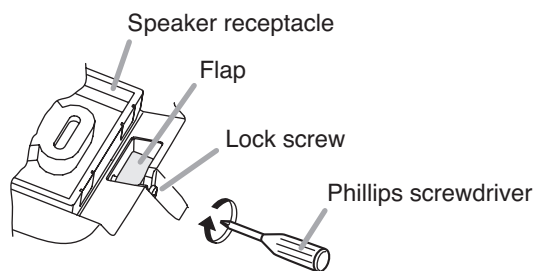

**6. DETACHING THE SPEAKER**

**Step 1.** Turn the lock screw approximately 3 clockwise turns.

The flap lies down and stays laid. (Refer to "About lock mechanism.")

**Step 2.** Hold and slide the speaker to unplug it from the speaker receptacle.

## 7. VOLUME ADJUSTMENT (BS-634T ONLY)

Adjust the sound volume by rotating the rotary switch\* on the speaker's side panel using a standard screwdriver.

\* It is positioned rightward as viewed from the front for vertical speaker installation, or downward for horizontal speaker installation.

Switch position	3	2	1	OFF
Sound volume	High (0 dB)	Middle (-6 dB)	Low (-12 dB)	Off

**Note:** Switch position is factory-preset to "3."

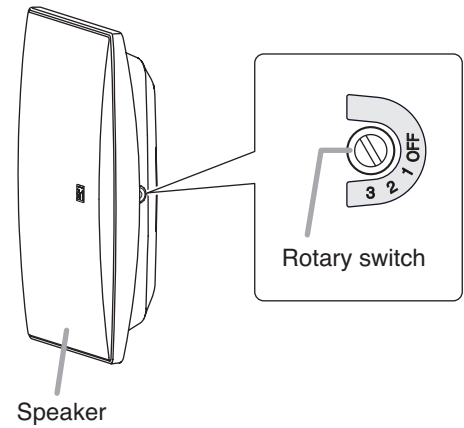

## 8. SPECIFICATIONS

### 8.1. BS-634 and BS-634T

Model No.	BS-634	BS-634T
Rated Input	6 W	
Rated Impedance	100 V line: 1.7 k $\Omega$ (6 W), 3.3 k $\Omega$ (3 W) 70 V line: 1.7 k $\Omega$ (3 W), 3.3 k $\Omega$ (1.5 W)	100 V line: 1.7 k $\Omega$ (6 W) 70 V line: 1.7 k $\Omega$ (3 W)
Sensitivity	90 dB (1 W, 1 m)	
Frequency Response	120 – 18,000 Hz	
Speaker Component	12 cm (5") cone-type	
Input Connector	M4 screw terminal, distance between barriers: 11 mm (0.43")	
Attenuation	—	OFF, 1 (-12 dB), 2 (-6 dB), 3 (0 dB)
Finish	Enclosure	HIPS resin (fire resistant grade UL94 V-0 or its equivalent), off white (RAL 9010 or equivalent color)
	Net	Surface-treated steel plate, off white (RAL 9010 or equivalent color), paint
Dimensions	210 (w) x 330 (h) x 80 (d) mm (8.27" x 12.99" x 3.15")	
Weight	1.3 kg (2.87 lb)	
Accessories	Speaker receptacle ..... 1, Tapping screw (4 x 35) ..... 2	

**Note:** The design and specifications are subject to change without notice for improvement.

### 8.2. BS-1034 and BS-1034S

Model No.	BS-1034	BS-1034S
Rated Input	10 W	
Rated Impedance	100 V line: 1 k $\Omega$ (10 W), 2 k $\Omega$ (5 W), 3.3 k $\Omega$ (3 W), 10 k $\Omega$ (1 W) 70 V line: 500 $\Omega$ (10 W), 1 k $\Omega$ (5 W), 2 k $\Omega$ (2.5 W), 3.3 k $\Omega$ (1.5 W), 10 k $\Omega$ (0.5 W)	
Sensitivity	90 dB (1 W, 1 m)	
Frequency Response	120 – 20,000 Hz	
Speaker Component	Low frequency: 12 cm (5") cone-type, High frequency: Balanced dome-type	
Input Connector	M4 screw terminal, distance between barriers: 11 mm (0.43")	
Finish	Enclosure	HIPS resin (fire resistant grade UL94 V-0 or its equivalent), off white (RAL 9010 or equivalent color)
	Net	Steel plate, off white (RAL 9010 or equivalent color), paint
Dimensions	210 (w) x 330 (h) x 80 (d) mm (8.27" x 12.99" x 3.15")	
Weight	1.4 kg (3.09 lb)	
Accessories	Speaker receptacle ..... 1, Tapping screw (4 x 35) ..... 2	

**Note:** The design and specifications are subject to change without notice for improvement.

#### Traceability Information for Europe (EMC directive 2004/108/EC)

Manufacturer:  
TOA Corporation  
7-2-1, Minatojima Nakamachi, Chuo-ku, Kobe, Hyogo, Japan

Authorized representative:  
TOA Electronics Europe GmbH  
Suederstrasse 282, 20537 Hamburg, Germany

URL: <http://www.toa.jp/>