

ASSEMBLY INSTRUCTIONS

Massage Sofa

GGIN0134BU / GGIN0134CO

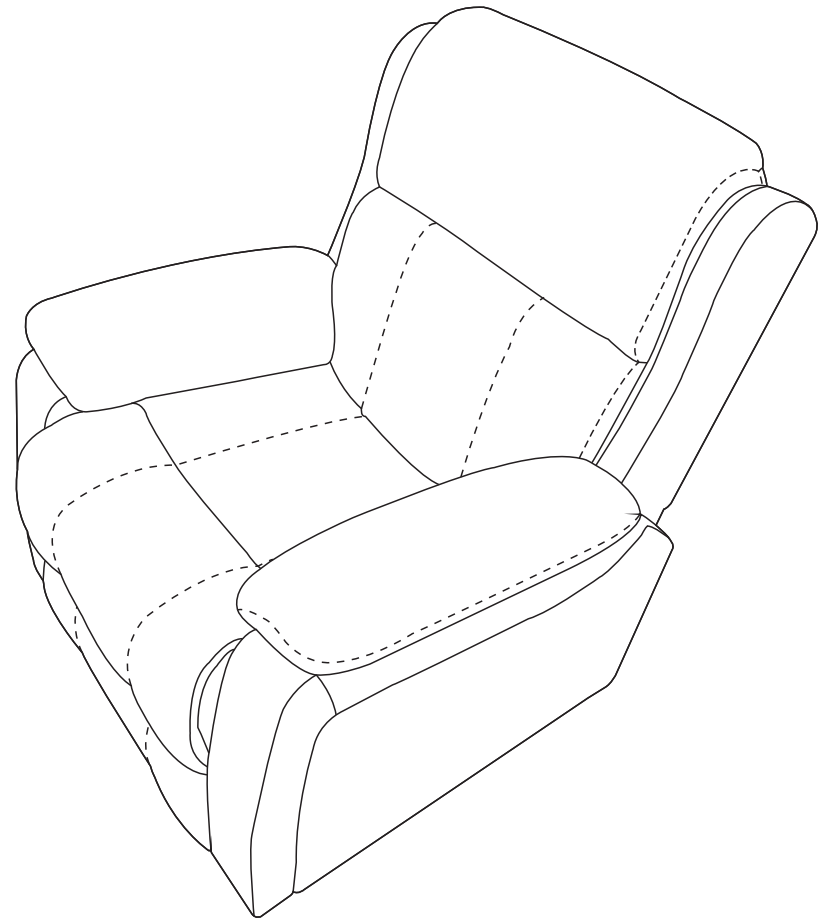

WARRANTY

So glad you have completed the assembly and can enjoy it. If you are satisfied with our products, thank you for showing your favored massage sofa to your around.

Our products come with a 12-month warranty, you can feel free to contact us at any time.

Methods :

If you choose Amazon, going to your Amazon order detail page, Order>sold by>contact seller
(guaranteed response within 24 hours)

AFTER-SALE POLICY

For return reason:

Wrong purchase, bought by mistake, no longer needed, doesn't meet expectation, a size smaller than expectation, customer need to cover the return shipping fee.

For cancel order:

Customer needs to pay for shipping fee and carrier handle fee if the item has been shipped out.

For change address: customer needs to pay for extra shipping fee and carrier handle fee if the item has been shipped out.

Customer Service:

Any problem with the product or shipping issue, please feel free to contact us, we will try our best to serve and help.

ATTENTION

Thanks for choosing our product.

- 1. Please check the manual carefully and make sure you have received all the parts.**
- 2. If there is any missing, please let us know the letter of the parts you need.**
- 3. If there is any damage, please send clear photos to us, we will check and offer you best solution soon.**
- 4. There will be 2 boxes in total for this whole product.**

FAQ

3. **Q: Can't massage or heat.**

A: There are four reasons lead to no massage and heat.

- (1) Power cord problem, please make sure the indicator lit.
- (2) Remote control problem, please make sure the indicator lit.
- (3) Please check this manual and make sure power cord and remote control connect to the right wire(there are 4 wires need to be connected).
- (4) The wires inside the chair is damaged, which we check every chair before shipped out to make sure it's ok.

4. **Q: How to connect the power and remote control with the chair?**

A: Please check manual there are 4 wires from the chair to connect the four parts.

No.1 and No.2 wire to connect the backrest and chair base.

No.3 wire to connect backrest and power cord(D).

No.4 wire to connect backrest and remote control(E).

Note: Please try to solve the problem by the way above, feel free to send the email to us for further help if it's still unavailable. We will try our best to help you solve your any concerns!

FAQ

1.Q: How to release footrest and recline?

A: (1) There is a black handle in the right side of the chair, please lift it up with some strength, then the footrest will opp up. Then you can lie in the chair with some strength about your back so that the back of the chair will recline too.

(2) When the footrest release, pls sit in more deeper of the seat, not just in front of the seat, also put two hands on both armrests, then lie down and use both back and hands strength, it will be much easier.



Note: The chair can not always keep in reclined position when you leave the chair.

2.Q: How to make the footrest go back down?

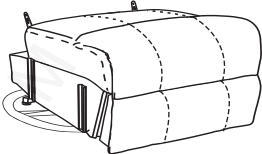

A: (1) Please try to keep the back of the chair in the seated position, It's a new chair so need more strength to lock down and you can try some times to close footrest with some force and it will work. When you hear a click sound, footrest closed.

(2) Another solution is get out of the chair and try to push the footrest back with your hands. And it will be much easier after several times use, pls note it.

Parts List Box A

<p>A</p>  <p>Chair Base</p>	<p>C</p>  <p>Left Armrest</p>
<p>1 pc</p>	<p>1 pc</p>

Parts List Box B

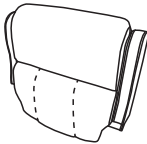
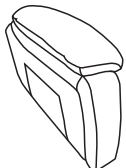
<p>D</p>  <p>Power Cord</p>	<p>E</p>  <p>Remote Control</p>	<p>B</p>  <p>Backrest</p>	<p>C</p>  <p>Right Armrest</p>
<p>1 pc</p>	<p>1 pc</p>	<p>1 pc</p>	<p>1 pc</p>

You will receive totally 2 boxes, please make sure you get 1x A box and 1x B box before assembly. Just feel free to chat us if you have any problems, we will try our best to help you solve the issue.

Assembly Instruction

Step 1

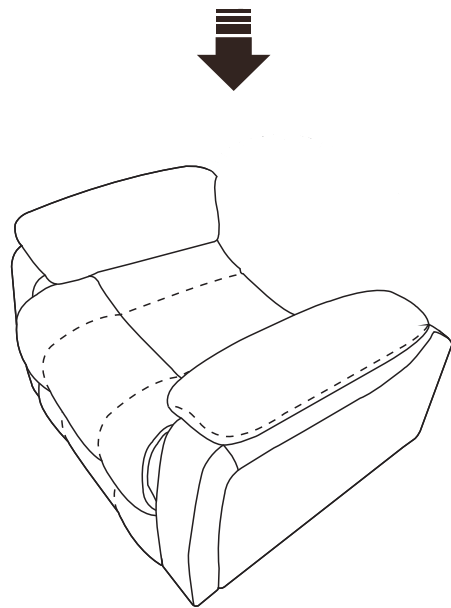
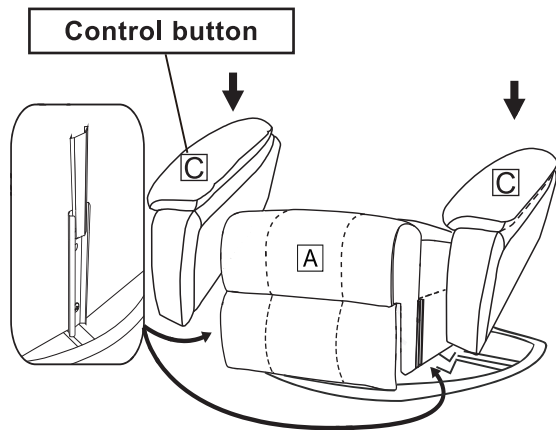

Insert two armrests to the chair base, make sure the slots on the armrests are assembled to the bottom part fully.

Assembly Instruction

How to use remote control

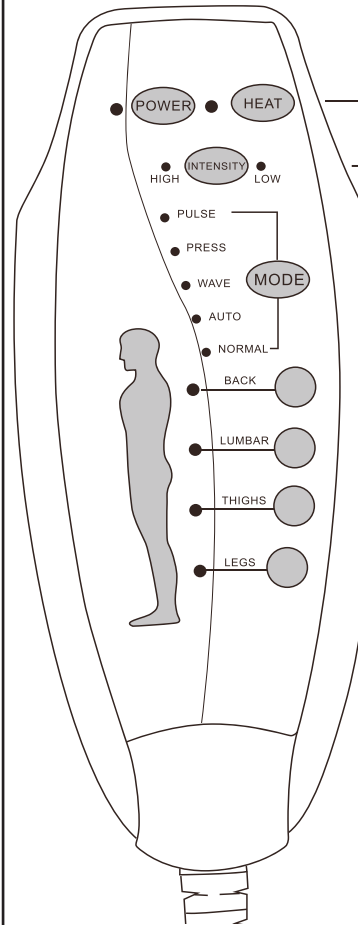

POWER:

Turn on/off remote control.

HEAT:

Turn on/off heat function for lumbar part only.

INTENSITY:

Control massage function from low or high.

MODE:

Choose one massage mode you like (pulse, press, wave, auto, normal).

You can choose 1-4 massage parts (back, lumbar, thighs, legs) to enjoy.

Assembly Instruction

How to remove the chair

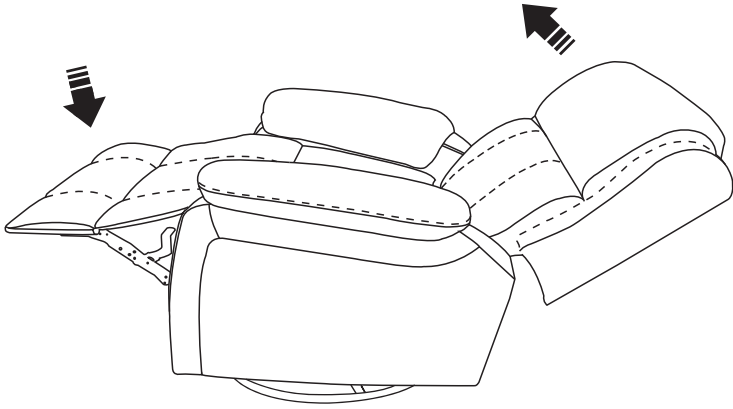

1. Sit on the chair(not recline), backrest will be back.
Note: Footrest will not close in reclined position

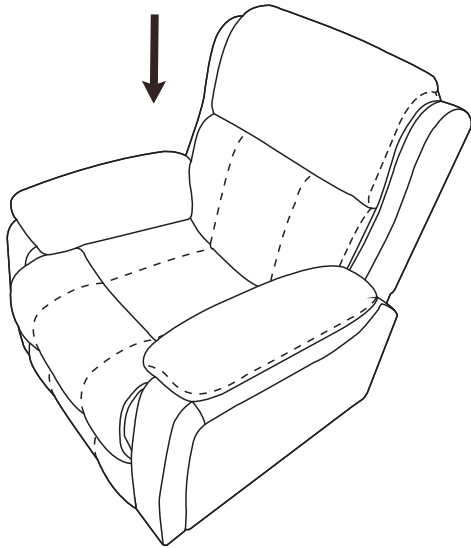

2. Press the bottom of footrest with some strength(with feet), try some times to get footrest latch down

6

Assembly Instruction

Step 2

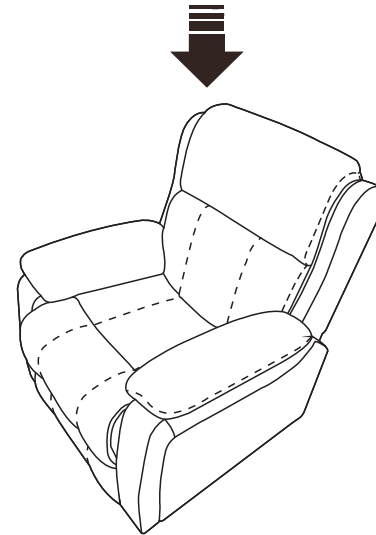
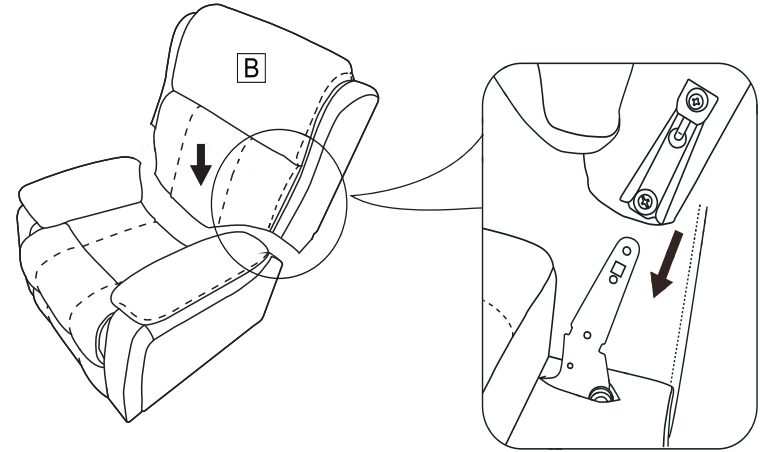

- Insert backrest to the chair base, make sure the slots on the back are assembled to the bottom part fully.

3

Assembly Instruction

Step 3

No.1 and No.2 wire connect with the backrest and chair base.
No.3 wire connects with backrest and power cord(D).
No.4 wire connects with backrest and remote control(E).

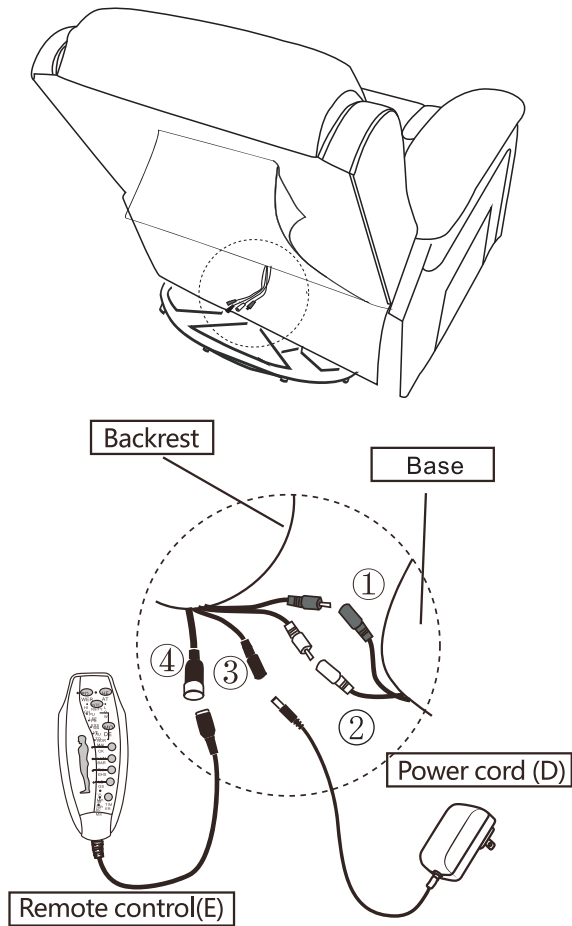

Note: Two same color wires connect.

4

Assembly Instruction

How to recline

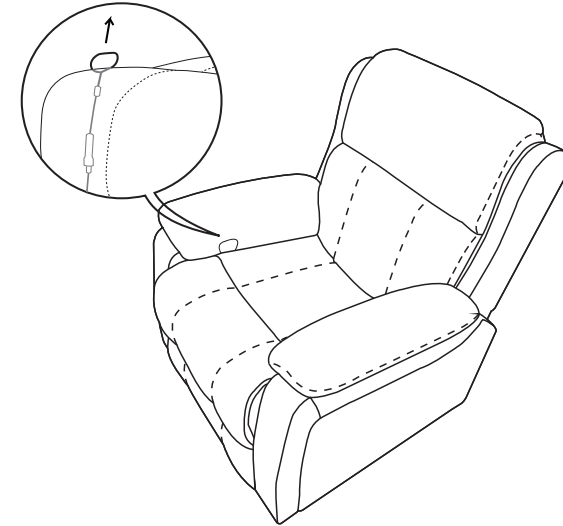

1. Lift the handle up to release footrest

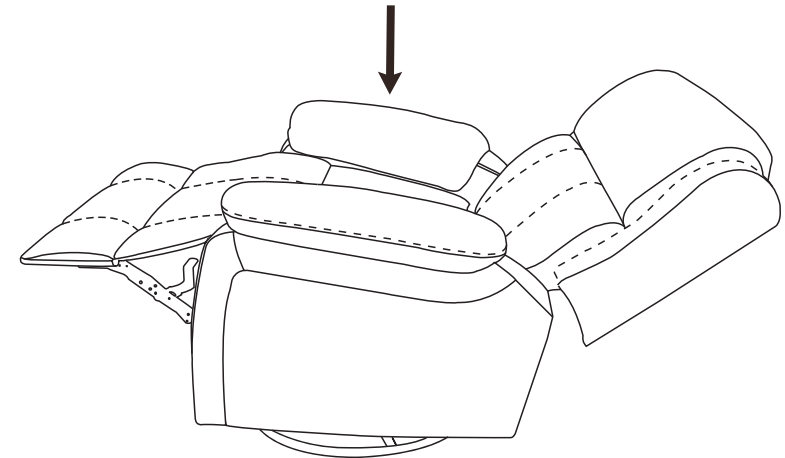

2. Have a relax on chair

5