



EBIKE USER MANUAL

LF& LM PRO Series



www.rattanebike.com

Thanks for your LM/LF PRO Ebike purchase!

We take pride in bringing you a quality product that will offer years of enjoyment. Please feel free to contact us if there are any questions about the bike.

Congratulation on your purchase of a new Rattan Ebike! The bike comes 95% assembled and here is the guide helps you get familiar with your new bike in unboxing.

The bike may need adjustments in this process as shipping can sometimes be bumpy. We recommend an adjustment and inspection by a reputable, certified bicycle mechanic before the first riding.

Please read the whole manual patiently before you use the new electric bike, for technical assistance or warranty claims contact Rattan Ebike at

Phone: (562) 488-5588 9am-5pm (PST)

E-mail: info@rattanebike.com

CONTENTS

Using this manual	01
General information	02
Assembly instructions for LM/LF PRO series	04
Adjustment for comfort and safety	11
Preparing to ride	13
Riding guidance	14
Display	16
Operating safety	25
Troubleshooting	32
Maintenance	34
Disclaimer	36
Warranty	37

USING THIS MANUALS

This manual contains details of the product, its equipment, and information on operation, maintenance, and other helpful tips for owners. Read it carefully and familiarize yourself with the ebike before using it to ensure safe use and prevent accidents. This manual contains many warnings and cautions concerning the safe operation and consequences if proper setup, operation, and maintenance are not performed. All information in this manual should be carefully reviewed and if you have any questions you should contact Rattan immediately.

The notes, warnings, and cautions contained within the manual and paragraphs are marked by the **triangular Caution Symbol** at the left side should be given special care. Users should also pay special attention to information marked in this manual beginning with **NOTICE**.

Keep this manual, along with any other documents that was included with your bike, for future reference, however all content in this manual is subject to change or withdrawal without notice.

Visit www.rattanebike.com/pages/user-manual accuracy of its documentation and assumes no responsibility or liability if any errors or inaccuracies appear within.

Rattan E-bike assumes no liability for any harm, injury, or death of the rider. Because it is impossible to anticipate every situation or condition that will occur while riding, this manual makes no representations

about the safe use of bikes under all conditions. There are risks associated with the use of any bike that cannot be predicted or avoided and are the sole responsibility of the rider.

GENERAL INFORMATION

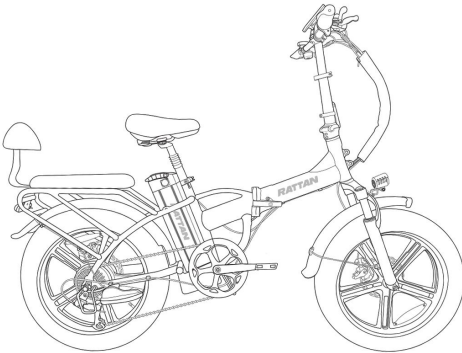

**Fully assembled LM750 PRO
High-Step**

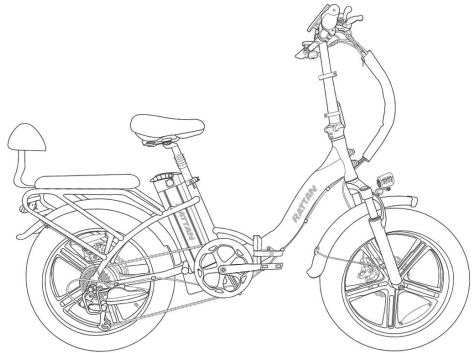

**Fully assembled LF750 PRO
Step-Thru**

Please note that your LM/LF PRO may include components that look different from those in the illustrations above and elsewhere in this manual. Such changes help ensure uninterrupted shipping. Our engineers rigorously test each component to guarantee quality and compatibility.

SPECIFICATION

Model Name	LM/LF PRO
Max. Load Capacity	300lbs

Max.Speed	Configurable to 28 MPH
Motor	48V 750W Brushless Hub
Battery	48V 13Ah Li-ion
Range Average Per Charge	Average 45miles
Wheel Size	20 x 4" Front / Rear
Tire Pressure	17-18 PSI advisable
Weight (Without battery)	25 KG (55.1lbs)

SERIAL NUMBER



There is a serial number attached on the bottom axis connecting the pedals as shown in the above picture. Please take a picture ahead once you received the bike.

You may be asked for a picture of your bike's serial number as a part of warranty requests and may also be asked to provide this number to law enforcement provided that your bike is stolen.

ASSEMBLY INSTRUCTIONS FOR LM/LF PRO SERIES



WARNING

Incorrect assembly, maintenance, or use of your ebike can cause component or performance failure, loss of control, serious injury, or death. Even if you're an experienced bike rider, you must read and understand the entire manual and any documentation provided for sub components or accessories before riding. If you are not sure you have the experience, skills, and tools to correctly perform all assembly steps in the manual, consult a local, certified, reputable bike mechanic.

1. Unpack the Bike

Open the bike box. With the help of another person capable of safely lifting a heavy object, remove the ebike from the bike box. Carefully remove the packaging material protecting the bike frame and components, as well as remove the small boxes attached to the fork. These are your charger and accessories. Please recycle packaging materials especially cardboard and foam whenever possible.

2. Unfold the Bike



Step1. The bikes come being folded as the picture one shown.

Step2. Unfold the bike and press the quick release according to the direction.

Step3. Turn the buckle into the hole of the quick release to lock it.

3. Install the Handlebar

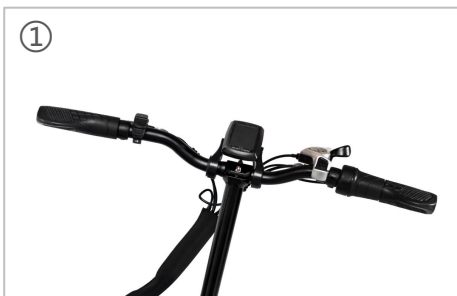



Step1. Insert the stem of the handlebar into the top tube along the groove.

Step2. Adjust the height of the handlebar then tighten the screw and lock the release.

4. Fix the Stem



5. Assemble the Rear Pedals

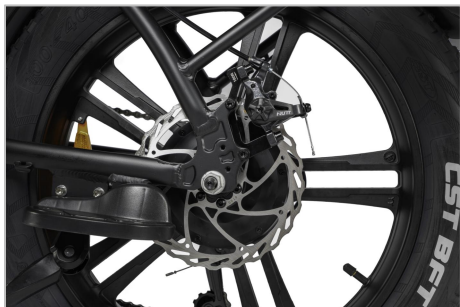

6. Install the Rear Seat



Step1. Please unscrew the screw on the picture and connect the cushion with the rear seat.

Step2. Push the cushion according to the direction the picture shown, then tighten the screw.

7. Connect the Pedals



Unfold the pedals as the picture shown.

8. Adjust the Seat



Step1. Open the quick release.

Step2. Insert the seatpost, ensuring the minimum insertion point (safety tick marks) goes into the seat tube.

Step3. Search a comfortable height of saddle by sitting on the saddle with your feet on the ground.

Step4. Close the quick-release lever using your palm.

9. Adjust the Battery



Lock on the battery



Turn the key to 'ON' position, and you could see the battery power by pressing the button on the battery.

The picture 3 shows the charging port of the battery.



Poor connection ❌



Well connection ✅

You could adjust the battery track by unscrewing the screws on the bottom to better connect the battery and the bike.

10. Adjust the Brakes

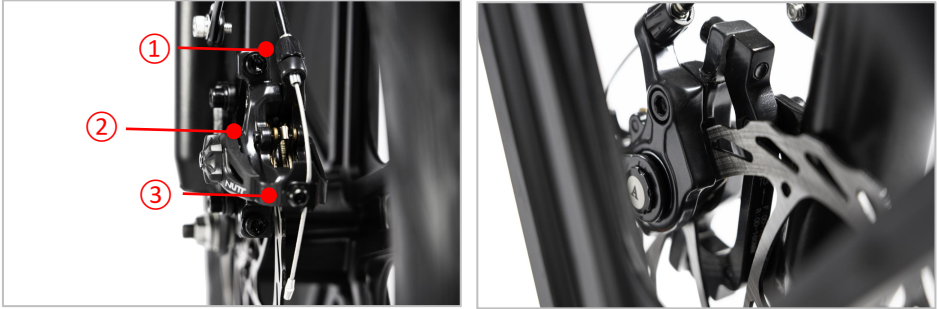

① Adjust brake disc ② Adjust brake disc ③ Adjust the brake

Step1. Make sure the brake disc is in the middle of two brake pads.

Step2. Adjust the brake tension according to your riding habits.

Step3. Loosen the screw and adjust the brake wire to the suitable brake tightness.

Step4. Loosen the screws to adjust the brake disc (abnormal noise or brake stuck when braking).

Step5. Adjust the brake pad to keep the rotor in the middle position.

Step6. Tighten the screws after each adjustment.

ADJUSTING FOR COMFORT & SAFETY

WARNING

The following steps are critical for your comfort and safety, and must be performed before your first bike ride. We recommend that you consult a bike fitting professional such as a certified, reputable bike mechanic who specializes in bike fit.

1. Adjust the Seat



A loose seat clamp or seat adjustment bolt can cause loss of control, bike/property damage, serious injury, or death. Prior to first use, be sure to tighten the seat clamp via the seat adjustment bolt properly. Regularly check to make sure that the seat adjustment bolt is properly tightened and the clamp is secure on the seat rails.

2. Adjust the Seat Height

An ideal seat height for most riders allows them to be comfortable and get the best pedaling efficiency. When the rider is seated, they should be able to place the ball of their feet on the pedal at its lowest position while their legs is almost fully extended, with the knee slightly bent. The seat should never be so high that the rider must rock sides to side or fully straighten their legs while pedaling. And the seat must never be pulled out so far that the minimum insertion point is above the seat tube (see illustration).



WARNING

Overextending the seatpost can cause it to break or fall off your bike, which will put you at very high risk of serious injury or death. Avoid this danger by inserting your seatpost into the seat tube far enough that the minimum insertion point is no longer visible.

PREPARING TO RIDE

CHECKLIST

01. Make sure all components especially fasteners and accessories are tightened. Adjust the height of the handlebar and the seat post. DO NOT raise it above the safety line.
02. Make sure the brakes can cut off the power supply to the motor, and whether it is sensitive and reliable.
03. Make sure the front and rear axle nuts are tightened.
04. Make sure the display, brakes and lights can work properly.
05. Make sure the chain is tight.
06. Make sure the pedals and all the connection parts are firm and would not be loose, and whether the crank is flexible without jamming.
07. Check if the tire pressure exceeds the recommended one marking on the side of tire walls.
08. Make sure the throttle works well without jamming, and whether it feels tight or loose when pressing the throttle.
09. Make sure the battery has been locked.
10. Check if the total weight the bike carried is higher than 300lbs, which is the maximum weight capacity of the bike.

RIDING GUIDANCE

WARNING

Incorrect assembly, maintenance, or use of your ebike can cause component or performance failure, loss of control, serious injury, or death. Even if you're an experienced bike rider, you must read and understand the entire manual and any documentation provided for sub components or accessories before riding. If you are not sure you have the experience, skills, and tools to correctly perform all assembly steps in the manual, consult a local, certified, reputable bike mechanic.

Three Modes

• Pedal Mode

This mode does not require any power. It allows the ebike to work as other regular bikes. You will be automatically switched to this mode when the battery dies while riding.

• Electric Mode

Turn on the display and press the throttle slowly to get started. When release the throttle slowly, the riding speed will gradually drop until power off.

• Pedal Assist Mode

The rider can engage the pedal assist system (PAS) while pedaling, and it will call up assistance from the motor to help propel the bike forward. Pedal assist uses a cadence sensor built into the drive train of the bike. The cadence sensor detects when the rider revolves the pedals and signals the electric motor to provide the level of pedal assistance (0-5)(0-4) that the rider has selected.

Notice Accelerate slowly and use the pedal assist at the beginning of riding. When riding against the wind or climbing the hill, avoid using the pedal assist to protect the battery.

• Throttle Mode

The throttle is located on the right side of the handlebar. The rider can use it with a twist of the throttle grip to propel the bike forward without pedaling.

To engage the throttle while riding, slowly and carefully rotate it toward yourself. The more you twist, the more powerfully the motor will propel the bike forward. Once you release the throttle or apply the brakes, the throttle will no longer propel the bike forward. Always keep one hand on the brake lever and be prepared to squeeze the lever to disengage the throttle if needed, or turn off the bike to prevent accidentally engaging the throttle.

DISPLAY

• Material

Caser and Cover and Press button: ABS,

LCD window: PMMA

• Dimension

Outside and mounting dimensions(mm)

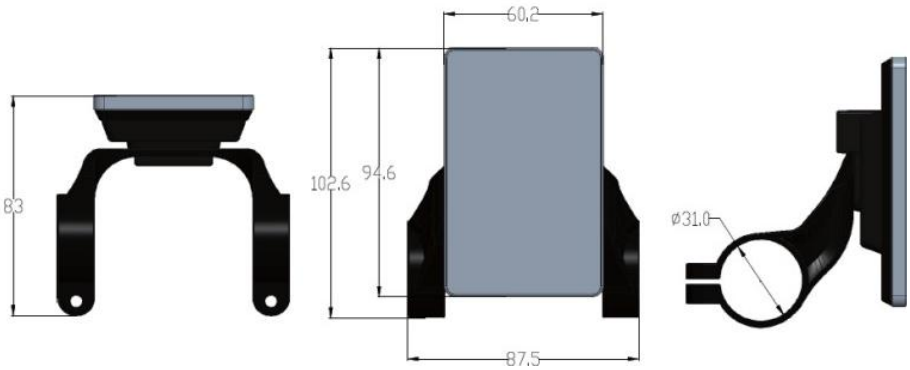

Press button outside and mounting dimensions (mm)

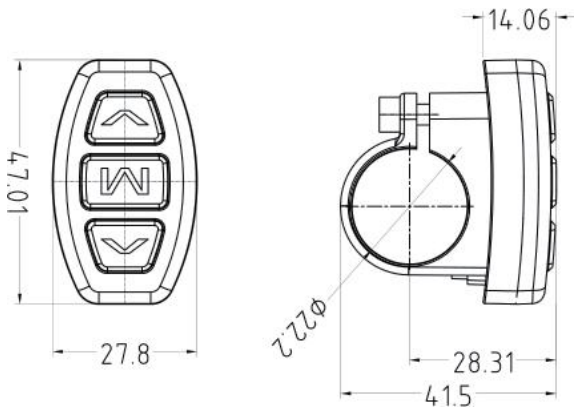

• Installation

1. Install the display in the middle of handlebar, then adjust to suitable angle, install the press button to left side of handlebar.
2. Power off the device, connect the device to controller.
3. Power on.

• Overview of GD06

1. UART protocol: Equipped with independent press buttons
2. Speed: Real-time SPEED
3. Kmh/mile: Kmh/MPH according to habit
4. Battery level: Indicates the battery level in real time
5. Head light control: Press button to power on/off
6. Back light adjustment: 3-level adjustment
7. Assist level: From 0 to 5, press button to change assist level, 0-no assist, 5-default value
8. Distance: ODO/Trip/Driving duration
9. Error code: Please refer to appendix table 1 for definition
10. 6km mode: In this mode, it will display “WALK” on the screen
11. Parameter setting: Set parameters, such as: wheel size, speed limit etc

• Presentation of Screen

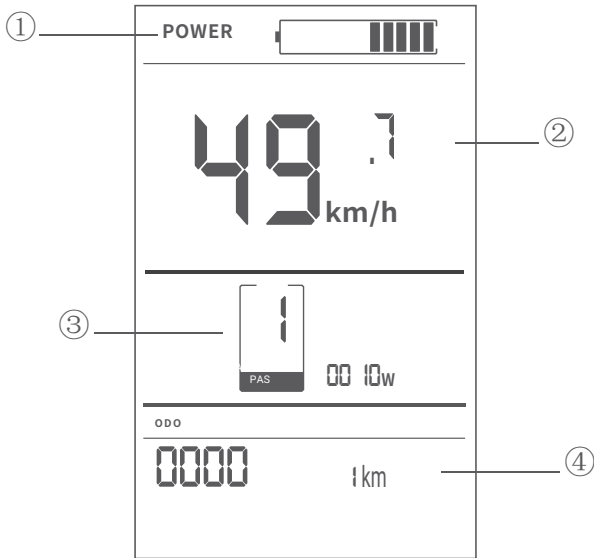

- ① Battery Level Indicator
- ② Speed
- ③ Pas level
- ④ ODO Mileage

1. Battery level: 5 levels, voltage interval could be customized
2. Speed: Real-time SPEED
3. Speed unit: Kmh/MPH
4. 6km mode
5. Assist level: actual assist level 0~5
6. Head light icon: indicates when head light and back light are on
7. Distance: Trip/ODO
8. Driving Duration
9. Error code: " ERROR " and code when there is error

• Press Button Definition

GD06 uses independent press button, in total three buttons:



UP



MODE



DOWN



• Operation Instructions

1. Power ON/OFF

When the power is off, Long press  during 3seconds, screen will display all contents and start to normal working mode, and controller will be turned on When the power is on.

Long press  during 3 seconds,screen will be powered off, and controller will be turned off. If no any operation both on bike and display during 10minutes(time could be set), the display will turn off automatically, in this case, no power consumption for both display and controller.



2. ODO/TRIP

Long press  and  switch different speed information, Real time speed (SPEED) → Max speed (MAX SPEED) → Average speed (AVGSPEED).

3. ODO/TRIP/ Driving Time/Error Code

Short press  to switch ODO/TRIP/ Driving Time/Error Code Trip (Single trip distance)→ODO(Accumulated distance) →TM (Driving Time)→REE (Error Code).



4. Assist Level

Short press  or  to change assist level, default value is level 1.



5. Head Light Control



Long press  for 3 seconds turn on/off the head light.

6. 6km Mode



When the bike is stopped, long press  and  , will enter 6km/h mode, the speed will be 4.5~7.5km/h according to different road conditions, “WALK” will show up on screen, long press again or short press ,will quit 6km/h.

• Parameter Setting

1. When the display is powered on, long press  and  , will enter parameter setting mode, in this mode, can change parameter values, long press again and will quit parameter setting mode or no operation during 10s will also quit this mode.

2. In parameter setting mode, short press  /  will change parameter value, short press  will save current value and switch to next parameter.

① P01-back light lightness :

short press  /  will switch from 1 to 3, Level 3 is lightest.
Level 2 is default value.



② P02-kmh/MPH :

Short press  /  to Switch kmh/MPH.

③ P03-Working voltage :

short press  /  to switch 24V,36V,48V.

④ P04-Auto shutdown time:

short press  /  to switch from 0 to 60, it is the time (in minutes) to shut down the screen automatically if no operation 0 means never shut down, Default value is 10 minutes.

⑤ P05-Number of Assist levels:



Short press  /  to change level 3->5->9.

3: 3 assist levels

5: 5 assist levels

9: 9 assist levels



⑥ P06-Wheel size selection:

short press  /  to switch wheel size,step:
16 inch, 20 inch, 22 inch, 24 inch, 26 inch, 700C, 28 inch.

⑦ P07-Number of magnets for speed sensor :

short press  /  to switch from 1 to 15.

⑧ P08-speed limit :

short press  /  to set the speed limit from 10 to 41km/h.

⑨ This feature is reserved: display P09, invalid.

⑩ This feature is reserved:
display,invalid.



⑪ P11-assist sensitivity setting :

short press  /  to switch from 1 to 24.

⑫ P12-assist starting power setting:

short press  /  to switch from 0 to 3.

⑬ P13-Assist magnetic disc types:

short press  /  to switch from 6->6->8->10->12 ,
different numbers of magnets.

⑭ P14-Current limit for the controller:

short press  /  to switch from 1 to 20A

⑮ P15-Turn on/off the cruise control:

short press  /to /  switch from 0 to 1

0: the cruise control turned off

1: the cruise control turned on

⑯ P16-Reset ODO distance:

long press  during 5 seconds.

⑰ P17-The signal direction of the booster sensor:

short press  /  to switch from 0 to 1;

0: Booster signal;

1: Power signal negative.

⑱ 18-Shift gears with gear :

short press  /  to switch from 0 to 1;

0: Don't shift gears

1: Shift gears.

⑲ P19- Throttle the 6KM function :

short press  /  to switch from 0 to 1;

0: Turn to the normal

1: Throttle 6Km.

• Specifications

1. Power supply: 24V, 36V, 48V

2. Rated current: 10mA

3. Max current: 30mA

4. Leakage current after power off: <1uA

5. Current supply to controller: 50mA

6. Working Temperature: -10~60°C

7. Storage temperature: -20~70°C

• Error Code Definition

When an error appears, GD06 will notice users by different codes, please refer to table 1 for different codes:

Code (Decimal)	Signification
0	Normal
6	Low Battery level
30	Communication failure
21	current sensor fault
22	Throttle failure
23	Failure of motor phase line
24	Motor hall failure
25	Brake abnormality

• Notices

Power on and power off must keep an interval of at least 3 seconds, please don't press “ **M** ” button frequently when it is powered off. When the temperature is under -10°C, the screen will be a little darker than normal, when the temperature increases, the screen can go back to normal.

• FAQ

Q: Why I can not power off?

A: Please check connection between display and controller.

Q: What can I do if an error code displays?

A: Find a nearest shop to get repair. We offer 1 year of warranty for quality issue except frame is broken.

• Version

This is a universal manual for GD06.It could be customized by each client. Please confirm all details before purchasing.

OPERATING SAFETY



WARNING

Ride Rattan by taking the sensible measures outlined in this section to maximize your safety. Bicycling is an exciting, delightful, and practical way to get around, but like any sport, it involves risk of injury and death. By choosing to ride a bike, you assume responsibility for those risks.

Be Thoroughly Educated About Your Bike Before Riding It.

Practice riding your bike, braking, shifting gears, and using the throttle and pedal assist systems in a controlled location before venturing into traffic or other risky conditions. The electrical system on your ebike offers various levels of power assistance and lighting for different operating conditions and user preferences. Be sure you understand these features before riding.

The throttle should provide smooth acceleration when gradually applied. If the pedal assistance, throttle, or lighting is functioning abnormally, intermittently, or not at all, please discontinue using your ebike immediately and contact Rattan Ebikes Product Support for assistance. Take extreme care getting to know and learn to control the pedal assist and brake systems.

Your LM/LF PRO is probably heavier than other bikes you've ridden, and it will handle quite differently from lighter bikes, especially when you're accelerating or decelerating. Learn to maintain a comfortable stopping distance from all other objects, riders, and vehicles at different speeds, conditions, and with varying payloads.

Some localities may require ebike riders to be older than 16. It is your

responsibility to know and obey local regulations regarding the rider age and other qualifications.



WARNING

Riding any bike under the influence of alcohol, drugs, or any substance or condition that could impair your motor function, judgment, reaction time, or ability to safely operate a vehicle puts you at **VERY HIGH RISK** of serious injury or death. Operate bikes and other vehicles only when you're sober and otherwise physically and mentally prepared to ride safely.

Riders must also have the physical ability, reaction time, and mental capability to understand and obey all local laws governing ebike usage and to manage traffic, variable road conditions, and sudden situations. If you have an impairment or disability (e.g., visual impairment, hearing impairment, physical impairment, cognitive or language impairment, seizure disorder) or any other limitation that could affect your ability to safely operate a vehicle, consult your physician before riding any bike.

Obey All Relevant Local Laws

It is your responsibility to research and understand relevant laws where you ride your bike. Such laws may cover required helmets and safety gears, required lights and reflectors, required hand signals, where you can legally ride a bike (bikes and ebikes may have different restrictions), how fast you can go, what (if any) cargo or passengers you can carry, the rider age, and more.

Before using public transportation—buses, trains, etc.—to transport your ebike, check with the relevant transportation authority for any rules governing weight limits, tire widths, lithium-ion batteries, or any other rules that might pertain to ebikes. When you ride on the road, assume you must, at minimum, follow all of the rules that cars must follow. For additional information regarding traffic and vehicle laws, contact the road traffic authority in your area.

Carrying Loads (Cargo Or Passengers) Safely

Carrying Cargo

Follow these recommendations to maximize safety when using your LM/LF PRO to carry cargo or passengers.

1. Carrying extra weight significantly affects braking, acceleration, turning, balancing, etc. These effects can be increased by challeng-

ing riding conditions, such as when roads are wet or slick. Hills that are normally easy to climb or descend without cargo can become challenging or even dangerous once extra weight is loaded onto the bike. Extra weight will increase the time it takes to slow the bike when braking.

2. Practice riding with light cargo in a flat, open area that's free of obstacles before attempting to ride with heavier loads, and/or in wet or hilly conditions.
3. With extra weight on your bike, it's more important than ever to use both front and rear brakes, and always engage the rear brake first to prevent excessive strain on the front wheel and fork and to prevent loss of control. Ensure both front and rear brakes are properly adjusted, maintained, and applied.
4. Load cargo as low as possible to keep the bike's center of gravity low and improve stability.
5. Hold onto the bike when loading and carrying cargo and/or passengers. The kickstand is not designed to be used for loading cargo or passengers. Do not assume the bike is stable and balanced when using the kickstand.
6. Ensure cargo loads are properly secured and periodically check that nothing loosens, risks interfering with any moving parts, or risks

touching or dragging on the ground.

7. When carrying heavy loads or passengers, plan your routes to avoid challenging hills and other hazards.
8. It is always the rider's responsibility to ensure cargo or a passenger loaded on the ebike will not interfere with the rider's ability to safely operate the ebike.



WARNING

Carrying cargo or passengers significantly affects braking, acceleration, turning, and balancing, which can increase the risk of falls and other accidents, potentially leading to property damage, serious injury, or death. To minimize such risk, practice riding with light cargo in a flat, open area before attempting to carry heavier cargo or passengers, especially on roads or hills and in wet conditions.

Carrying Passengers

Your LM/LF PRO is designed to carry one small child on the back.

WARNING

1. Using your LM/LF PRO to transport a passenger who is not the appropriate size or age for your child seat, or who does not have the health, motor control, or impulse control to ride safely as a passenger, can lead to serious injury or death of the rider or passenger. Read and understand the specifications of any child seat you purchase and all safety-, cargo-, and passenger-related information in this manual. It is your responsibility to assess the ability of a potential passenger to ride safely. If you're not certain, consult a physician.
2. Leaving a child unattended on a bicycle creates a VERY HIGH RISK of the bike tipping over, causing serious injury or death. Always remove your child from the bike before you look away or walk away from the bike.
3. To reduce the risk of injury, always closely supervise children if and when you use your LM/LF PRO near them.
4. Serious injury or death can occur if clothing or body parts contact either wheel or other moving parts while the bike is in motion.

Carrying Pets

Rattan Ebike understands that you may want to bring your pet along

your bike adventures and we urge you to take great care to protect your furry friend and yourself. We cannot recommend any pet carrier or restraint system that we have not tested for compatibility and safety with your ebike from Rattan Ebikes.

 **WARNING**

Transporting a pet using any bike puts you and your pet at risk of injury or death, especially if the pet distracts you, affects your balance, interferes with moving bike parts, etc. It's impossible to anticipate every situation that can occur while riding with a pet. If you carry a pet on any bike, you assume any and all inherent risks.

TROUBLESHOOTING

Problems	Most Common Solutions
Battery cannot be charged	<ol style="list-style-type: none">(1) Use a multimeter to check if the battery still have voltage.(2) Check if the charger indicator is normal. (Red light means charging, green light means fully charged.)(3) The battery case is damaged, stop using the battery and contact us.
The brakes make abnormal noise	Adjust the brake pads or brake discs, as we noted in the picture above.

Problems	Most Common Solutions
Motor makes abnormal noise	Lift the rear wheel off the ground and press the throttle to see if the rear works. Then contact us with a video for further solutions.
The tires got flat or could not be inflated	The tires will not be filled with air. Ride the bike after inflating the tires. (The pumping range is 17-18 psi)

Bike won't work

Possible Causes	Most Common Solutions
Insufficient battery power	Charge the battery
Battery hasn't been turned on	Turn on the battery by holding the battery button for at least three seconds
Battery not fully seated in tray	Install battery correctly
Faulty connections	Clean and reconnect connectors
Brakes are squeezed	Disengage brakes
Battery non-functional	Test the battery voltage with multimeter and contact us

MAINTENANCE

Basic Bike Care

- ① Fully charge the battery for the first use. (more than 6 hours)
- ② Do not use the battery in low power level.
- ③ Must use the specified charger for charging.
- ④ Do not charge the battery at high temperature (over 212 Fahrenheit/100°C). Charge at a ventilate place.
- ⑤ If the battery is not in use for a long time, charge the battery at least once a month to keep the battery active.
- ⑥ Keep the battery away from water or any other liquid.
- ⑦ Turn off the battery when not in use.
- ⑧ Fully charged the battery before use each time. It will extend the battery life. If there are problems with the battery, do not charge it anymore and contact us for further solutions.

Frame Maintenance

- ① Pay attention to the frame maintains. Wipe the bike and keep it dry.
- ② Any merchandise with electrical components is not recommended to be exposed to water.
- ③ The warranty of the Rattan does not cover water damage.
- ④ Please try not to store or use the bike in wet condition.

Brake Maintenance

- ① Check brake pads regularly.
- ② Check the brake disc regularly to prevent deform. If it is a hydraulic brake, check regularly to see if any oil leakage.
- ③ Clean the brake regularly.
- ④ Using the front brake by itself can cause excessive stress on components, damage to the bike and parts, loss of control, injury, or death. Always apply the rear brake before applying the front brake, using both brakes for all operations.

Motor Maintenance

- ① Do not try to disassemble the motor.
- ② If there is any problems with the motor, contact Rattan with a video.

Tire Maintenance

- ① Check regularly to prevent air leak.
- ② Check spokes regularly.

Derailleur Maintenance

- ① Check the rear derailleur regularly to see if it changed to every gear (contact us for the video about how to adjust the shifter).
- ② Check the rear derailleur guard to see whether it bent to affect the derailleur or not.

DISCLAIMER

Ebike performance will vary with rider weight, cargo weight, rider/cargo shape (both contribute to drag), terrain, tire pressure, brake adjustment, throttle vs PAS usage, pedal power, battery charge level, ambient temperature and wind conditions.

Rattan Ebike should be operated in accordance with the Rattan Ebike manual provided with the bike. The warranty will be activated automatically from the date of shipment in a period of one year when Rattan Ebike used in accordance with the user manual. All other obligations and conditions or liabilities, including obligations for consequential damages are hereby excluded. Damage caused by failing to adhere to instructions and warnings issued by Rattan Ebike is not covered under warranty.

We will replace any parts deemed to have been damaged during shipping. Shipping damage must be reported to Rattan Ebike within 14 days of shipment arrival. This applies to all products including bikes and accessories. You will NOT be refunded as compensation for your time or efforts replacing damaged parts. Replacement parts will not be sent until photographic evidence has been provided to Rattan Ebike.

Rattan Ebike may request additional documentation (such as video) to assist with accurately diagnosing the problem and processing the warranty claim.

For warranty services, please contact Rattan Ebike online support by email at **info@rattanebike.com**. Bikes or parts returned without proper documentation may result in delayed service or denied warranty coverage. All unauthorized returns will be refused.

Damage as a result of an accident is not covered under this warranty, and Rattan Ebike is not responsible for repair or replacement of damaged bikes or parts.

Rattan Ebike reserves the right to change the warranty at any time and without notice. Under no circumstances is Rattan Ebike responsible for any damage resulting from damaged, defective, or improperly secured parts. This includes, but is not limited to, damage to personal property, personal injury, or death.

LIMITED WARRANTY

Your bike's warranty and other binding legal terms (e.g., terms of purchase, etc.) are subject to change at any time. To view the current warranty, please go to **www.rattanebike.com/pages/warranty-policy**.



amazonsupport@rattanebike.com

Contact us for more owner benefit.