

# AQUASPRAY®

MOBILE WATER FILTRATION SYSTEMS

## INSTRUCTION MANUAL



equip2clean®

## **TABLE OF CONTENTS**

---

Product overview .....	1
Table of products specifications and parameters .....	2
Product diagrams .....	3
Safety information .....	4
Intended uses .....	4
Important notes before use .....	4
Installation and startup .....	5
Installation and accessories .....	6, 7, 8
Use and operation .....	8
FAQ .....	9

Thank you for your choosing Aquaspray® Water System for your water filtration needs.

This manual will help you get set up and begin using your product right away. Inspect Aquaspray® unit and all components. Read warnings and operating instructions.

## **1. SYSTEM OVERVIEW**

By employing the ion exchange principle, we are able to produce pure water through the deionization process. This innovative method removes the minerals that cause unsightly spots in the water, resulting in a pristine final product. When used as intended, this system will produce low total dissolved solids or TDS (less than 20 ppm) pure water for spotless cleaning.

### **1.1. PRODUCT OVERVIEW**

Aquaspray® Water Filtration System extracts all solids from your water to produce laboratory grade water which leaves a spot free rinse every time. Whether it's for home use, window cleaning, solar panel washing, mobile car detailing, boat cleaning, or any number of professions that require deionized water, this pure water system allows you to make deionized water anywhere at a fraction of the cost.

### **1.2. PRODUCT FEATURES**

- ✔ Easy 5 minute setup.
- ✔ Standard garden hose hookup/no electricity required.
- ✔ Instant deionized water for your mobile washing business or at home use.
- ✔ No scratches on your vehicle from hand drying with towels or chamois.
- ✔ No more waterspots!

### **1.3. APPLICATIONS**

- ✔ This product is versatile, easy to use.
- ✔ Ideal for automobile & motorcycle cleaning and detailing and window cleaning.
- ✔ Can be used for cleaning window glass, billboards, signs, fascias & soffits also.

<b>MODEL</b>	<b>AQUASPRAY® 10L</b>	<b>AQUASPRAY® 15L</b>	<b>AQUASPRAY® 25L</b>	<b>AQUASPRAY® 2 STAGE</b>
Function	Spotless filtered water			
Body Size	18 x 18 x 39 cm	24 x 24 x 48 cm	21 x 21 x 105 cm	40 x 25 x 90 cm
Carton Size (as packed)	27 x 27 x 42 cm	26 x 40 x 50 cm	22 x 22 105 cm 28 x 34 x 40 cm (Two Carton)	61 x 27 x 83 cm
Operating Temperature	40°F – 100°F (4°C – 40°C)			
Total Gross Weight (as packed)	6.3 kg	11.3 kg	24.5 kg	21.5 kg
Capacity (parts per million)	50 ppm	2580 Litres	5150 Litres	12870 Litres
	100 ppm	1290 Litres	1900 Litres	4730 Litres
	200 ppm	570 Litres	1415 Litres	4840 Litres
	300 ppm	440 Litres	870 Litres	2180 Litres
	500 ppm	260 Litres	515 Litres	1290 Litres
Recommended Flow Rate	4.5 LPM		9.5 LPM	

**NOTE:** When used as intended, this system will produce low total dissolved solids or TDS (less than 20 ppm) pure water.

High-strength polymer constructed head

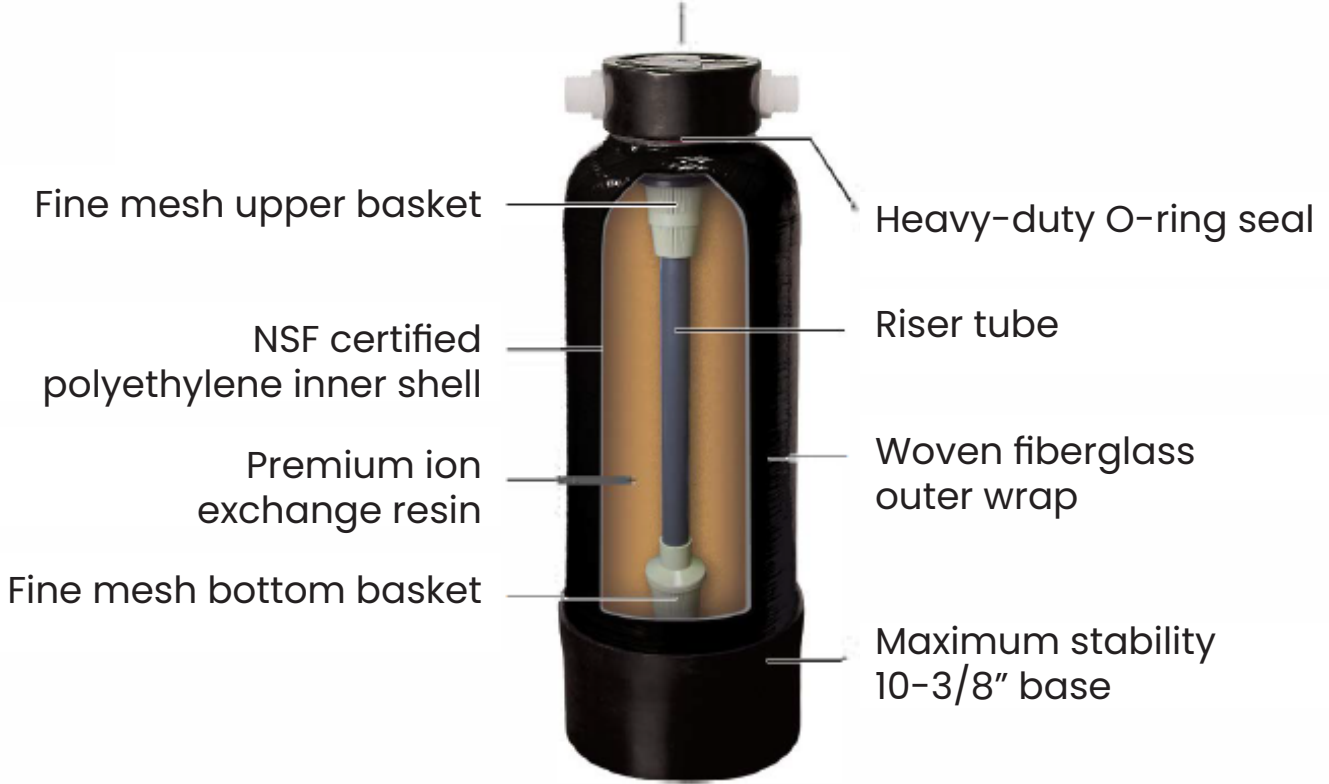

## 2. SAFETY INFORMATION

### 2.1. GENERAL WARNINGS

- Before first use or after prolonged periods of non-use it is recommended that the system be flushed thoroughly. Let water run for 1-2 minutes before using.
- The system is only to be used with cold water.
- The system usage must comply with all local laws.
- Testing was performed under standard laboratory conditions, actual performance may vary.
- Never direct water towards eyes or face.
- Keep out of reach of children and pets. Do not allow product to be used as a toy. Close supervision is necessary when any appliance is used by or near children.
- To prevent electrical shock, do not use near any sources of electricity, including electric and power lines.
- Do not use on electrical equipment or appliances.
- After unpacking the product, be sure to carefully dispose of any plastic bags to avoid injury.
- Drain the water from the unit after each use.
- Do not allow unit or resin to freeze.
- Ensure work area has sufficient water drainage.
- Turn off water supply when not in use.

### 2.2. INTENDED USE

This product is designed for personal use only. Always ensure that the product is properly assembled, regularly maintained and used only as intended.

This product is meant to be used outside and stored at a temperature between 40°F ~ 100°F. Use this device only for water treatment to reach an optimal water quality for spot-free cleaning. Any other use, especially water treatment for food production (e.g. beverages) or drinking water consumption is prohibited.

### 2.3. IMPORTANT NOTES FOR USING AQUASPRAY® WATER FILTRATION SYSTEM

- Please keep flow below 9.5 LPM
- DO NOT allow water above 100°F to through this system
- If there is water leakage at the connection of the filter housing, apply silicone grease to the O-rings.

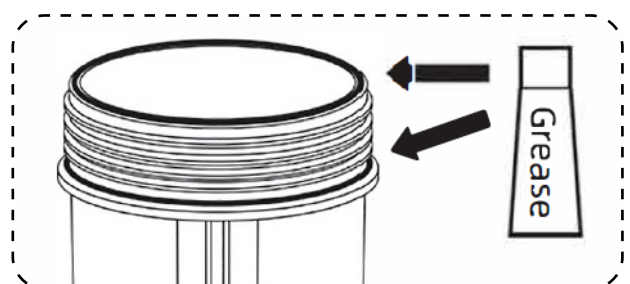

### 3. INSTALLATION AND STARTUP

#### 3. 1. FILLING RESIN FOR AQUASPRAY® 10L, 15L, 25L & 2 STAGE CART



Pull out the riser tube



Connect plastic cap to the riser tube and put it in centre of the tank



Pour in the resin



Insert the centre tube firmly into the constructed head then install into the tank

### 3. 2. INSTALLATION ACCESSORIES

#### MODEL: 10 LITRE



#### MODEL: 15 LITRE





**MODEL: 25 LITRE**

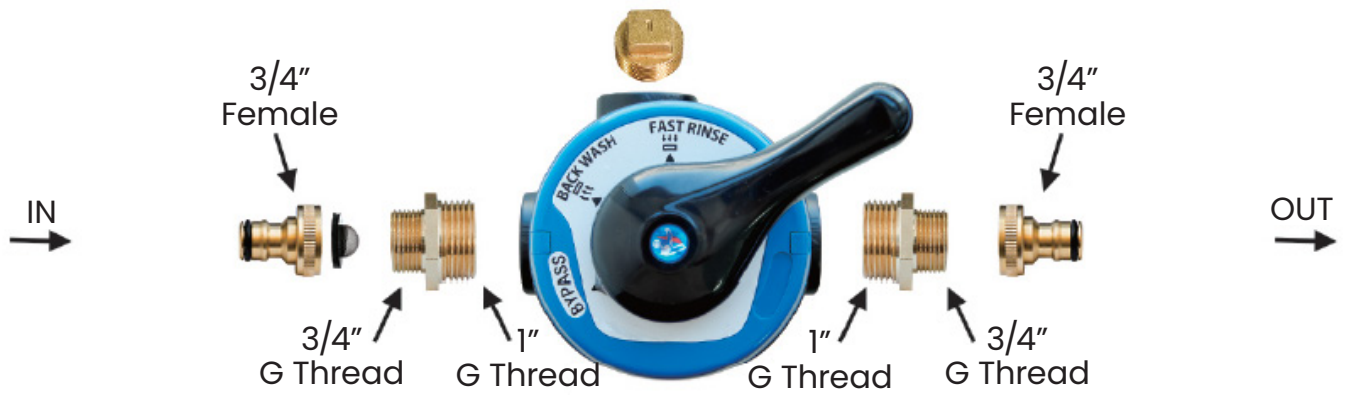

**3.3. INSTALLATION FOR AQUASPRAY® MOBILE 2 STAGE WATER FILTRATION SYSTEM**

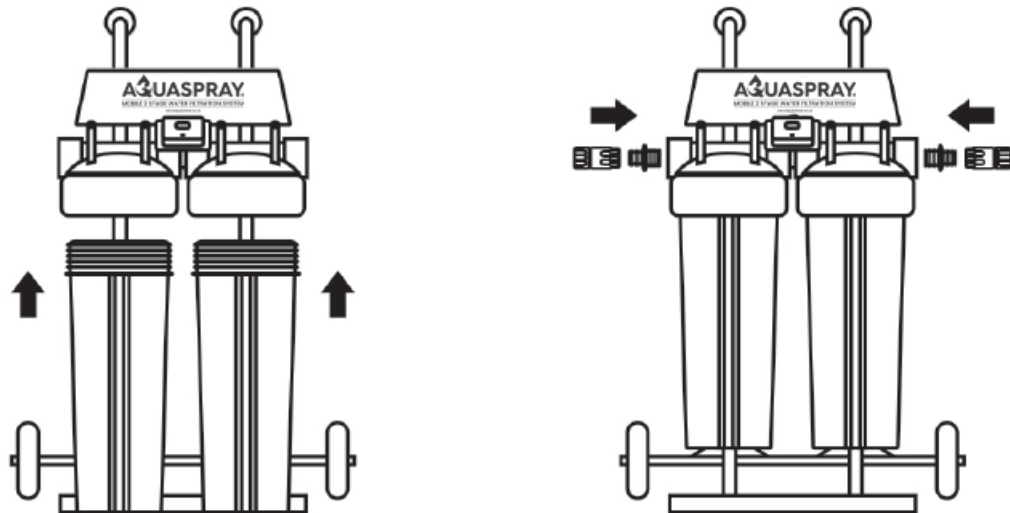

**3.4. INSTALLATION ACCESSORIES**



### 3.5. TDS METER

- Aquaspray® 10L, 15L & 25L filters
- DO NOT come with a TDS Meter.
- Aquaspray® Mobile 2 Stage Water Filtration System DOES INCLUDE TDS Meter (without battery). Battery required is CR2032 3V

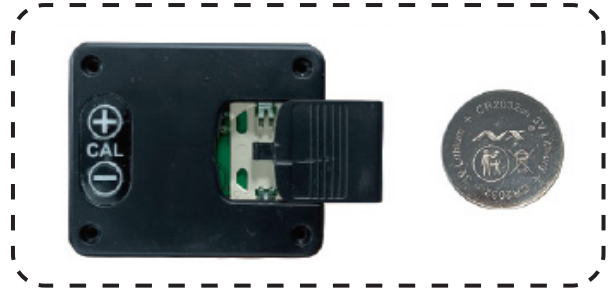

### 3.6. STARTUP

1. Locate water supply.
2. Choose a stable location where product is securely on the ground to minimize toppling.
3. Connect one end of the water pipe to the “IN” side of the system and other end to your water supply.
4. Connect your water pipe and spray gun to the “OUT” side of the system.
5. Slowly turn on the water supply, and press the “ON/OFF” button on the TDS meter to turn it on. Water must be flowing for accurate TDS meter reading.

### 4. USE AND OPERATION

**NOTE:** We recommend testing the TDS (total dissolved solids) of your water supply, in order to determine approximately how many times you can use your Aquaspray® filter before replacing the resin filter.

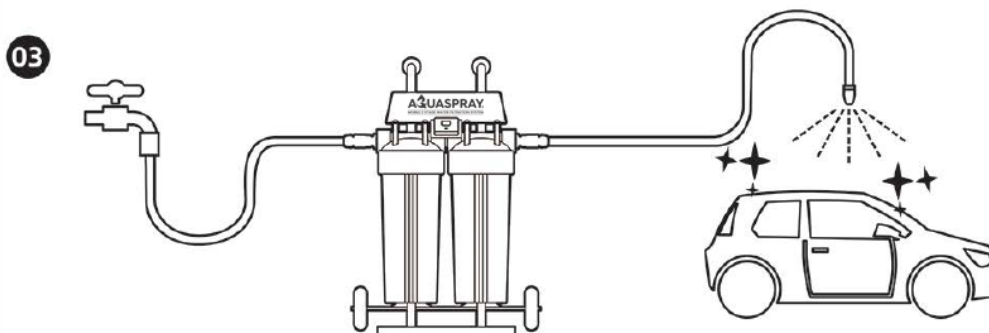
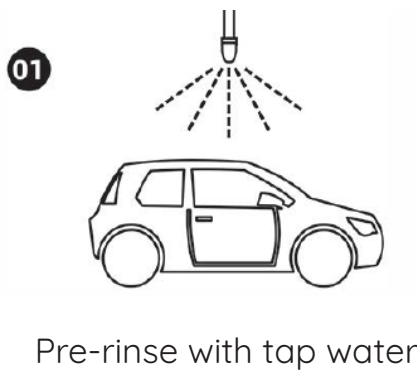

Finally connect to Aquaspray® filter and begin rinsing for a spot free shine

## **AFTER EACH USE**

1. Shut off tap water supply.
2. Disconnect hoses from both ends of the unit.
3. Drain water from the unit by tilting the top of the unit forward and allowing water to drain.

## **5. CARTRIDGE/RESIN REPLACEMENT**

Aquaspray® deionized filter cartridges and resin are replaceable, If you need to replace it, please contact equip2clean®

Please be sure to replace it with the water supply shut off

- Remove the filter housing and take out the cartridge.
- Insert the replacement cartridge and install the filter housing.

## **6. STORAGE**

- The system should be stored in a dry place at a temperature between 40°F-100°F.
- Do not allow product to freeze or damage might occur.
- Storing the product in an upright position is recommended.

## **7. FAQ**

**Q: Can I run heated water through the Aquaspray® filtered water system?**

**A:** It is recommend you use cold water

**Q: Should I use Aquaspray® filtered water for the whole process of car washing?**

**A:** It is recommended to use in the final rinse

**Q: What value of PPM will leave my vehicle with a spot free rinse?**

**A:** We have provided these parameters:

Excellent level: less than 15 ppm.

Satisfactory range: Greater than 15 ppm but less than 50 ppm.

(Depends on coloration of vehicle, degree of stainless and one's individual acceptance level).

**Q: What do I do with the used resin once I refill the tank?**

**A:** The resin is non-hazardous and can be disposed through normal waste disposal processes. Always dispose in accordance with local regulations.

**Q: Is the filtered Aquaspray® water safe to drink?**

**A:** We do not recommend to drink it.

**NOTE:** For use with municipally treated water only. Do not use with water that is microbiologically unsafe or of unknown water quality without adequate disinfection before or after the system.

**Find us here:**

[www.equip2clean.co.uk](http://www.equip2clean.co.uk)

Kiam House, Birchill Road,  
Knowsley Ind, Park North  
L33 7TD

0151 548 5500  
[contact@equip2clean.co.uk](mailto:contact@equip2clean.co.uk)