

**SV-250F** & *Long Ride*





## HOW TO USE THIS DOCUMENT ?

This master parts catalog lists and illustrates the assemblies, subassemblies and detail parts which comprise and are necessary for the support of the SY250F motorbike manufactured by Scorpa. This catalog is to be used to identify and order spare parts and components required for the SY250F support.

The applicability column, when used, indicates the limited applicability of parts to a specific motorbike model.

Item numbers on illustrations are used to cross-reference a specific item to a part number in the adjoining detailed parts list. Item numbers are arranged in numerical sequence in the fig. Item column of the detailed parts list.

## HOW TO ORDER PARTS?

To obtain informations regarding manufacturer guarantee, contact customer support service at the adress below.

Our customer support service is ready to assist you for all informations you may need ; For all spare parts order, contact your usual reseller or :

SCORPA SA  
Pôle mécanique  
30520 Saint Martin de Valgugues  
France

Tel : + 33 (0)4 66 54 36 11 (Spare parts)  
+ 33 (0)4 66 54 36 21 (Technical)  
Fax : + 33 (0)4 66 30 54 46  
e-mail : [service@scorpa.fr](mailto:service@scorpa.fr) (Spare parts)  
[consultant3@scorpa.fr](mailto:consultant3@scorpa.fr) (Technical)

## IMPORTANT NOTICES :

Scorpa recommends use of manufacturer originated parts only ; this required to ensure a correct and safe use of the motorbike. Use of other parts will cancel Scorpa liability in case of any damage.

This document does not contain contractual data. Updates can be issued at any time. This document contains Scorpa proprietary informations and data. It is delivered on the express condition that it is not to be disclosed or reproduced in whole or in parts without the written consent of Scorpa SA.

## TABLE OF CONTENTS

SUBJECT	FIG.	PAGE	REV.
CYLINDER	1	2	3
CYLINDER 2	1	4	3
CRANKSHAFT. PISTON	2	6	0
VALVE	3	8	0
VALVE 2	3	10	0
CAMSHAFT. CHAIN	4	12	0
WATER PUMP	5	14	0
OIL PUMP	6	16	0
OIL FILTER	7	18	0
CRANKASE	8	20	0
CRANKASE COVER	9	22	0
STARTER	10	24	0
CLUTCH	11	26	1
TRANSMISSION	12	28	0
SHIFT CAM . FORK	13	30	0
SHIFT SHAFT	14	32	0
GENERATOR	15	34	0
CARBURETTOR	16	36	3
FRAME	17	39	1
FORK	18	41	1
STEERING	19	43	1
REAR SUSPENSION	20	45	1
REAR ARM	21	47	1
AIR BOX	22	49	2
EXHAUST PIPE	23	51	1
MUFFLER	24	53	0
FUEL TANK	25	55	1
FUEL TANK LONG-RIDE	25 bis	57	0
RADIATOR	26	59	0
FRONT WHEEL	27	61	0
FRONT BRAKE	28	63	0
REAR WHEEL	29	65	3
REAR BRAKE	30	67	2
HANDLEBAR	31	69	1
FRONT MASTER CYLINDER	32	71	0
CLUTCH LEVER	33	73	0
REAR MASTER CYLINDER	34	75	0
STAND AND FOOTREST	35	77	1
STAND AND FOOTREST LONG-RIDE	35 bis	79	0
REAR LIGHT	36	81	2
HEAD LIGHT	37	83	1
HEAD LIGHT 125	38	85	1
ELECTRICAL WIRINGS	39	87	1
SPEEDOMETER	40	89	1
PLASTICS	41	91	1
PLASTICS LONG-RIDE	41 bis	93	0
STICKERS	42	95	0
STICKERS LONG-RIDE	42 bis	97	0



MOTEUR / ENGINE / MOTOR  
PARTLIST





FIG. 1 - CYLINDRE / CYLINDER / CILINDRO

N°	REF.	FRANÇAIS	ENGLISH	ESPAÑOL	QTY
1	5UM-11101-00-00	CULASSE ASSEMBLÉE	CYLINDER HEAD ASSY	CULATA	1
2	5NL-11133-10-00	GUIDE SOUPAPE 1	GUIDE, VALVE 1	GUÍA VÁLVULA 1	3
3	5NL-11134-10-00	GUIDE SOUPAPE 2	GUIDE, VALVE 2	GUÍA VÁLVULA 2	2
4	93440-10153-00	CIRCLIP	CIRCLIP	CIRCLIP	2
5	93440-07149-00	CIRCLIP	CIRCLIP	CIRCLIP	3
6	91808-16023-00	DOUILLE CENTRAGE	PIN, DOWEL	CENTRADOR	2
7	91808-16023-00	DOUILLE CENTRAGE	PIN, DOWEL	CENTRADOR	2
8	90105-06027-00	VIS EMBASE	SCREW, FLANGE	TORNILLO CON VALONA	10
9	90340-12112-00	BOUCHON	PLUG, STRAIGHT SCREW	TAPÓN	1
10	95022-06010-00	VIS EMBASE	SCREW, FLANGE	TORNILLO CON VALONA	1
11	90430-06014-00	JOINT	GASKET	JUNTA	1
12	90116-06541-00	GOUJON	SCREW, STUD	ESPÁRRAGO	2
13	95617-08620-00	GOUJON	SCREW, STUD	ESPÁRRAGO	1
14	95707-08500-00	ECROU EMBASE	NUT, FLANGE	TUERCA CON VALONA	1
15	94701-00411-00	BOUGIE (NGK R CR8E)	PLUG, SPARK (NGK R CR8E)	BUJÍA (NGK R CR8E)	1
	94701-00410-00	BOUGIE (NGK R CR9E)	PLUG, SPARK (NGK R CR9E)	BUJÍA (NGK R CR9E)	1
16	90340-12112-00	BOUCHON	PLUG, STRAIGHT SCREW	TAPÓN	1
17	5108-10804-00-00	OBTURATEUR	STOPPER, CYLINDER HEAD	OBTURADOR	1
18	5NL-11181-00-00	JOINT DE CULASSE	GASKET, CYLINDER HEAD	JUNTA CULATA	1
19	90105-09004-00	VIS EMBASE	SCREW, FLANGE	TORNILLO CON VALONA	2
20	90105-09002-00	VIS EMBASE	SCREW, FLANGE	TORNILLO CON VALONA	2
21	90201-096J9-00	RONDELLE	WASHER, PLATE	ARANDELA	4
22	5NL-11191-10-00	COUVRE CULASSE	COVER, CYLINDER HEAD	CUBRE CULATA	1
23	5BE-11167-00-00	EMBOU DURIT 1	NOZZLE, PIPE 1	CONTERA, TUBO 1	1
24	371-11167-01-00	EMBOU DURIT 2	NOZZLE, PIPE 2	CONTERA, TUBO 2	1
25	5TJ-11166-00-00	DURIT 1	PIPE 1	TUBO 1	1
26	90467-14015-00	CLIP	CLIP	CLIP	1
27	5XC-12481-90-00	COUDE D'EAU	BEND, WATER	CODO AGUA	1
28	93210-15566-00	JOINT TORIQUE	O-RING	TÓRICA	1
29	90467-14015-00	CLIP	CLIP	CLIP	1
30	5TA-11166-00-00	DURIT 2	PIPE 2	TUBO 2	1

LONG-RIDE

N°	REF.	FRANÇAIS	ENGLISH	ESPAÑOL	QTY
30	9DU10-07600-00	DURIT 2	PIPE 2	TUBO 2	1



1 - CYLINDRE / CYLINDER / CILINDRO

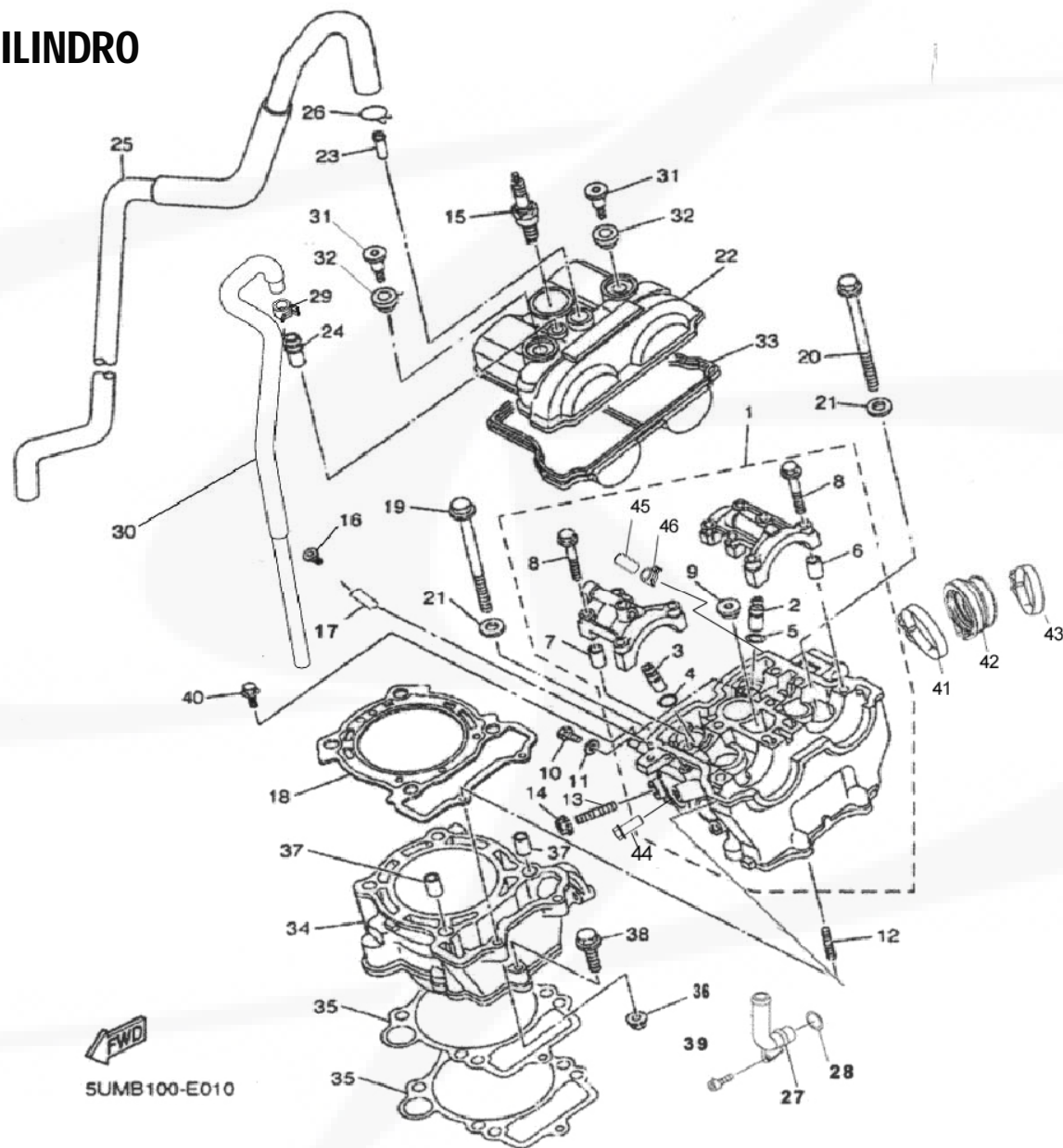



FIG. 1 - CYLINDRE / CYLINDER / CILINDRO

N°	REF.	FRANÇAIS	ENGLISH	ESPAÑOL	QTY
31	90109-066F0-00	VIS	SCREW	TORNILLO	2
32	4KG-1111G-00-00	CAOUTCHOUC	RUBBER	GOMA	2
33	5NL-11193-00-00	JOINT COUVRE CULASSE	GASKET, HEAD COVER	JUNTA CUBRE CULATA	1
34	5XC-11311-01-00	CYLINDRE	CYLINDER	CILINDRO	1
35	5NL-11351-00-00	JOINT EMBASE	GASKET, CYLINDER	JUNTA CILINDRO	2
36	95702-06500-00	ECROU EMBASE	NUT, FLANGE	TUERCA CON VALONA	2
37	93612-16254-00	DOUILLE CENTRAGE	PIN, DOWEL	CENTRADOR	2
38	95022-06035-00	VIS EMBASE	SCREW, FLANGE	TORNILLO CON VALONA	1
39	95027-06012-00	VIS EMBASE	SCREW, FLANGE	TORNILLO CON VALONA	1
40	95827-06014-00	VIS EMBASE	SCREW, FLANGE	TORNILLO CON VALONA	1
41	90450-47001-00	COLLIER MANCHON	HOSE CLAMP	BRIDA TOBERA	1
42	S10B-10701-00-00	PIPE ADMISSION	HOSE	TOBERA ADMISIÓN	1
43	90450-54002-00	COLLIER MANCHON	HOSE CLAMP	BRIDA TOBERA	1
44	95817-08020-00	VIS ATTACHE TUBE ÉCHAPPEMENT	SCREW, EXHAUST PIPE ATTACHING	TORNILLO FIJACIÓN TUBO ESCAPE	1

LONG-RIDE

N°	REF.	FRANÇAIS	ENGLISH	ESPAÑOL	QTY
45	16G-13569-00-00	OBTURATEUR ANTI-DÉPRESSION	STOPPER, CYLINDER HEAD ANTI-DEPRESSION	OBTURADOR ANTI-DEPRESIÓN	1
46	90467-11106-00	CLIP	CLIP	CLIP	1



## 2 – VILEBREQUIN ET PISTON / CRANKSHAFT AND PISTON / CIGÜEÑAL Y PISTÓN

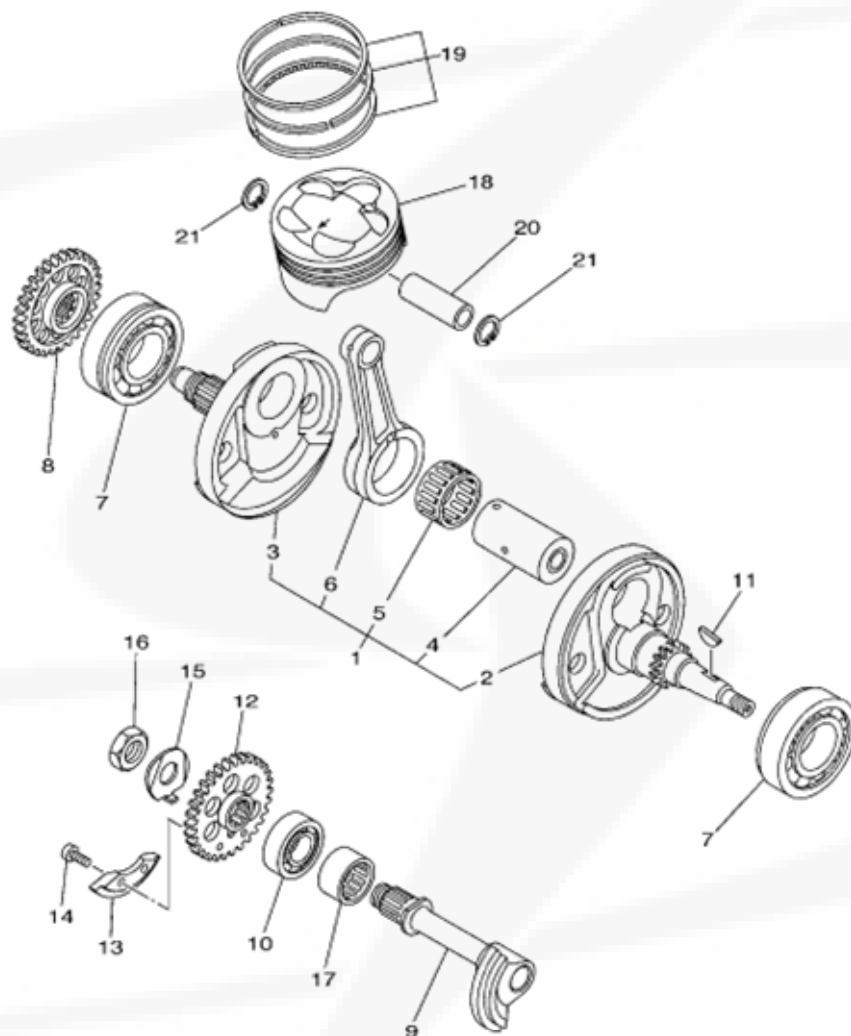

  
5NL1100-1020



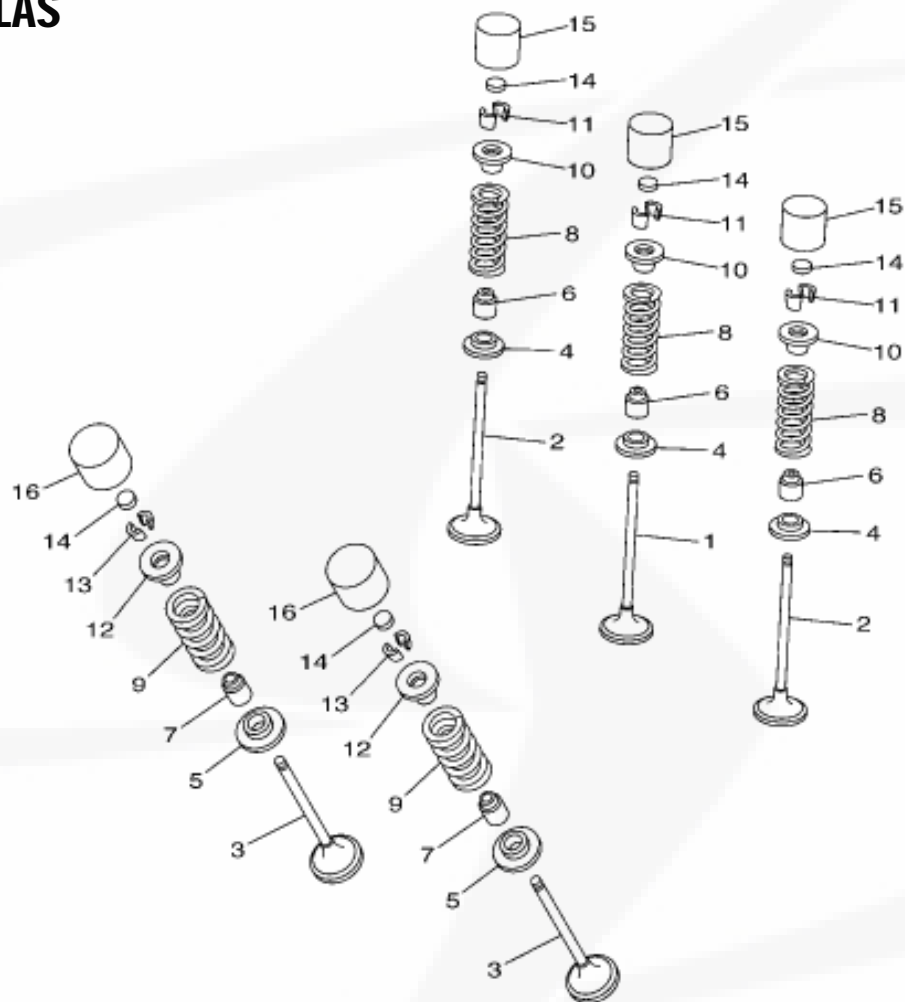

FIG. 2 - VILEBREQUIN ET PISTON / CRANKSHAFT AND PISTON / CIGÜEÑAL Y PISTÓN

N°	REF.	FRANÇAIS	ENGLISH	ESPAÑOL	QTY
1	5UM-11400-20-00	VILEBREQUIN COMPLET	CRANKSHAFT ASSY	CIGÜEÑAL	1
2	5UM-11412-10-00	MASSE 1	CRANK 1	MASA 1	1
3	5UL-11422-00-00	MASSE 2	CRANK 2	MASA 2	1
4	5UL-11681-00-00	MANETON	PIN, CRANK	MUÑEQUILLA	1
5	93310-63238-00	ROULEMENT	BEARING	COJINETE	1
6	5UL-11651-00-00	BIELLE	ROD, CONNECTING	BIELA	1
7	93306-20648-00	ROULEMENT	BEARING	COJINETE	2
8	5NL-11536-00-00	PIGNON VILEBREQUIN	GEAR, DRIVE	PIÑÓN CIGÜEÑAL	1
9	5NL-11455-00-00	ARBRE BALANCIER D'ÉQUILIBRAGE	SHAFT	EJE EQUILIBRA	1
10	93306-20335-00	ROULEMENT	BEARING	COJINETE	1
11	90280-03006-00	CLAVETTE	KEY, WOODRUFF	CHAVETA	1
12	5NL-11531-00-00	PIGNON BALANCIER	GEAR, BALANCE WEIGHT	PIÑÓN BALANCÍN	1
13	5NL-11454-00-00	POIDS	WEIGHT	PESO	1
14	90149-06250-00	VIS	SCREW	TORNILLO	2
15	90215-14204-00	RONDELLE FREIN	WASHER, LOCK	ARANDELA FRENO	1
16	90170-14171-00	ECROU	NUT	TUERCA	1
17	93311-32261-00	ROULEMENT	BEARING	COJINETE	1
18	5NL-11631-20-00	PISTON	PISTON (STD)	PISTÓN	1
19	5NL-11603-00-00	SEGMENTS	PISTON RING SET (STD)	AROS	1
20	5NL-11633-00-00	AXE DE PISTON	PIN, PISTON	BULÓN PISTÓN	1
21	93420-16086-00	CIRCLIP	CIRCLIP	CIRCLIP	2



### 3 – SOUPAPES / VALVE / VÁLVULAS



5NL1100-1030

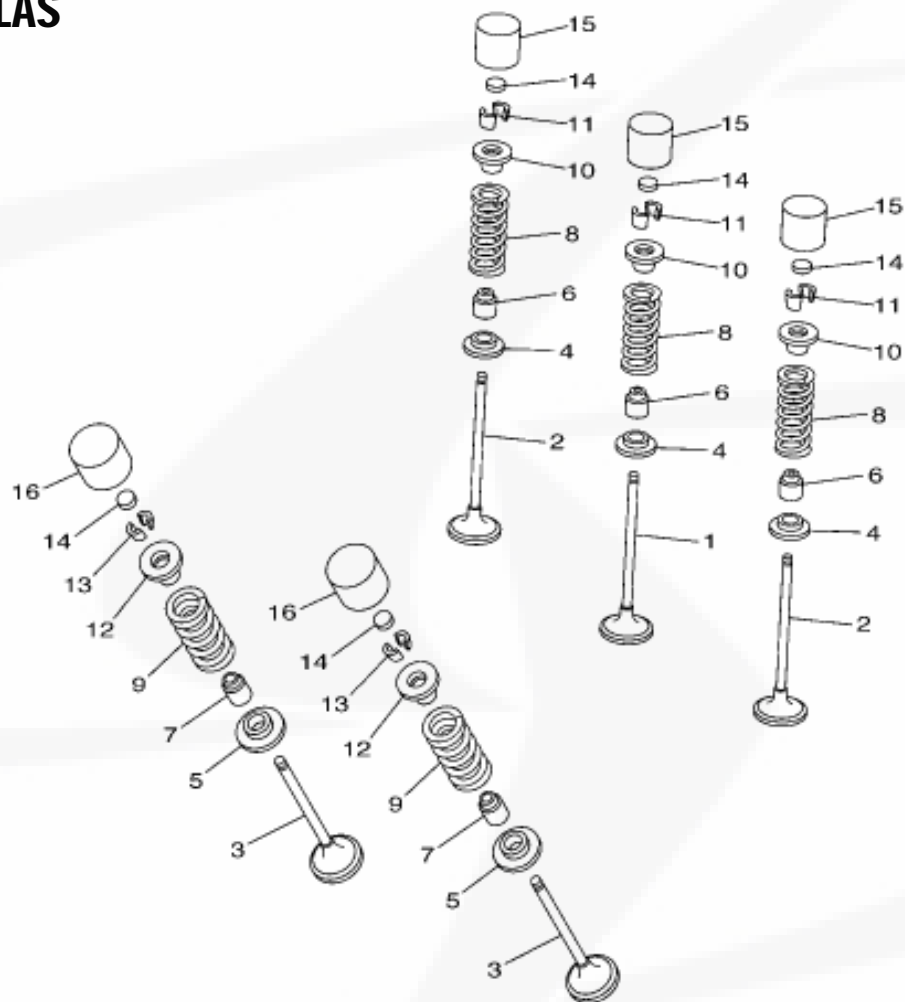

FIG. 3 - SOUPAPES / VALVE / VÁLVULAS

N°	REF.	FRAÇAIS	ENGLISH	ESPAÑOL	QTY
1	5NL-12111-10-00	SOUPAPE D'ADMISSION 1	VALVE, INTAKE 1	VÁLVULA ADMISIÓN 1	1
2	5NL-12112-10-00	SOUPAPE D'ADMISSION 2	VALVE, INTAKE 2	VÁLVULA ADMISIÓN 2	2
3	5NL-12121-10-00	SOUPAPE D'ÉCHAPPEMENT	VALVE, EXHAUST	VÁLVULA ESCAPE	2
4	5NL-12116-00-00	SIÈGE RESSORT DE SOUPAPE 1	SEAT, VALVE SPRING 1	ARANDELA MUELLE VÁLVULA 1	3
5	3GM-12126-00-00	SIÈGE RESSORT DE SOUPAPE 2	SEAT, VALVE SPRING 2	ARANDELA MUELLE VÁLVULA 2	2
6	4TV-12119-00-00	JOINT TIGE DE SOUPAPE 1	SEAL, VALVE STEM 1	RETÉN VÁLVULA 1	3
7	4SV-12119-00-00	JOINT TIGE DE SOUPAPE 2	SEAL, VALVE STEM 2	RETÉN VÁLVULA 2	2
8	5NL-12113-00-00	RESSORT SOUPAPE ADMISSION	SPRING, VALVE INNER	MUELLE VÁLVULA ADMISIÓN	3
9	5NL-12114-00-00	RESSORT SOUPAPE ÉCHAPPEMENT	SPRING, VALVE OUTER	MUELLE VÁLVULA ESCAPE	2
10	1HX-12117-00-00	COUPELLE RESSORT DE SOUPAPE 1	COTTER, VALVE 1	SOMBRERETE VÁLVULA 1	3
11	1HX-12118-00-00	DEMI CÔNES 1	RETAINER, VALVE SPRING 1	SEMICONO VÁLVULA 1	6
12	1WG-12117-00-00	COUPELLE RESSORT DE SOUPAPE 2	COTTER, VALVE 2	SOMBRERETE VÁLVULA 2	2
13	1WG-12118-00-00	DEMI CÔNES 2	RETAINER, VALVE SPRING 2	SEMICONO VÁLVULA 2	4
14	1HX-12168-00-00	PASTILLE DE RÉGLAGE (1.20)	PAD, ADJUSTING (1.20)	PASTILLA REGLAJE (1.20)	5
	1HX-12168-20-00	PASTILLE DE RÉGLAGE (1.25)	PAD, ADJUSTING (1.25)	PASTILLA REGLAJE (1.25)	5
	1HX-12168-40-00	PASTILLE DE RÉGLAGE (1.30)	PAD, ADJUSTING (1.30)	PASTILLA REGLAJE (1.30)	5
	1HX-12168-60-00	PASTILLE DE RÉGLAGE (1.35)	PAD, ADJUSTING (1.35)	PASTILLA REGLAJE (1.35)	5
	1HX-12168-80-00	PASTILLE DE RÉGLAGE (1.40)	PAD, ADJUSTING (1.40)	PASTILLA REGLAJE (1.40)	5
	1HX-12168-A0-00	PASTILLE DE RÉGLAGE (1.45)	PAD, ADJUSTING (1.45)	PASTILLA REGLAJE (1.45)	5
	1HX-12168-F0-00	PASTILLE DE RÉGLAGE (1.50)	PAD, ADJUSTING (1.50)	PASTILLA REGLAJE (1.50)	5
	1HX-12168-H1-00	PASTILLE DE RÉGLAGE (1.55)	PAD, ADJUSTING (1.55)	PASTILLA REGLAJE (1.55)	5
	1HX-12168-K1-00	PASTILLE DE RÉGLAGE (1.60)	PAD, ADJUSTING (1.60)	PASTILLA REGLAJE (1.60)	5
	1HX-12168-M1-00	PASTILLE DE RÉGLAGE (1.65)	PAD, ADJUSTING (1.65)	PASTILLA REGLAJE (1.65)	5
	1HX-12168-R1-00	PASTILLE DE RÉGLAGE (1.70)	PAD, ADJUSTING (1.70)	PASTILLA REGLAJE (1.70)	5
	1HX-12168-U1-00	PASTILLE DE RÉGLAGE (1.75)	PAD, ADJUSTING (1.75)	PASTILLA REGLAJE (1.75)	5
	1HX-12168-W1-00	PASTILLE DE RÉGLAGE (1.80)	PAD, ADJUSTING (1.80)	PASTILLA REGLAJE (1.80)	5
	1HX-12168-Y1-00	PASTILLE DE RÉGLAGE (1.85)	PAD, ADJUSTING (1.85)	PASTILLA REGLAJE (1.85)	5



### 3 – SOUPAPES / VALVE / VÁLVULAS



5NL1100-1030

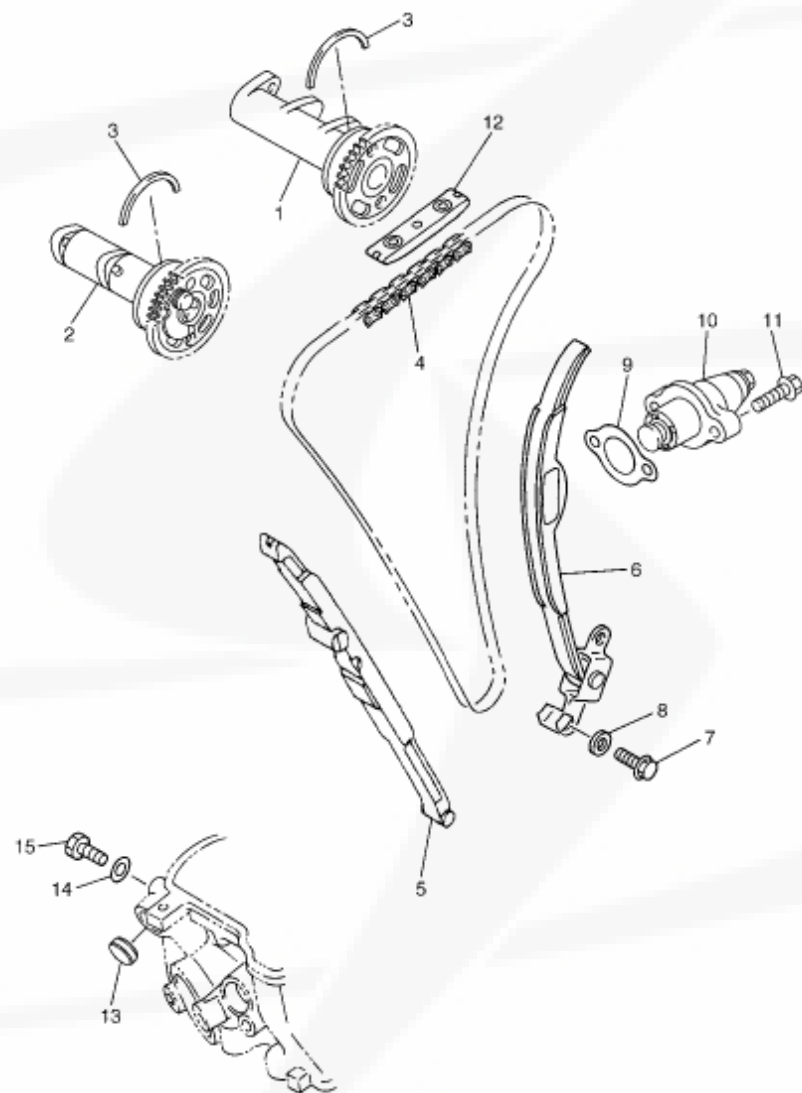

FIG. 3 - SOUPAPES / VALVE / VÁLVULAS

N°	REF.	FRANÇAIS	ENGLISH	ESPAÑOL	QTY
14	1HX-12169-11-00	PASTILLE DE RÉGLAGE (1.90)	PAD, ADJUSTING (1.90)	PASTILLA REGLAJE (1.90)	5
	1HX-12169-31-00	PASTILLE DE RÉGLAGE (1.95)	PAD, ADJUSTING (1.95)	PASTILLA REGLAJE (1.95)	5
	1HX-12169-50-00	PASTILLE DE RÉGLAGE (2.00)	PAD, ADJUSTING (2.00)	PASTILLA REGLAJE (2.00)	5
	1HX-12169-70-00	PASTILLE DE RÉGLAGE (2.05)	PAD, ADJUSTING (2.05)	PASTILLA REGLAJE (2.05)	5
	1HX-12169-90-00	PASTILLE DE RÉGLAGE (2.10)	PAD, ADJUSTING (2.10)	PASTILLA REGLAJE (2.10)	5
	1HX-12169-E0-00	PASTILLE DE RÉGLAGE (2.15)	PAD, ADJUSTING (2.15)	PASTILLA REGLAJE (2.15)	5
	1HX-12169-G0-00	PASTILLE DE RÉGLAGE (2.20)	PAD, ADJUSTING (2.20)	PASTILLA REGLAJE (2.20)	5
	1HX-12169-J0-00	PASTILLE DE RÉGLAGE (2.25)	PAD, ADJUSTING (2.25)	PASTILLA REGLAJE (2.25)	5
	1HX-12169-L0-00	PASTILLE DE RÉGLAGE (2.30)	PAD, ADJUSTING (2.30)	PASTILLA REGLAJE (2.30)	5
	1HX-12169-N0-00	PASTILLE DE RÉGLAGE (2.35)	PAD, ADJUSTING (2.35)	PASTILLA REGLAJE (2.35)	5
1HX-12169-T0-00	PASTILLE DE RÉGLAGE (2.40)	PAD, ADJUSTING (2.40)	PASTILLA REGLAJE (2.40)	5	
15	3NL-12153-00-00	POUSSOIR SOUPAPE ADMISSION	TAPPET, VALVE	VASO EMPUJADOR VÁLVULA	3
	3NL-12153-10-00	POUSSOIR SOUPAPE ADMISSION	TAPPET, VALVE	VASO EMPUJADOR VÁLVULA	3
	3NL-12153-20-00	POUSSOIR SOUPAPE ADMISSION	TAPPET, VALVE	VASO EMPUJADOR VÁLVULA	3
	3NL-12153-30-00	POUSSOIR SOUPAPE ADMISSION	TAPPET, VALVE	VASO EMPUJADOR VÁLVULA	3
16	3FV-12153-00-00	POUSSOIR SOUPAPE ÉCHAPPEMENT	TAPPET, VALVE	VASO EMPUJADOR VÁLVULA	3
	3FV-12153-10-00	POUSSOIR SOUPAPE ÉCHAPPEMENT	TAPPET, VALVE	VASO EMPUJADOR VÁLVULA	3
	3FV-12153-20-00	POUSSOIR SOUPAPE ÉCHAPPEMENT	TAPPET, VALVE	VASO EMPUJADOR VÁLVULA	3
	3FV-12153-30-00	POUSSOIR SOUPAPE ÉCHAPPEMENT	TAPPET, VALVE	VASO EMPUJADOR VÁLVULA	3



## 4 – DISTRIBUTION / CAMSHAFT AND CHAIN / DISTRIBUCIÓN



5UL1100-B040



FIG. 4 - DISTRIBUTION / CAMSHAFT AND CHAIN / DISTRIBUCIÓN

N°	REF.	FRANÇAIS	ENGLISH	ESPAÑOL	QTY
1	S10D-10202-00-00	ARBRE À CAMES ADMISSION	CAMSHAFT ASSY, INTAKE	ÁRBOL DE LEVAS ADMISIÓN	1
2	5UM-12180-10-00	ARBRE À CAMES ÉCHAPPEMENT	CAMSHAFT ASSY, EXHAUST	ÁRBOL DE LEVAS ESCAPE	1
3	93440-41178-00	CIRCLIP	CIRCLIP	CIRCLIP	2
4	94591-53114-00	CHAÎNE	CHAIN	CADENA	1
5	5NL-12251-10-00	GUIDE CHAÎNE 1	GUIDE, CHAIN 1	GUÍA CADENA 1	1
6	5NL-12252-00-00	GUIDE CHAÎNE 2	GUIDE, CHAIN 2	GUÍA CADENA 2	1
7	97027-06016-00	VIS	SCREW	TORNILLO	2
8	92907-06600-00	RONDILLE	WASHER, PLATE	ARANDELA	2
9	4FM-12213-00-00	JOINT TENDEUR CHAÎNE	GASKET, TENSION ADJUSTER	JUNTA TENSOR CADENA	1
10	5TA-12210-00-00	TENDEUR CHAÎNE DE DISTRIBUTION	TENSION ADJUSTER, CAM CHAIN	TENSOR CADENA DE DISTRIBUCIÓN	1
11	95027-06025-00	VIS EMBASE	SCREW, FLANGE	TORNILLO CON VALONA	2
12	5BE-12241-00-00	GUIDE CHAÎNE 3	GUIDE, CHAIN 3	GUÍA CADENA 3	1
13	90338-18064-00	BOUCHON	PLUG	TAPÓN	1
14	90430-06014-00	JOINT	GASKET	JUNTA	1
15	90109-06418-00	VIS	SCREW	TORNILLO	1



## 5 – POMPE A EAU / WATER PUMP / BOMBA DE AGUA

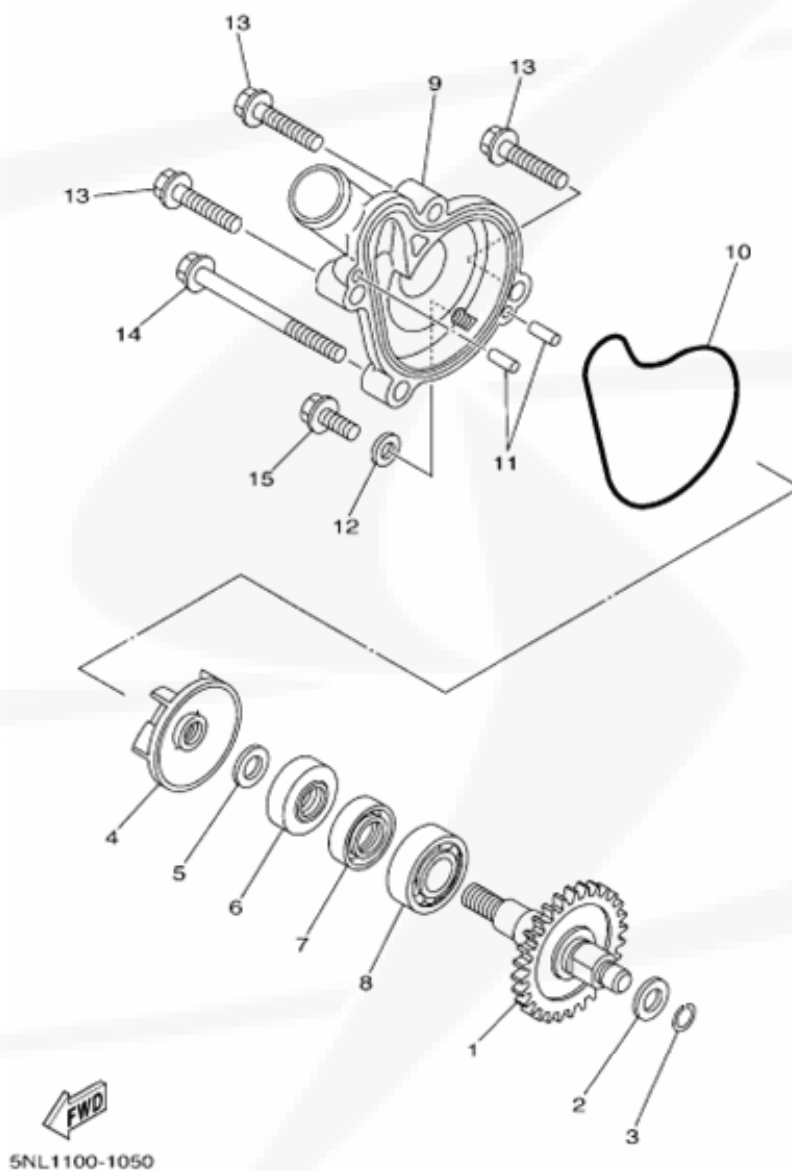



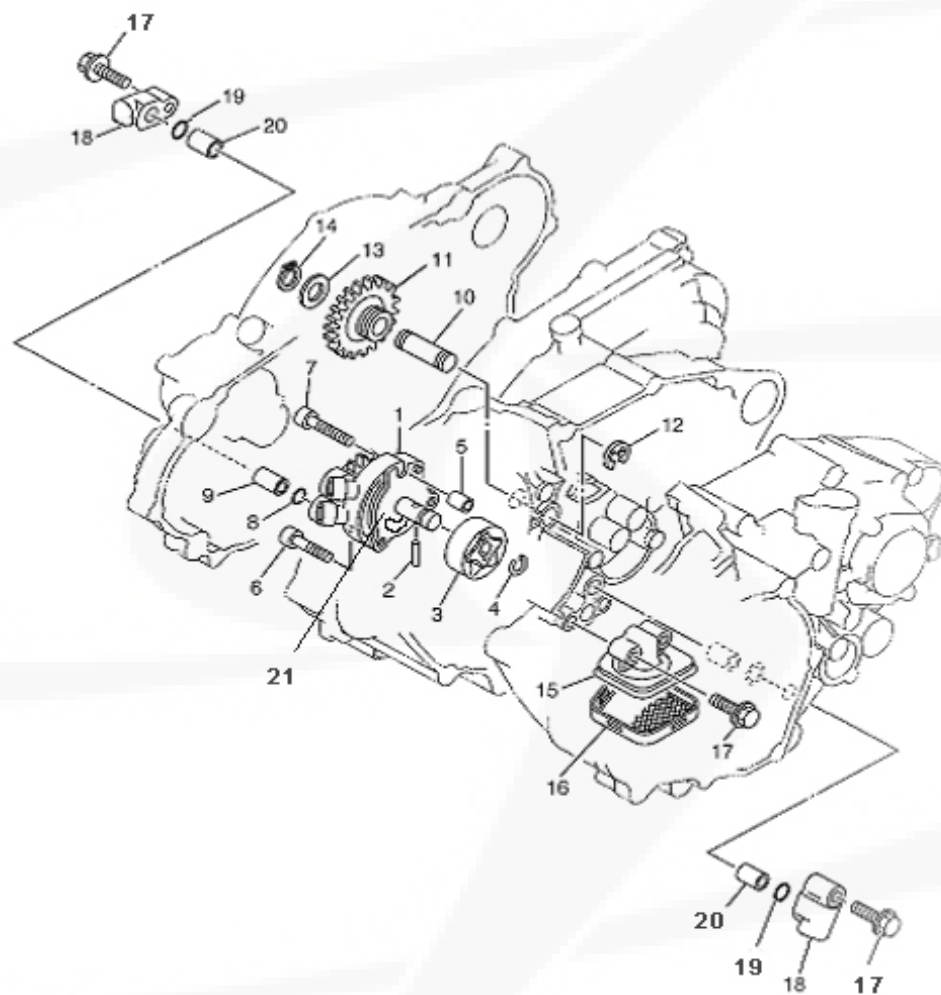

FIG. 5 – POMPE À EAU / WATER PUMP / BOMBA DE AGUA

N°	REF.	FRANÇAIS	ENGLISH	ESPAÑOL	QTY
1	5XC-12459-00-00	PIGNON TURBINE	GEAR, IMPELLER SHAFT	PIÑÓN TURBINA	1
2	90201-08512-00	RONDELLE	WASHER, PLATE	ARANDELA	1
3	93440-07182-00	CIRCLIP	CIRCLIP	CIRCLIP	1
4	5DH-12451-00-00	TURBINE POMPE À EAU	IMPELLER, WATER PUMP	TURBINA BOMBA AGUA	1
5	90201-08512-00	RONDELLE	WASHER, PLATE	ARANDELA	1
6	93109-11073-00	JOINT D'ÉTANCHÉITÉ	OIL SEAL	JUNTA ESTANQUEIDAD	1
7	93102-12106-00	JOINT D'ÉTANCHÉITÉ (SD 12-22-5HS)	OIL SEAL (SD 12-22-5HS)	JUNTA ESTANQUEIDAD (SD 12-22-5HS)	1
8	93306-00105-00	ROULEMENT (B6001)	BEARING (B6001)	COJINETE (B6001)	1
9	5NL-12422-10-00	COUVERCLE POMPE À EAU	COVER, HOUSING	TAPA BOMBA AGUA	1
10	5NL-12439-00-00	JOINT TORIQUE	O-RING	TÓRICA	1
11	93604-10011-00	DOUVILLE CENTRAGE	PIN, DOWEL	CENTRADOR	2
12	90430-06014-00	JOINT	GASKET	JUNTA	1
13	95022-06025-00	VIS EMBASE	SCREW, FLANGE	TORNILLO CON VALONA	3
14	95022-06065-00	VIS EMBASE	SCREW, FLANGE	TORNILLO CON VALONA	1
15	95022-06012-00	VIS EMBASE	SCREW, FLANGE	TORNILLO CON VALONA	1



## 6 – POMPE A HUILE / OIL PUMP / BOMBA DE ACEITE



5UL1100-B070

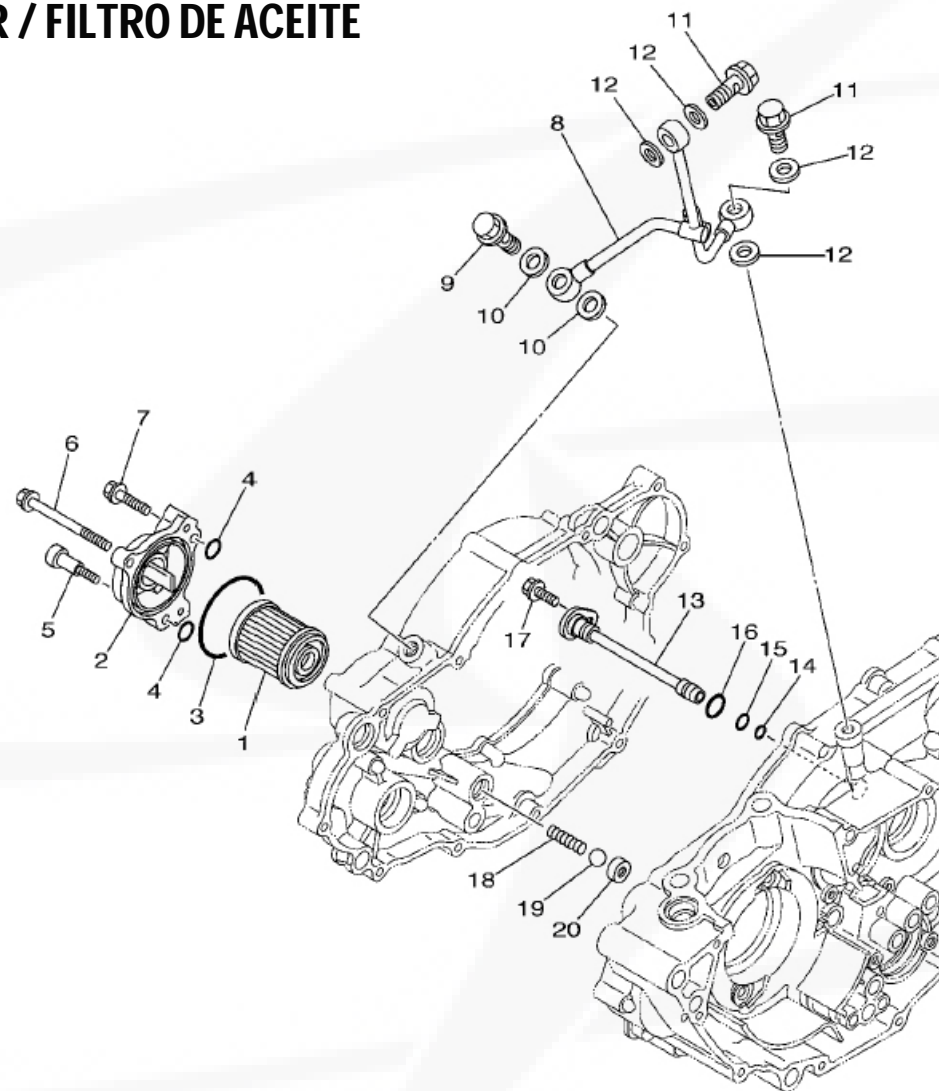

FIG. 6 – POMPE À HUILE / OIL PUMP / BOMBA DE ACEITE

N°	REF.	FRANÇAIS	ENGLISH	ESPAÑOL	QTY
1	5SG-13300-00-00	POMPE À HUILE	OIL PUMP ASSY	BOMBA DE ACEITE	1
2	93603-16219-00	DOUILLE CENTRAGE	PIN, DOWEL	CENTRADOR	1
3	5NL-13320-00-00	ROTORS	ROTOR ASSY	ROTOR	1
4	93440-10153-00	CIRCLIP	CIRCLIP	CIRCLIP	1
5	99530-08012-00	DOUILLE CENTRAGE	PIN, DOWEL	CENTRADOR	1
6	91312-06025-00	VIS	SCREW	TORNILLO	2
7	91317-06030-00	VIS	SCREW	TORNILLO	1
8	93210-10197-00	JOINT TORIQUE	O-RING	TÓRICO	1
9	99530-10114-00	DOUILLE CENTRAGE	PIN, DOWEL	CENTRADOR	1
10	5BE-13342-00-00	ARBRE POMPE À HUILE	SHAFT, IDLE GEAR	EJE BOMBA ACEITE	1
11	5NL-13341-00-00	PIGNON POMPE À HUILE	GEAR, OIL PUMP IDLE	PIÑÓN	1
12	99001-08600-00	CIRCLIP	CIRCLIP	CIRCLIP	1
13	90201-12166-00	RONDELLE	WASHER, PLATE	ARANDELA	1
14	99009-12400-00	CIRCLIP	CIRCLIP	CIRCLIP	1
15	5NL-13412-00-00	CACHE FILTRE À HUILE	HOUSING, STRAINER	TAPA FILTRO ACEITE	1
16	5NL-13411-00-00	FILTRE À HUILE	STRAINER, OIL	FILTRO ACEITE	1
17	95022-06025-00	VIS EMBASE	SCREW, FLANGE	TORNILLA CON VALONA	4
18	S10B-10903-00-00	OBTURATEUR HUILE	OIL STOPPER	OBTURADOR ACEITE	2
19	93210-10197-00	JOINT TORIQUE	O-RING	TÓRICO	2
20	99530-10114-00	DOUILLE CENTRAGE	PIN, DOWEL	CENTRADOR	2
21	S10B-10500-00-00	CLOISON POMPE À HUILE	OIL PUMP SHEET	PARED BOMBA ACEITE	1



## 7 – FILTRE A HUILE / OIL FILTER / FILTRO DE ACEITE



5NL1100-1080

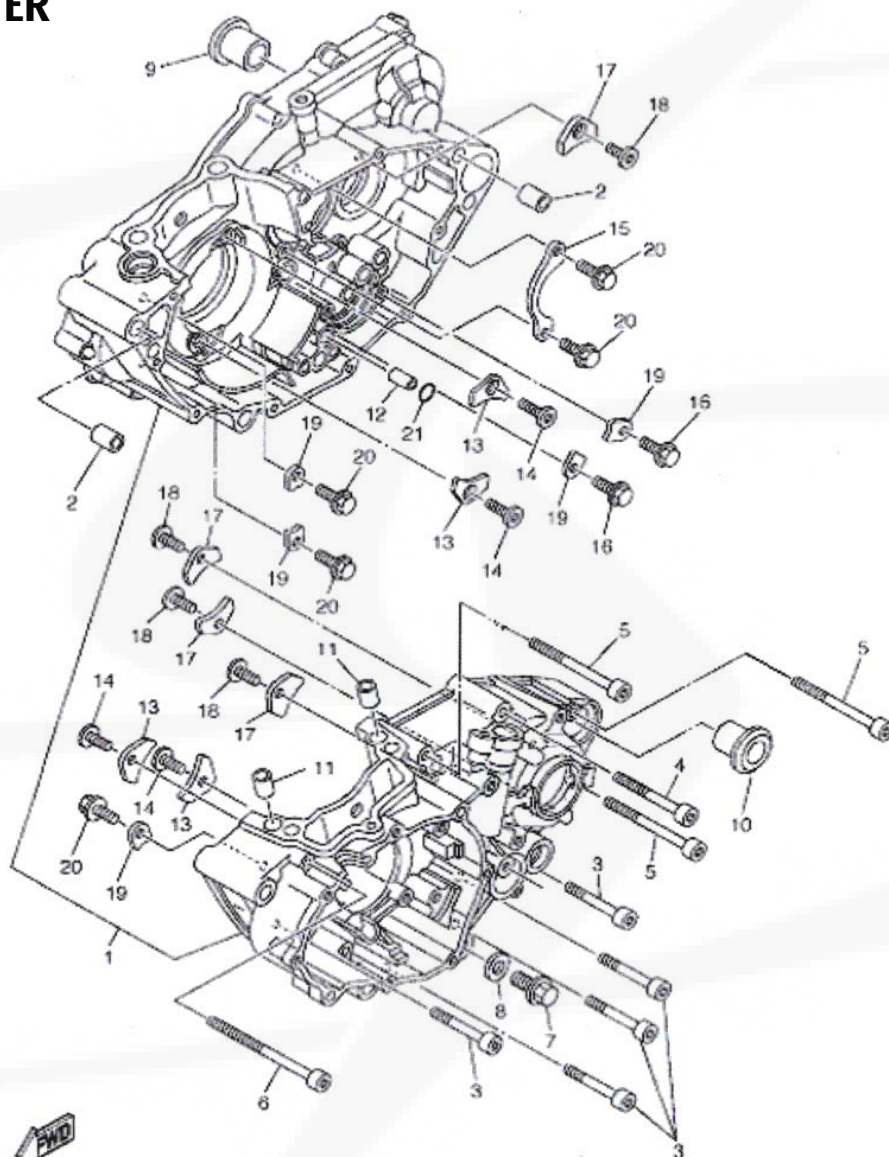

FIG. 7 – FILTRE À HUILE / OIL FILTER / FILTRO ACEITE

N°	REF.	FRANÇAIS	ENGLISH	ESPAÑOL	QTY
1	5TA-13440-00-00	FILTRE À HUILE	ELEMENT ASSY, OIL FILTER	FILTRO DE ACEITE	1
2	5BE-13447-10-00	COUVERCLE FILTRE À HUILE	COVER, OIL ELEMENT	TAPA FILTRO DE ACEITE	1
3	93210-47675-00	JOINT TORIQUE	O-RING	TÓRICA	1
4	93210-07135-00	JOINT TORIQUE	O-RING	TÓRICA	3
5	90110-06228-00	VIS	SCREW	TORNILLO	1
6	91312-06065-00	VIS EMBASE	SCREW, FLANGE	TORNILLO CON VALONA	1
7	91312-06025-00	VIS EMBASE	SCREW, FLANGE	TORNILLO CON VALONA	1
8	5NL-13161-10-00	TUBE DISTRIBUTION HUILE 1	PIPE, DELIVERY 1	TUBO DISTRIBUIDOR ACEITE 1	1
9	90401-10015-00	VIS RACCORD	SCREW, UNION	TORNILLO CONEXIÓN	1
10	90430-10188-00	JOINT	GASKET	JUNTA	2
11	90401-08006-00	VIS RACCORD	SCREW, UNION	TORNILLO CONEXIÓN	2
12	90430-08119-00	JOINT	GASKET	JUNTA	4
13	5NL-13171-00-00	TUBE DISTRIBUTION HUILE 2	PIPE, DELIVERY 2	TUBO DISTRIBUIDOR ACEITE 2	1
14	93210-07003-00	JOINT TORIQUE	O-RING	TÓRICA	1
15	93210-09008-00	JOINT TORIQUE	O-RING	TÓRICA	1
16	93210-12759-00	JOINT TORIQUE	O-RING	TÓRICA	1
17	95027-06012-00	VIS EMBASE	SCREW, FLANGE	TORNILLO CON VALONA	1
18	90501-043E0-00	RESSORT COMPRESSION	SPRING, COMPRESSION	MUELLE APRETADOR	1
19	93503-08007-00	BILLE	BALL	BOLA	1
20	583-13113-00-00	SIÈGE BILLE	SEAT, CHECK BALL	ARANDELA BOLA	1



## 8 - CARTER / CRANKCASE / CARTER



SUM1100-B120



FIG. 8 - CARTER / CRANKCASE / CÁRTER

N°	REF.	FRANÇAIS	ENGLISH	ESPAÑOL	QTY
1	5UM-15150-10-00	CARTER	CRANKCASE ASSY	CÁRTER	1
2	93612-16254-00	DOUILLE CENTRAGE	PIN, DOWEL	CENTRADOR	2
3	91312-06045-00	VIS	SCREW	TORNILLO	5
4	91312-06055-00	VIS	SCREW	TORNILLO	1
5	91312-06070-00	VIS	SCREW	TORNILLO	3
6	91312-06100-00	VIS	SCREW	TORNILLO	1
7	95022-10016-00	VIS EMBASE	SCREW, FLANGE	TORNILLO VON VALONA	1
8	90430-10188-00	JOINT	GASKET	JUNTA	1
9	9E018-14032-24	ENTRETOISE DROITE	COLLAR RIGHT	CASQUILLO DERECHO	1
10	9E032-14032-24	ENTRETOISE GAUCHE	COLLAR LEFT	CASQUILLO IZQUIERDO	1
11	99530-10116-00	DOUILLE CENTRAGE	PIN, DOWEL	CENTRADOR	2
12	99530-10114-00	DOUILLE CENTRAGE	PIN, DOWEL	CENTRADOR	1
13	5BE-15383-01-00	PLAQUE PROTECTION ROULEMENT	PLATE, BEARING COVER	TAPA PROTECCIÓN COJINETE	4
14	90149-06126-00	VIS	SCREW	TORNILLO	4
15	5NL-15388-00-00	PLAQUE PROTECTION ROULEMENT	PLATE, BEARING COVER	TAPA PROTECCIÓN COJINETE	1
16	90105-06553-00	VIS EMBASE	SCREW, FLANGE	TORNILLO CON VALONA	2
17	4JT-15381-01-00	PLAQUE PROTECTION ROULEMENT	PLATE, BEARING COVER	TAPA PROTECCIÓN COJINETE	4
18	90149-06326-00	VIS	SCREW	TORNILLO	4
19	5DH-18562-00-00	PLAQUE OBTURATION	PLATE, STOPPER	TAPA OBTURACIÓN	5
20	90105-06553-00	VIS EMBASE	SCREW, FLANGE	TORNILLO CON VALONA	5
21	93210-10197-00	JOINT TORIQUE	O-RING	TÓRICA	1



## 9 – COUVRE CARTERS / CRANKCASE COVER / CUBRE CARTER

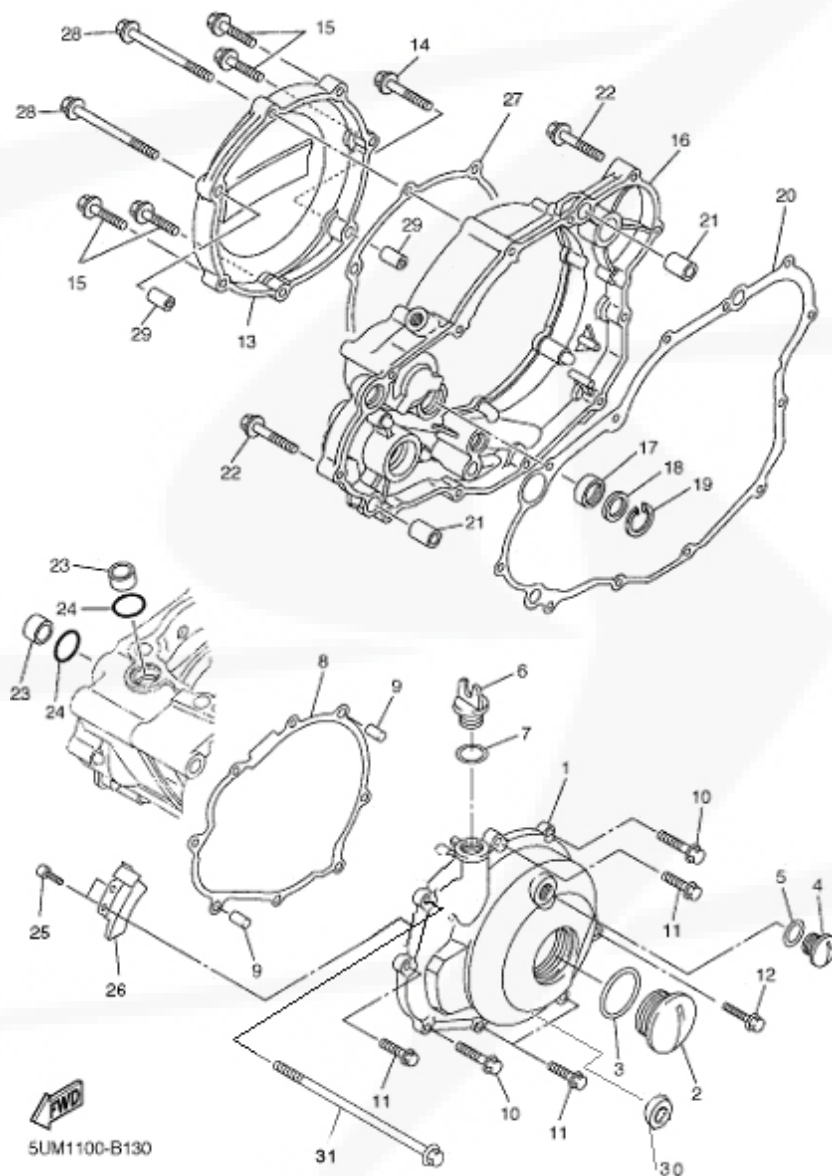



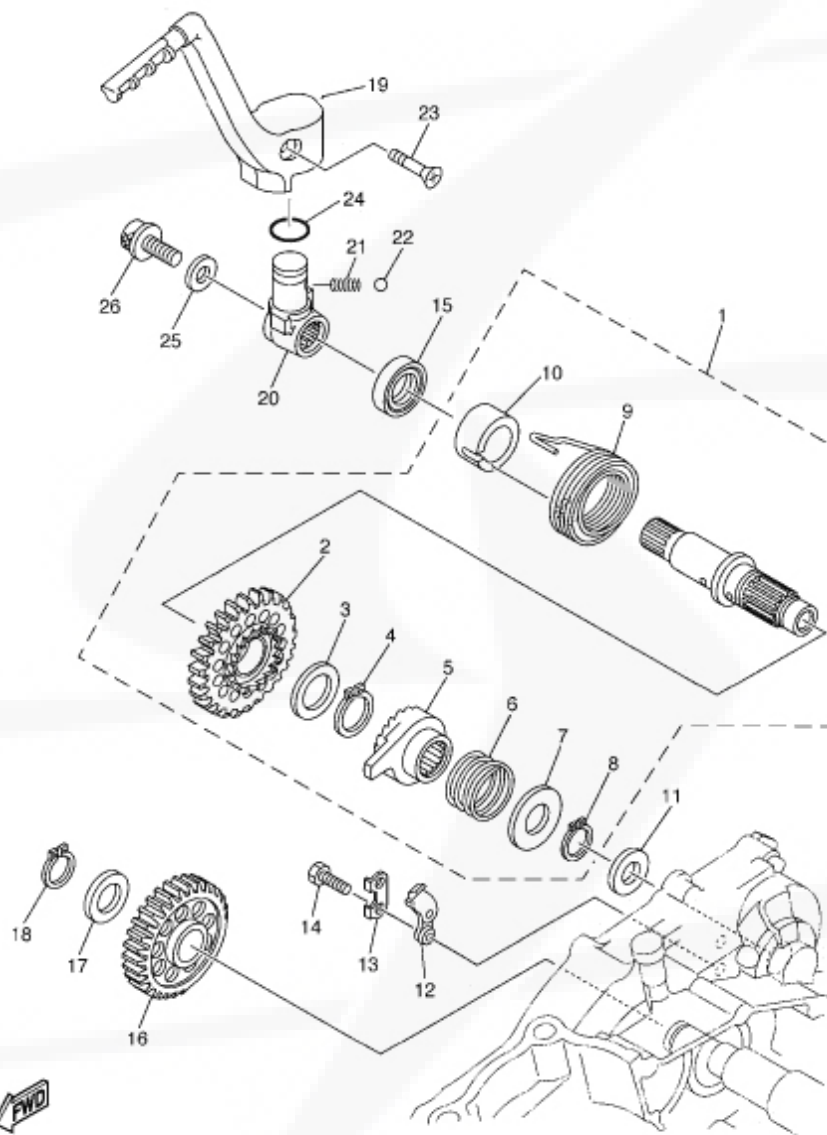

FIG. 9 - COUVRE CARTERS / CRANKCASE COVER / CUBRE CÁRTER

N°	REF.	FRANÇAIS	ENGLISH	ESPAÑOL	QTY
1	S108-10902-00-00	COUVRE CARTER 1	COVER, CRANKCASE 1	CUBRE CÁRTER 1	1
2	90340-27002-00	BOUCHON	PLUG, STRAIGHT SCREW	TAPÓN	1
3	93210-27370-00	JOINT TORIQUE	O-RING	TÓRICA	1
4	90340-14128-00	BOUCHON	PLUG, STRAIGHT SCREW	TAPÓN	1
5	93210-14369-00	JOINT TORIQUE	O-RING	TÓRICA	1
6	3Y1-15363-00-00	BOUCHON HUILE	PLUG, OIL	TAPÓN ACEITE	1
7	93210-19123-00	JOINT TORIQUE	O-RING	TÓRICA	1
8	SUM-15451-00-00	JOINT COUVRE CARTER 1	GASKET, CRANKCASE COVER 1	JUNTA CUBRE CÁRTER 1	1
9	99530-08016-00	DOUILLE CENTRAGE	PIN, DOWEL	CENTRADOR	2
10	95022-06040-00	VIS EMBASE	SCREW, FLANGE	TORNILLO CON VALONA	2
11	95022-06030-00	VIS EMBASE	SCREW, FLANGE	TORNILLO CON VALONA	4
12	91312-06110-00	VIS	SCREW	TORNILLO	1
13	SUM-15498-10-00	COUVRE CARTER 2	COVER, CRANKCASE 2	CUBRE CÁRTER 1	1
14	95022-06035-00	VIS EMBASE	SCREW, FLANGE	TORNILLO CON VALONA	1
15	95022-06025-00	VIS EMBASE	SCREW, FLANGE	TORNILLO CON VALONA	4
16	5NL-15431-10-00	CARTER	CRANKCASE	CÁRTER	1
17	93101-14164-00	JOINT D'ÉTANCHÉITÉ	OIL SEAL	JUNTA ESTANQUEIDAD	1
18	90201-15701-00	RONDELLE	WASHER, PLATE (T=1.0)	ARANDELA	1
19	99009-22500-00	CIRCLIP	CIRCLIP	CIRCLIP	1
20	5NL-15462-00-00	JOINT CARTER	GASKET, CRANKCASE	JUNTA CÁRTER	1
21	91812-16001-00	DOUILLE CENTRAGE	PIN, DOWEL	CENTRADOR	2
22	95022-06035-00	VIS EMBASE	SCREW, FLANGE	TORNILLO CON VALONA	8
23	5NL-12564-00-00	ENTRETOISE	PIPE, WATER	CASQUILLO	2
24	93210-16716-00	JOINT TORIQUE	O-RING	TÓRICA	2
25	91317-05012-00	VIS	SCREW	TORNILLO	1
26	SUM-81528-00-00	BRIDE	CLAMP	BRIDA	1
27	5NL-15453-00-00	JOINT COUVRE CARTER 2	GASKET, CRANKCASE COVER 2	JUNTA CUBRE CÁRTER 2	1
28	90105-06098-00	VIS EMBASE	SCREW, FLANGE	TORNILLO CON VALONA	2
29	99530-08016-00	DOUILLE CENTRAGE	PIN, DOWEL	CENTRADOR	2
30	S108-10904-00-00	INDICATEUR NIVEAU HUILE	OIL INDICATOR	INDICADOR NIVEL ACEITE	1
31	91317-06100-00	VIS EMBASE	SCREW, FLANGE	TORNILLO CON VALONA	1



# 10 – LANCEUR / QUICKSTART PEDAL / PEDAL DE ARRANQUE



5SG1100-2140



FIG. 10 – LANCEUR / KICKSTART PEDAL / PEDAL DE ARRANQUE

N°	REF.	FRAÇAIS	ENGLISH	ESPAÑOL	QTY
1	5NL-15601-10-00	ARBRE DÉMARREUR ASSEMBLÉ	KICK SHAFT ASSY	CONJUNTO EJE ARRANQUE	1
2	5NL-15641-10-00	PIGNON DÉMARREUR	GEAR, KICK	PIÑÓN ARRANQUE	1
3	90201-20685-00	RONDILLE	WASHER, PLATE	ARANDELA	1
4	93410-20038-00	CIRCLIP	CIRCLIP	CIRCLIP	1
5	4GY-15671-00-00	COULISSEAU DÉMARREUR	WHEEL, RATCHET	TRINQUETE ARRANQUE	1
6	90501-16016-00	RESSORT COMPRESSION	SPRING, COMPRESSION	MUELLE COMPRESIÓN	1
7	90201-167P7-00	RONDILLE	WASHER, PLATE	ARANDELA	1
8	99009-16400-00	CIRCLIP	CIRCLIP	CIRCLIP	1
9	90508-30743-00	RESSORT TORSION	SPRING, TORSION	MUELLE TORSIÓN	1
10	5NL-15664-00-00	GUIDE, RESSORT	GUIDE, SPRING	CASQUILLO CENTRADOR MUELLE	1
11	90201-162H4-00	RONDILLE	WASHER, PLATE	ARANDELA	1
12	5SG-15668-00-00	PION D'ARRÊT	STOPPER	TOPE TRINQUETE	1
13	214-15686-00-00	BUTÉE	WASHER, LOCK	PLATINA TRINQUETE	1
14	90101-06001-00	VIS	SCREW	TORNILLO	2
15	93102-18278-00	JOINT D'ÉTANCHÉITÉ	OIL SEAL	JUNTA ESTANQUEIDAD	1
16	5NL-15651-00-00	PIGNON INTERMÉDIAIRE	GEAR, KICK IDLE	PIÑÓN INTERMEDIO	1
17	90201-177G4-00	RONDILLE	WASHER, PLATE	ARANDELA	1
18	99009-17400-00	CIRCLIP	CIRCLIP	CIRCLIP	1
19	S10B-11402-00-00	KICK	KICK	PEDAL ARRANQUE	1
20	5NX-15621-01-00	NOIX KICK	BOSS, KICK CRANK	MANIVELA PEDAL ARRANQUE	1
21	90501-147A5-00	RESSORT MANIVELLE	SPRING, COMPRESSION	MUELLE MANIVELA	1
22	93507-32031-00	BILLE	BALL	BOLA	1
23	90152-06010-00	VIS NOYÉE	SCREW, COUNTERSINK	TORNILLO AHOGADO	1
24	93210-17570-00	JOINT TORIQUE	O-RING	TÓRICA	1
25	90201-08326-00	RONDILLE	WASHER, PLATE	ARANDELA	1
26	90109-085E2-00	VIS	SCREW	TORNILLO	1



# 11 – EMBRAYAGE / CLUTCH / EMBRAGUE

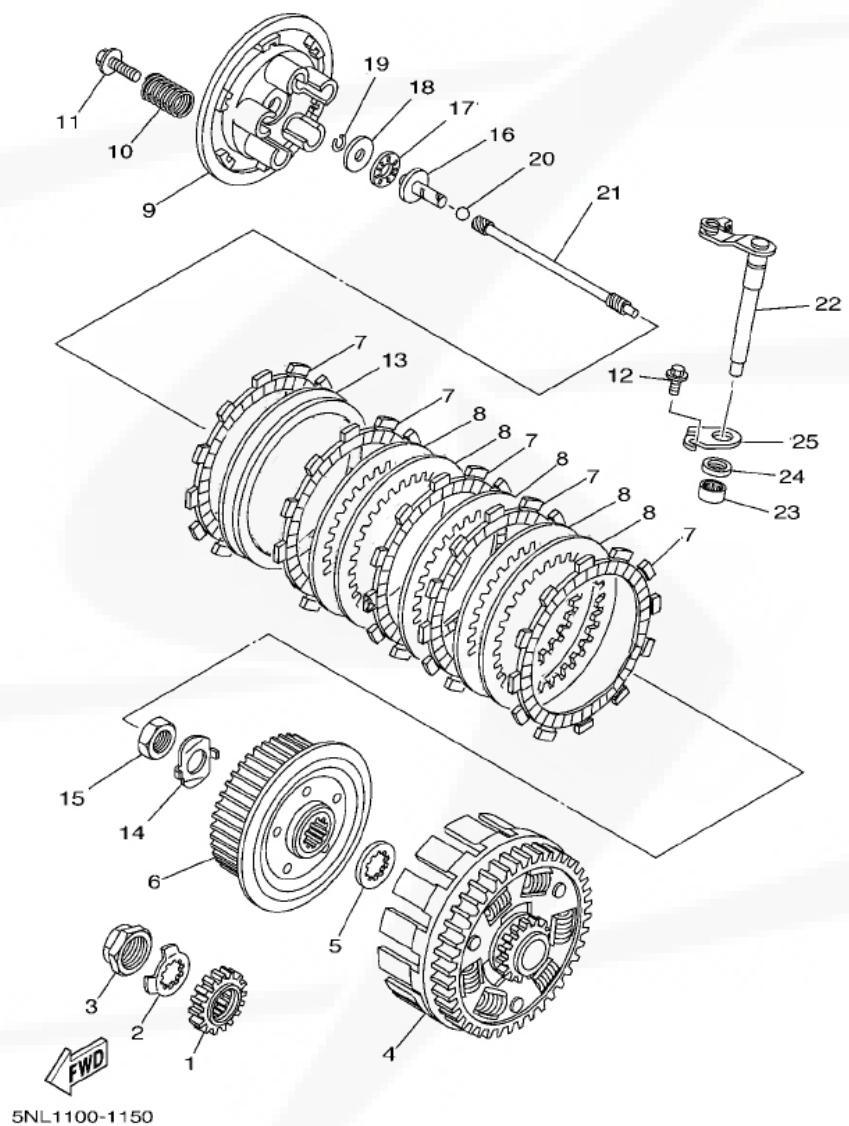



FIG. 11 - EMBRAYAGE / CLUTCH / EMBRAGUE

N°	REF.	FRANÇAIS	ENGLISH	ESPAÑOL	QTY
1	5NL-16111-00-00	PIGNON PRIMAIRE VILEBREQUIN	GEAR, PRIMARY DRIVE	PIÑÓN CIGÜEÑAL TRANS. PRIMARIA	1
2	90215-20003-00	RONDELLE ARRÊT	WASHER, LOCK	ARANDELA	1
3	90179-18001-0	ECROU	NUT	TUERCA	1
4	5NL-16150-10-00	CLOCHE EMBRAYAGE	PRIMARY DRIVEN GEAR COMP.	CAMPANA EMBRAGUE	1
5	5NL-16154-00-00	RONDELLE CRÉNELÉE	PLATE, THRUST	ARANDELA	1
6	5NL-16371-00-00	NOYAU EMBRAYAGE	BOSS, CLUTCH	CUBO EMBRAGUE	1
7	5DH-16321-00-00	DISQUE GARNI	PLATE, FRICTION	DISCO FORRADO	5
8	5NL-16325-00-00	DISQUE LISSE	PLATE, CLUTCH	DISCO METÁLICO	5
9	5HD-16351-00-00	PLATEAU	PLATE, PRESSURE	Prensa EMBRAGUE	1
10	90501-224J9-00	RESSORT COMPRESSION	SPRING, COMPRESSION	MUELLE COMPRESIÓN	5
11	90159-06092-00	VIS	SCREW WITH WASHER	TORNILLO	5
12	95027-06010-00	VIS EMBASE	SCREW, FLANGE	TORNILLO CON VALONA	1
13	S108-11000-00-00	CALE EMBRAYAGE	CLUTCH FIX	CUÑA EMBRAGUE	1
14	90215-16289-00	RONDELLE ARRÊT	WASHER, LOCK	ARANDELA	1
15	90170-16326-00	ECROU	NUT	TUERCA	1
16	5NL-16356-00-00	POUSSOIR DE PLATEAU	ROD, PUSH 1	EMPUJADOR EMBRAGUE	1
17	93340-21008-00	ROULEMENT	BEARING	COJINETE	1
18	90201-080H1-00	RONDELLE	WASHER, PLATE	ARANDELA	1
19	93440-07182-00	CIRCLIP	CIRCLIP	CIRCLIP	1
20	93511-32027-00	BILLE	BALL	BOLA	1
21	5NL-16357-10-00	TIGE DE POUSSÉE	ROD, PUSH 2	VARILLA EMBRAGUE	1
22	S108-11001-00-00	LEVIER DÉBRAYAGE	PUSH LEVER COMP.	PALANCA DESEMBRAGUE	1
23	93317-11287-00	ROULEMENT	BEARING	COJINETE	1
24	93102-12224-00	JOINT D'ÉTANCHÉITÉ	OIL SEAL	JUNTA ESTANQUEIDAD	1
25	4JT-16384-00-00	SUPPORT LEVIER	PLATE, SEAT	SOPORTE PALANCA	1



## 12 – BOITE A VITESSES / GEAR SET / CAMBIO

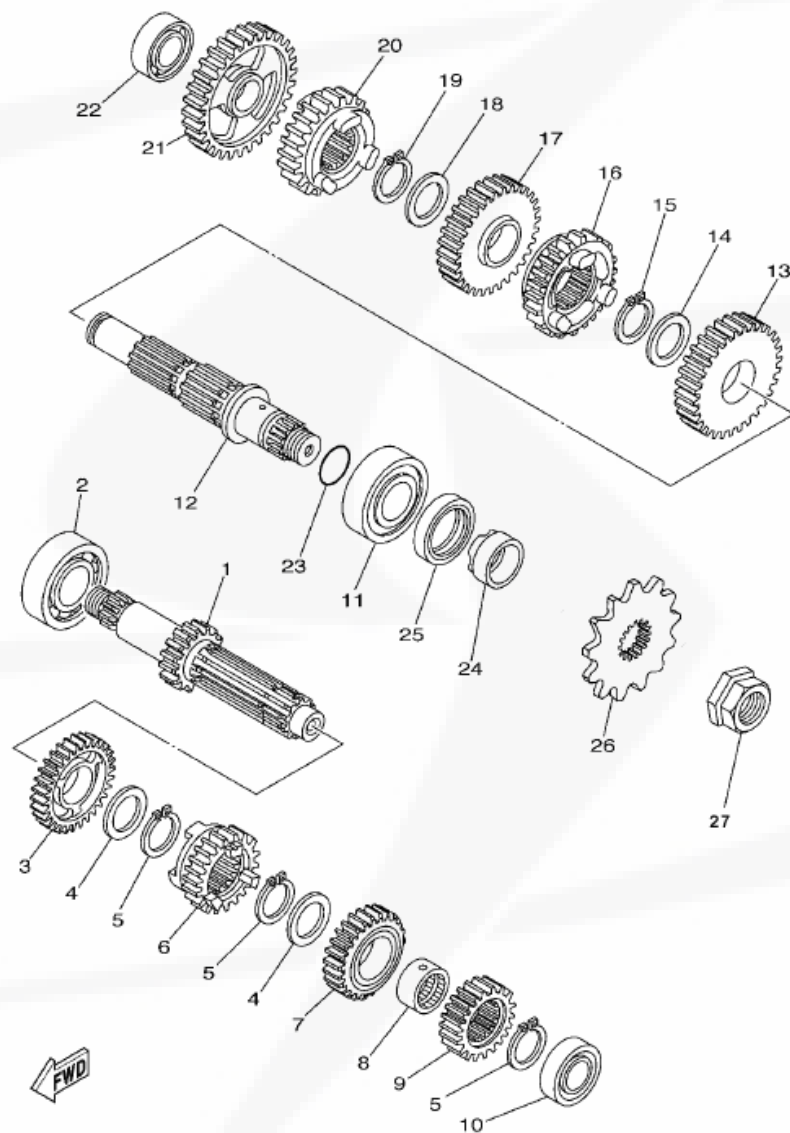



FIG. 12 - BOÎTE À VITESSES / GEAR SET / CAMBIO

N°	REF.	FRANÇAIS	ENGLISH	ESPAÑOL	QTY
1	5PH-17411-10-00	AXE PRIMAIRE (13D)	AXLE, MAIN (13T)	EJE PRIMARIO (13D)	1
2	93306-20447-00	ROULEMENT	BEARING	COJINETE	1
3	OWL3-17151-00	PIGNON PRIMAIRE 5ÈME (29D)	GEAR, 5TH PINION (29T)	PIÑÓN PRIMARIO 5A (29D)	1
4	90209-20008-00	RONDILLE	WASHER	ARANDELA	2
5	93410-22039-00	CIRCLIP	CIRCLIP	CIRCLIP	3
6	OWL3-17131-00	PIGNON PRIMAIRE 3ÈME (15D)	GEAR, 3RD PINION (15T)	PIÑÓN PRIMARIO 3A (15D)	1
7	5PH-17141-10-00	PIGNON PRIMAIRE 4ÈME (24D)	GEAR, 4TH PINION (24T)	PIÑÓN PRIMARIO 4A (24D)	1
8	90387-20006-00	ROULEMENT	BEARING	COJINETE	1
9	OWL3-17121-00	PIGNON PRIMAIRE 2NDE (13D)	GEAR, 2ND PINION (13T)	PIÑÓN PRIMARIO 2A (13D)	1
10	93306-00320-00	ROULEMENT	BEARING	COJINETE	1
11	93306-27208-00	ROULEMENT	BEARING	COJINETE	1
12	5NL-17402-00-00	AXE SECONDAIRE	DRIVE AXLE ASSY	EJE SECUNDARIO	1
13	OWL3-17231-00	PIGNON SECONDAIRE 2NDE (26D)	GEAR, 2ND WHEEL (26T)	PIÑÓN SECUNDARIO 2A (26D)	1
14	90209-23012-00	RONDILLE	WASHER	ARANDELA	1
15	93410-26067-00	CIRCLIP	CIRCLIP	CIRCLIP	1
16	5PH-17241-10-00	PIGNON SECONDAIRE 4ÈME (25D)	GEAR, 4TH WHEEL (25T)	PIÑÓN SECUNDARIO 4A (25D)	1
17	OWL3-17231-00	PIGNON SECONDAIRE 3ÈME (25D)	GEAR, 3RD WHEEL (25T)	PIÑÓN SECUNDARIO 3A (25D)	1
18	90209-20008-00	RONDILLE	WASHER	ARANDELA	1
19	93410-22039-00	CIRCLIP	CIRCLIP	CIRCLIP	1
20	OWL3-17251-00	PIGNON SECONDAIRE 5ÈME (20D)	GEAR, 5TH WHEEL (20T)	PIÑÓN SECUNDARIO 5A (20D)	1
21	5PH-17211-00-00	PIGNON SECONDAIRE 1ÈRE (31D)	GEAR, 1ST WHEEL (31T)	PIÑÓN SECUNDARIO 1A (31D)	1
22	93306-00317-00	ROULEMENT	BEARING	COJINETE	1
23	93210-196A4-00	JOINT TORIQUE	O-RING	TÓRICA	1
24	90387-22001-00	BAGUE	COLLAR	COLLAR	1
25	93102-28010-00	JOINT D'ÉTANCHÉITÉ	OIL SEAL	JUNTA ESTANQUEIDAD	1
26	9P000-00520-09	PIGNON DE SORTIE 9D	SPROCKET, DRIVE 9T	PIÑÓN DE SALIDA 9D	1
27	90179-18001-00	ECROU	NUT	TUERCA	1

LONG-RIDE

N°	REF.	FRANÇAIS	ENGLISH	ESPAÑOL	QTY
26	9P000-00520-10	PIGNON DE SORTIE 10D	SPROCKET, DRIVE 10T	PIÑÓN DE SALIDA 10D	1



### 13 – BARILLET FOURCHETTE / SHIFT CAM. FORK / HORQUILLAS DE CAMBIO

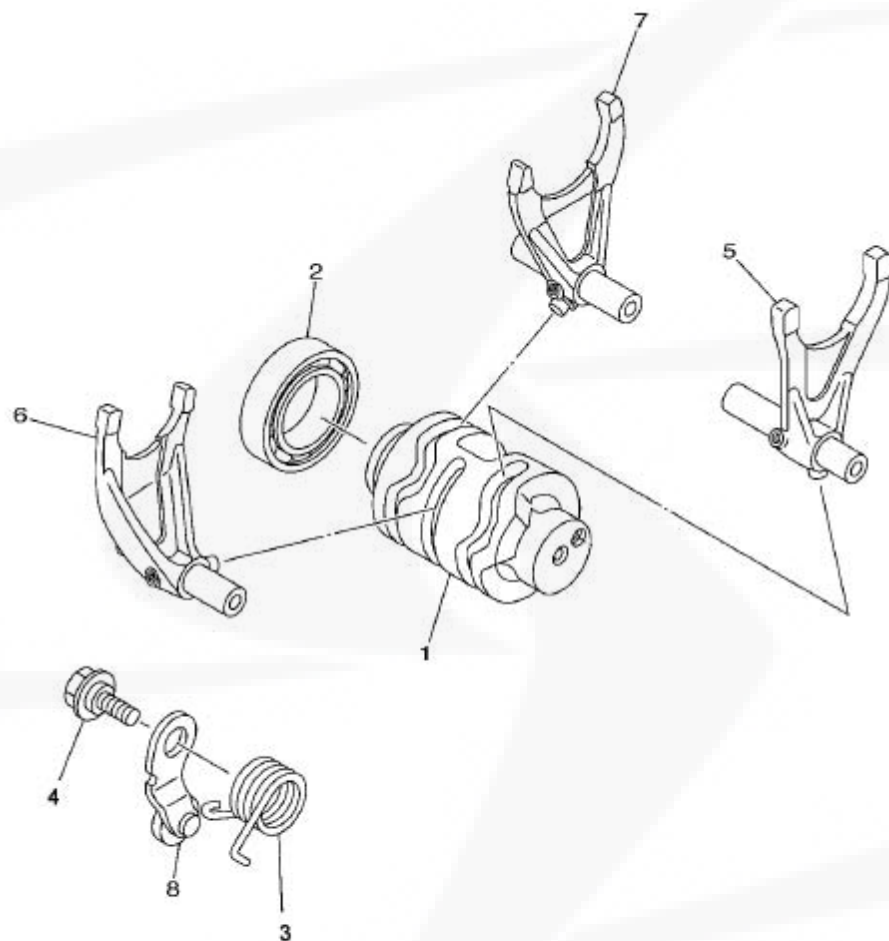

5NL1100-1170





FIG. 13 - BARILLET FOURCHETTE / SHIFT CAM. FORK / HORQUILLAS DE CAMBIO

N°	REF.	FRANÇAIS	ENGLISH	ESPAÑOL	QTY
1	5NL-18541-00-00	TAMBOUR SÉLECTION	CAM, SHIFT	DESMO SELECTOR	1
2	93306-90501-00	ROULEMENT	BEARING	COJINETE	1
3	90508-26561-00	RESSORT VERROUILLAGE	SPRING, TORSION	MUELLE FIJADOR MARCHAS	1
4	90109-063F8-00	Vis	SCREW	TORNILLO	1
5	5NL-18501-000-00	FOURCHETTE 1	FORK, SHIFT 1	HORQUILLA 1	1
6	S10B-11121-00-00	FOURCHETTE 2	FORK, SHIFT 2	HORQUILLA 2	1
7	S10B-11131-00-00	FOURCHETTE 3	FORK, SHIFT 3	HORQUILLA 3	1
8	3XK-18140-00-00	LEVIER DE VERROUILLAGE	STOPPER LEVER ASSY	FIJADOR MARCHAS	1





FIG. 14 - SÉLECTEUR / SHIFT SHAFT / SÉLECTEUR

N°	REF.	FRANÇAIS	ENGLISH	ESPAÑOL	QTY
1	4EW-18185-00-00	ETOILE DE SÉLECTION	SEGMENT	ESTRELLA SELECTOR	1
2	3XJ-18173-00-00	VIS CENTRAGE	PIN, SHIFT	TORNILLO CENTRADOR	1
3	5BE-18172-00-00	SCORPION	GUIDE, SHIFT	ESCORPIÓN	1
4	90101-06041-00	VIS	SCREW	TORNILLO	2
5	5LP-18122-01-00	LEVIER SÉLECTION	LEVER, SHIFT	SELECTOR	1
6	90501-05265-00	RESSORT COMPRESSION	SPRING, COMPRESSION	MUELLE COMPRESIÓN	2
7	3XJ-18184-00-00	GOUPILLE CLIQUET	PIN, PAWL	PASADOR TRINQUETE	2
8	3XJ-18182-00-00	CLIQUET	PAWL, SHIFTER	TRINQUETE	2
9	3XJ-18178-00-00	ENTRETOISE LEVIER	ROLLER, SHIFT LEVER	CASQUILLO SELECTOR	1
10	5UL-18101-00-00	ARBRE SÉLECTEUR	SHIFT SHAFT ASSY	EJE SELECTOR	1
11	90387-124F4-00	ENTRETOISE	COLLAR	CASQUILLO	1
12	90508-291A8-00	RESSORT TORSION	SPRING, TORSION	MUELLE TORSIÓN	1
13	93608-33002-00	DOUILLE CENTRAGE	PIN, DOWEL	CENTRADOR	1
14	93102-12224-00	JOINT D'ÉTANCHÉITÉ	OIL SEAL	JUNTA ESTANQUEIDAD	1
15	5UL-18110-00-00	SÉLECTEUR	SHIFT PEDAL ASSY	PALANCA	1
16	95027-06020-00	VIS SERRAGE SÉLECTEUR	SCREW, FLANGE	TORNILLO SUJECIÓN PALANCA	1



15 – ALLUMAGE / IGNITION / ENCENDIDO

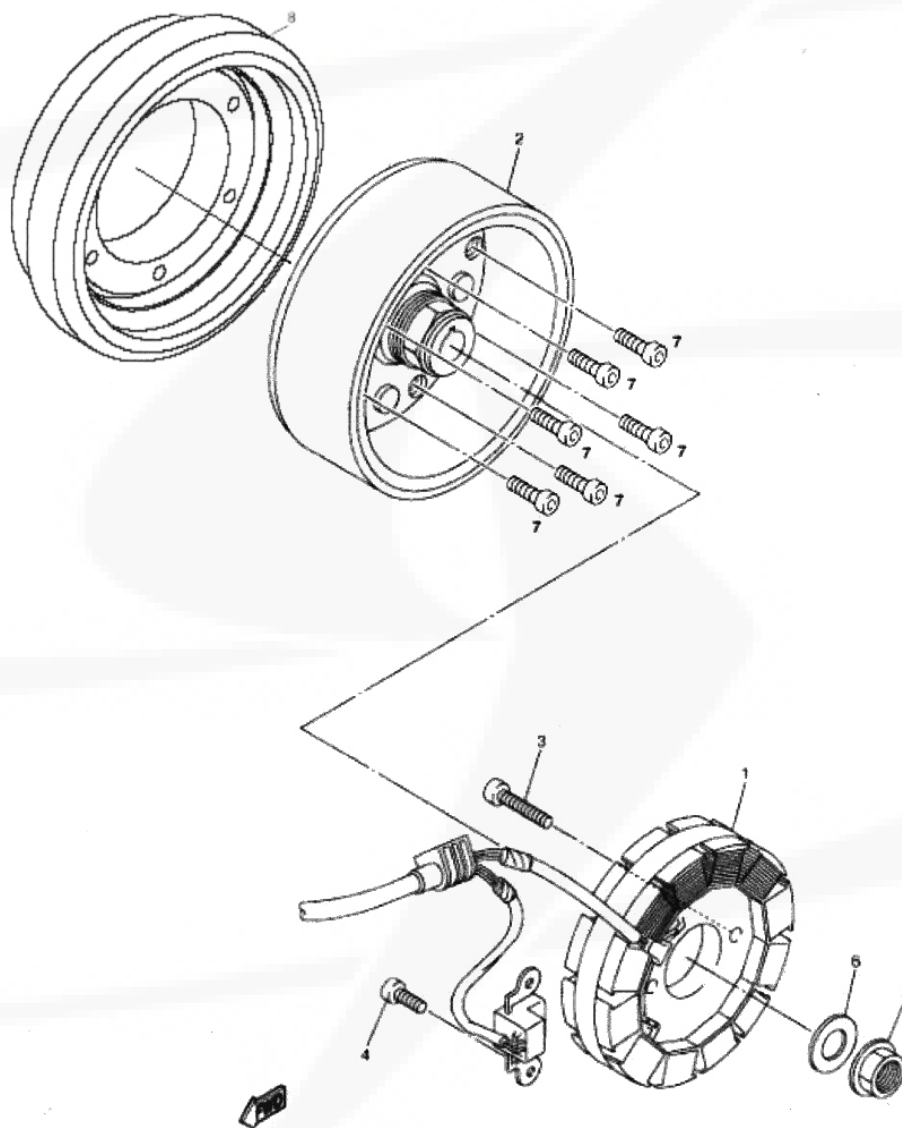



FIG. 15 - ALLUMAGE / IGNITION / ENCENDIDO

N°	REF.	FRANÇAIS	ENGLISH	ESPAÑOL	QTY
1	5UM-81410-20-00	STATOR	STATOR ASSY	ESTATOR	1
2	5UM-81450-00-00	ROTOR	ROTOR ASSY	ROTOR	1
3	91317-05020-00	VIS STATOR	SCREW, STATOR	TORNILLO ESTATOR	2
4	91317-06014-00	VIS	SCREW, ROTOR	TORNILLO	2
5	90179-12657-00	ECROU SERRAGE	NUT	TUERCA SUJECIÓN	1
6	90201-12020-00	RONDILLE SERRAGE	WASHER, PLATE	ARANDELA SUJECIÓN	1
7	9CH00-06020-00	VIS MASSE	SCREW, MASS	TORNILLO MASA	6
8	S10B-10206-00-00	MASSE ADDITIONNELLE ROTOR	ROTOR ADDITIONAL MASS	MASA ADICIONAL ROTOR	1



# 16 – CARBURATEUR / CARBURETTOR / CARBURADOR

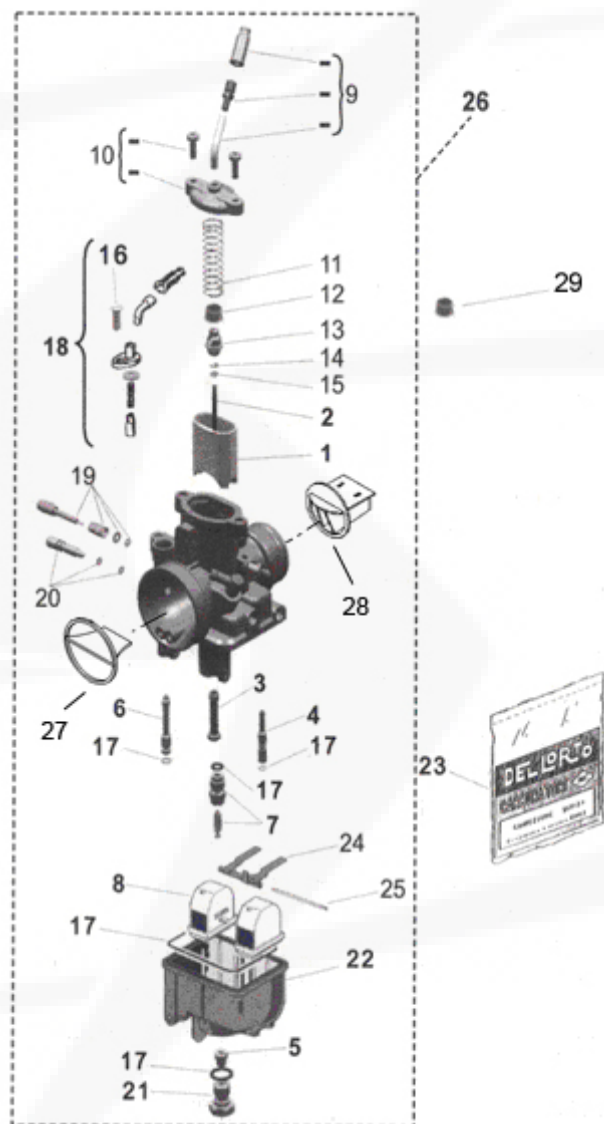



FIG. 16 – CARBURATEUR / CARBURETTOR / CARBURADOR

N°	REF.	FRANÇAIS	ENGLISH	ESPAÑOL	QTY
1*	S10B-10713-45-00	BOISSEAU	VALVE	COMPUERTA	1
2*	S10B-10714-D4-90	AIGUILLE	NEEDLE	AGUJA	1
3*	S10B-10717-26-8K	PUITS D'AIGUILLE	NOZZLE, MAIN	EMULSOR	1
4*	S10B-10719-35-00	GICLEUR RALENTI	JET, PILOT	CHICLE RALENTI	1
5*	S10B-10725-10-40	GICLEUR PRINCIPAL	JET, MAIN	CHICLE PRINCIPAL	1
6*	S10B-10718-40-00	GICLEUR STARTER	JET, STARTER	CHICLE STARTER	1
7*	S10B-10720-20-00	POINTEAU	NEEDLE VALVE SET	VÁLVULA FLOTADOR	1
8*	S10B-10723-00-00	FLOTTEURS	FLOAT	FLOTADOR	2
9*	S10B-10708-00-00	VIS TENSION CÂBLE	CABLE ADJUST SCREW SET	CONJUNTO TENSOR CABLE	1
10*	S10B-10709-00-00	COUVERCLE ET VIS	COVER AND SCREW	TAPA Y TORNILLO	1
11*	S10B-10710-00-00	RESSORT	SPRING	MUELLE	1
12*	9E004-09011-10	SIÈGE RESSORT	SPRING END	ARANDELA MUELLE	1
13*	S10B-10712-00-00	SUPPORT AIGUILLE	NEEDLE END	SOPORTE AGUJERA	1
14*	9ROPL-03005-00	RONDELLE	WASHER	ARANDELA	1
15*	9CIRC-02006-00	CIRCLIP	CIRCLIP	CIRCLIP	1
16*	9OTFO-05014-00	VIS	SCREW	TORNILLO	1
17*	S10B-10707-00-00	KIT JOINT	GASKET KIT	KIT JUNTAS	1
18*	S10B-10711-00-00	STARTER	STARTER KIT	MANDO STARTER	1
19*	S10B-10716-00-00	VIS DE RICHESSE	MIX SCREW SET	TORNILLO REGULACIÓN ENTRADA AIRE	1
20*	S10B-10715-00-00	VIS DE RALENTI	THROTTLE SCREW SET	TORNILLO REGULACIÓN COMPUERTA	1
21*	S10B-10726-00-00	SUPPORT GICLEUR PRINCIPAL	PLUG, MAIN JET	SOPORTE CHICLE PRINCIPAL	1
22*	S10B-10727-00-00	CUVE	TANK	CUBETA GASOLINA	1
23*	S10B-10731-00-00	KIT PIÈCES	PARTS KIT	KIT PIEZAS	1
24*	S10B-10721-00-00	BALANCIER FLOTTEURS	FLOAT BEAM	BALANCÍN FLOTADOR	1
25*	S10B-10722-00-00	AXE BALANCIER FLOTTEUR	AXLE, FLOAT BEAM	EJE FLOTADOR	1
26	S10B-10700-00-00	CARBURATEUR COMPLET VHST 26	CARBURETTOR ASSY VHST 26	CARBURADOR COMPLETO VHST 26	1
27	S10C-10728-00-00	DIFFUSEUR FILTRE À AIR	AIR FILTER DIFFUSER	DIFUSOR FILTRO DE AIRE	1
28	S10C-10610-00-00	DIFFUSEUR CULASSE	HEAD CYLINDER DIFFUSER	DIFUSOR CULATA	1
29	S10B-10703-00-00	BRIDE CARBURATEUR	BRIDE, CARBURETTOR	BRIDA CARBURADOR	1

\* INCLUS DANS CARBURATEUR COMPLET / INCLUDED IN CARBURETTOR ASSY / INCLUIDO EN CARBURADOR COMPLETO

LONG-RIDE

N°	REF.	FRANÇAIS	ENGLISH	ESPAÑOL	QTY
5*	S10B-10725-11-20	GICLEUR PRINCIPAL 112	JET, MAIN 112	CHICLE PRINCIPAL 112	1
7*	S10B-10720-35-00	POINTEAU 350	NEEDLE VALVE SET 350	VÁLVULA FLOTADOR 350	1



CHÂSSIS / FRAME / CHASIS  
PARTLIST





# 17 – CADRE / FRAME / BASTIDOR

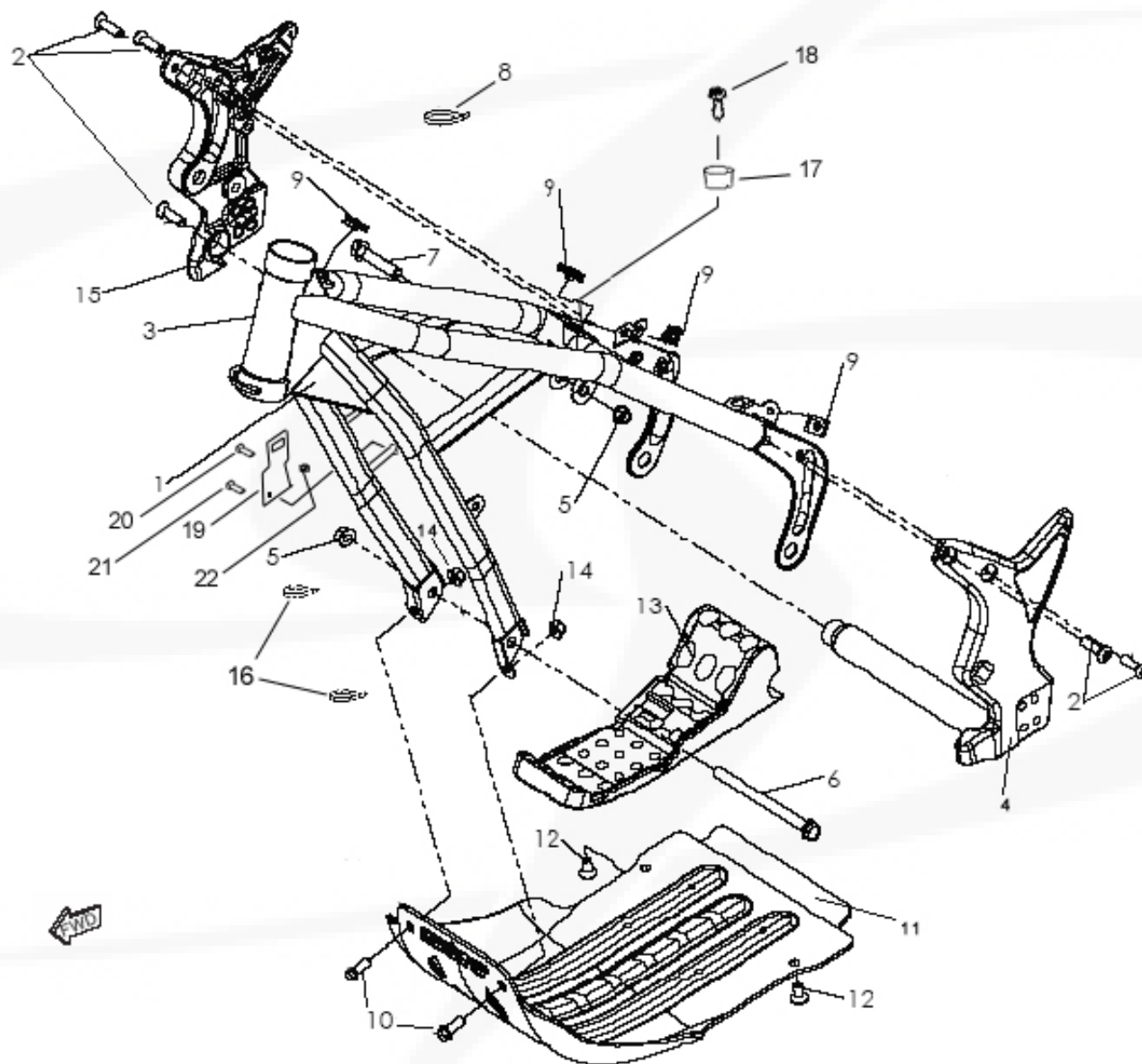



FIG. 17 – CADRE / FRAME / BASTIDOR

N°	REF.	FRANÇAIS	ENGLISH	ESPAÑOL	QTY
1	S10B-20101-00-07	CADRE	FRAME	BASTIDOR	1
2	90109-08161-00	VIS PLATINE	SCREW LOWER FRAME	TORNILLO PLETINA	5
3	S10B-90602-00-00	ADHÉSIF NUMÉRO CHÂSSIS	FRAME NUMBER STICKER	ADHESIVO NUMERO BASTIDOR	1
4	S10B-20105-00-10	PLATINE GAUCHE	LEFT LOWER FRAME	PLETINA ALUMINIO IZQUIERDA	1
5	90185-10002-00	ECROU FIXATION MOTEUR	NUT, ENGINE FIX	TUERCA FIJACIÓN MOTOR	2
6	95817-10130-00	VIS FIXATION MOTEUR AVANT	SCREW, FRONT ENGINE FIX	TORNILLO FIJACIÓN MOTOR DELANTERA	1
7	95817-10050-00	VIS FIXATION MOTEUR SUPÉRIEURE	SCREW, UPPER ENGINE FIX	TORNILLO FIJACIÓN MOTOR SUPERIOR	1
8	9CORY-48280-NO	COLLIER RISLAN 4.8*280	LOCKING COLLAR 4.8*280	ABRAZADERA 4.8*280	1
9	9CE06-15822-00	CLIP ÉCROU	NUT CLIP	GRAPA TUERCA	4
10	90109-085E2-00	VIS FIXATION SABOT AVANT	SCREW, FRONT GUARD FIX	TORNILLO FIJACIÓN PROTECCIÓN MOTOR DELANTERA	2
11	S10B-20102-00-00	SABOT	GUARD, ENGINE	PLACA PROTECCIÓN MOTOR	1
12	9FHCO-08020-00	VIS FIXATION SABOT ARRIÈRE	SCREW, REAR GUARD FIX	TORNILLO FIJACIÓN PROTECCIÓN MOTOR TRASERA	2
13	S10B-20103-00-00	TAMPON SABOT	PAD, ENGINE GUARD	GOMA PROTECTOR MOTOR	1
14	90185-08169-00	ECROU FIXATION SABOT	NUT, GUARD FIX	TUERCA FIJACIÓN PROTECCIÓN MOTOR	2
15	S10B-20106-00-10	PLATINE DROITE	RIGHT LOWER FRAME	PLETINA ALUMINIO DERECHA	1
16	9CORY-36140-NO	COLLIER RISLAN 3.6*140	LOCKING COLLAR 3.6*140	ABRAZADERA 3.6*140	2

LONG-RIDE

N°	REF.	FRANÇAIS	ENGLISH	ESPAÑOL	QTY
17	S1A-80206-00-00	TAMPON	PAD	TAPÓN	1
18	9CHCO-06025-00	VIS FIXATION TAMPON	SCREW, PAD	TORNILLO FIJACIÓN TAPÓN	1
19	S10D-20108-00-00	PLAQUE NUMÉRO PILOTE	PLATE, RIDER NUMBER	PLACA NUMERO PILOTO	1
20	9BHCE-05016-NO	VIS PLAQUE NUMÉRO SUPÉRIEURE	SCREW, RIDER NUMBER PLATE UPPER	TORNILLO PLACA NUMERO SUPERIOR	1
21	9BHCE-05012-NO	VIS PLAQUE NUMÉRO INFÉRIEURE	SCREW, RIDER NUMBER PLATE LOWER	TORNILLO PLACA NUMERO INFERIOR	1
22	9EC08-05000-00	ECROU PLAQUE NUMÉRO	NUT, RIDER NUMBER PLATE	TUERCA PLACA NUMERO	1



# 18 – FOURCHE / FRONT FORK / HORQUILLA

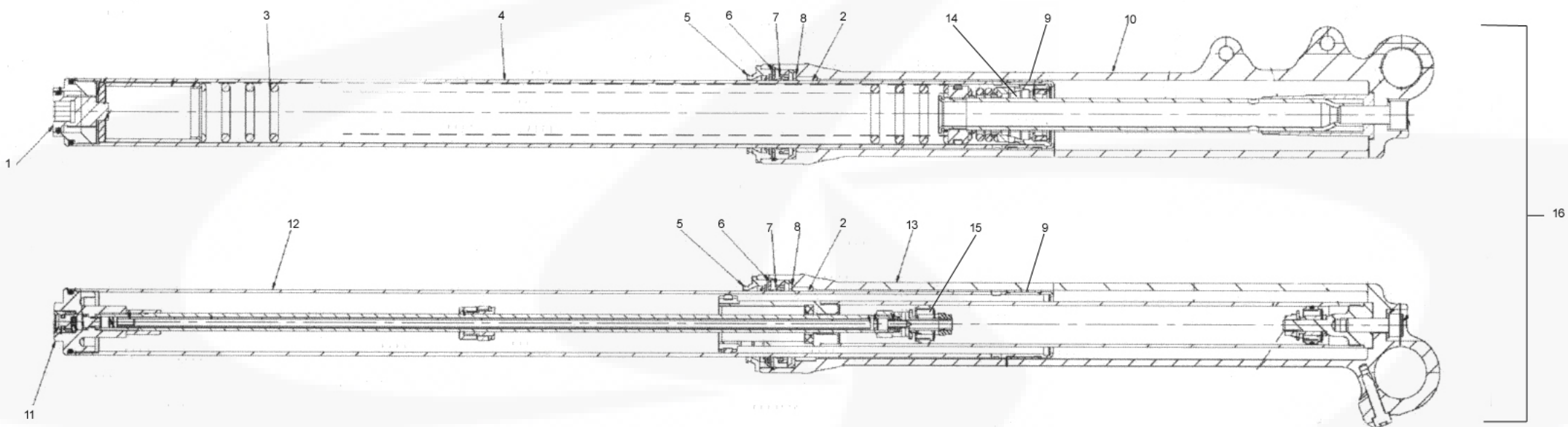



FIG. 18 - FOURCHE / FRONT FORK / HORQUILLA

N°	REF.	FRANÇAIS	ENGLISH	ESPAÑOL	QTY
1	S108-70102-00-00	BOUCHON TUBE GAUCHE	CAP, LEFT INNER TUBE	TAPÓN TUBO HORQUILLA IZQUIERDO	1
2	8151	BAGUE DE GUIDAGE SUPÉRIEURE	METAL, SLIDE UPPER	GUÍA SUPERIOR	1
3	S108-70110-00-00	RESSORT JAMBE GAUCHE	SPRING, LEFT FORK LEG	MUELLE BARRA IZQUIERDA	1
4	S108-70101-00-00	TUBE FOURCHE GAUCHE	INNER TUBE, LEFT FORK LEG	TUBO	1
5	S1A-70108-00-00	CACHE POUSSIÈRE	DUST SEAL	GUARDAPOLVO	2
6	S1A-70109-00-00	JONC MAINTIEN JOINT SPI	SNAP RING	CIRCLIP	2
7	S1A-70111-00-00	JOINT SPI	OIL SEAL	RETÉN	2
8	S108-70113-00-00	RONDELLE	WASHER, OIL SEAL	ARANDELA	2
9	8071	BAGUE DE GUIDAGE INFÉRIEURE	METAL, SLIDE LOWER	GUÍA INFERIOR	2
10	S108-70301-00-00	FOURREAU FOURCHE GAUCHE	OUTER TUBE, LEFT FORK LEG	BOTELLA HORQUILLA IZQUIERDA	1
11	S108-70202-00-00	BOUCHON TUBE DROIT	CAP, RIGHT INNER TUBE	TAPÓN TUBO DERECHO	1
12	S108-70201-00-00	TUBE FOURCHE DROIT	INNER TUBE, RIGHT FORK LEG	TUBO HORQUILLA DERECHO	1
13	S108-70401-00-00	FOURREAU FOURCHE DROIT	OUTER TUBE, RIGHT FORK LEG	BOTELLA HORQUILLA DERECHA	1
14	0000-00000-00-00	CARTOUCHE COMPRESSION	CARTRIDGE, COMPRESSION	PISTÓN COMPRESIÓN	1
15	0000-00000-00-00	CARTOUCHE DÉTENTE	CARTRIDGE, EXTENSION	PISTÓN EXTENSIÓN	1
16	S108-70300-00-00	FOURCHE COMPLÈTE	FRONT FORK ASSY	HORQUILLA COMPLETA	1



19 – DIRECTION / STEERING / DIRECCIÓN

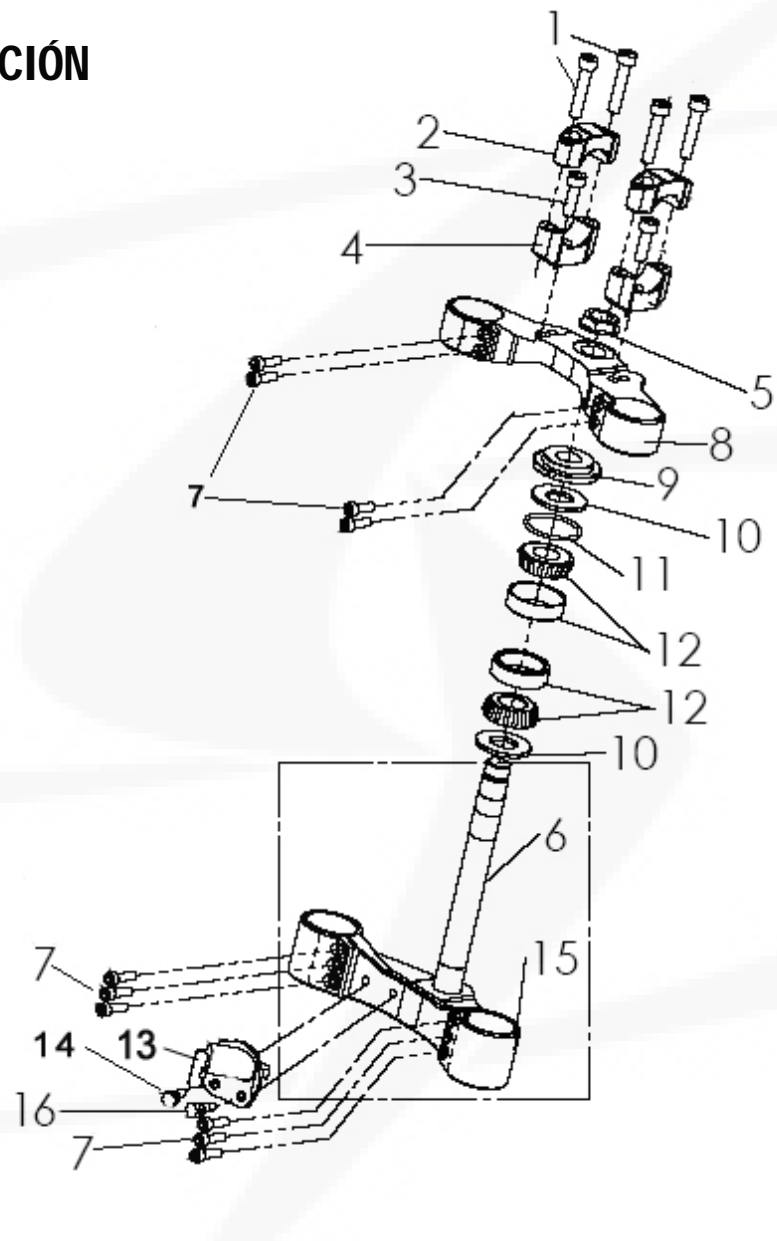



FIG. 19 – DIRECTION / STEERING / DIRECCIÓN

N°	REF.	FRANÇAIS	ENGLISH	ESPAÑOL	QTY
1	91317-08035-00	VIS PONTET SUPÉRIEUR	SCREW, HOLDER HANDLE UPPER	TORNILLO BRIDA MANILLAR SUPERIOR	4
2	S10B-70603-00-00	PONTET SUPÉRIEUR	HOLDER HANDLE UPPER	BRIDA MANILLAR SUPERIOR	2
3	91317-08025-00	VIS PONTET INFÉRIEUR	SCREW, HOLDER HANDLE LOWER	TORNILLO BRIDA MANILLAR INFERIOR	2
4	S10B-70602-00-00	PONTET INFÉRIEUR	HOLDER HANDLE LOWER	BRIDA MANILLAR INFERIOR	2
5	S2A-70604-00-00	ECROU PIVOT DIRECTION	NUT, STEERING SHAFT	TUERCA DIRECCIÓN	1
6	S10B-70505-00-00	PIVOT DIRECTION	STEERING AXLE	EJE DIRECCIÓN	1
7	91317-06020-00	VIS SERRAGE TÉ	SCREW, CLAMP TIGHTENING	TORNILLO SUJECIÓN PLATINA	10
8	S10B-70601-00-00	TÉ DE FOURCHE SUPÉRIEUR	TRIPLE CLAMP, UPPER	PLATINA SUPERIOR	1
9	S1A-70503-00-00	ECROU SERRAGE	NUT, TIGHTENING	TUERCA SUJECIÓN	1
10	S1A-70504-00-00	RONDELLE ALU	WASHER	ARANDELA ALUMINIO	2
11	9JTT0-02538-00	JOINT TORIQUE	O RING	TÓRICA	1
12	S10B-70502-00-00	ROULEMENT DIRECTION	BEARING, STEERING	COJINETE DIRECCIÓN	2
13	S10B-60606-00-00	BLOCAGE DIRECTION	STEERING LOCK	BLOQUEO DE DIRECCIÓN	1
14	9VSAC-06024-00	VIS BLOCAGE DIRECTION	SCREW, STEERING LOCK	TORNILLO BLOQUEO DE DIRECCIÓN	1
15	S10B-70501-00-00	TÉ DE FOURCHE INFÉRIEUR	TRIPLE CLAMP, LOWER	PLATINA INFERIOR	1
16	9BHCO-06016-00	VIS BLOCAGE DIRECTION	SCREW, STEERING LOCK	TORNILLO BLOQUEO DE DIRECCIÓN	1



20 – AMORTISSEUR / REAR SHOCK / AMORTIGUADOR

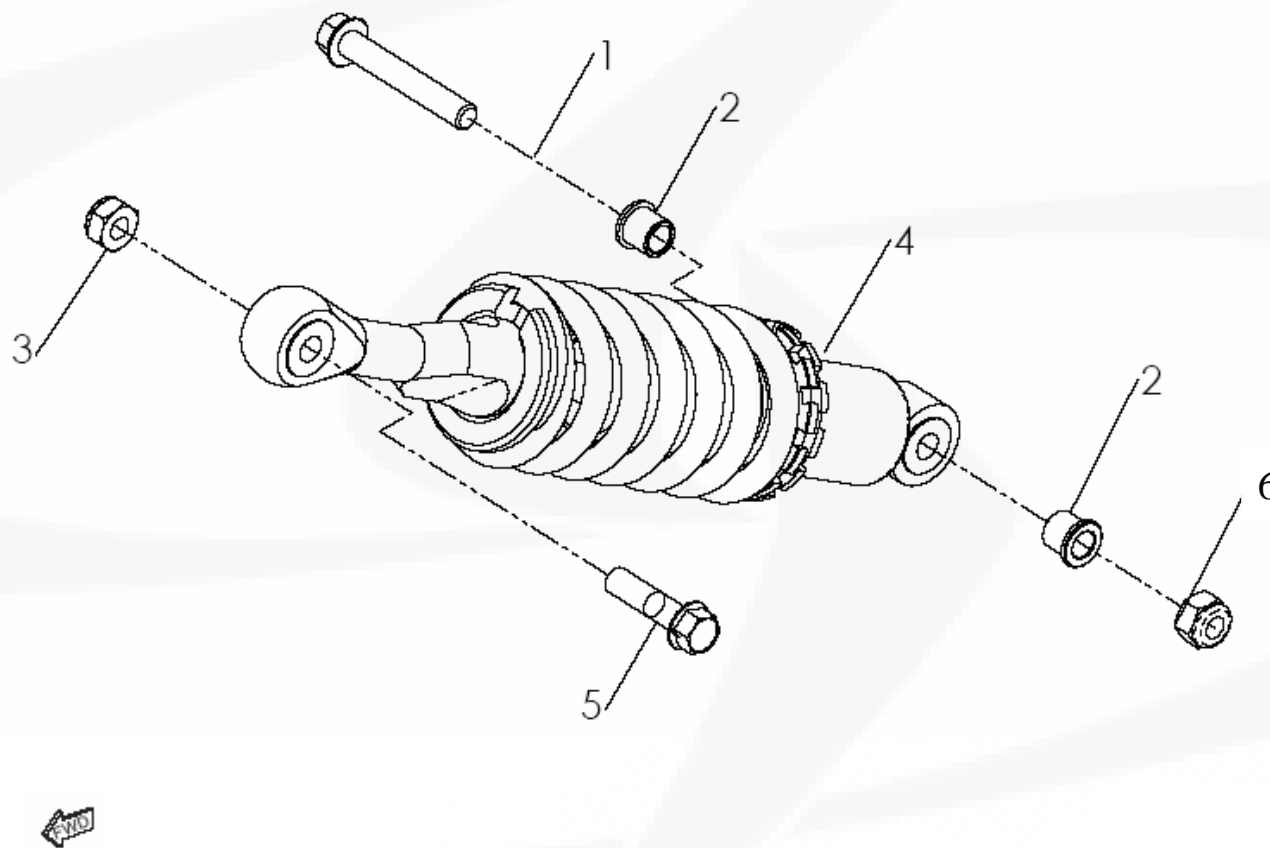



FIG. 20 – AMORTISSEUR / REAR SHOCK / AMORTIGUADOR

N°	REF.	FRANÇAIS	ENGLISH	ESPAÑOL	QTY
1	9CH00-10065-00	AXE INFÉRIEUR AMORTISSEUR	AXLE, REAR SHOCK LOWER	EJE INFERIOR AMORTIGUADOR	1
2	9E014-10018-14	ENTRETOISE AXE INFÉRIEUR AMORTISSEUR	SPACER, REAR SHOCK AXLE LOWER	CASQUILLO EJE INFERIOR AMORTIGUADOR	2
3	90185-10002-00	ECROU AXE SUPÉRIEUR AMORTISSEUR	NUT, REAR SHOCK AXLE UPPER	TUERCA EJE SUPERIOR AMORTIGUADOR	1
4	S108-20501-00-00	AMORTISSEUR ARRIÈRE	REAR SHOCK	AMORTIGUADOR	1
5	95027-10040-00	AXE SUPÉRIEUR AMORTISSEUR	AXLE, REAR SHOCK UPPER	EJE SUPERIOR AMORTIGUADOR	1
6	5186	ECROU AXE INFÉRIEUR AMORTISSEUR	NUT, REAR SHOCK AXLE LOWER	TUERCA EJE INFERIOR AMORTIGUADOR	1





21 – BRAS OSCILLANT / SWINGARM / BASCULANTE

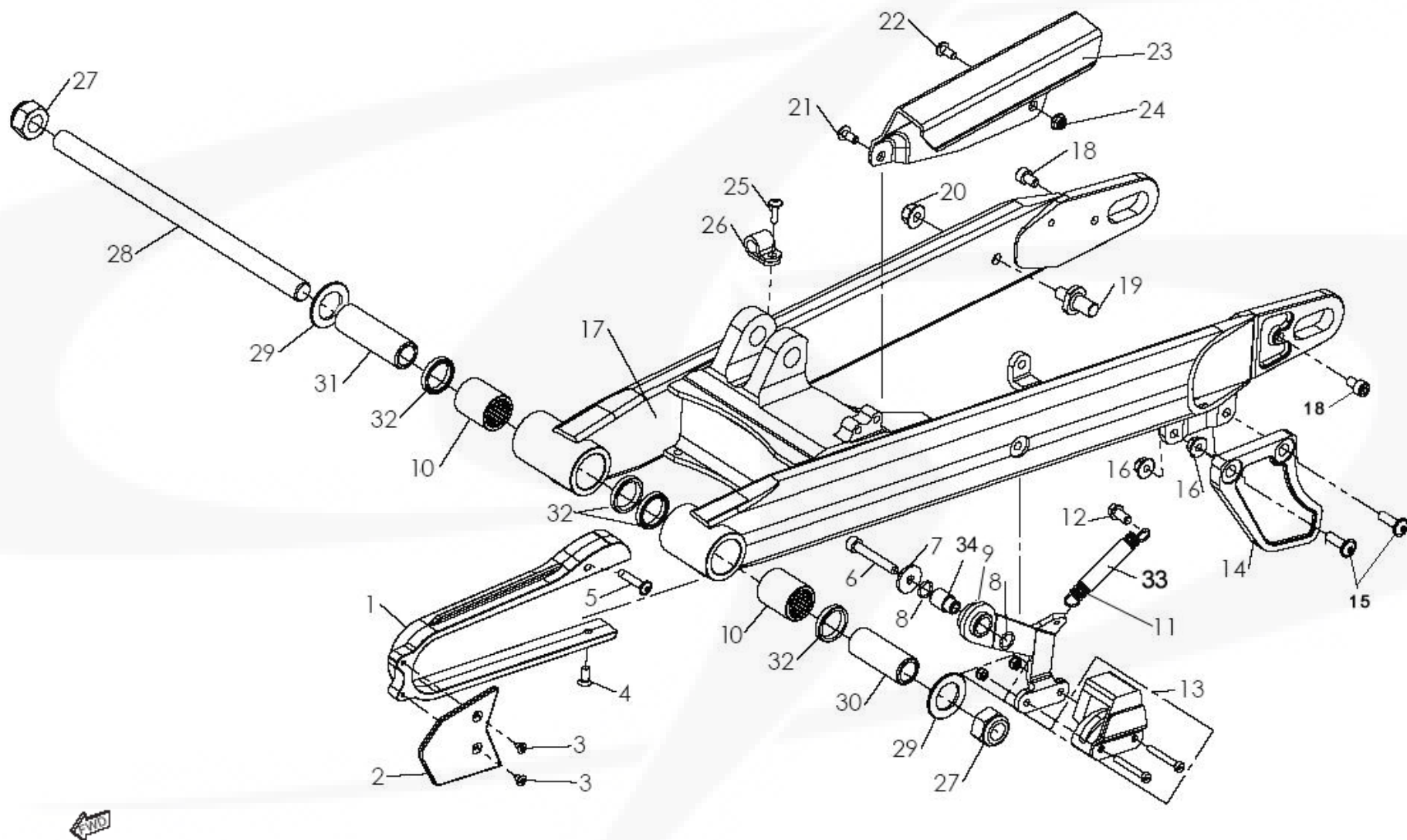



FIG. 21 - BRAS OSCILLANT / SWINGARM / BASCULANTE

N°	REF.	FRANÇAIS	ENGLISH	ESPAÑOL	QTY
1	S10B-20304-00-00	PATIN DE CHAÎNE	SEAL, CHAIN GUARD	PATÍN DE CADENA	1
2	S10B-80801-00-00	PROTECTION PIGNON	COVER, SPROCKET DRIVE	PROTECTOR PIÑÓN	1
3	9VSPA0-35013-NO	VIS PROTECTION PIGNON	SCREW, SPROCKET DRIVE COVER	TORNILLO PROTECTOR PIÑÓN	2
4	9VSTA-05016-00	VIS PATIN DE CHAÎNE INFÉRIEURE	SCREW, CHAIN GUARD SEAL LOWER	TORNILLO PATÍN DE CADENA INFERIOR	1
5	9BHGE-05030-NO	VIS PATIN DE CHAÎNE	SCREW, CHAIN GUARD SEAL	TORNILLO PATÍN DE CADENA	1
6	91317-06035-00	VIS TENDEUR DE CHAÎNE	SCREW, CHAIN PULLER	TORNILLO TENSOR DE CADENA	1
7	9ROFR-06020-00	RONDILLE TENDEUR DE CHAÎNE	WASHER, CHAIN PULLER	ARANDELA TENSOR DE CADENA	1
8	9JTO-01209-00	JOINT TORIQUE	O-RING	TÓRICA	2
9	S10B-20303-00-00	PATTE TENDEUR DE CHAÎNE	PULLER, CHAIN	TENSOR DE CADENA	1
10	9007H-K2030-00	ROULEMENT BRAS OSCILLANT	BEARING, REAR SWINGARM	COJINETE BASCULANTE	2
11	S1A-20307-00-00	RESSORT TENDEUR DE CHAÎNE	SPRING, CHAIN PULLER	MUELLE TENSOR DE CADENA	1
12	95027-06012-00	VIS RESSORT TENDEUR	SCREW, PULLER SPRING	TORNILLO MUELLE TENSOR	1
13	S1A-20304-00-00	PATIN TENDEUR DE CHAÎNE	SKID, CHAIN PULLER	PATÍN TENSOR DE CADENA	1
14	38V-22199-00-00	PROTÈGE COURONNE	PROTECTIVE PLATE, DRIVEN SPROCKET	PROTECTOR CORONA	1
15	95827-06016-00	VIS PROTÈGE COURONNE	SCREW, PROTECTIVE PLATE	TORNILLO PROTECTOR CORONA	2
16	95617-06100-00	ECROU PROTÈGE COURONNE	NUT, PROTECTIVE PLATE	TUERCA PROTECTOR CORONA	2
17	S10B-20301-00-10	BRAS OSCILLANT	ARM, SWINGING REAR	BASCULANTE	1
18	9CHGO-06012-00	VIS RÉGLAGE ESCARGOT	SCREW, ECCENTRIC STOP	TORNILLO AJUSTE EXCÉNTRICA	2
19	S10B-20306-00-00	VIS BUTÉE ÉTRIER ARRIÈRE	STOP, REAR BRAKE CALLIPER	TORNILLO TOPE PINZA TRASERA	1
20	90185-08169-00	ECROU BUTÉE ÉTRIER ARRIÈRE	NUT, REAR CALLIPER STOP	TUERCA TOPE PINZA TRASERA	1
21	9BHGE-05012-NO	VIS CARTER CHAÎNE	SCREW, CHAIN COVER	TORNILLO PROTECTOR CADENA	1
22	9BHGE-05012-NO	VIS CARTER CHAÎNE	SCREW, CHAIN COVER	TORNILLO PROTECTOR CADENA	1
23	S10B-20304-00-00	CARTER CHAÎNE	COVER, CHAIN	PROTECTOR CADENA	1
24	95617-05100-00	ECROU CARTER CHAÎNE	NUT, CHAIN COVER	TUERCA PROTECTOR CADENA	1
25	9VSAU-48016-00	VIS AUTO TARAUDEUSE	SELF-TAPPING SCREW	TORNILLO AUTO ATERRAJADORA	1
26	90008-42812-00	CLIP DURIT FREIN ARRIÈRE	HOLDER, BRAKE HOSE	CLIP LATIGUILLO FRENO TRASERO	1
27	9EC08-14000-00	ECROU AXE BRAS OSCILLANT	NUT, REAR SWINGARM AXLE	TUERCA EJE BASCULANTE	2
28	S10B-20302-00-00	AXE BRAS OSCILLANT	AXLE, REAR ARM	EJE BASCULANTE	1
29	9RONY-20033-00	RONDILLE NYLON	NYLON WASHER	ARANDELA NYLON	2
30	9E051-14020-00	ENTRETOISE INTERNE BAGUE GAUCHE	SPACER, REAR ARM AXLE LEFT SIDE	CASQUILLO ANILLO IZQUIERDO	1
31	9E063-14020-00	ENTRETOISE INTERNE BAGUE DROITE	SPACER, REAR ARM AXLE RIGHT SIDE	CASQUILLO ANILLO DERECHO	1
32	9SP20-02604-00	JOINT À LÈVRE	OIL SEAL	JUNTA ESTANQUEIDAD	4
33	9DU10-11030-00	GAINÉ ISOLANTE RESSORT TENDEUR DE CHAÎNE	INSULATING SHEATH, CHAIN PULLER SPRING	FUNDA AISLANTE MUELLE TENSOR DE CADENA	1
34	S10B-20303-ASM	ENTRETOISE TENDEUR DE CHAÎNE	SPACER, CHAIN PULLER	CASQUILLO TENSOR DE CADENA	1



22 – BOITIER FILTRE A AIR / AIR FILTER BOX / CAJA FILTRO

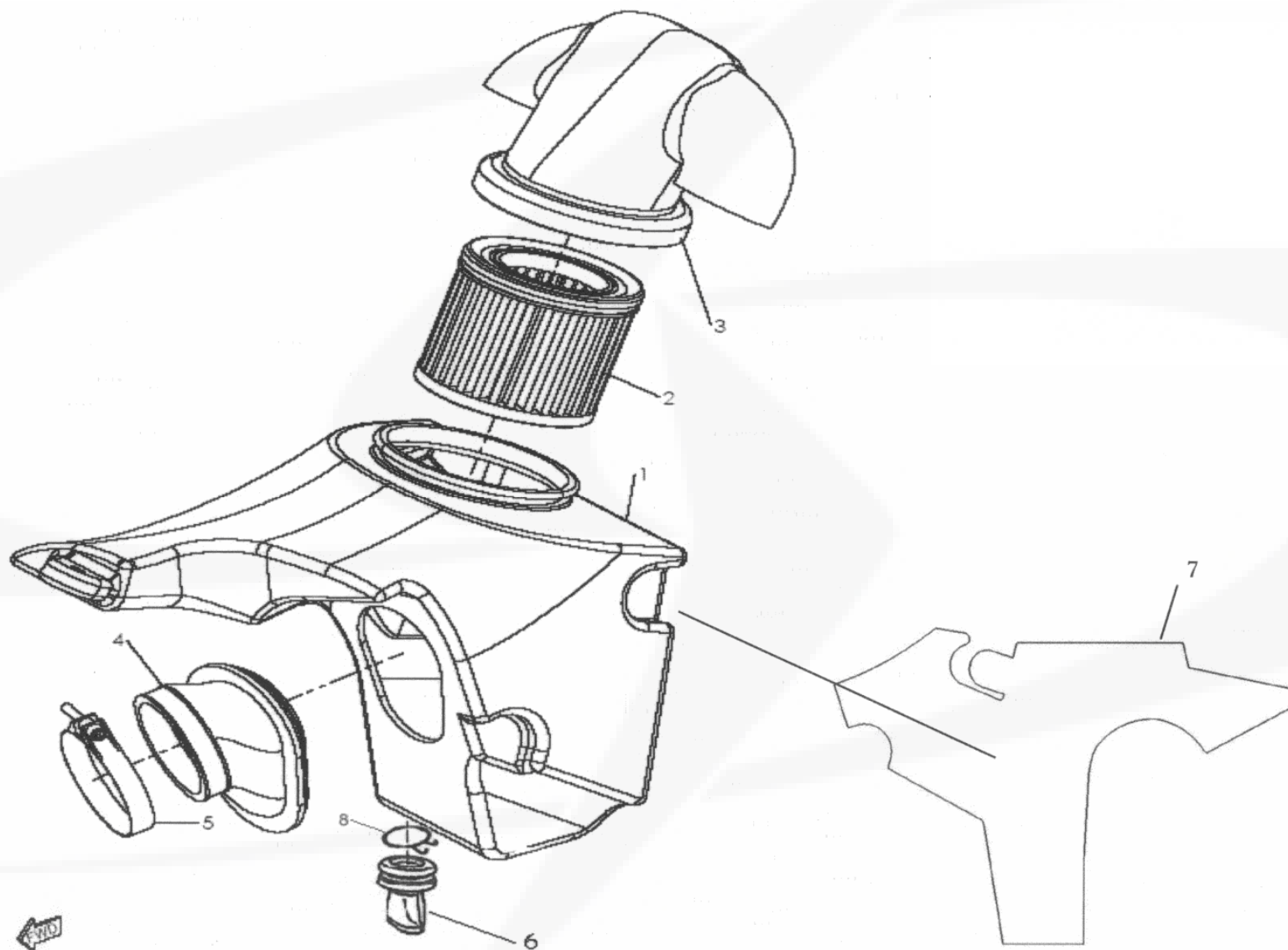



FIG. 22 – BOÎTIER FILTRE À AIR / AIR FILTER BOX / CAJA FILTRO

N°	REF.	FRANÇAIS	ENGLISH	ESPAÑOL	QTY
1	S108-10601-00-00	BOÎTIER FILTRE À AIR	AIR BOX	CAJA FILTRO	1
2	S108-10602-00-00	FILTRE À AIR	FILTER ELEMENT	FILTRO AIRE	1
3	S108-10608-00-00	CAPUCHON BOÎTIER FILTRE	CAP, AIR BOX	CAPUCHÓN CAJA FILTRO	1
4	S108-10607-00-00	MANCHON BOÎTIER FILTRE	SLEEVE, AIR BOX	GOMA CAJA FILTRO	1
5	90450-47001-00	COLLIER SERFLEX	LOCKING COLLAR, AIR CLEANER BOX SLEEVE	ABRAZADERA COBRA GOMA CAJA FILTRO	1
6*	S108-10606-00-00	BOUCHON ÉVACUATION	DRAIN PIPE	TAPÓN EVACUACIÓN	1
7	S108-80809-00-00	AUTOCOLLANT ISOLANT	INSULATING SHEET SELF-ADHESIVE	ADHESIVO AISLANTE	1
8*	S108-10605-00-00	CLIP	CLIP, DRAIN PIPE	CLIP	1
9	S10C-10730-00-05	KIT NETTOYAGE FILTRE À AIR	KIT FILTER ELEMENT CLEANING	KIT LIMPIEZA FILTRO AIRE	1

\* INCLUS DANS BOÎTIER FILTRE À AIR / INCLUDED IN AIR BOX / INCLUIDO EN CAJA FILTRO



23 – COUDE D'ÉCHAPPEMENT / EXHAUST PIPE / TUBO ESCAPE

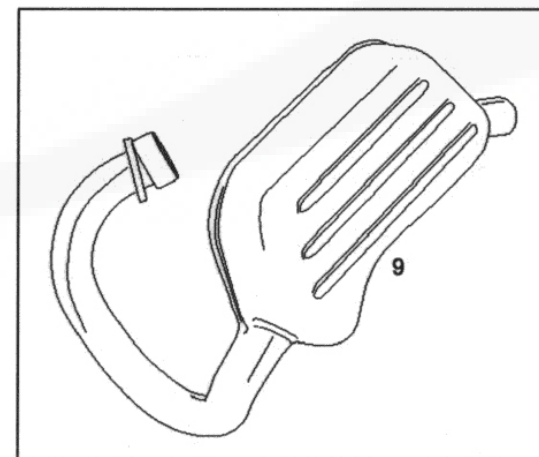
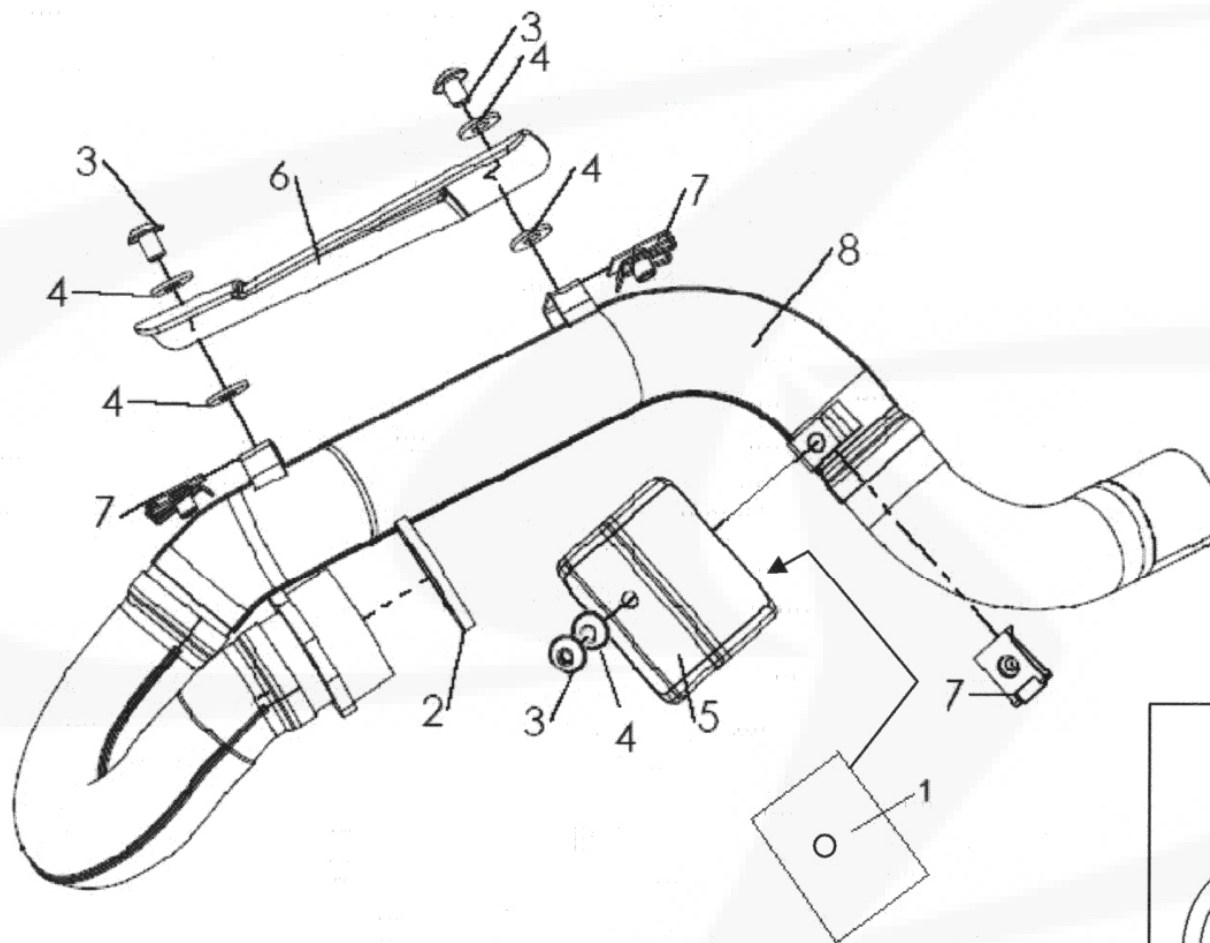



FIG. 23 – COUDE D'ÉCHAPPEMENT / EXHAUST PIPE / TUBO ESCAPE

N°	REF.	FRANÇAIS	ENGLISH	ESPAÑOL	QTY
1*	S10B-80811-00-00	ADHÉSIF ISOLANT	INSULATING SHEET, SELF-ADHESIVE	ADHESIVO AISLANTE	1
2	5NL-14613-00-00	JOINT TUBE ÉCHAPPEMENT	SEAL, EXHAUST PIPE	JUNTA TUBO ESCAPE	1
3*	9BHCE-06012-00	VIS PROTECTION	SCREW, PROTECTIVE PLATE	TORNILLO PLACA PROTECTION	3
4*	9ROAN-06012-02	RONDILLE	WASHER	ARANDELA	5
5*	S10B-80803-00-00	PLAQUE PROTECTION CARBURATEUR	PROTECTIVE PLATE, CARBURETTOR	PLACA PROTECCIÓN CARBURADOR	1
6*	S10B-80802-00-00	PLAQUE PROTECTION	PROTECTIVE PLATE	PLACA PROTECCIÓN	1
7*	9CE06-15822-00	CLIP ÉCROU	NUT CLIP	GRAPA TUERCA	3
8	S10B-10805-00-00	TUBE ÉCHAPPEMENT	EXHAUST PIPE	TUBO ESCAPE	1
9	S10B-10801-00-00	TUBE ÉCHAPPEMENT EURO3	EXHAUST PIPE EURO3	TUBO ESCAPE EURO3	1

\* INCLUS DANS TUBE ÉCHAPPEMENT OFF ROAD / INCLUDED IN EXHAUST PIPE, OFF-ROAD / INCLUIDO EN TUBO ESCAPE OFF-ROAD



## 24 – SILENCIEUX / MUFFLER / SILENCIOSO

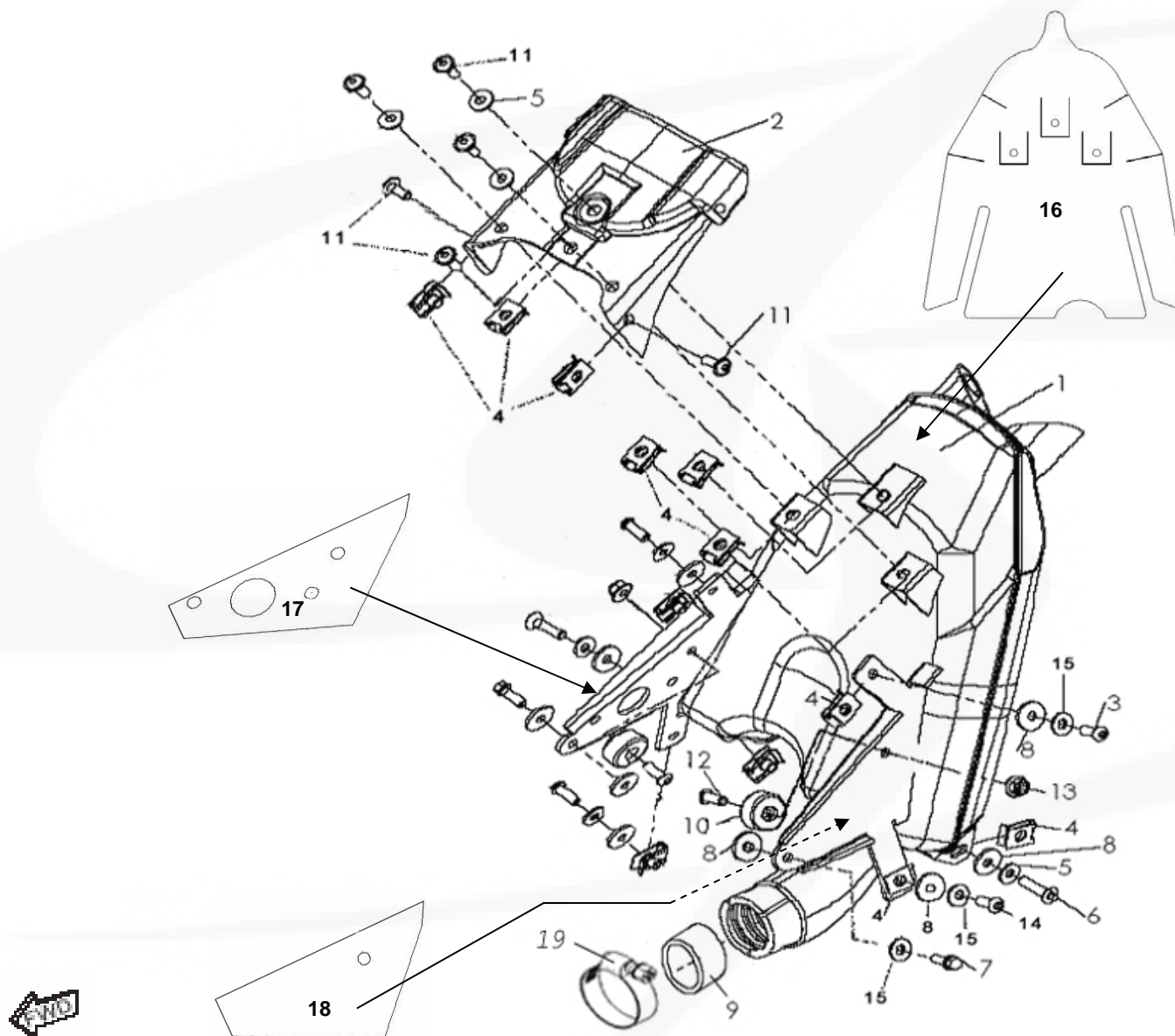



FIG. 24 – SILENCIEUX / MUFFLER / SILENCIOSO

N°	REF.	FRANÇAIS	ENGLISH	ESPAÑOL	QTY
1	S10B-10803-00-00	SILENCIEUX	MUFFLER	SILENCIOSO	1
2	S10B-80303-00-00	SUPPORT GARDE-BOUE ARRIÈRE	BRACKET, REAR FENDER	SOPORTE GUARDABARROS TRASERO	1
3	9BHCO-06020-00	VIS FIXATION SILENCIEUX SUPÉRIEURE	SCREW, MUFFLER ATTACHING UPPER	TORNILLO FIJACIÓN SILENCIOSO SUPERIOR	2
4*	9CE06-15822-00	CLIP ÉCROU	NUT CLIP	GRAPA TUERCA	12
5	9ROAN-06012-00	RONDELLE ANTI-CALORIQUE (FINE)	WASHER, (SLIM) HEAT PROTECTING	ARANDELA AISLANTE AGUARDIENTE	5
6	9FHCO-06025-00	VIS FIXATION SILENCIEUX INFÉRIEURE	SCREW, MUFFLER ATTACHING LOWER	TORNILLO FIJACIÓN SILENCIOSO INFERIOR	2
7	9BHCE-06016-00	VIS FIXATION SILENCIEUX AVANT	SCREW, MUFFLER ATTACHING FORWARD	TORNILLO FIJACIÓN SILENCIOSO DELANTE	2
8	9ROAN-06020-00	RONDELLE ANTI-CALORIQUE	WASHER, HEAT PROTECTING	ARANDELA AISLANTE	8
9*	9JTGR-03935-20	JOINT GRAPHITE	GRAPHITE JOINT, MUFFLER	JUNTA GRAFITO	1
10	S1A-80206-00-00	SILENTBLOC	SILENTBLOCK	SILENTBLOC	2
11	9BHCE-06016-00	VIS GARDE-BOUE ARRIÈRE ET SUPPORT	SCREW, REAR FENDER AND BRACKET	TORNILLO GUARDABARROS TRASERO Y SOPORTE	6
12	91317-06016-00	VIS SILENTBLOC	SCREW, SILENT BLOCK	TORNILLO SILENTBLOC	2
13	95704-06500-00	ECROU SILENTBLOC	NUT, SILENT BLOCK	TUERCA SILENTBLOC	2
14	9BHCE-06020-00	VIS FIXATION PATTE SILENCIEUX INFÉRIEURE	SCREW, MUFFLER ATTACHING PLATE LOWER	TORNILLO FIJACIÓN SILENCIOSO INFERIOR	2
15	9ROAN-06012-02	RONDELLE ANTI-CALORIQUE ÉPAISSE	WASHER, (THICK) HEAT PROTECTING	ARANDELA AISLANTE ESPESA	6
16*	S10B-80812-00-00	ADHÉSIF ISOLANT SILENCIEUX	INSULATING SHEET SELF-ADHESIVE, MUFFLER	ADHESIVO AISLANTE SILENCIOSO	1
17*	S10B-80813-00-00	ADHÉSIF ISOLANT DROIT	INSULATING SHEET SELF-ADHESIVE, RIGHT	ADHESIVO AISLANTE DERECHO	1
18*	S10B-80814-00-00	ADHÉSIF ISOLANT GAUCHE	INSULATING SHEET SELF-ADHESIVE LEFT	ADHESIVO AISLANTE IZQUIERDO	1
19*	9COSE-90046-00	COLLIER SERFLEX	COLLAR, MUFFLER	ABRAZADERA COBRA	1

\* INCLUS DANS SILENCIEUX / INCLUDED IN MUFFLER / INCLUIDO EN SILENCIOSO





## 25 – RESERVOIR / FUEL TANK / DEPÓSITO

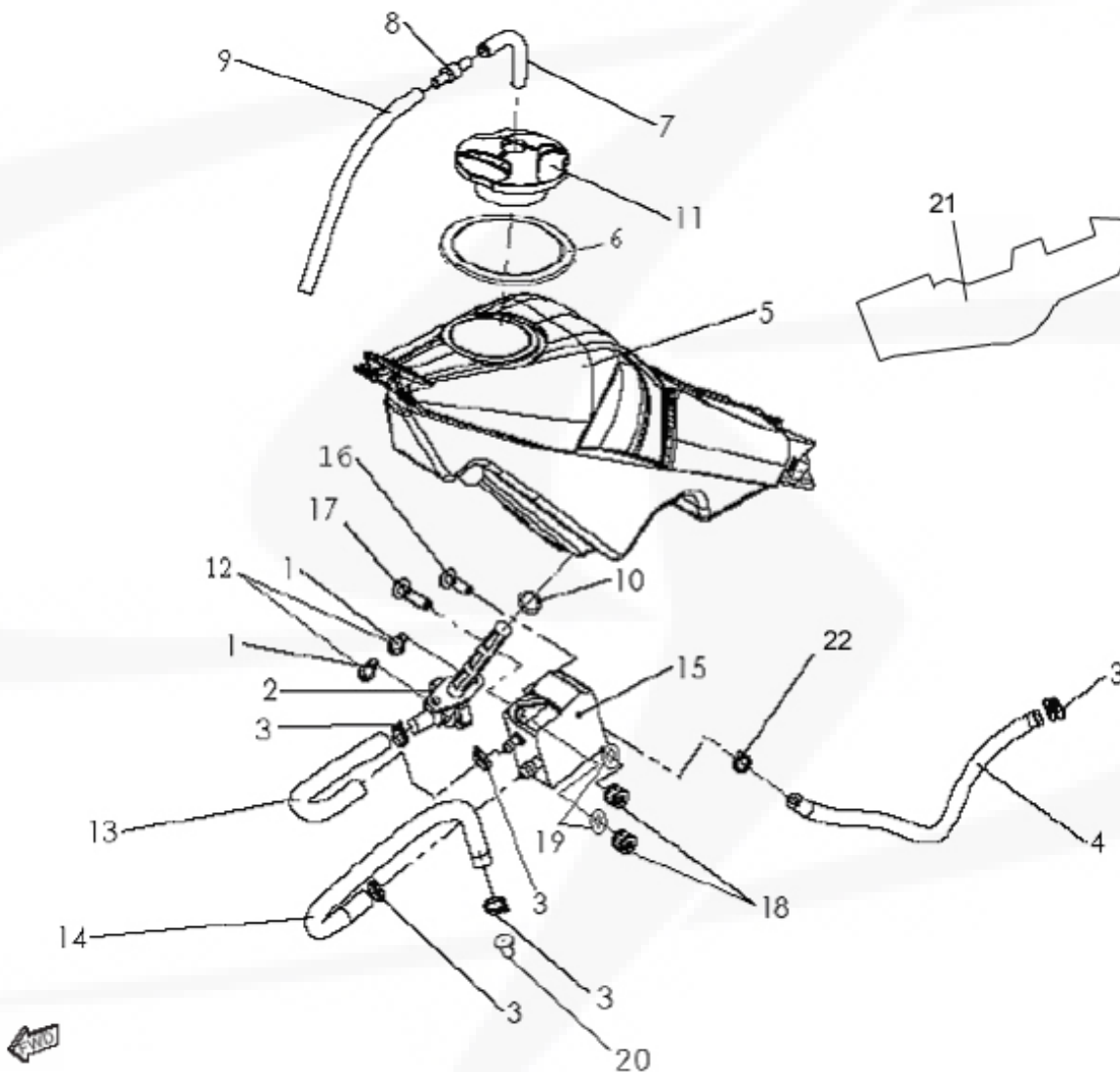



FIG. 25 – RÉSERVOIR / FUEL TANK / DEPÓSITO

N°	REF.	FRANÇAIS	ENGLISH	ESPAÑOL	QTY
1	9BHCO-06012-00	VIS ROBINET	SCREW, TAP	TORNILLO GRIFO	2
2	S1A-80203-00-00	ROBINET RÉSERVOIR	FUEL TAP ASSY	GRIFO GASOLINA	1
3	9CLDU-11000-00	CLIP DURIT	CLIP, HOSE	CLIP TUBO	5
4	9DU05-11460-00	DURIT ESSENCE 1	FUEL HOSE 1	TUBO GASOLINA 1	1
5	S10B-80201-00-00	RÉSERVOIR	FUEL TANK ASSY	DEPÓSITO	1
6**	S10B-80204-00-00	JOINT BOUCHON RÉSERVOIR	SEAL, FUEL TANK CAP	JUNTA TAPÓN DEPÓSITO	1
7	90445-09100-00	DURIT MISE À L'AIR 1	TANK HOSE 1	TUBO DESVAPORIZADOR 1	1
8	90005-24380-00	CLAPET MISE À L'AIR	PIPE JOINT ASSY	VÁLVULA DESVAPORIZADOR	1
9	90445-09220-00	DURIT MISE À L'AIR 2	TANK HOSE 2	TUBO DESVAPORIZADOR 2	1
10*	9JTTO-02011-00	JOINT TORIQUE ROBINET	O RING, FUEL TAP	TÓRICA DEPÓSITO	1
11	S1A-80202-00-00	BOUCHON RÉSERVOIR	CAP, FUEL TANK	TAPÓN DEPÓSITO	1
12	9ROSC-06010-ZI	RONDELLE ROBINET	WASHER, TAP	ARANDELA GRIFO	2
13	9DU05-11160-00	DURIT ESSENCE 2	FUEL HOSE 2	TUBO GASOLINA 2	1
14	9DU05-11170-00	DURIT ESSENCE 3	FUEL HOSE 3	TUBO GASOLINA 3	1
15	S10B-10705-00-00	POMPE À ESSENCE	FUEL PUMP	BOMBA DE GASOLINA	1
16	9CHCO-06016-00	VIS POMPE SUPÉRIEURE	SCREW, FUEL PUMP UPPER	TORNILLO BOMBA SUPERIOR	1
17	9CHCO-06025-00	VIS POMPE INFÉRIEURE	SCREW, FUEL PUMP LOWER	TORNILLO BOMBA INFERIOR	1
18	9EC08-06000-00	ECROU POMPE	NUT, FUEL PUMP	TUERCA BOMBA	2
19	9ROPL-06019-00	RONDELLE POMPE	WASHER, FUEL PUMP	ARANDELA BOMBA	2
20	S10B-10706-00-00	GICLEUR DÉPRESSION	DEPRESSION JET	CHICLE DEPRESIÓN	1
21	S10C-80813-00-00	ADHÉSIF ISOLANT RÉSERVOIR	INSULATING SHEET SELF-ADHESIVE, FUEL TANK	ADHESIVO AISLANTE DEPÓSITO	1
22	9CORY-25100-NO	COLLIER RISLAN 2.5*100	LOCKING COLLAR 2.5*100	ABRAZADERA 2.5*100	1

\* INCLUS DANS ROBINET RÉSERVOIR / INCLUDED IN FUEL TAP ASSY / INCLUIDO EN GRIFO GASOLINA  
 \*\* INCLUS DANS BOUCHON RÉSERVOIR / INCLUDED IN FUEL TANK CAP / INCLUIDO EN TAPÓN DEPÓSITO



25 bis – RESERVOIR LONG-RIDE / FUEL TANK LONG-RIDE / DEPÓSITO LONG-RIDE

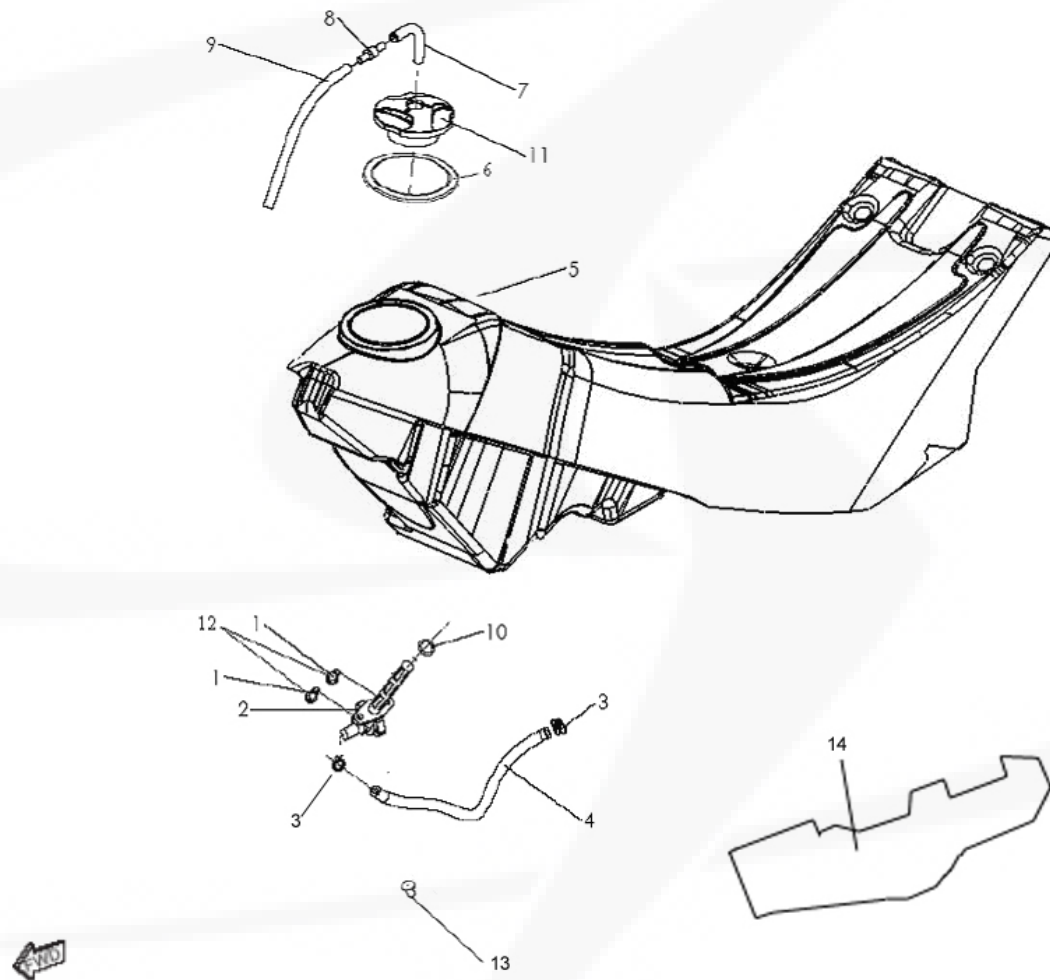



FIG. 25 BIS - RÉSERVOIR LONG-RIDE / FUEL TANK LONG-RIDE / DEPÓSITO LONG-RIDE

N°	REF.	FRANÇAIS	ENGLISH	ESPAÑOL	QTY
1	9BHCO-06012-00	VIS ROBINET	SCREW, TAP	TORNILLO GRIFO	2
2	S13C-80203-00-00	ROBINET RÉSERVOIR	FUEL TAP ASSY	GRIFO GASOLINA	1
3	9CLDU-11000-00	CLIP DURIT	CLIP, HOSE	CLIP TUBO	2
4	9DU05-11250-00	DURIT ESSENCE 1	FUEL HOSE 1	TUBO GASOLINA 1	1
5	S13D-80201-00-00	RÉSERVOIR	FUEL TANK ASSY	DEPÓSITO	1
6**	S10B-80204-00-00	JOINT BOUCHON RÉSERVOIR	SEAL, FUEL TANK CAP	JUNTA TAPÓN DEPÓSITO	1
7	90445-09100-00	DURIT MISE À L'AIR 1	TANK HOSE 1	TUBO DESVAPORIZADOR 1	1
8	90005-24380-00	CLAPET MISE À L'AIR	PIPE JOINT ASSY	VÁLVULA DESVAPORIZADOR	1
9	90445-09220-00	DURIT MISE À L'AIR 2	TANK HOSE 2	TUBO DESVAPORIZADOR 2	1
10*	9JTTO-02011-00	JOINT TORIQUE	O RING	TÓRICA	1
11	S1A-80202-00-00	BOUCHON RÉSERVOIR	CAP, FUEL TANK	TAPÓN DEPÓSITO	1
12	9ROSC-06010-ZI	RONDELLE ROBINET	WASHER, TAP	ARANDELA GRIFO	2
13	S10B-10706-00-00	GICLEUR DÉPRESSION	DEPRESSION JET	CHICLE DEPRESIÓN	1
14	S10C-80813-00-00	ADHÉSIF ISOLANT RÉSERVOIR	INSULATING SHEET SELF-ADHESIVE, FUEL TANK	ADHESIVO AISLANTE DEPÓSITO	1

\* INCLUS DANS ROBINET RÉSERVOIR / INCLUDED IN FUEL TAP ASSY / INCLUIDO EN GRIFO GASOLINA  
 \*\* INCLUS DANS BOUCHON RÉSERVOIR / INCLUDED IN FUEL TANK CAP / INCLUIDO EN TAPÓN DEPÓSITO



## 26 – RADIATEUR / RADIATOR / RADIADOR

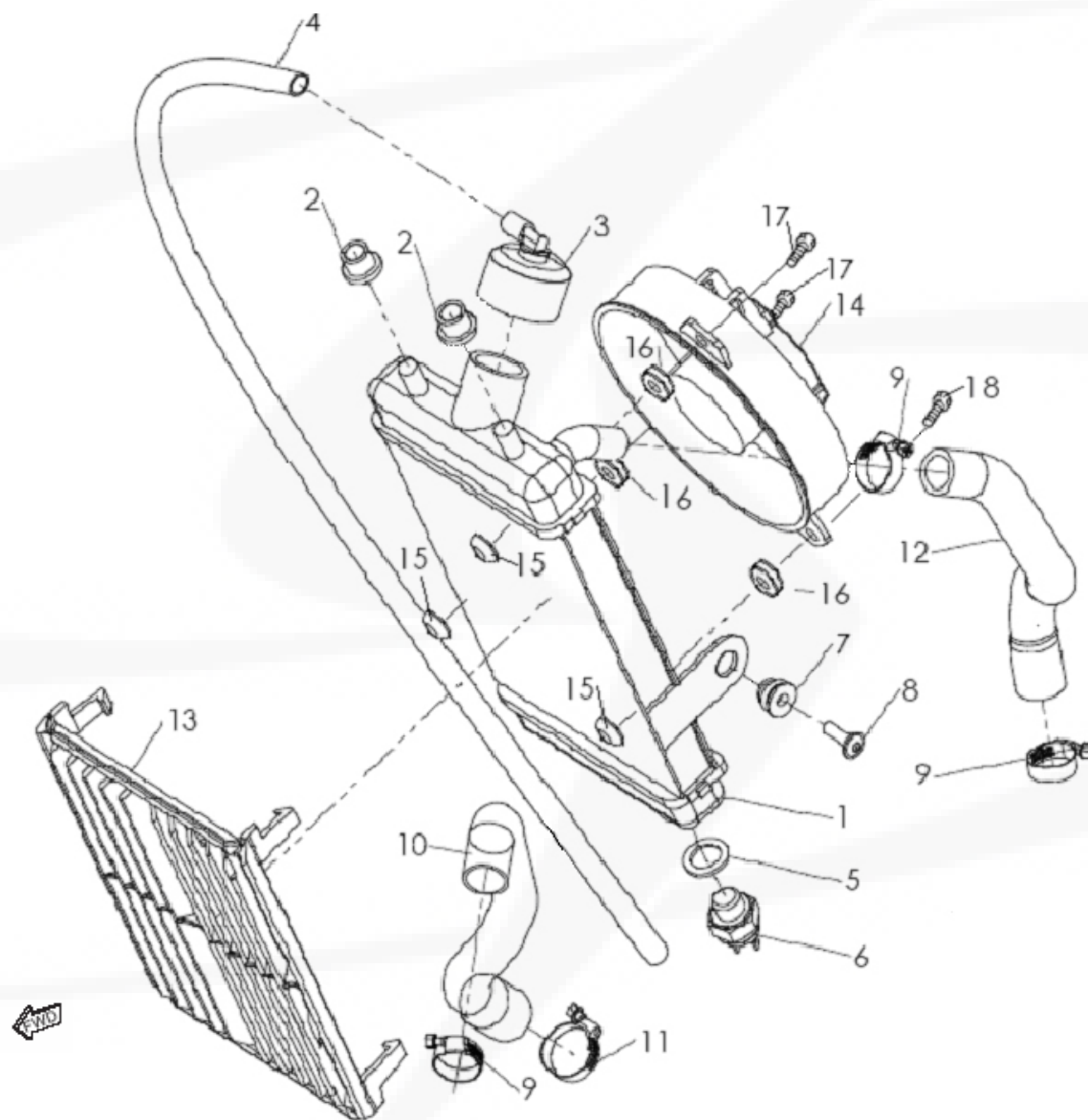



FIG. 26 – RADIATEUR / RADIATOR / RADIADOR

N°	REF.	FRANÇAIS	ENGLISH	ESPAÑOL	QTY
1*	S10B-10401-00-00	RADIATEUR	RADIATOR	RADIADOR	1
2	90008-04171-00	SILENTBLOC	SILENTBLOCK	SILENTBLOC	2
3*	S10B-10404-00-00	BOUCHON RADIATEUR	CAP, RADIATOR	TAPÓN RADIADOR	1
4	9DU05-08700-00	DURIT MISE À L'AIR RADIATEUR	BREATHER, RADIATOR	TUBO DESVAPORIZADOR TAPÓN	1
5*	9ROJT-14020-00	RONDELLE CUIVRE	COPPER WASHER	ARANDELA COBRE	1
6*	S10B-10403-00-00	SONDE TEMPÉRATURE	TEMPERATURE SENSOR	TERMOSTATO	1
7	9ECWE-06000-00	INSERT WELLNUT	INSERT WELLNUT	INSERTO WELLNUT	1
8	95027-06020-00	VIS FIXATION INFÉRIEURE RADIATEUR	SCREW, LOWER ATTACHING RADIATOR	TORNILLO FIJACIÓN INF. RADIADOR	1
9	90450-25037-00	COLLIER SERFLEX	COLLAR	ABRAZADERA COBRA	3
10	9DU16-26125-00	DURIT RADIATEUR / POMPE	HOSE, PUMP / RADIATOR	TUBO RADIADOR / BOMBA	1
11	90450-32015-00	COLLIER SERFLEX	COLLAR	ABRAZADERA COBRA	1
12	9DU16-24140-00	DURIT RADIATEUR / CULASSE	HOSE, HEAD CYLINDER / RADIATOR	TUBO RADIADOR / CULATA	1
13	S10B-10406-00-00	GRILLE RADIATEUR	PROTECTIVE GRID, RADIATOR	REJILLA RADIADOR	1
14*	S10B-10402-00-00	VENTILATEUR	VENTILATOR	VENTILADOR	1
15*	90088-50019-00	ECROU VENTILATEUR	NUT, VENTILATOR ATTACHING	TUERCA VENTILADOR	3
16*	9E006-08016-00	ENTRETOISE VENTILATEUR	SPACER, VENTILATOR	CASQUILLO VENTILADOR	3
17*	90088-30026-NO	VIS FIXATION VENTILATEUR SUP.	SCREW, VENTILATOR ATTACHING UPPER AND RIGHT SIDE	TORNILLO FIJACIÓN VENTILADOR SUP.	2
18*	90088-30056-00	VIS FIXATION VENTILATEUR GAUCHE	SCREW, VENTILATOR ATTACHING LEFT SIDE	TORNILLO FIJACIÓN VENTILADOR IZQUIERDO	1
19	S10B-10400-00-00	RADIATEUR ASSEMBLÉ	RADIATOR ASSY	RADIADOR COMPLETO	1

\* INCLUS DANS RADIATEUR ASSEMBLÉ / INCLUDED IN RADIATOR ASSY / INCLUIDO EN RADIADOR COMPLETO



27 – ROUE AVANT / FRONT WHEEL / RUEDA DELANTERA

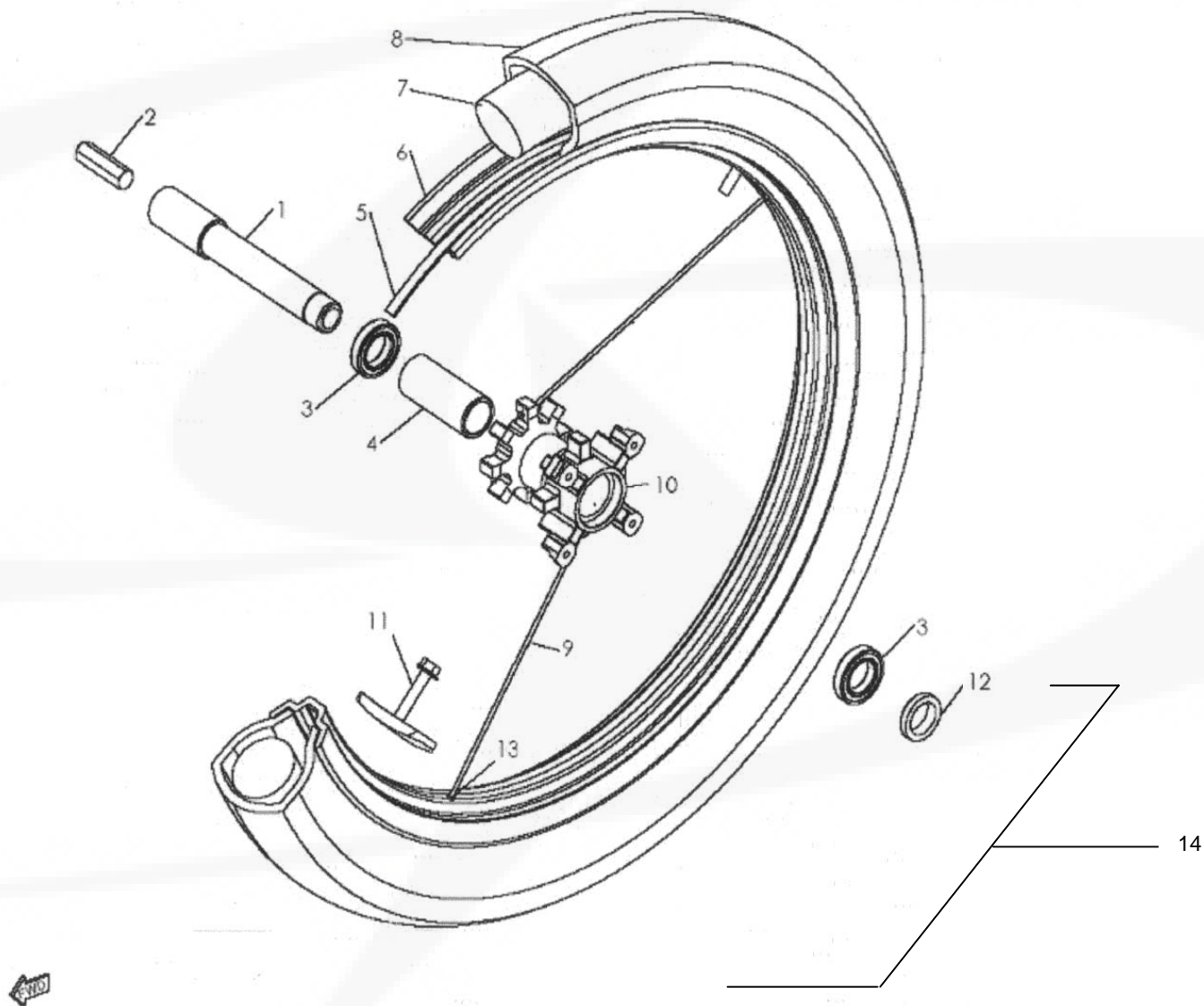



FIG. 27 – ROUE AVANT / FRONT WHEEL / RUEDA DELANTERA

N°	REF.	FRANÇAIS	ENGLISH	ESPAÑOL	QTY
1	S10B-50302-00-00	AXE ROUE AVANT	AXLE, FRONT WHEEL	EJE RUEDA DELANTERA	1
2	90004-06330-00	OUTIL DÉMONTAGE	TOOL FOR DISASSEMBLING	HERRAMIENTA DESMONTAJE	1
3*	6131	ROULEMENT	BEARING	COJINETE	2
4*	9E073-25032-00	ENTRETOISE INTERNE MOYEU	SPACER, HUB	CASQUILLO CUBO	1
5	90037-25021-00	FOND DE JANTE	BAND, RIM	FLAP LLANTA	1
6*	9J160-02132-00	JANTE	RIM	LLANTA	1
7	S3A-50104-00-00	CHAMBRE À AIR 2.75x21	TUBE, TIRE 2.75x21	CÁMARA 2.75x21	1
8	S3A-50103-00-00	PNEU 3.00x21	TIRE 3.00x21	NEUMÁTICO 3.00x21	1
9*	9RAY0-03257-00	RAYON	SPOKE SET	RADIO	32
10*	S10B-50301-00-00	MOYEU	HUB	CUBO	1
11	S1A-50102-00-00	GRIPSTER	RIM LOCK	AGARRE CUBIERTA	1
12	9E009-25035-00	ENTRETOISE GAUCHE	SPACER, LEFT	CASQUILLO IZQUIERDO	1
13*	9ECRA-03055-01	ECROU RAYON	NUT, SPOKE	TUERCA RADIO	32
14	S10B-50101-AM-00	ROUE AVANT ASSEMBLÉE	FRONT WHEEL ASSY	RUEDA DELANTERA COMPLETA	1

\* INCLUS DANS ROUE AVANT ASSEMBLÉE / INCLUDED IN FRONT WHEEL ASSY / INCLUIDO EN RUEDA DELANTERA COMPLETA





28 – FREIN AVANT / FRONT BRAKE / FRENO DELANTERO

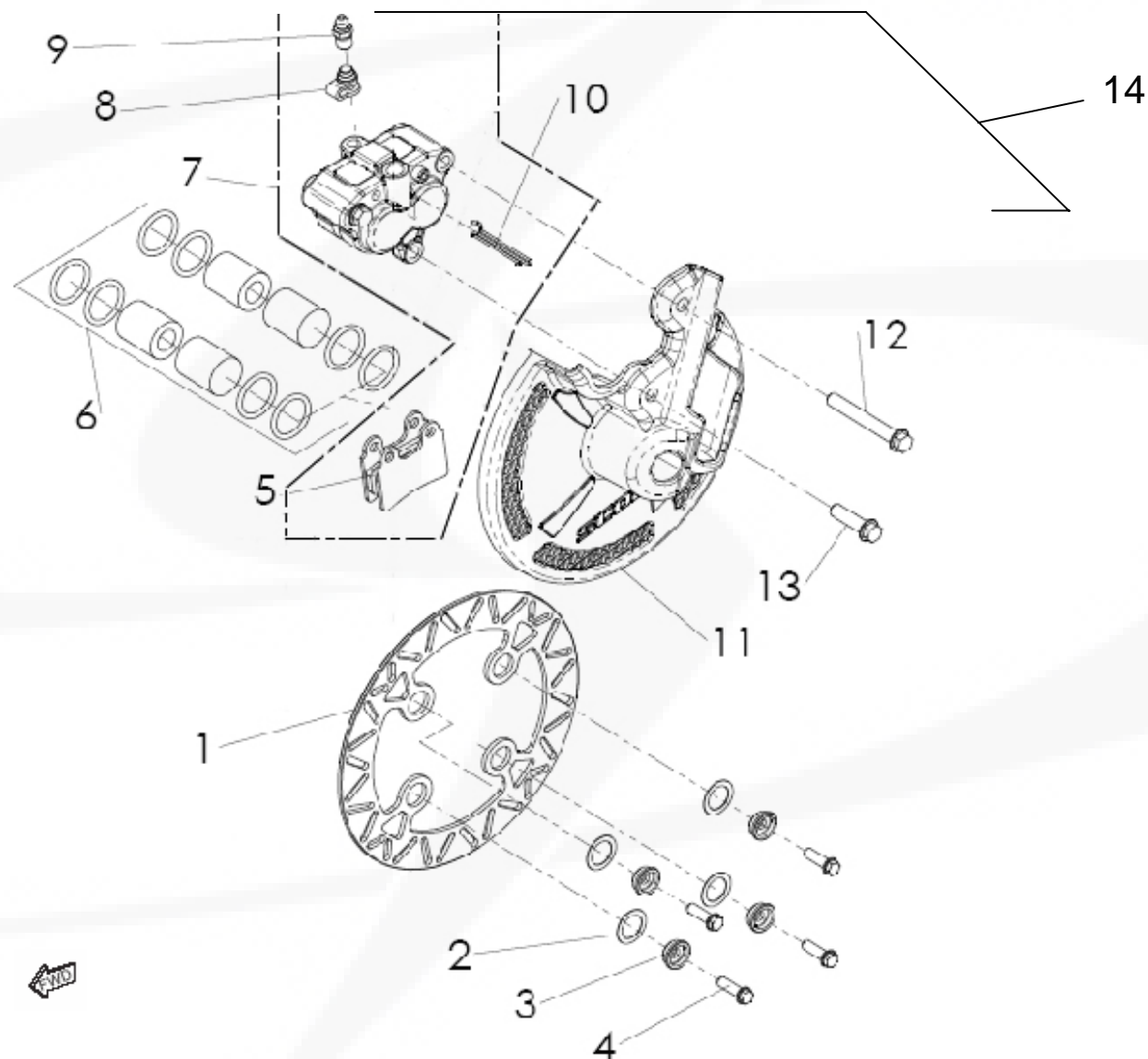



FIG. 28 – FREIN AVANT / FRONT BRAKE / FRENO DELANTERO

N°	REF.	FRANÇAIS	ENGLISH	ESPAÑOL	QTY
1	S10B-40103-00-00	DISQUE FREIN AVANT	DISC, FRONT BRAKE	DISCO FRENO DELANTERO	1
2	9R00N-15022-00	JOINT ENTRETOISE DISQUE AVANT	GASKET, FRONT DISC SPACER	JUNTA CASQUILLO DISCO DELANTERO	4
3	9E006-06018-15	ENTRETOISE DISQUE AVANT	SPACER, FRONT DISC	CASQUILLO DISCO DELANTERO	4
4	95027-06020-00	VIS DISQUE AVANT	SCREW, FRONT DISC	TORNILLO DISCO DELANTERO	4
5*	S10B-40102-00-00	KIT PLAQUETTES FREIN AVANT	PAD KIT, FRONT BRAKE	KIT PASTILLA FRENO DELANTERO	1
6	S2A-40106-00-00	KIT RÉPARATION ÉTRIER AVANT	REPAIR KIT, FRONT BRAKE CALLIPER	KIT REPARACIÓN PINZA FRENO DELANTERO	1
7*	S10B-40101-00-00	ÉTRIER AVANT AVEC KIT PLAQUETTES	CALLIPER, FRONT BRAKE WITH PAD KIT	PINZA FRENO DELANTERO CON PASTILLAS	1
8*	S10B-40208-00-00	BOUCHON VIS DE PURGE ÉTRIER	CAP, CALLIPER BLEED SCREW	TAPÓN TORNILLO PURGA PINZA	1
9*	S1A-40105-00-00	VIS DE PURGE	SCREW, BLEED	TORNILLO PURGA	1
10*	S1A-40206-00-00	GOUPILLE PLAQUETTES AVANT	LOCK PIN, PAD KIT FRONT BRAKE	PASADOR PASTILLAS DELANTERAS	1
11	S10B-80601-00-00	PROTECTION DISQUE AVANT	COVER, FRONT BRAKE DISC	PROTECTOR DISCO DELANTERO	1
12	95027-08060-00	VIS SUPÉRIEURE ÉTRIER	SCREW, CALLIPER UPPER	TORNILLO SUPERIOR PINZA	1
13	95027-08030-00	VIS INFÉRIEURE ÉTRIER	SCREW, CALLIPER LOWER	TORNILLO INFERIOR PINZA	1
14	S10B-40100-00-00	FREIN AVANT ASSEMBLÉ	FRONT BRAKE ASSY	FRENO DELANTERO COMPLETO	1

\* INCLUS DANS FREIN AVANT ASSEMBLÉ AVEC LES PIÈCES DE /  
INCLUDED IN FRONT BRAKE ASSY WITH PARTS OF /  
INCLUIDO EN FRENO DELANTERO COMPLETO CON LAS PIEZAS DE

FIG. 33 MAÎTRE CYLINDRE FREIN AVANT / FRONT BRAKE MASTER CILINDER / BOMBA FRENO DELANTERO :

- S10B-40701-00-00
- S1A-40502-00-00
- S10B-40501-00-00
- S10B-40301-00-00
- S1A-40104-00-00
- 9R0JT-10014-00



## 29 – ROUE ARRIERE / REAR WHEEL / RUEDA TRASERA

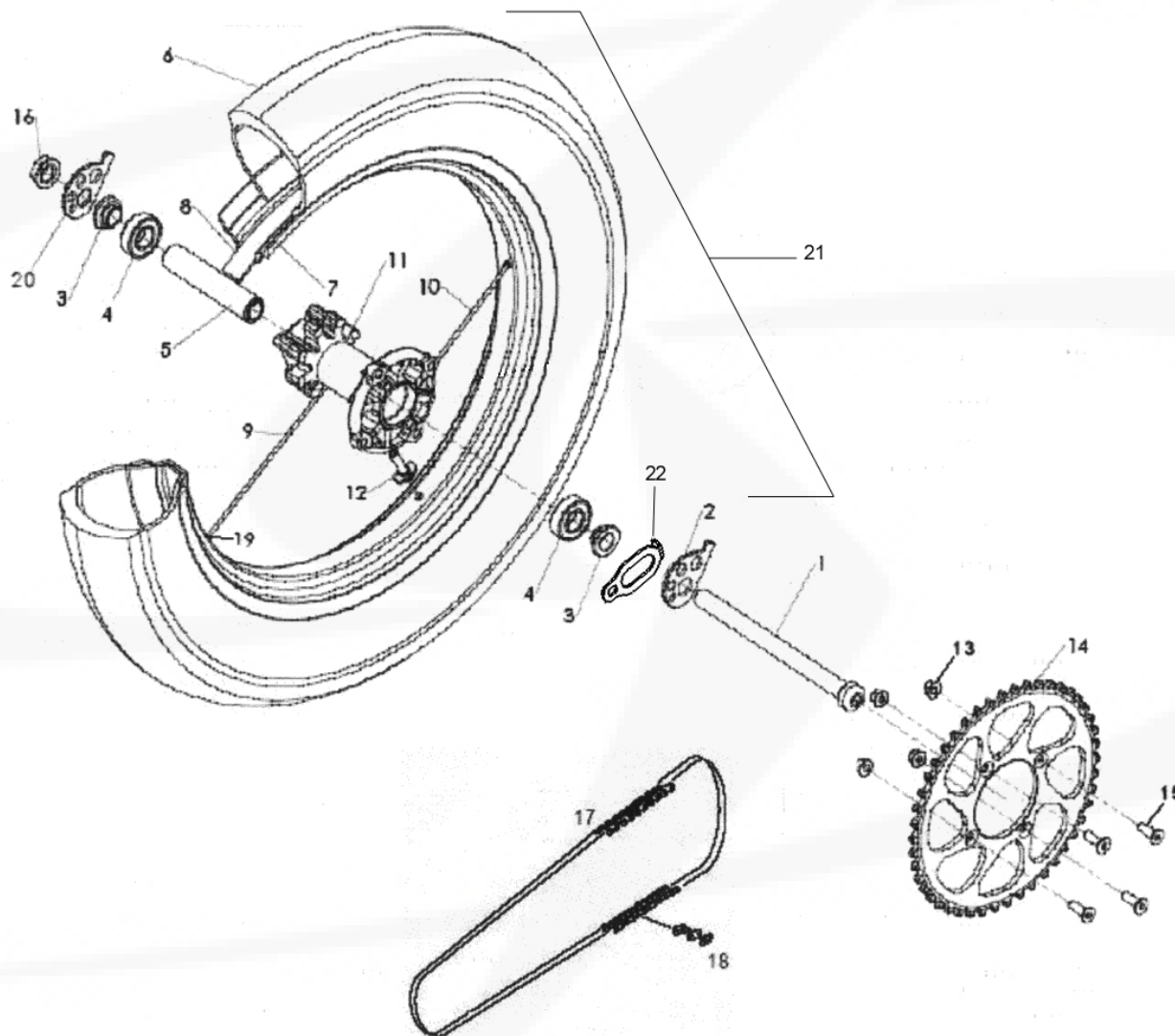



FIG. 29 – ROUE ARRIÈRE / REAR WHEEL / RUEDA TRASERA

N°	REF.	FRANÇAIS	ENGLISH	ESPAÑOL	QTY
1	S1A-50402-00-00	AXE ROUE ARRIÈRE	AXLE, REAR WHEEL	EJE RUEDA TRASERA	1
2	S10B-50403-00-00	ESCARGOT GAUCHE	SAIL CAM ADJUSTER, LEFT	EXCÉNTRICA IZQUIERDA	1
3	9E121-20026-00	ENTRETOISE	SPACER	CASQUILLO	2
4*	93306-00402-00	ROULEMENT	BEARING	COJINETE	2
5*	9E121-20026-00	ENTRETOISE MOYEU	SPACER, RIM	CASQUILLO CUBO	1
6	S2A-50203-00-00	PNEU TUBELESS 4.00X18	TIRE, TUBELESS 4.00X18	NEUMÁTICO TUBELESS 4.00X18	1
7	7073	JANTE	RIM	LLANTA	1
8	90044-34018-01	FOND DE JANTE	BAND, RIM	FONDO DE LLANTA	1
9*	9RAY0-35215-01	RAYON CÔTÉ DROIT	SPOKE SET, RIGHT SIDE	RADIO LADO DERECHO	16
10*	9RAY0-35222-01	RAYON CÔTÉ GAUCHE	SPOKE SET, LEFT SIDE	RADIO LADO IZQUIERDO	16
11*	S10B-50401-00-00	MOYEU	HUB	CUBO	1
12	S2A-50205-00-00	VALVE	AIR VALVE	VÁLVULA	1
13	9EC08-08000-00	ECROU COURONNE	NUT , DRIVEN SPROCKET	TUERCA CORONA	4
14	9C080-00520-48	COURONNE	DRIVEN SPROCKET	CORONA	1
15	9FH00-08025-00	VIS COURONNE	SCREW, DRIVEN SPROCKET	TORNILLO CORONA	4
16	S1A-50405-00-00	ECROU AXE DE ROUE ARRIÈRE	NUT, REAR WHEEL AXLE	TUERCA EJE RUEDA TRASERA	1
17	9CHA5-20103-00	CHAÎNE (103 MAILLONS)	CHAIN (103 LINKS)	CADENA (103 PASOS)	1
18**	9ATRA-52000-00	ATTACHE RAPIDE	CONNECTING LINK	ENGANCHE	1
19*	9ECRA-35070-01	ECROU RAYON	NUT, SPOKE SET	TUERCA RADIO	32
20	S10B-50404-00-00	ESCARGOT DROIT	SAIL CAM ADJUSTER, RIGHT	EXCÉNTRICA DERECHA	1
21	S2A-50201-AM-00	ROUE ARRIÈRE ASSEMBLÉE	REAR WHEEL ASSY	RUEDA TRASERA COMPLETA	1
22	S10C-20308-00-00	PLAQUE RENFORT VIS BUTÉE ESCARGOT	PLATE, REINFORCEMENT ECCENTRIC STOP SCREW	PLACA REFUERZO TORNILLO AJUSTE EXCÉNTRICA	1

\* INCLUS DANS ROUE ARRIÈRE ASSEMBLÉE / INCLUDED IN REAR WHEEL ASSY / INCLUIDO EN RUEDA TRASERA COMPLETA

\*\* INCLUS DANS CHAÎNE / INCLUDED IN CHAIN / INCLUIDO EN CADENA



### 30 – FREIN ARRIERE / REAR BRAKE / FRENO TRASERO

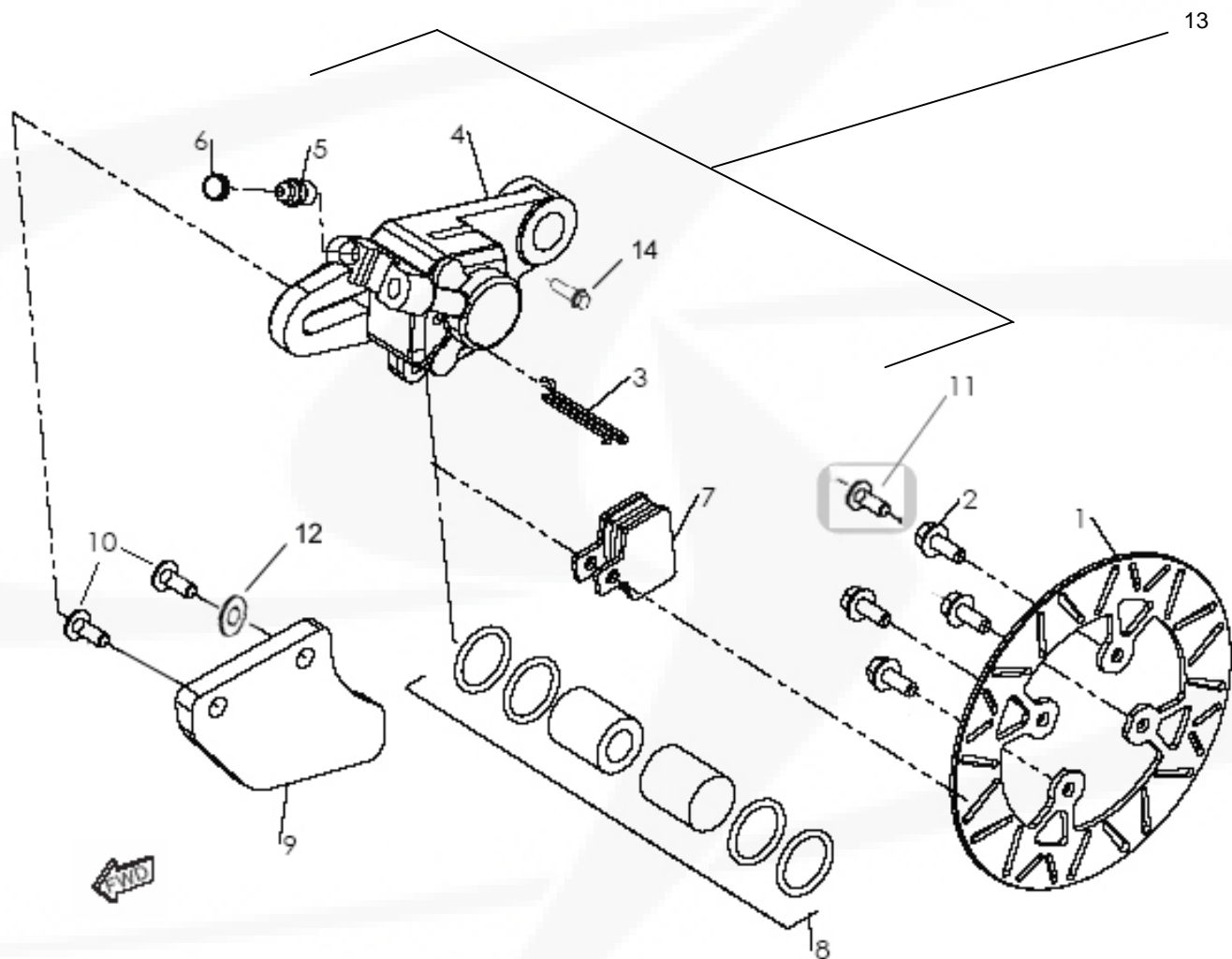



FIG. 30 – FREIN ARRIÈRE / REAR BRAKE / FRENO TRASERO

N°	REF.	FRANÇAIS	ENGLISH	ESPAÑOL	QTY
1	S10B-40203-00-00	DISQUE FREIN ARRIÈRE	DISC, REAR BRAKE	DISCO FRENO TRASERO	1
2	90109-06564-00	VIS	SCREW	TORNILLO	4
3*	S1A-40206-00-00	GOUPILLE PLAQUETTES ARRIÈRE	LOCK PIN, PAD KIT REAR BRAKE	PASADOR PASTILLAS TRASERAS	1
4*	S1A-40201-01-00	ÉTRIER ARRIÈRE AVEC KIT PLAQUETTES	CALLIPER, REAR BRAKE WITH PAD KIT	PINZA FRENO DELANTERO CON PASTILLAS	1
5*	S1A-40207-00-00	VIS DE PURGE	SCREW, BLEED	TORNILLO PURGA	1
6*	S1A-40208-00-00	BOUCHON VIS DE PURGE ÉTRIER	CAP, CALLIPER BLEED SCREW	TAPÓN TORNILLO PURGA PINZA	1
7*	S10B-40202-00-00	KIT PLAQUETTES FREIN ARRIÈRE	PAD KIT, REAR BRAKE	KIT PASTILLA FRENO TRASERO	1
8	S1A-40209-00-00	KIT RÉPARATION ÉTRIER ARRIÈRE	REPAIR KIT, REAR BRAKE CALLIPER	KIT REPARACIÓN PINZA FRENO TRASERO	1
9	S3A-80805-00-00	PROTECTION DISQUE ARRIÈRE	PROTECTIVE PLATE, REAR BRAKE DISC	PROTECTOR DISCO TRASERO	1
10	95827-06016-00	VIS PROTECTION DISQUE	SCREW, PROTECTIVE PLATE	TORNILLO PROTECTOR DISCO	2
11	9BHCE-06020-00	VIS AIMANT COMPTEUR	SCREW, MAGNET OF SPEEDOMETER	TORNILLO IMÁN VELOCÍMETRO	1
12	9ROSC-06010-Z1	RONDELLE PROTECTION DISQUE	WASHER, PROTECTIVE PLATE	ARANDELA PROTECTOR DISCO	1
13	S10B-40200-01-00	FREIN ARRIÈRE ASSEMBLÉ	REAR BRAKE ASSY	FRENO TRASERO COMPLETO	1
14	9CBC0-04016-00	VIS FIXATION CAPTEUR	SCREW, SENSOR FIX	TORNILLO FIJACIÓN SENSOR	1

\* INCLUS DANS FREIN ARRIÈRE ASSEMBLÉ AVEC LES PIÈCES DE /  
INCLUDED IN REAR BRAKE ASSY WITH PARTS OF /  
INCLUIDO EN FRENO TRASERO COMPLETO CON LAS PIEZAS DE

FIG. 35 MAÎTRE CYLINDRE FREIN ARRIÈRE / REAR BRAKE MASTER CILINDER / BOMBA FRENO TRASERO :

- 9R0JT-10014-00
- S1A-40104-00-00
- S10B-40401-00-00
- 9DU05-08130-00
- 9CLDU-08000-00
- S1A-40204-00-00
- S1A-40601-00-00



31 – GUIDON / HANDLEBAR / MANILLAR

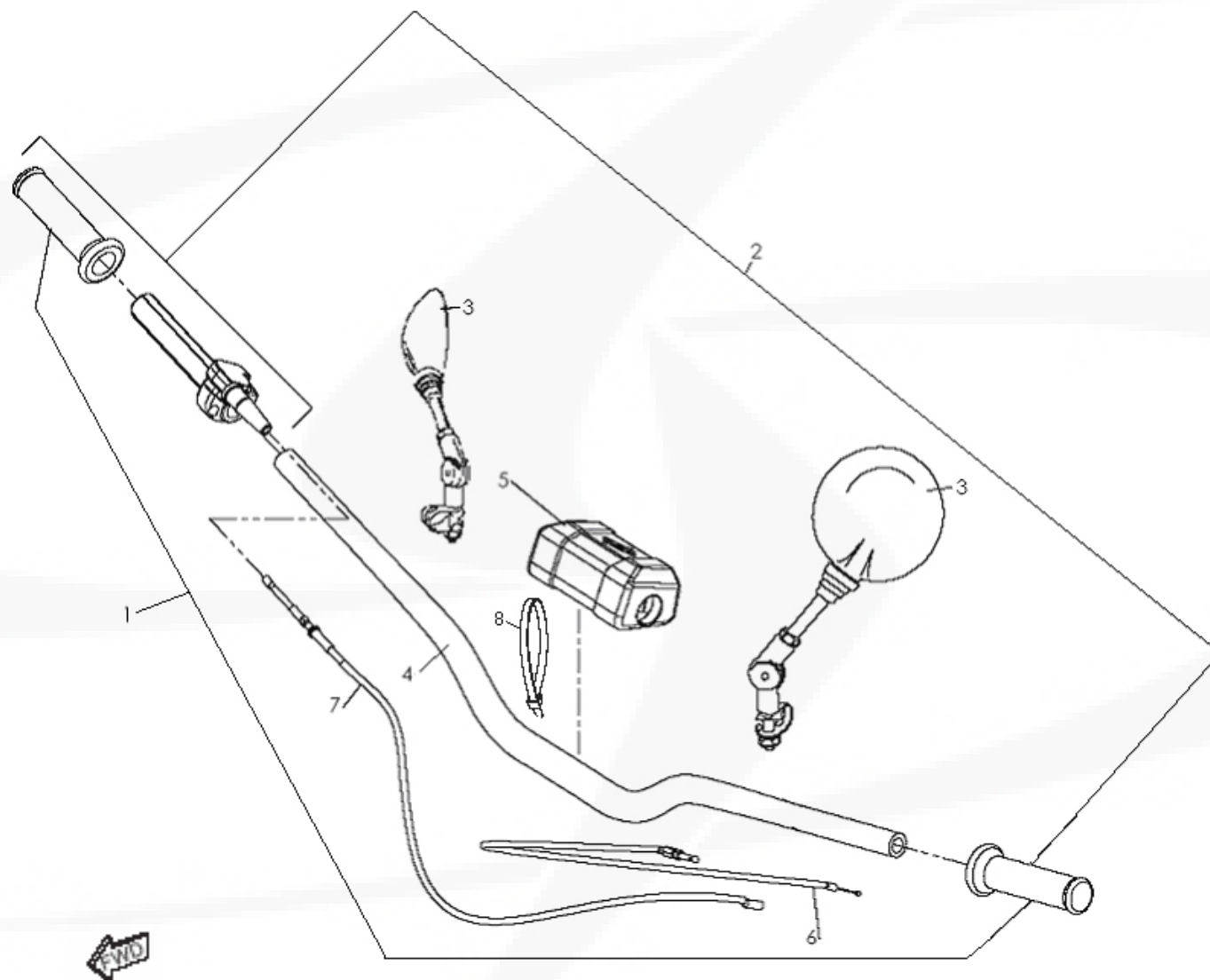



FIG. 31 - GUIDON / HANDLEBAR / MANILLAR

N°	REF.	FRANÇAIS	ENGLISH	ESPAÑOL	QTY
1	S1A-60202-00-00	POIGNÉES	GRIP, HANDLE BAR	EMPUÑADURAS	2
2	S1A-60204-00-00	COMMANDE DE GAZ	THROTTLE AND GRIP ASSY	MANDO GAS	1
3	S3A-60501-00-00	RÉTROVISEURS	REAR VIEW MIRROR ASSY	RETROVISOR	2
4	S10B-60201-00-00	GUIDON	HANDLE BAR	MANILLAR	1
5	S10B-60205-00-00	MOUSSE DE GUIDON	FOAM, HANDLEBAR	ESPUMA MANILLAR	1
6	S10B-60302-00-00	CÂBLE STARTER	STARTER CABLE	CABLE ESTÁRTER	1
7	S10B-60301-00-00	CÂBLE ACCÉLÉRATEUR	CABLE THROTTLE	CABLE DE GAS	1
8	9CORY-48280-NO	COLLIER RISLAN 4.8*280	LOCKING COLLAR 4.8*280	ABRAZADERA 4.8*280	1





### 32 – MAITRE CYLINDRE FREIN AVANT / FRONT BRAKE MASTER CYLINDER / BOMBA FRENO DELANTERO

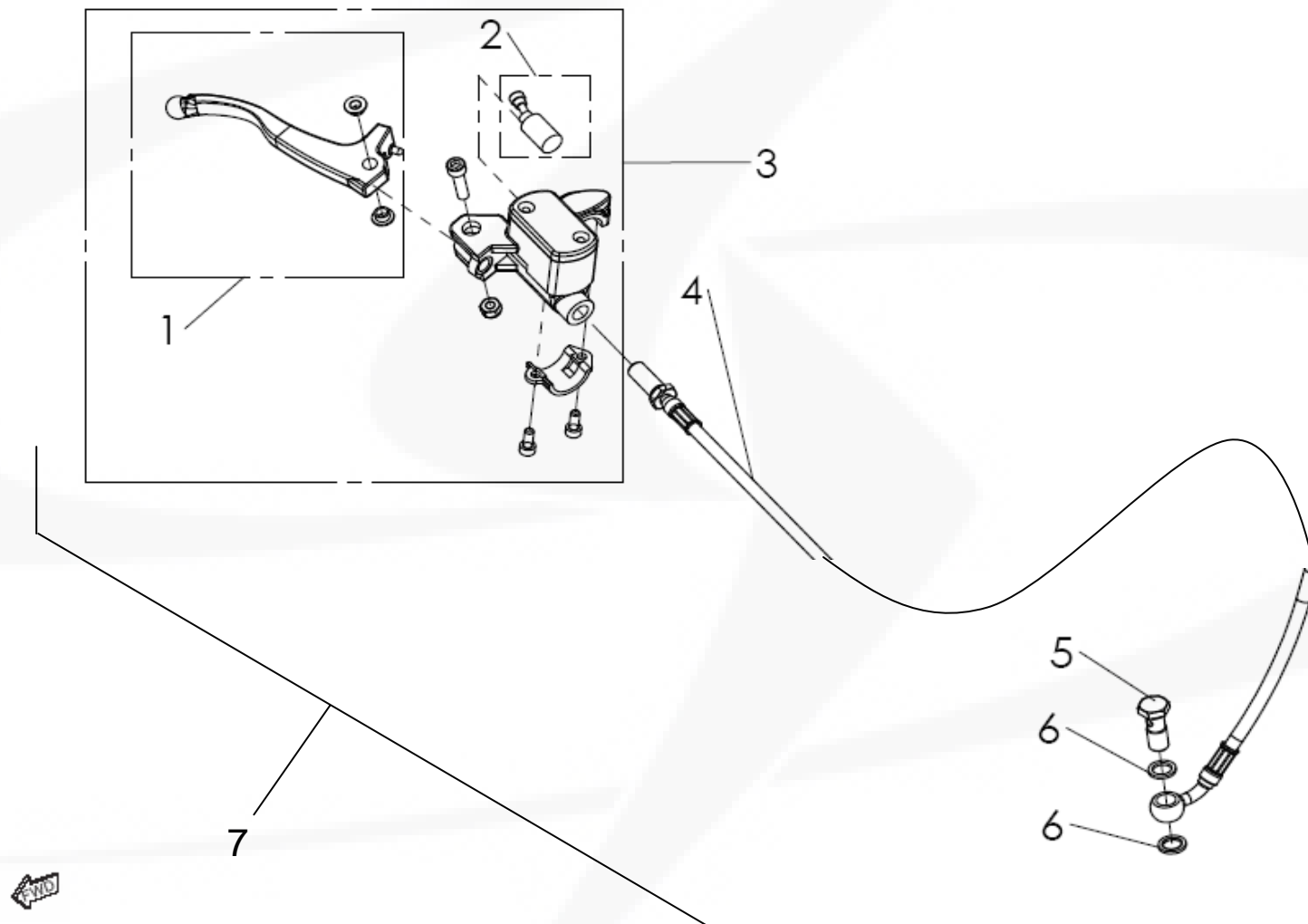



FIG. 32 – MAÎTRE CYLINDRE FREIN AVANT / FRONT BRAKE MASTER CYLINDER / BOMBA FRENO DELANTERO

N°	REF.	FRANÇAIS	ENGLISH	ESPAÑOL	QTY
1*	S10B-40701-00-00	LEVIER FREIN AVANT	LEVER, FRONT BRAKE	MANETA FRENO DELANTERO	1
2*	S1A-40502-00-00	KIT RÉPARATION MAÎTRE CYLINDRE FREIN AVANT	REPAIR KIT, FRONT MASTER CYLINDER ASSEMBLY	KIT REPARACIÓN BOMBA FRENO DELANTERO	1
3*	S10B-40501-00-00	MAÎTRE CYLINDRE FREIN AVANT COMPLET	FRONT MASTER CYLINDER ASSEMBLY	BOMBA FRENO DELANTERO COMPLETO	1
4*	S10B-40301-00-00	DURIT FREIN AVANT	HOSE, FRONT BRAKE	LATIGUILLO FRENO DELANTERO	1
5*	S1A-40104-00-00	VIS RACCORD	SCREW, UNION	TORNILLO CONEXIÓN	1
6*	9ROJT-10014-00	RONDILLE RACCORD	WASHER, UNION SCREW	ARANDELA CONEXIÓN	2
7	S10B-40100-00-00	FREIN AVANT ASSEMBLÉ	FRONT BRAKE ASSY	FRENO DELANTERO COMPLETO	1

\* INCLUS DANS FREIN AVANT ASSEMBLÉ AVEC LES PIÈCES DE /  
INCLUDED IN FRONT BRAKE ASSY WITH PARTS OF /  
INCLUIDO EN FRENO DELANTERO COMPLETO CON PIEZAS DE

FIG. 29 FREIN AVANT / FRONT BRAKE / FRENO DELANTERO :

- S10B-40102-00-00
- S10B-40101-00-00
- S10B-40208-00-00
- S1A-40105-00-00
- S1A-40206-00-00



### 33 – LEVIER D'EMBAYAGE / CLUTCH LEVER / MANETA DE EMBRAGUE

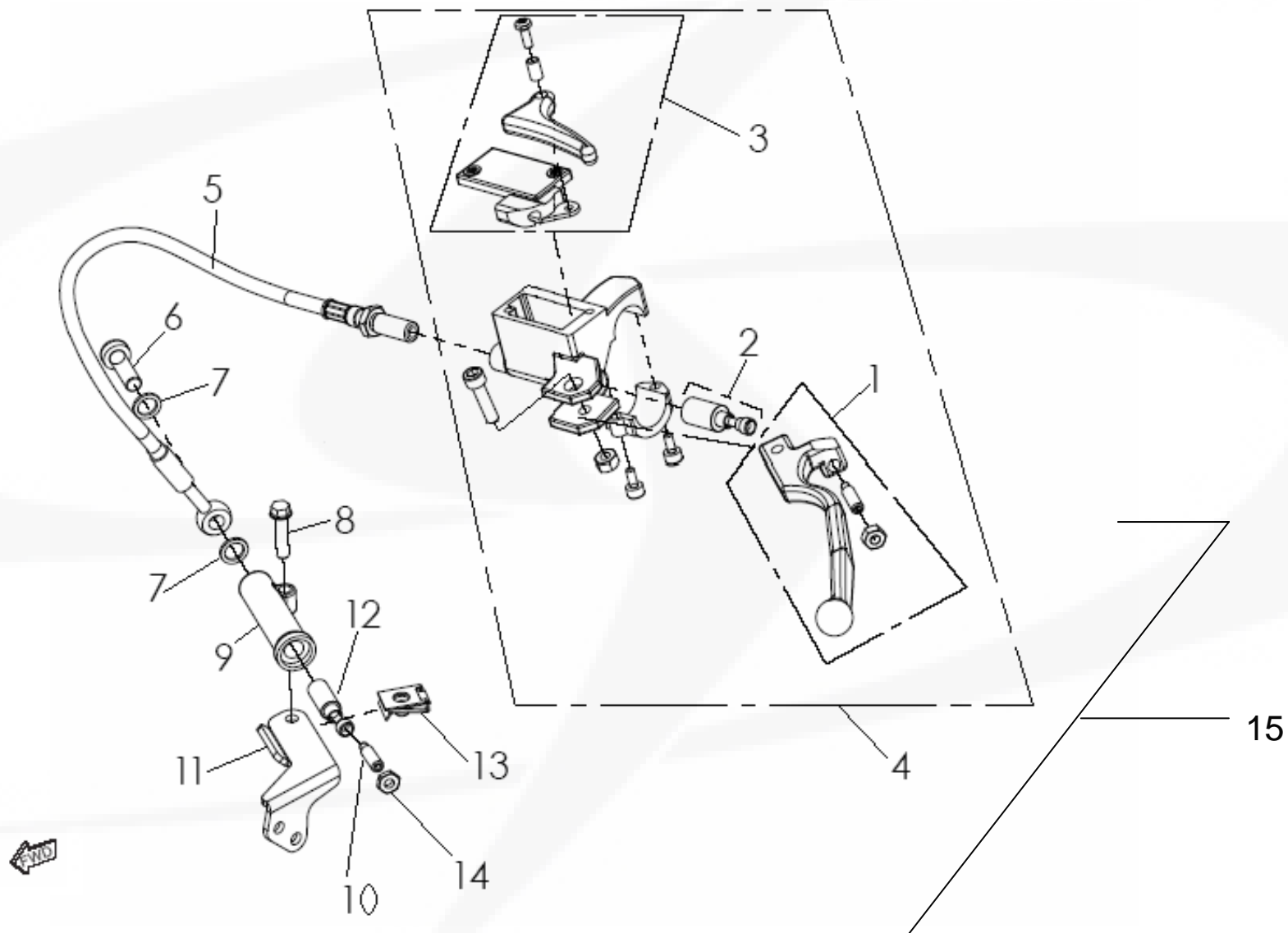



FIG. 33 – LEVIER D'EMBRAYAGE / CLUTCH LEVER / MANETA DE EMBRAGUE

N°	REF.	FRANÇAIS	ENGLISH	ESPAÑOL	QTY
1*	S10B-60401-00-00	LEVIER EMBRAYAGE	CLUTCH LEVER	MANETA EMBRAGUE	1
2	S1A-40502-00-00	KIT RÉPARATION MAÎTRE CYLINDRE EMBAYAGE	REPAIR KIT, CLUTCH MASTER CYLINDER	KIT REPARACIÓN BOMBA EMBRAGUE	1
3*	S10B-60404-00-00	LEVIER STARTER ET COUVERCLE MAÎTRE CYLINDRE	CHOKE LEVER AND COVER MASTER CYLINDER ASSY	MANETA ESTÁRTER Y TAPA BOMBA EMBAGUE	1
4*	S10B-60405-00-00	MAÎTRE CYLINDRE EMBRAYAGE ASSEMBLÉ	CLUTCH MASTER CYLINDER ASSY	BOMBA EMBRAGUE COMPLETEA	1
5*	S10B-60403-00-00	DURIT EMBRAYAGE	HOSE, CLUTCH LEVER	LATIGUILLO EMBRAGUE	1
6*	S1A-40603-00-00	VIS RACCORD	SCREW, UNION	TORNILLO CONEXIÓN	1
7*	9ROJT-10014-00	RONDELLE RACCORD	WASHER, UNION SCREW	ARANDELA CONEXIÓN	2
8	95027-06025-00	VIS RÉCEPTEUR	SCREW, SLAVE CYLINDER	TORNILLO RECEPTOR	1
9*	S10B-60407-00-00	RÉCEPTEUR EMBRAYAGE	SLAVE CYLINDER, CLUTCH	RECEPTOR EMBRAGUE	1
10*	3150B	VIS RÉGLAGE RÉCEPTEUR	SETTING SCREW, PUSH LEVER	TORNILLO AJUSTE RECEPTOR	1
11	S10B-11002-00-00	SUPPORT RÉCEPTEUR EMBRAYAGE	FIXING SLAVE CYLINDER	SOPORTE RECEPTOR EMBRAGUE	1
12	S10B-60406-00-00	KIT RÉPARATION RÉCEPTEUR	REPAIR KIT, CLUTCH SLAVE CYLINDER	KIT REPARACIÓN RECEPTOR	1
13	9CE06-15822-00	CLIP ÉCROU	CLIP NUT	GRAPA TUERCA	1
14*	3150C	ÉCROU RÉGLAGE RÉCEPTEUR	SETTING NUT, PUSH LEVER	TUERCA AJUSTE RECEPTOR	1
15	S10B-60402-00-00	POIGNÉE EMBRAYAGE ASSEMBLÉE	CLUTCH PUMP ASSY	MANETA EMBRAGUE COMPLETEA	1

\* INCLUS DANS LIGNE EMBRAYAGE ASSEMBLÉE / INCLUDED IN CLUTCH LINE ASSY / INCLUIDO EN EMBRAGUE COMPLETO



### 34 – MAITRE CYLINDRE FREIN ARRIERE / REAR BRAKE MASTER CYLINDER / BOMBA FRENO TRASERO

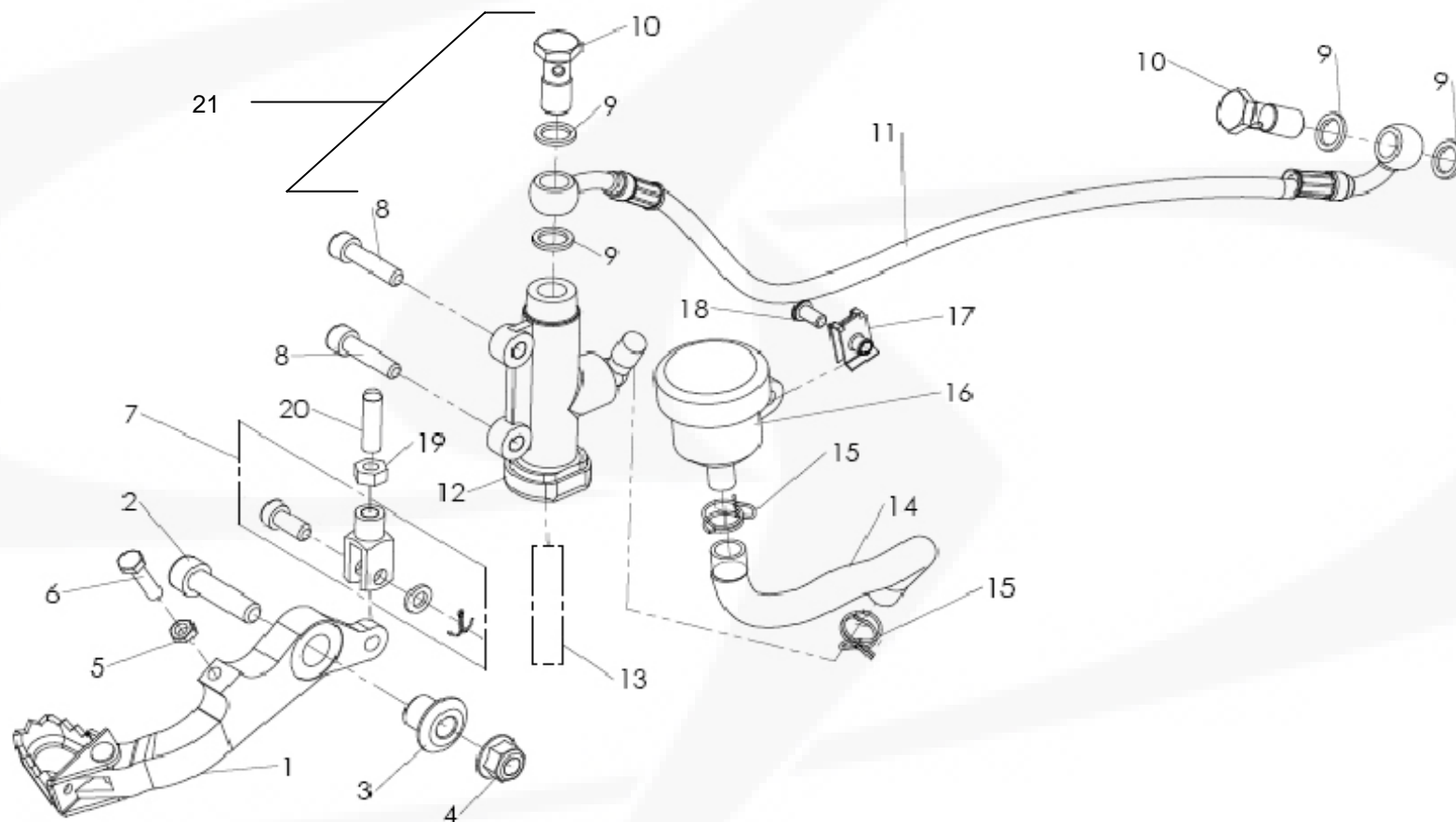



FIG. 34 – MAÎTRE CYLINDRE FREIN ARRIÈRE / REAR BRAKE MASTER CYLINDER / BOMBA FRENO TRASERO

N°	REF.	FRANÇAIS	ENGLISH	ESPAÑOL	QTY
1	S10B-40801-00-00	PÉDALE DE FREIN ARRIÈRE	PEDAL, REAR BRAKE	PEDAL FRENO TRASERO	1
2	9CHC0-08035-00	VIS PÉDALE DE FREIN	SCREW, REAR BRAKE PEDAL	TORNILLO PEDAL DE FRENO	1
3	9E014-08020-13	ENTRETOISE PÉDALE DE FREIN	SPACER, REAR BRAKE PEDAL	CASQUILLO PEDAL DE FRENO	1
4	90185-08169-00	ECROU PÉDALE DE FREIN	NUT, REAR BRAKE PEDAL	TUERCA PEDAL DE FRENO	1
5	95617-05100-00	ECROU RÉGLAGE PÉDALE DE FREIN	NUT, REAR BRAKE PEDAL ADJUSTER	TUERCA AJUSTE PEDAL DE FRENO	1
6	90TH0-05016-00	VIS RÉGLAGE PÉDALE DE FREIN	SCREW, REAR BRAKE PEDAL ADJUSTER	TORNILLO AJUSTE PEDAL DE FRENO	1
7	S3A-40802-00-00	CHAPE PÉDALE DE FREIN	CLEVIS, REAR BRAKE	RÓTULA PEDAL DE FRENO	1
8	91317-06025-00	VIS MAÎTRE CYLINDRE	SCREW, MASTER CYLINDER	TORNILLO BOMBA	2
9*	9ROJT-10014-00	RONDELLE RACCORD	WASHER, UNION SCREW	ARANDELA CONEXIÓN	4
10*	S1A-40104-00-00	VIS RACCORD	SCREW, UNION	TORNILLO CONEXIÓN	2
11*	S10B-40401-00-00	DURIT FREIN ARRIÈRE	HOSE, REAR BRAKE	LATIGUILLO FRENO TRASERO	1
12*	S1A-40601-00-00	MAÎTRE CYLINDRE FREIN ARRIÈRE	MASTER CYLINDER, REAR BRAKE	BOMBA FRENO TRASERO	1
13	S1A-40602-00-00	KIT RÉPARATION MAÎTRE CYLINDRE FREIN ARRIÈRE	REPAIR KIT, REAR MASTER CYLINDER ASSY	KIT REPARACIÓN BOMBA FRENO TRASERO	1
14*	9DU05-08130-00	DURIT LIQUIDE DE FREIN	HOSE, REAR BRAKE LIQUID CONTAINER	LATIGUILLO LIQUIDO FRENO	1
15*	9CLDU-08000-00	CLIP DURIT	SPRING CLIP	CLIP LATIGUILLO	2
16*	S1A-40204-00-00	BOCAL LIQUIDE DE FREIN	LIQUID CONTAINER, REAR BRAKE	DEPÓSITO LIQUIDO FRENO	1
17	9CE05-12715-00	CLIP ÉCROU	NUT CLIP	GRAPA TUERCA	1
18	92014-05012-00	VIS BOCAL LIQUIDE FREIN	SCREW, LIQUID CONTAINER	TORNILLO DEPÓSITO LIQUIDO FRENO	1
19	9EC02-06000-00	ECROU CHAPE PÉDALE	NUT, BRAKE ROD	TUERCA RÓTULA PEDAL	1
20	9ORN0-06034-00	TIGE FREIN	ROD, REAR BRAKE	VARILLA FRENO TRASERO	1
21	S10B-40200-00-00	FREIN ARRIÈRE ASSEMBLÉ	REAR BRAKE ASSY	FRENO TRASERO COMPLETO	1

\* INCLUS DANS FREIN ARRIÈRE ASSEMBLÉ AVEC LES PIÈCES DE /  
INCLUDED IN REAR BRAKE ASSY WITH PARTS OF /  
INCLUIDO EN FRENO TRASERO COMPLETO CON PIEZAS DE

FIG. 31 FREIN ARRIÈRE / REAR BRAKE / FRENO TRASERO :

- S1A-40026-00-00
- S1A-40201-00-00
- S1A-40207-00-00
- S1A-40208-00-00
- S10B-40202-00-00



### 35 – BEQUILLE ET REPOSE-PIEDS / STAND AND FOOTREST / CABALLETE Y ESTRIBOS

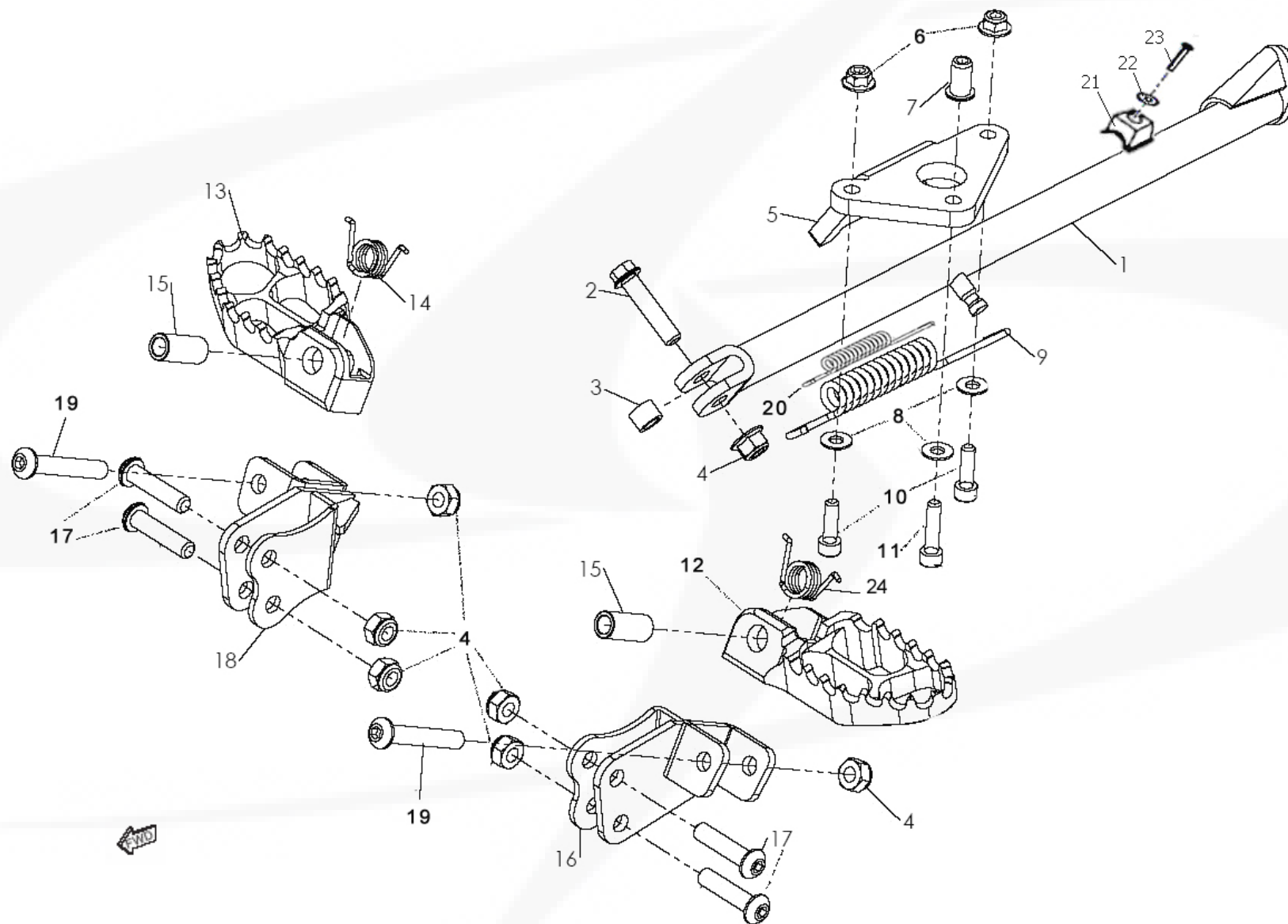



FIG. 35 - BÉQUILLE ET REPOSE-PIEDS / STAND AND FOOTREST / CABALLETE Y ESTRIBOS

N°	REF.	FRANÇAIS	ENGLISH	ESPAÑOL	QTY
1	S10B-20401-00-00	BÉQUILLE	SIDE STAND	CABALLETE	1
2	95027-08030-00	AXE BÉQUILLE	AXLE, SIDE STAND	EJE CABALLETE	1
3	9E008-08012-00	ENTRETOISE BÉQUILLE	SPACER, SIDE STAND	CASQUILLO CABALLETE	1
4	90185-08169-00	ECROU	NUT	TUERCA	7
5	S10B-20402-00-00	SUPPORT BÉQUILLE	BRACKET, SIDE STAND	SOPORTE CABALLETE	1
6	95704-06500-00	ECROU SUPPORT BÉQUILLE	NUT, SIDE STAND BRACKET	TUERCA SOPORTE CABALLETE	2
7	9EC10-06000-00	ECROU RIVET	NUT WITH RIVET	TUERCA REMACHE	1
8	9ROPL-06019-00	RONDILLE SUPPORT BÉQUILLE	WASHER, SIDE STAND BRACKET	ARANDELA SOPORTE CABALLETE	3
9	S1A-20403-00-00	RESSORT BÉQUILLE 1	SPRING 1, SIDE STAND	MUELLE CABALLETE 1	1
10	91317-06020-00	VIS SUPPORT BÉQUILLE	SCREW, SIDE STAND BRACKET	TORNILLO SOPORTE CABALLETE	2
11	91317-06025-00	VIS SUPPORT BÉQUILLE	SCREW, SIDE STAND BRACKET	TORNILLO SOPORTE CABALLETE	1
12	S10B-20201-10-00	REPOSE-PIED GAUCHE	FOOTREST, LEFT SIDE	ESTRIBO IZQUIERDO	1
13	S10B-20202-10-00	REPOSE-PIED DROIT	FOOTREST, RIGHT SIDE	ESTRIBO DERECHO	1
14	S1A-20203-00-00	RESSORT REPOSE-PIED DROIT	TORSION SPRING, FOOTREST RIGHT	MUELLE ESTRIBO DERECHO	1
15	1063	ENTRETOISE REPOSE-PIEDS	SPACER, FOOTREST	CASQUILLO ESTRIBOS	2
16	S10B-20205-00-PE	SUPPORT REPOSE-PIED GAUCHE	FOOTREST BRACKET, LEFT SIDE	SOPORTE ESTRIBO IZQUIERDO	1
17	9BHCO-08030-00	VIS SUPPORT REPOSE-PIEDS	SCREW, FOOTREST BRACKET	TORNILLO SOPORTE ESTRIBOS	4
18	S10B-20206-00-PE	SUPPORT REPOSE-PIED DROIT	FOOTREST BRACKET, RIGHT SIDE	SOPORTE ESTRIBO DERECHO	1
19	9BHCO-08045-00	VIS REPOSE-PIEDS	SCREW, FOOTREST	TORNILLO ESTRIBOS	2
20	S3A-20403-00-00	RESSORT BÉQUILLE 2	SPRING 2, SIDE STAND	MUELLE CABALLETE 2	1
21	S3A-20404-00-00	TAMPON BÉQUILLE	PAD, SIDE STAND	GOMA CABALLETE	1
22	9ROPL-03010-00	RONDILLE TAMPON	WASHER, PAD	ARANDELA GOMA	1
23	90008-37316-00	RIVET POP	POP RIVET	REMACHE POP	1
24	S1A-20204-00-00	RESSORT REPOSE-PIED GAUCHE	TORSION SPRING, FOOTREST LEFT	MUELLE ESTRIBO IZQUIERDO	1





35 bis – BEQUILLE ET REPOSE-PIEDS LONG-RIDE / STAND AND FOOTREST L-R / CABALLETE Y ESTRIBOS L-R

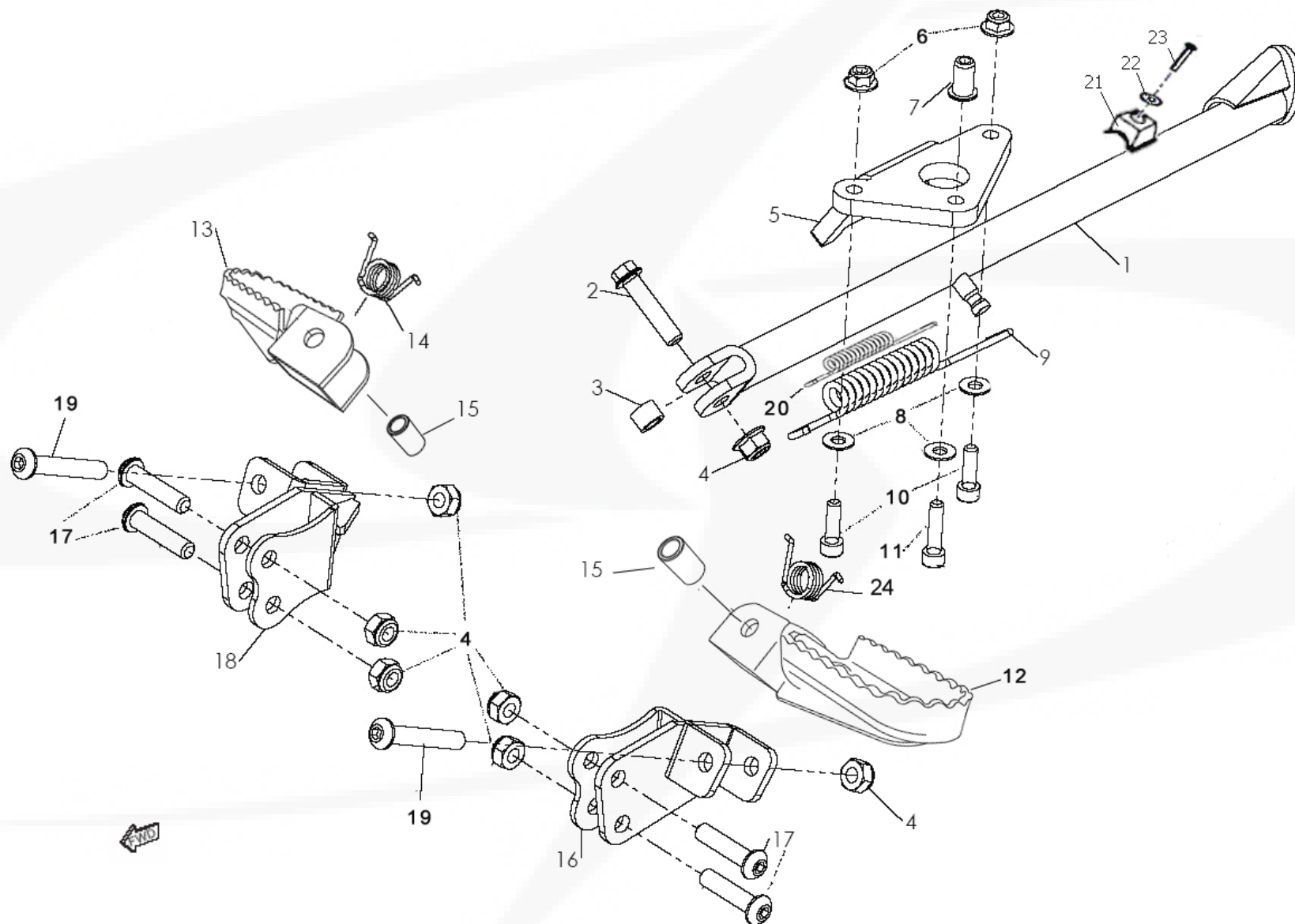



FIG. 35 BIS - BÉQUILLE ET REPOSE-PIEDS LONG-RIDE / STAND AND FOOTREST LONG-RIDE / CABALLETE Y ESTRIBOS LONG-RIDE

N°	REF.	Français	English	Español	QTY
1	S10B-20401-00-00	BÉQUILLE	SIDE STAND	CABALLETE	1
2	95027-08030-00	AXE BÉQUILLE	AXLE, SIDE STAND	EJE CABALLETE	1
3	9E008-08012-00	ENTRETOISE BÉQUILLE	SPACER, SIDE STAND	CASQUILLO CABALLETE	1
4	90185-08169-00	ECROU	NUT	TUERCA	7
5	S10B-20402-00-00	SUPPORT BÉQUILLE	BRACKET, SIDE STAND	SOPORTE CABALLETE	1
6	95704-06500-00	ECROU SUPPORT BÉQUILLE	NUT, SIDE STAND BRACKET	TUERCA SOPORTE CABALLETE	2
7	9EC10-06000-00	ECROU RIVET	NUT WITH RIVET	TUERCA REMACHE	1
8	9ROPL-06019-00	RONDILLE SUPPORT BÉQUILLE	WASHER, SIDE STAND BRACKET	ARANDELA SOPORTE CABALLETE	3
9	S1A-20403-00-00	RESSORT BÉQUILLE 1	SPRING 1, SIDE STAND	MUELLE CABALLETE 1	1
10	91317-06020-00	VIS SUPPORT BÉQUILLE	SCREW, SIDE STAND BRACKET	TORNILLO SOPORTE CABALLETE	2
11	91317-06025-00	VIS SUPPORT BÉQUILLE	SCREW, SIDE STAND BRACKET	TORNILLO SOPORTE CABALLETE	1
12	S1A-20201-00-00	REPOSE-PIED GAUCHE	FOOTREST, LEFT SIDE	ESTRIBO IZQUIERDO	1
13	S1A-20202-00-00	REPOSE-PIED DROIT	FOOTREST, RIGHT SIDE	ESTRIBO DERECHO	1
14	S1A-20203-00-00	RESSORT REPOSE-PIED DROIT	TORSION SPRING, FOOTREST RIGHT	MUELLE ESTRIBO DERECHO	1
15	9E018-08012-00	ENTRETOISE REPOSE-PIEDS	SPACER, FOOTREST	CASQUILLO ESTRIBOS	2
16	S10B-20205-00-PE	SUPPORT REPOSE-PIED GAUCHE	FOOTREST BRACKET, LEFT SIDE	SOPORTE ESTRIBO IZQUIERDO	1
17	9BHC0-08030-00	VIS SUPPORT REPOSE-PIEDS	SCREW, FOOTREST BRACKET	TORNILLO SOPORTE ESTRIBOS	4
18	S10B-20206-00-PE	SUPPORT REPOSE-PIED DROIT	FOOTREST BRACKET, RIGHT SIDE	SOPORTE ESTRIBO DERECHO	1
19	9BHC0-08045-00	VIS REPOSE-PIEDS	SCREW, FOOTREST	TORNILLO ESTRIBOS	2
20	S3A-20403-00-00	RESSORT BÉQUILLE 2	SPRING 2, SIDE STAND	MUELLE CABALLETE 2	1
21	S3A-20404-00-00	TAMPON BÉQUILLE	PAD, SIDE STAND	GOMA CABALLETE	1
22	9ROPL-03010-00	RONDILLE TAMPON	WASHER, PAD	ARANDELA GOMA	1
23	90008-37316-00	RIVET POP	POP RIVET	REMACHE POP	1
24	S1A-20204-00-00	RESSORT REPOSE-PIED GAUCHE	TORSION SPRING, FOOTREST LEFT	MUELLE ESTRIBO IZQUIERDO	1



### 36 – FEU ARRIERE / REAR LIGHT / FARO TRASERO

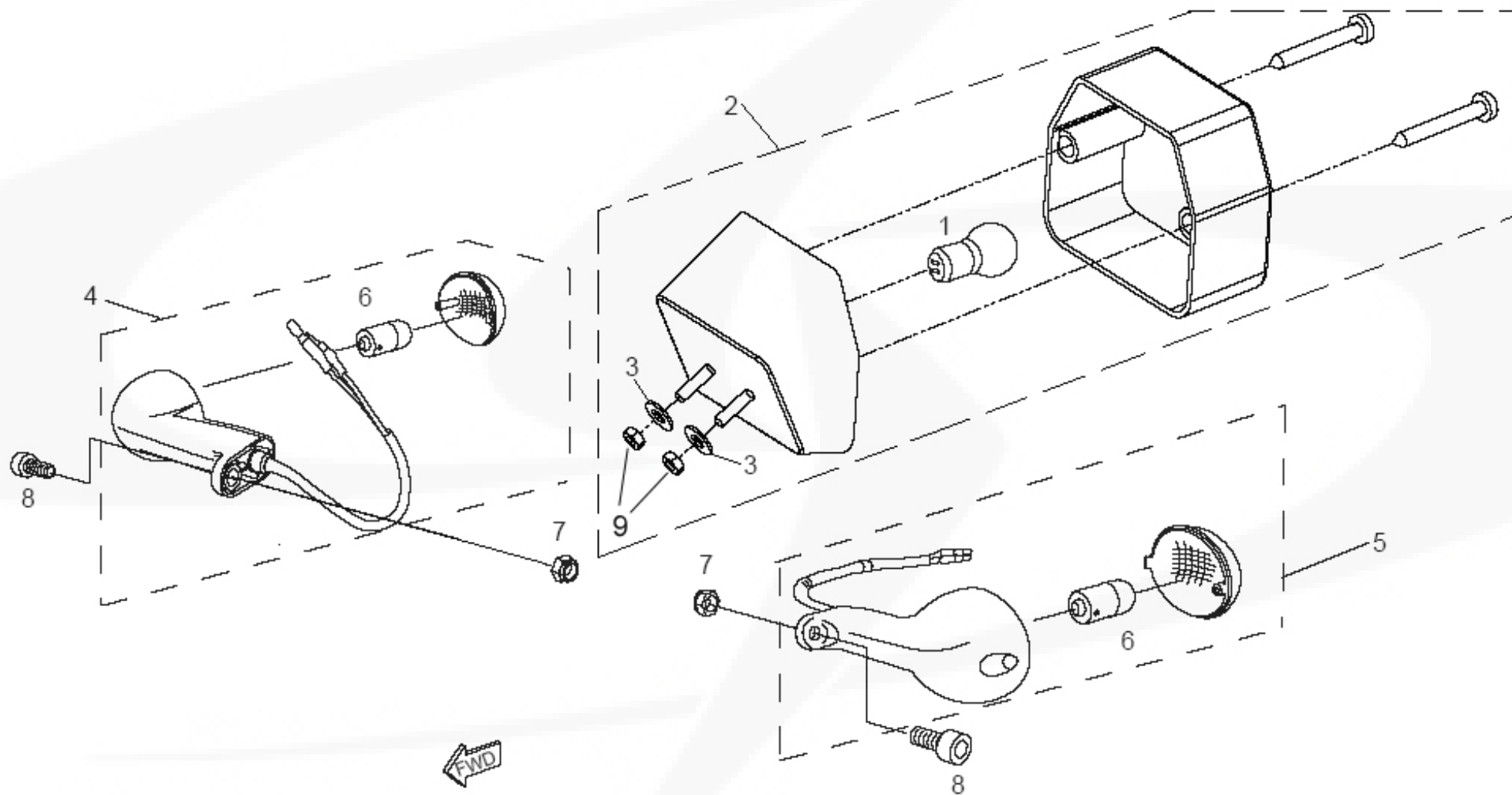



FIG. 36 – FEU ARRIÈRE / REAR LIGHT / FARO TRASERO

N°	REF.	FRANÇAIS	ENGLISH	ESPAÑOL	QTY
1	9AM12-05021-BA	AMPOULE FEU ARRIÈRE	BULB, REAR LIGHT	BOMBILLA FARO TRASERO	1
2	S10B-30401-00-00	FEU ARRIÈRE ASSEMBLÉ	REAR LIGHT ASSY	FARO TRASERO COMPLETO	1
3	9ROPL-05015-00	RONDILLE	WASHER	ARANDELA	2
4	S1A-30202-00-00	CLIGNOTANT ARRIÈRE DROIT	DIRECTION LIGHT, REAR RIGHT SIDE	INTERMITENTE IZQUIERDO TRASERO	1
5	S1A-30201-00-00	CLIGNOTANT ARRIÈRE GAUCHE	DIRECTION LIGHT, REAR LEFT SIDE	INTERMITENTE DERECHO TRASERO	1
6	9AM12-10000-BA	AMPOULE CLIGNOTANTS	BULB, DIRECTION LIGHTS REAR	BOMBILLA INTERMITENTES	2
7	95617-05100-00	ECROU CLIGNOTANTS	NUT, DIRECTION LIGHTS	TUERCA INTERMITENTES	2
8	91317-05012-00	VIS CLIGNOTANTS	SCREW, DIRECTION LIGHTS	TORNILLO INTERMITENTES	2
9	4385	ECROU NYLSTOP	NUT	TUERCA	2



37 – PLAQUE PHARE / HEAD LIGHT / FARO DELANTERO

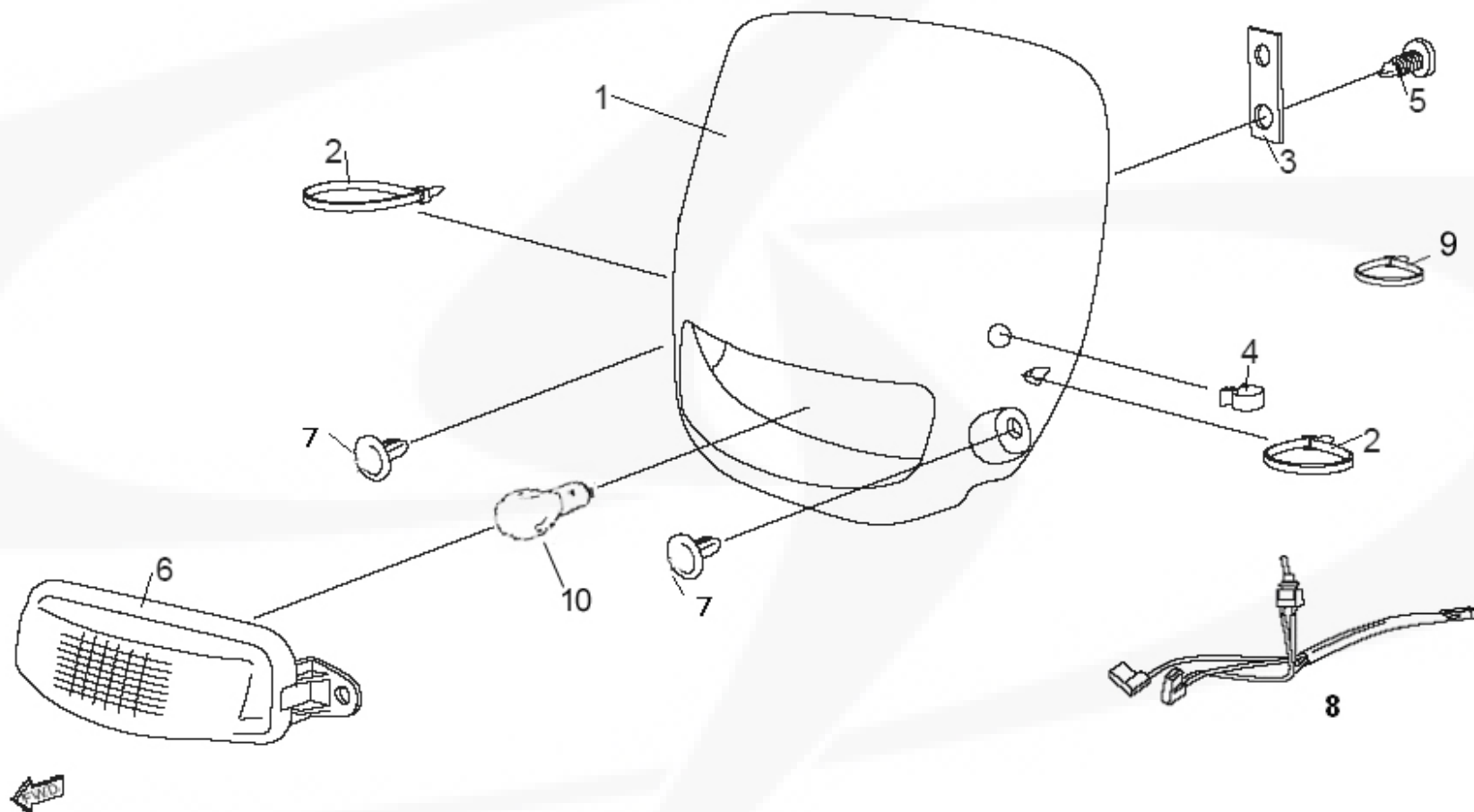



FIG. 37 – PLAQUE PHARE / HEAD LIGHT / FARO DELANTERO

N°	REF.	FRANÇAIS	ENGLISH	ESPAÑOL	QTY
1	S10B-80501-00-00	PLAQUE PHARE	BODY ASSY, HEAD LIGHT	FARO DELANTERO	1
2	9CORY-48280-N0	COLLIER RISLAN 4.8*280	LOCKING COLLAR 4.8*280	ABRAZADERA 4.8*280	2
3	90004-02500-00	SUPPORT INTERRUPTEUR	BRACKET, SWITCH	SOPORTE INTERRUPTOR	1
4	90036-00202-00	GUIDE DURIT DE FREIN	SPRING CLIP	GANCHO LATIGUILLO FRENO	1
5	9VSAU-48016-00	VIS SUPPORT INTERRUPTEUR	SCREW, SWITCH BRACKET	TORNILLO SOPORTE INTERRUPTOR	1
6	S2A-30301-00-00	OPTIQUE	HEAD LIGHT UNIT ASSY	ÓPTICA	1
7	90036-59901-00	RIVET SNIP SNAP	FIX CLAMP SNIP SNAP	REMACHE SNIP SNAP	4
8	S2A-30903-00-00	FAISCEAU ÉLECTRIQUE FEU AVANT	WIRING ELECTRICAL	INSTALACIÓN ELÉCTRICA FARO DELANTERO	1
9	9CORY-25100-N0	COLLIER RISLAN 2.5*100	LOCKING COLLAR 2.5*100	ABRAZADERA 2.5*100	1
10	9AM12-05000-CV	AMPOULE 12V 5W	BULB 12V 5W	BOMBILLA 12V 5W	1



### 38 – PLAQUE PHARE EURO / EURO HEAD LIGHT / FARO DELANTERO EURO

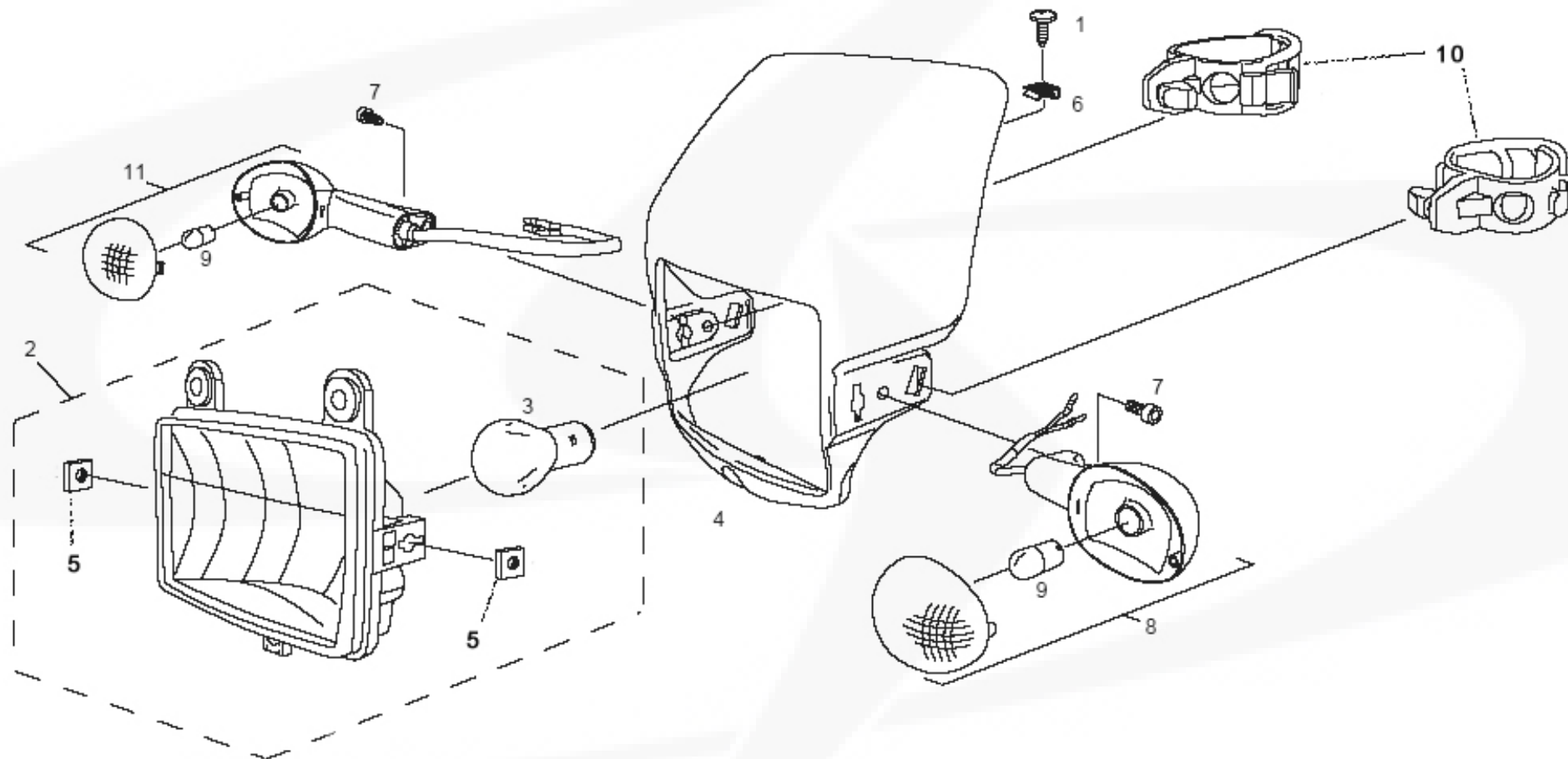



FIG. 38 – PLAQUE PHARE / HEAD LIGHT / FARO DELANTERO

N°	REF.	FRANÇAIS	ENGLISH	ESPAÑOL	QTY
1	9VSPA-42013-00	VIS RÉGLAGE POSITION PHARE	SCREW, ADJUSTING HEAD LIGHT POSITION	TORNILLO AJUSTE POSICIÓN FARO	1
2	S3A-30301-00-00	OPTIQUE AVANT EURO	HEAD LIGHT UNIT ASSY, EURO	ÓPTICA DELANTERA EURO	1
3	9AM12-35035-BA	AMPOULE OPTIQUE AVANT EURO	BULB, EURO HEAD LIGHT	BOMBILLA ÓPTICA DELANTERA EURO	1
4	S3A-80501-00-NP	PLAQUE PHARE AVANT EURO	BODY ASSY, HEAD LIGHT EURO	FARO DELANTERO EURO	1
5	9ECD4-06000-AL	ECROU CARRÉ FIXATION OPTIQUE	SQUARE NUT, HEAD LIGHT UNIT	TUERCA CUADRADA FIJACIÓN ÓPTICA	2
6	9CE42-10412-00	CLIP ÉCROU	SPRING CLIP	GRAPA TUERCA	1
7	91317-06020-00	VIS CLIGNOTANTS	SCREW DIRECTION LIGHTS	TORNILLO INTERMITENTES	2
8	S1A-30202-00-00	CLIGNOTANT AVANT GAUCHE	DIRECTION LIGHT, FRONT LEFT SIDE	INTERMITENTE DELANTERO IZQUIERDO	1
9	9AM12-10000-BA	AMPOULE CLIGNOTANT AVANT	BULB, DIRECTION LIGHT FRONT	BOMBILLA INTERMITENTE DELANTERO	2
10	S1A-80502-00-00	ÉLASTIQUE PLAQUE PHARE	RUBBER, HEAD LIGHT ATTACHING	ELÁSTICO FARO DELANTERO	2
11	S1A-30201-00-00	CLIGNOTANT AVANT DROIT	DIRECTION LIGHT, FRONT RIGHT SIDE	INTERMITENTE DELANTERO DERECHO	1





### 39 – FAISCEAU ELECTRIQUE / ELECTRICAL WIRINGS / INSTALACIÓN ELÉCTRICA

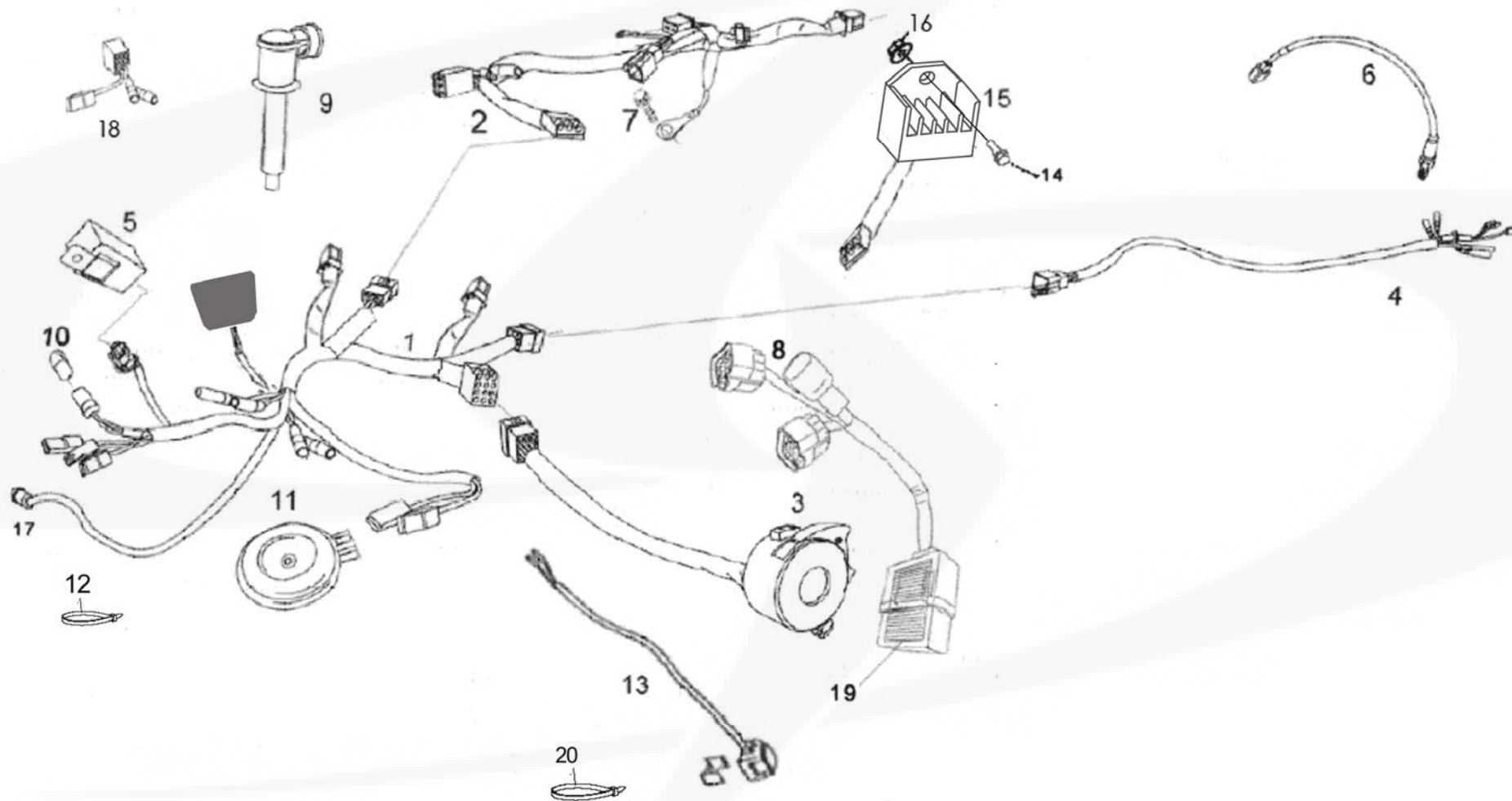



FIG. 39 – FAISCEAU ÉLECTRIQUE / ELECTRICAL WIRINGS / INSTALACIÓN ELÉCTRICA

N°	REF.	FRANÇAIS	ENGLISH	ESPAÑOL	QTY
1	S10B-30908-00-00	FAISCEAU ÉLECTRIQUE AVANT	WIRING ELECTRICAL, FORWARD	INSTALACIÓN ELÉCTRICA ANTERIOR	1
2	S10B-30901-00-00	FAISCEAU ÉLECTRIQUE PRINCIPAL	WIRING ELECTRICAL, CENTER	INSTALACIÓN ELÉCTRICA GENERAL	1
3	S10B-30601-00-00	COMMODE FEUX	CONTROL UNIT AND WIRING	CONMUTADOR	1
4	S10B-30902-00-00	FAISCEAU ÉLECTRIQUE ARRIÈRE	WIRING ELECTRICAL, AFT	INSTALACIÓN ELÉCTRICA TRASERA	1
5	S1A-30203-00-00	CENTRALE CLIGNOTANTE	GENERATOR UNIT, DIRECTION LIGHT	UNIDAD INTERMITENTE GENERAL	1
6	S10B-30905-00-00	FAISCEAU ÉLECTRIQUE FREIN ARRIÈRE	WIRING ELECTRICAL, REAR BRAKE	INSTALACIÓN ELÉCTRICA FRENA TRASERO	1
7	95827-06012-00	VIS MASSE	SCREW, GROUND	TORNILLO MASA	1
8	5UM-85540-10-00	CDI	CDI, IGNITION UNIT	CDI	1
9	5UL-82310-00-00	BOBINE ANTIPARASITE	IGNITION COIL	BOBINA ENCENDIDO	1
10	9AM12-05000-CV	AMPOULE 12V 5W	BULB, 12V 5W	LÁMPARA 12V 5W	1
11	S3A-30701-00-00	KLAXON	WARNING HORN	CLAXON	1
12	9CORY-25100-NO	COLLIER RISLAN 2.5*100	LOCKING COLLAR 2.5*100	ABRAZADERA 2.5*100	1
13	23X-83976-00-00	COUPE CIRCUIT	ENGINE STOP SWITCH	INTERRUPTOR CDI	1
14	95027-06020-00	VIS FIXATION RÉGULATEUR	SCREW, REGULATOR FIXING	TORNILLO FIJACIÓN CDI	1
15	4CK-81960-01-00	RÉGULATEUR PRINCIPAL	REGULATOR, MAIN	REGULADOR PRINCIPAL	1
16	95704-06500-00	ÉCROU FIXATION RÉGULATEUR	NUT, REGULATOR FIXING	TUERCA FIJACIÓN REGULADOR	1
17	S10B-30909-00-00	CAPTEUR FREIN AVANT	SENSOR, FRONT BRAKE	SENSOR FRENO DELANTERO	1
18	S10B-30201-00-00	RÉGULATEUR MOTEUR VENTILATEUR	REGULATOR, FAN MOTOR	REGULADOR MOTOR VENTILADOR	1
19	S10B-30108-00-00	ADHÉSIF FIXATION CDI (6CM)	ADHESIVE ATTACHING, CDI FIXING	ADHESIVO FIJACIÓN CDI (6CM)	2
20	9CORY-36140-NO	COLLIER RISLAN 3.6*140	LOCKING COLLAR 3.6*140	ABRAZADERA 3.6*140	2



## 40 – COMPTEUR ELECTRONIQUE / SPEEDOMETER / MULTIFUNCIÓN

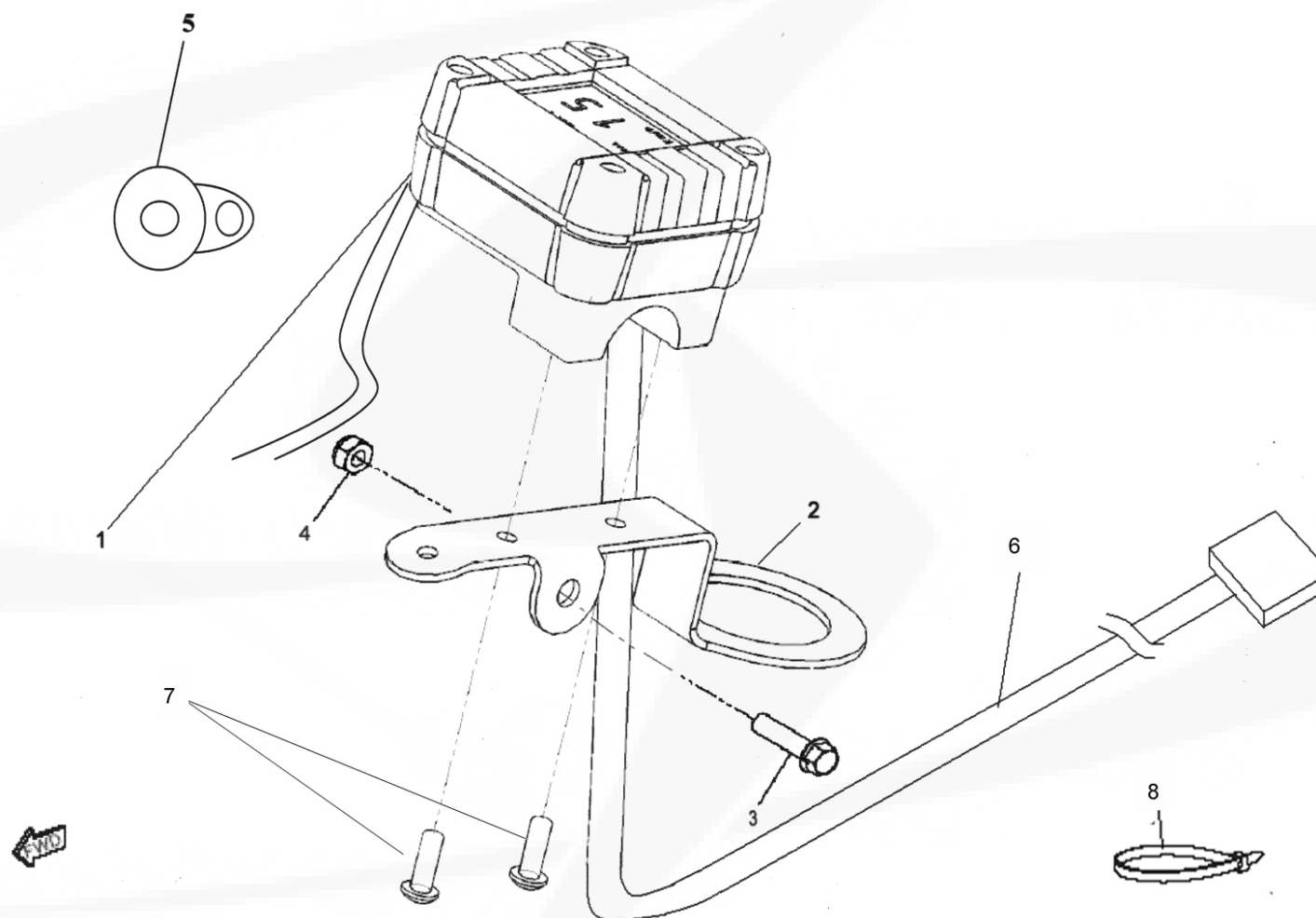



FIG. 40 - COMPTEUR ÉLECTRONIQUE / SPEEDOMETER / MULTIFUNCIÓN

N°	REF.	FRANÇAIS	ENGLISH	ESPAÑOL	QTY
1	S10B-60601-00-00	COMPTEUR ÉLECTRONIQUE	SPEEDOMETER	MULTIFUNCIÓN	1
2	S10B-60604-00-00	SUPPORT COMPTEUR	BRACKET, SPEEDOMETER	SOPORTE MULTIFUNCIÓN	1
3	3SP-23356-L0-00	VIS KLAXON	SCREW, HORN	TORNILLO KLAXON	1
4	95704-06500-00	ECROU KLAXON	NUT, HORN	TUERCA KLAXON	1
5	S10B-60607-00-00	AIMANT COMPTEUR	MAGNET, SPEEDOMETER	IMÁN MULTIFUNCIÓN	1
6	S10B-60602-00-00	CÂBLE COMPTEUR	CABLE, SPEEDOMETER	CABLE MULTIFUNCIÓN	1
7	9CHC0-05012-00	VIS COMPTEUR	SCREW, SPEEDOMETER	TORNILLO MULTIFUNCIÓN	2
8	9CORY-48280-NO	COLLIER RISLAN 4.8*280	LOCKING COLLAR 4.8*280	ABRAZADERA 4.8*280	1



41 – PLASTIQUES / PLASTICS / PLÁSTICOS

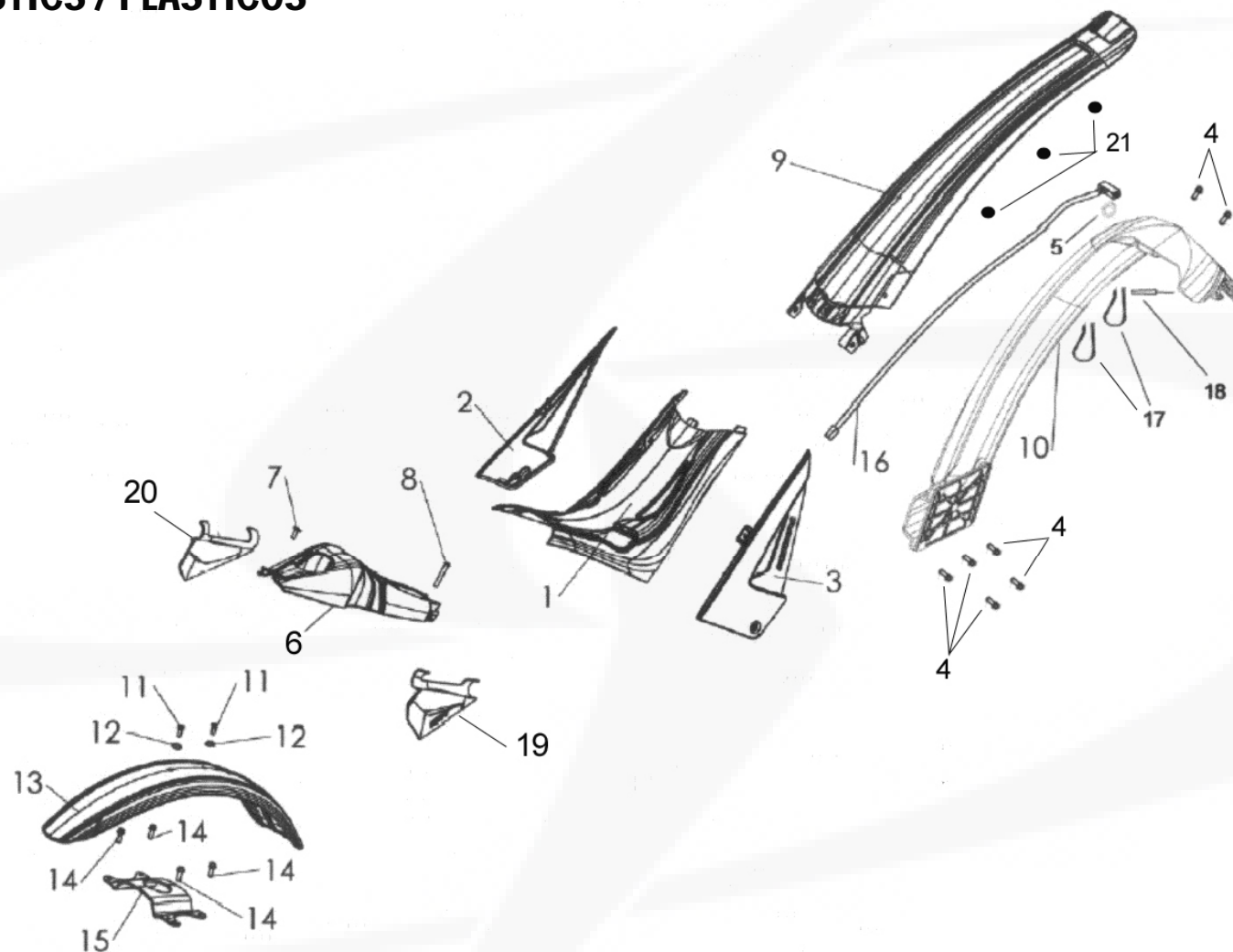



FIG. 41 - PLASTIQUES / PLASTICS / PLÁSTICOS

N°	REF.	FRANÇAIS	ENGLISH	ESPAÑOL	QTY
1	S10B-80401-00-00	CACHE BOÎTE À AIR	COVER, AIR FILTER CASE	BASE ASIENTO	1
2	S10B-80808-00-00	PROTECTION LATÉRALE DROITE	PROTECTIVE PLATE, RIGHT SIDE	TAPA LATERAL DERECHA	1
3	S10B-80807-00-00	PROTECTION LATÉRALE GAUCHE	PROTECTIVE PLATE, LEFT SIDE	TAPA LATERAL IZQUIERDA	1
4	9BHCE-06012-ZI	VIS SUPPORT PLAQUE IMMATRICULATION	SCREW, SUPPORT LICENSE PLATE	TORNILLO PORTA MATRÍCULAS	7
5	9ROEV-02009-00	CLIP TÔLE FEU ARRIÈRE	WASHER, LED LAMP	CLIP LÁMPARA LEDS	1
6	S10B-80207-00-00	CACHE RÉSERVOIR	COVER, FUEL TANK AND SIDES	TAPA DEPÓSITO	1
7	9BHCE-06016-00	VIS CACHE RÉSERVOIR AVANT	SCREW, FUEL TANK COVER FRONT	TORNILLO TAPA DEPÓSITO DELANTERA	1
8	9BHCE-06040-00	VIS CACHE RÉSERVOIR ARRIÈRE	SCREW, FUEL TANK COVER REAR	TORNILLO TAPA DEPÓSITO TRASERA	1
9	S10B-80301-00-00	GARDE-BOUE ARRIÈRE	REAR FENDER	GUARDABARROS TRASERO	1
10	S10B-80302-00-00	SUPPORT PLAQUE D'IMMATRICULATION	SUPPORT LICENSE PLATE	PORTA MATRÍCULAS	1
11	9FHCO-05012-00	VIS GARDE-BOUE AVANT	SCREW, FRONT FENDER	TORNILLO GUARDABARROS DELANTERO	2
12	9ROFR-05015-00	RONDILLE GARDE-BOUE AVANT	WASHER, FRONT FENDER	ARANDELA GUARDABARROS DELANTERO	2
13	S10C-80101-00-00	GARDE-BOUE AVANT	FRONT FENDER	GUARDABARROS DELANTERO	1
14	95027-06012-00	VIS SUPPORT GARDE-BOUE AVANT	SCREW, FRONT FENDER BRACKET	TORNILLO SOPORTE GUARDABARROS DELANTERO	4
15	S1A-80102-00-00	SUPPORT GARDE-BOUE AVANT	BRACKET, FRONT FENDER	PUENTE HORQUILLA DELANTERA	1
16	S10B-30402-00-00	FEU ARRIÈRE À DIODES	ELECTRONIC LED LAMP	LÁMPARA LEDS TRASERA	1
17	90461-11099-00	GUIDE CÂBLE	CLAMP	BRIDA	2
18	9008-48100-00	RIVET	FIX CLAMP	REMACHE	1
19	S10B-80402-00-00	QUÏE RÉSERVOIR GAUCHE	SIDE PANEL, TANK LEFT	PLACA DEPÓSITO IZQUIERDA	1
20	S10B-80406-00-00	QUÏE RÉSERVOIR DROITE	SIDE PANEL, TANK RIGHT	PLACA DEPÓSITO DERECHA	1
21	S10D-80815-00-00	PASSE FIL DOUBLE	WIRE-PASS	PASA CABLE	3



41 bis – PLASTIQUES LONG-RIDE / LONG-RIDE PLASTICS / PLÁSTICOS LONG-RIDE

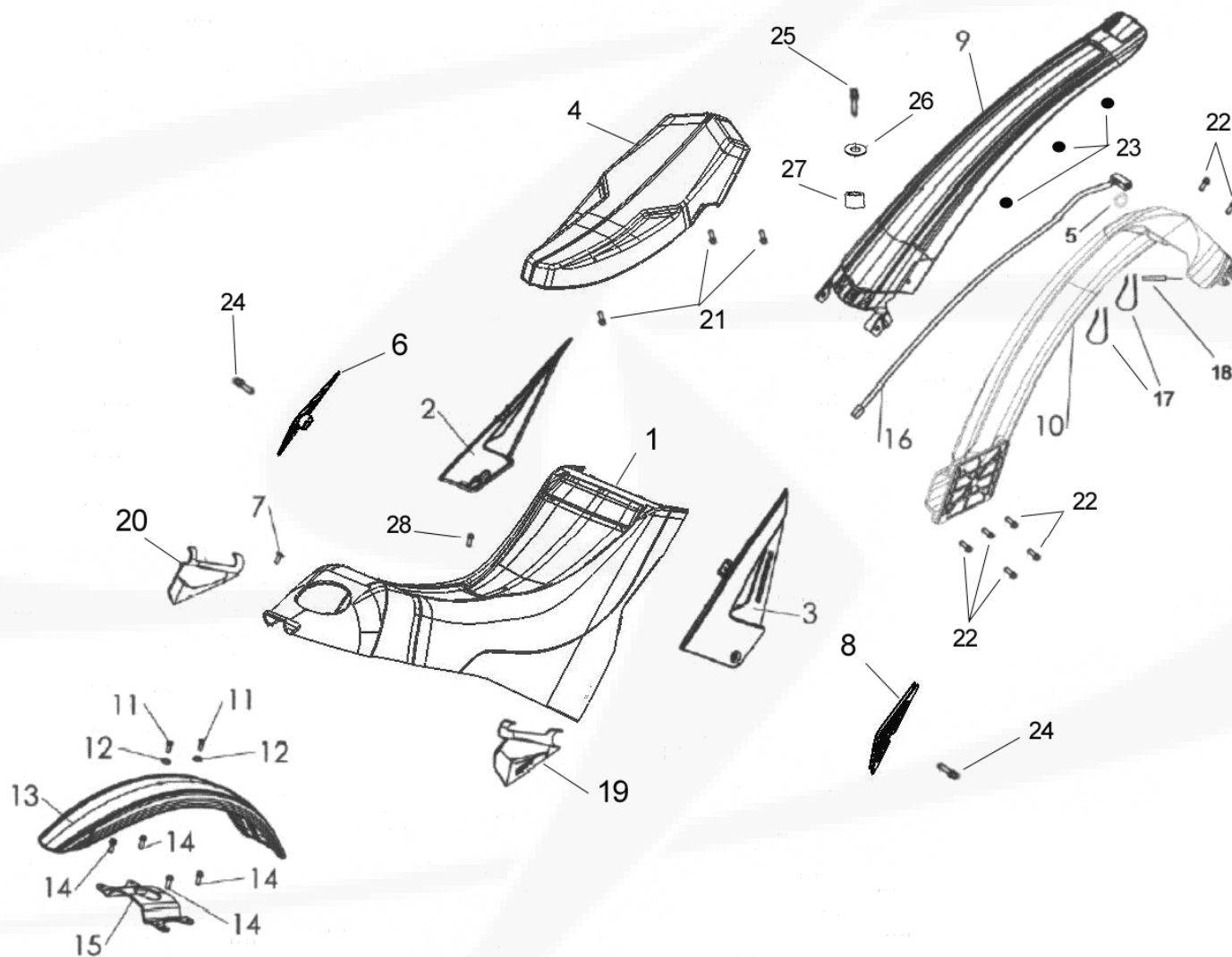



FIG. 41 BIS - PLASTIQUES LONG-RIDE / PLASTICS LONG-RIDE / PLÁSTICOS LONG-RIDE

N°	REF.	FRANÇAIS	ENGLISH	ESPAÑOL	QTY
1	S13D-80207-00-00	CAPOT RÉSERVOIR	COVER, FUEL TANK AND SIDES	TAPA DEPÓSITO	1
2	S10B-80808-00-00	PROTECTION LATÉRALE DROITE	PROTECTIVE PLATE, RIGHT SIDE	TAPA LATERAL DERECHA	1
3	S10B-80807-00-00	PROTECTION LATÉRALE GAUCHE	PROTECTIVE PLATE, LEFT SIDE	TAPA LATERAL IZQUIERDA	1
4	S13D-60101-00-00	SELLE	SEAT	ASIENTO	1
5	9ROEV-02009-00	CLIP TÔLE FEU ARRIÈRE	WASHER, LED LAMP	CLIP LÁMPARA LEDS	1
6	S13D-80405-00-00	GRILLE LATÉRALE DROITE	GRID, RIGHT SIDE	TAPETA LATERAL DERECHA	1
7	9BHCE-06016-00	VIS CACHE RÉSERVOIR AVANT	SCREW, FUEL TANK COVER FRONT	TORNILLO TAPA DEPÓSITO DELANTERA	1
8	S13D-80404-00-00	GRILLE LATÉRALE GAUCHE	GRID, LEFT SIDE	TAPETA LATERAL IZQUIERDA	1
9	S10B-80301-00-00	GARDE-BOUE ARRIÈRE	REAR FENDER	GUARDABARROS TRASERO	1
10	S10B-80302-00-00	SUPPORT PLAQUE D'IMMATRICULATION	SUPPORT LICENSE PLATE	PORTA MATRÍCULAS	1
11	9FHCO-05012-00	VIS GARDE-BOUE AVANT	SCREW, FRONT FENDER	TORNILLO GUARDABARROS DELANTERO	2
12	9ROFR-05015-00	RONDELLE GARDE-BOUE AVANT	WASHER, FRONT FENDER	ARANDELA GUARDABARROS DELANTERO	2
13	S10C-80101-00	GARDE-BOUE AVANT	FRONT FENDER	GUARDABARROS DELANTERO	1
14	95027-06012-00	VIS SUPPORT GARDE-BOUE AVANT	SCREW, FRONT FENDER BRACKET	TORNILLO SOPORTE GUARDABARROS DELANTERO	4
15	S1A-80102-00-00	SUPPORT GARDE-BOUE AVANT	BRACKET, FRONT FENDER	PUENTE HORQUILLA DELANTERA	1
16	S10B-30402-00-00	FEU ARRIÈRE À DIODES	ELECTRONIC LED LAMP	LÁMPARA LEDS TRASERA	1
17	90461-11099-00	GUIDE CÂBLE	CLAMP	BRIDA	1
18	9008-48100-00	RIVET	FIX CLAMP	REMACHE	1
19	S10B-80402-00-00	QUÏE RÉSERVOIR GAUCHE	SIDE PANEL, TANK LEFT	PLACA DEPÓSITO IZQUIERDA	1
20	S10B-80406-00-00	QUÏE RÉSERVOIR DROITE	SIDE PANEL, TANK RIGHT	PLACA DEPÓSITO DERECHA	1
21	9BHCE-05012-NO	VIS SELLE	SCREW, SEAT	TORNILLO ASIENTO	3
22	9BHCE-06012-ZI	VIS SUPPORT PLAQUE IMMATRICULATION	SCREW, SUPPORT LICENSE PLATE	TORNILLO PORTA MATRÍCULAS	7
23	S10D-80815-00-00	PASSE FIL DOUBLE	WIRE-PASS	PASA CABLE	3
24	9BHCO-06025-00	VIS GRILLES LATÉRALES	SCREW, SIDE GRID	TORNILLO, TAPETA LATERAL	2
25	9BHCE-06030-00	VIS CACHE RÉSERVOIR ARRIÈRE	SCREW, FUEL TANK COVER REAR	TORNILLO TAPA DEPÓSITO	1
26	9ROPL-06018-00	RONDELLE CACHE RÉSERVOIR	WASHER, FUEL TANK COVER	ARANDELA TAPA DEPÓSITO	1
27	9E012-07017-11	ENTRETOISE RÉSERVOIR ARRIÈRE	SPACER, FUEL TANK REAR	CASQUILLO DEPÓSITO	1
28	9BHCE-06012-NO	VIS CACHE RÉSERVOIR CENTRALE	SCREW, FUEL TANK COVER CENTER	TORNILLO TAPA DEPÓSITO CENTRAL	1





42 – ADHESIFS / STICKERS / ADHESIVOS

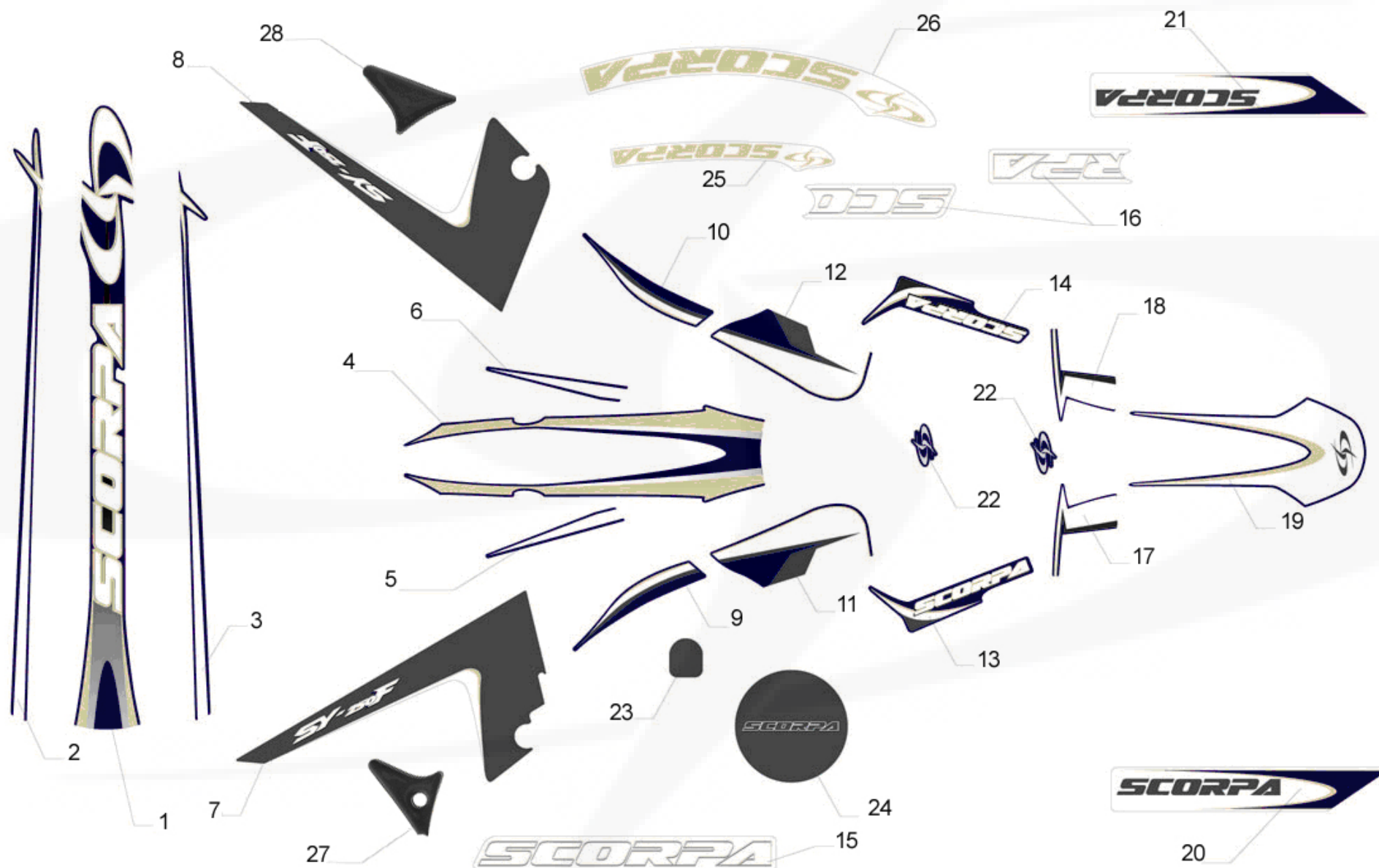



FIG. 42 – ADHÉSIFS / STICKERS / ADHESIVOS

N°	REF.	FRANÇAIS	ENGLISH	ESPAÑOL	QTY
1	S10D-90309-00-00	ADHÉSIF GARDE-BOUE ARRIÈRE	STICKER, REAR FENDER	ADHESIVO GUARDABARROS TRASERO	1
2	S10D-90308-00-00	ADHÉSIF GARDE-BOUE ARRIÈRE DROIT	STICKER, REAR FENDER RIGHT	ADHESIVO GUARDABARROS TRASERO DERECHO	1
3	S10D-90307-00-00	ADHÉSIF GARDE-BOUE ARRIÈRE GAUCHE	STICKER, REAR FENDER LEFT	ADHESIVO GUARDABARROS TRASERO IZQUIERDO	1
4	S10D-91105-00-00	ADHÉSIF CACHE BOÎTE À AIR	STICKER, AIR BOX COVER	ADHESIVO CAJA FILTRO	1
5	S10D-91104-00-00	ADHÉSIF CACHE BOÎTE À AIR ARRIÈRE DROIT	STICKER, AIR BOX COVER REAR RIGHT	ADHESIVO CAJA FILTRO TRASERO DERECHO	1
6	S10D-91103-00-00	ADHÉSIF CACHE BOÎTE À AIR ARRIÈRE GAUCHE	STICKER, AIR BOX COVER REAR LEFT	ADHESIVO CAJA FILTRO TRASERO IZQUIERDO	1
7	S10D-91302-00-00	ADHÉSIF PROTECTION LATÉRALE DROITE	STICKER, COVER RIGHT	ADHESIVO PROTECCIÓN LATERAL DERECHA	1
8	S10D-91301-00-00	ADHÉSIF PROTECTION LATÉRALE GAUCHE	STICKER, COVER LEFT	ADHESIVO PROTECCIÓN LATERAL IZQUIERDA	1
9	S10D-91102-00-00	ADHÉSIF CACHE BOÎTE À AIR AVANT DROIT	STICKER, AIR BOX COVER FRONT RIGHT	ADHESIVO CAJA FILTRO DELANTERO DERECHO	1
10	S10D-91101-00-00	ADHÉSIF CACHE BOÎTE À AIR AVANT GAUCHE	STICKER, AIR BOX COVER FRONT LEFT	ADHESIVO CAJA FILTRO DELANTERO IZQUIERDO	1
11	S10D-90203-00-00	ADHÉSIF RÉSERVOIR DROIT	STICKER, FUEL TANK RIGHT	ADHESIVO DEPÓSITO DERECHO	1
12	S10D-90201-00-00	ADHÉSIF RÉSERVOIR GAUCHE	STICKER, FUEL TANK LEFT	ADHESIVO DEPÓSITO IZQUIERDO	1
13	S10D-90204-00-00	ADHÉSIF LOGO RÉSERVOIR DROIT	STICKER, FUEL TANK LOGO RIGHT	ADHESIVO LOGO DEPÓSITO DERECHO	1
14	S10D-90202-00-00	ADHÉSIF LOGO RÉSERVOIR GAUCHE	STICKER, FUEL TANK LOGO LEFT	ADHESIVO LOGO DEPÓSITO IZQUIERDO	1
15	S10D-90402-00-00	ADHÉSIF BRAS OSCILLANT DROIT	STICKER, SWINGARM RIGHT	ADHESIVO BASCULANTE DERECHO	1
16	S10D-90401-00-00	ADHÉSIF BRAS OSCILLANT GAUCHE	STICKER, SWINGARM LEFT	ADHESIVO BASCULANTE IZQUIERDO	1
17	S10D-90503-00-00	ADHÉSIF PLAQUE-PHARE DROIT	STICKER, HEAD LIGHT RIGHT	ADHESIVO FARO DELANTERO DERECHO	1
18	S10D-90502-00-00	ADHÉSIF PLAQUE-PHARE GAUCHE	STICKER, HEAD LIGHT LEFT	ADHESIVO FARO DELANTERO IZQUIERDO	1
19	S10D-90101-00-00	ADHÉSIF GARDE-BOUE AVANT	STICKER, FRONT FENDER	ADHESIVO GUARDABARROS DELANTERO	1
20	S10D-90902-00-00	ADHÉSIF FOURCHE DROIT	STICKER, FORK RIGHT	ADHESIVO HORQUILLA DERECHO	1
21	S10D-90901-00-00	ADHÉSIF FOURCHE GAUCHE	STICKER, FORK LEFT	ADHESIVO HORQUILLA IZQUIERDO	1
22	S10B-90211-00-00	ADHÉSIF RÉSINE LOGO	STICKER, RESIN LOGO	ADHESIVO RESINA LOGO	2
23	S10D-90606-00-00	ADHÉSIF PROTECTION CADRE	STICKER, FRAME PROTECTION	ADHESIVO PROTECCIÓN BASTIDOR	1
24	S10D-91001-00-00	ADHÉSIF CARTER MOTEUR	STICKER, CRANKCASE	ADHESIVO CARTÉR MOTOR	1
25	S4D-91201-00-00	ADHÉSIF JANTE AVANT	STICKER, FRONT RIM	ADHESIVO LLANTA DELANTERA	2
26	S4D-91202-00-00	ADHÉSIF JANTE ARRIÈRE	STICKER, REAR RIM	ADHESIVO LLANTA TRASERA	2
27	S10B-90604-00-00	ADHÉSIF PLATINE DROITE	STICKER, FRAME RIGHT	ADHESIVO PLETINA DERECHA	1
28	S10B-90605-00-00	ADHÉSIF PLATINE GAUCHE	STICKER, FRAME LEFT	ADHESIVO PLETINA IZQUIERDA	1



42 bis – ADHESIFS LONG-RIDE / LONG-RIDE STICKERS / ADHESIVOS LONG-RIDE

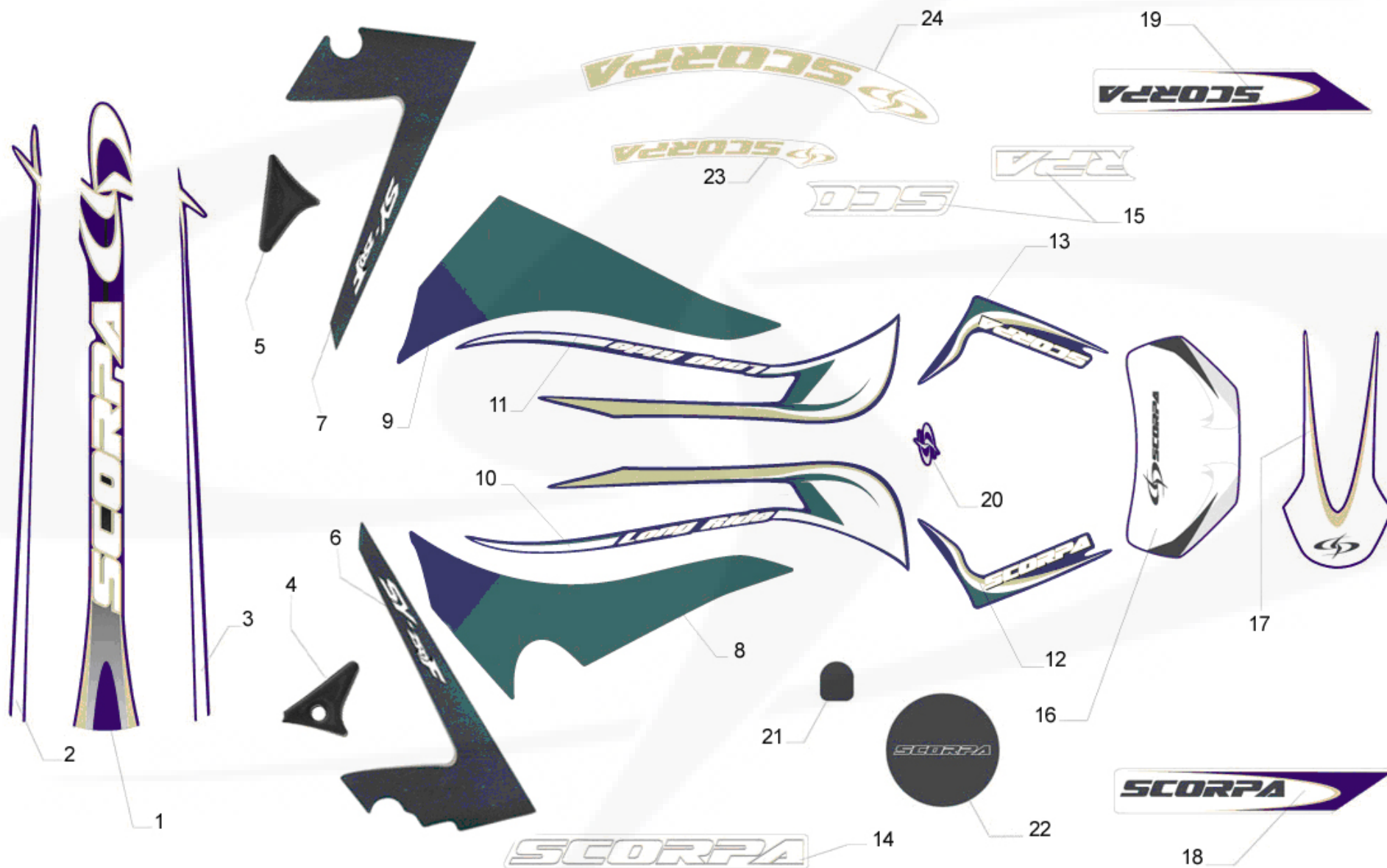



FIG. 42 BIS – ADHÉSIFS LONG-RIDE / LONG-RIDE STICKERS / ADHESIVOS LONG-RIDE

N°	REF.	FRANÇAIS	ENGLISH	ESPAÑOL	QTY
1	S10D-90309-00-00	ADHÉSIF GARDE-BOUE ARRIÈRE	STICKER, REAR FENDER	ADHESIVO GUARDABARROS TRASERO	1
2	S10D-90308-00-00	ADHÉSIF GARDE-BOUE ARRIÈRE DROIT	STICKER, REAR FENDER RIGHT	ADHESIVO GUARDABARROS TRASERO DERECHO	1
3	S10D-90307-00-00	ADHÉSIF GARDE-BOUE ARRIÈRE GAUCHE	STICKER, REAR FENDER LEFT	ADHESIVO GUARDABARROS TRASERO IZQUIERDO	1
4	S10B-90604-00-00	ADHÉSIF PLATINE DROITE	STICKER, FRAME RIGHT	ADHESIVO PLETINA DERECHA	1
5	S10B-90605-00-00	ADHÉSIF PLATINE GAUCHE	STICKER, FRAME LEFT	ADHESIVO PLETINA IZQUIERDA	1
6	S10D-91302-00-00	ADHÉSIF PROTECTION LATÉRALE DROITE	STICKER, COVER RIGHT	ADHESIVO PROTECCIÓN LATERAL DERECHA	1
7	S10D-91301-00-00	ADHÉSIF PROTECTION LATÉRALE GAUCHE	STICKER, COVER LEFT	ADHESIVO PROTECCIÓN LATERAL IZQUIERDA	1
8	S13D-91104-00-00	ADHÉSIF PROTECTION RÉSERVOIR DROIT	STICKER, FUEL TANK PROTECTION RIGHT	ADHESIVO PROTECTOR DEPÓSITO DERECHO	1
9	S13D-91103-00-00	ADHÉSIF PROTECTION RÉSERVOIR GAUCHE	STICKER, FUEL TANK PROTECTION LEFT	ADHESIVO PROTECTOR DEPÓSITO IZQUIERDO	1
10	S13D-90209-00-00	ADHÉSIF RÉSERVOIR DROIT	STICKER, FUEL TANK RIGHT	ADHESIVO DEPÓSITO DERECHO	1
11	S13D-90210-00-00	ADHÉSIF RÉSERVOIR GAUCHE	STICKER, FUEL TANK LEFT	ADHESIVO DEPÓSITO IZQUIERDO	1
12	S13D-90204-00-00	ADHÉSIF LOGO RÉSERVOIR DROIT	STICKER, FUEL TANK LOGO RIGHT	ADHESIVO LOGO DEPÓSITO DERECHO	1
13	S13D-90202-00-00	ADHÉSIF LOGO RÉSERVOIR GAUCHE	STICKER, FUEL TANK LOGO LEFT	ADHESIVO LOGO DEPÓSITO IZQUIERDO	1
14	S10D-90402-00-00	ADHÉSIF BRAS OSCILLANT DROIT	STICKER, SWINGARM RIGHT	ADHESIVO BASCULANTE DERECHO	1
15	S10D-90401-00-00	ADHÉSIF BRAS OSCILLANT GAUCHE	STICKER, SWINGARM LEFT	ADHESIVO BASCULANTE IZQUIERDO	1
16	S12C-90501-00-00	ADHÉSIF PLAQUE-PHARE	STICKER, HEAD LIGHT	ADHESIVO FARO DELANTERO	1
17	S10D-90101-00-00	ADHÉSIF GARDE-BOUE AVANT	STICKER, FRONT FENDER	ADHESIVO GUARDABARROS DELANTERO	1
18	S10D-90902-00-00	ADHÉSIF FOURCHE DROIT	STICKER, FORK RIGHT	ADHESIVO HORQUILLA DERECHO	1
19	S10D-90901-00-00	ADHÉSIF FOURCHE GAUCHE	STICKER, FORK LEFT	ADHESIVO HORQUILLA IZQUIERDO	1
20	S10B-90211-00-00	ADHÉSIF RÉSINE LOGO	STICKER, RESIN LOGO	ADHESIVO RESINA LOGO	1
21	S10D-90606-00-00	ADHÉSIF PROTECTION CADRE	STICKER, FRAME PROTECTION	ADHESIVO PROTECTOR BASTIDOR	1
22	S10D-91001-00-00	ADHÉSIF CARTER MOTEUR	STICKER, CRANKCASE	ADHESIVO CARTÉR MOTOR	1
23	S4D-91201-00-00	ADHÉSIF JANTE AVANT	STICKER, FRONT RIM	ADHESIVO LLANTA DELANTERA	2
24	S4D-91202-00-00	ADHÉSIF JANTE ARRIÈRE	STICKER, REAR RIM	ADHESIVO LLANTA TRASERA	2

**SY-250F & SY-250F**  
*Long Ride*



PÔLE MÉCANIQUE, VALLON DE FONTANÈS,  
30520 ST-MARTIN-DE-VALGALGUES FRANCE

TÉL. +33 (0) 466 543 610

FAX. +33 (0) 466 549 410

WWW.SCORPA.FR

SCORPA PIÈCES DÉTACHÉES / SPARE PARTS / PIEZAS RECAMBIO :

TÉL.+33 (0) 466 543 611 FAX. +33 (0) 466 305 446 E-MAIL : SERVICE@SCORPA.FR

SCORPA TECHNIQUE / TECHNICAL / TÉCNICA :

TÉL.+33 (0) 466 543 621 FAX. +33 (0) 466 305 446 E-MAIL : CONSULTANT3@SCORPA.FR

LES COMPOSANTS, EXPOSÉS ET RÉFÉRENCÉS ICI, SONT BASÉS SUR LES DONNÉES EXISTANTES À LA DATE D'IMPRESSIION DE CE MANUEL.  
SCORPA SA SE RÉSERVE LE DROIT D'EFFECTUER DES CHANGEMENTS ET/OU DES MODIFICATIONS SANS AVERTISSEMENT PRÉALABLE.

THE COMPONENTS - EXPOSED AND REFERENCED HERE - ARE BASED ON THE EXISTING DATA IN THE DATE OF IMPRESSION OF THIS  
MANUAL. SCORPA S.A. RESERVES THE RIGHT TO CHANGE AND/OR MODIFY WITHOUT PREVIOUS WARNING.

LOS COMPONENTES AQUI EXPUESTOS Y REFERENCIADOS SE BASAN EN LOS DATOS EXISTENTES EN LA FECHA DE IMPRESION DE ESTE  
MANUAL. SCORPA S.A. SE RESERVA EL DERECHO DE EFECTUAR CAMBIOS Y/O MODIFICACIONES SIN PREVIO AVISO.

LES PARTENAIRES DE

