

Electric Tricycle User Manual



Read Carefully Before Use
Keep for Future Reference

CONTENTS

Safety Information	1
Specifications	2
Product Diagram	3
Assembly	5
Rear Wheels.....	5
Rear and Main Frames.....	6
Front Wheel.....	7
Handlebars	8
Chain	9
Chain Guard	9
Saddle	10
Pedals.....	10
Rear Reflectors.....	11
Rear Fenders and Stays.....	12
Front Brake, Fender, Light, and Stay.....	13
Rear Brake	14
Basket.....	15
Wheel Caps.....	16
Operation	16
Charging	18
Maintenance	19
Contact Information	19

Safety Information

Warning!

- Install and adjust this tricycle **ONLY** in accordance with these instructions. Read them completely prior to assembly and use. Contact customer service if any point is unclear. Provide this manual to anyone who will use this tricycle and provide it with this tricycle (whether already assembled or not) if it is ever given or sold to a third party. Failure to do so may lead to serious property damage and severe personal injury.
- **ALWAYS** obey all applicable local and national laws and regulations while riding. Do not ride this tricycle in any area prohibited to electric bicycles or tricycles. Always wear your helmet and other required protective gear. Always maintain your reflectors and other required safety equipment.
- **ALWAYS** check whether the brakes function well using the brake levers **BEFORE** riding. Even when power is cut to the motor, the inertia of the tricycle will often require active braking power.
- **ALWAYS** ensure all fasteners and components are intact and securely tightened before and after every use.
- **DO NOT** ride this tricycle if any part is damaged or shows any sign of malfunction. Repair or replace worn and broken components before further use. Never replace any parts with nonidentical ones.
- Pay attention to the remaining power before setting out and during use. Recharge your battery as needed to ensure it never runs out of power at a moment where you are taken by surprise.
- **DO NOT** allow use by children or persons unfamiliar with this tricycle or these instructions. Do not ride this tricycle while you are tired or under the influence of drugs or medication.
- **DO NOT** wear loose footwear or clothing that may become caught in the wheels or any other moving parts.
- It is recommended that you not ride your tricycle fast until you are fully familiar with your new electric tricycle and its controls.
- **ALWAYS** be alert for people, animals, or any obstacles that may appear in front of you while riding your tricycle. Be aware that pedestrians and drivers may not expect the speed or responsiveness of your tricycle. Adjust your behavior accordingly. It is advisable to install warning devices to draw their attention, but always be ready to turn safely out of their way if needed. Do not focus on the display panel for extended periods of time while riding.
- **NEVER** ride at a speed where your stopping distance exceeds your visibility. We do not recommend that you ride your tricycle at night or in an environment with poor visibility. If you have an emergency that makes it necessary to do so, keep your light on and limit your speed appropriately.
- **NEVER** use the throttle or pedal assist system (PAS) in any situation, road condition, or terrain where doing so might impair your control of your tricycle.
- **DO NOT** load this tricycle with more than 330 pounds (150 kilograms).

- **ALWAYS** avoid direct pressurized spray that might allow the interior of the battery, display panel, front light, and other electronic components to become wet. If the interior of the battery accidentally becomes wet, replace it with a new identical one. For the other electronic parts, wait for them to completely dry before any further use.
- **ALWAYS** turn the battery off between uses. For best results, also disconnect the plug from the battery socket. Always fully remove the battery from this tricycle before performing any cleaning, servicing, and storage.
- **NEVER** place the battery near heat sources or explosive or flammable gases. Never expose it to radiation or excessive pressure. Only charge the battery in locations with an ambient temperature between 32° and 113°F (0–45°C).
- **NEVER** modify the battery or power cord. Only use the provided charger with this tricycle. Never get the charger or power cord wet or operate them with wet hands.
- If the battery is ever damaged, avoid all contact with it or any leaking fluid. Remove contaminated clothing and flush with copious amounts of water if contact accidentally occurs with the skin. If contact accidentally occurs with the eyes, **IMMEDIATELY** flush them with copious amounts of water for at least 15 minutes while seeking medical attention.

Specifications

Motor Power		250 W	
Battery	Type	36V Lithium	
	Weatherproofing	IP64	
	Operational Temp. Range	-4 to 140°F	-20 to 60°C
	Charging Temp. Range	32 to 113°F	0 to 45°C
	Optimal Storage Temp. Range	-4 to 77°F	-20 to 25°C
Display Panel	Weatherproofing	IP55	
Front Light	Weatherproofing	IPX4	
Weight Capacity		330 lb.	150 kg
Max. Speed		15.5 mph*	25 km/h*

* Based on unloaded wheel rotation at full power without friction. True maximum speed will vary according to variables such as battery strength and load but should remain ±1 mph of the preset value.

Product Diagram

Overview

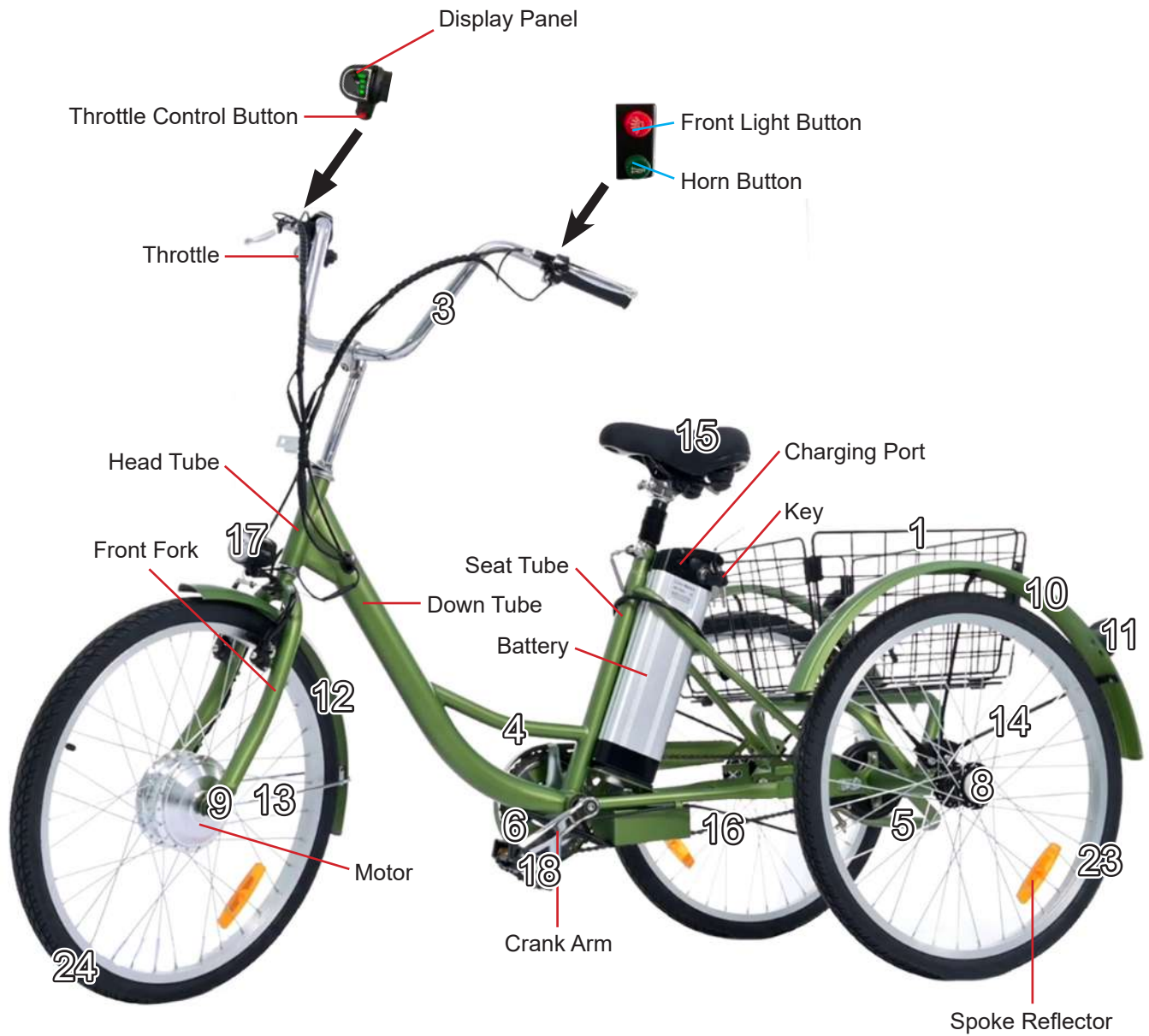

Parts



Item	Name	Qty.
1	Basket	1
2	Long Bolts & Nuts	2
3	Handlebars	1
4	Main Frame with Battery & Keys	1
5	Rear Frame	1
6	Chain Guard	1
7	Zip Ties	2
8	Rear Wheel Caps	2
9	Front Wheel Cap	1
10	Rear Fenders	2
11	Rear Reflectors	2
12	Front Fender	1
13	Front Fender Stay	1
14	Rear Fender Stays	2

Item	Name	Qty.
15	Saddle	1
16	Chain	1
17	Front Light	1
18	Pedals	2
19	Short Bolts & Nuts	6
20	Connecting Plate	1
21	Spring	1
22	Slats	2
23	Rear Wheels	2
24	Front Wheel	1
25	Charger	1
26	Power Cord	1
27	Multitool	1
28	Multifunctional Wrench	1

Not Included but Necessary or Recommended:

- 18mm Wrench
- 22mm Wrench
- Pliers

For your convenience, all bolts, nuts, and washers except some for the basket and the fenders are preinstalled where they will be needed. During assembly, simply remove the fasteners as needed and keep them nearby. Reinstall them to connect each part as you go and tighten them securely for a safe and satisfactory experience.

Assembly

To see these instructions in video form, go to our YouTube channel **Viribus Bikes** and search for “Electric Tricycle with Rear Basket, AAE-1”.

Note: Any holes or slots on the tricycle that are not specifically mentioned herein do not require any additional fasteners or special treatment during the assembly process.

1. Installing the Rear Wheels

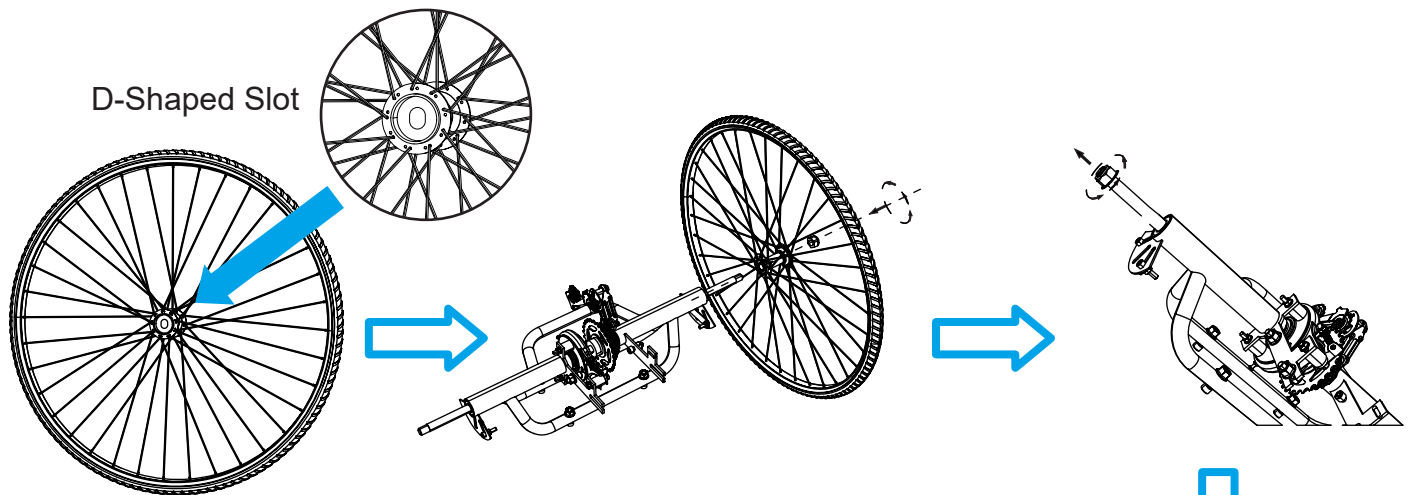

 The two rear wheels (23) **ARE** different and should **NOT** be mixed up. The wheel with the D-shaped slot goes with the D-shaped hub on the right side of the rear axle while the wheel with the O-shaped slot goes with the O-shaped hub on the left side.

1. Remove the M14 nut and 2 washers from the D-shaped hub on the right side of the rear frame (5) by hand. Place them nearby.
2. Insert the wheel with the D-shaped slot onto the D-shaped hub.
3. Replace the washers and nut, tightening the nut with a 22mm wrench (not included).
4. Remove the M14 nut and 2 washers from the O-shaped hub on the left side. Place them nearby.
5. Insert the wheel with the O-shaped slot onto the O-shaped hub.
6. Replace the washers and nut, tightening the nut in the same fashion.

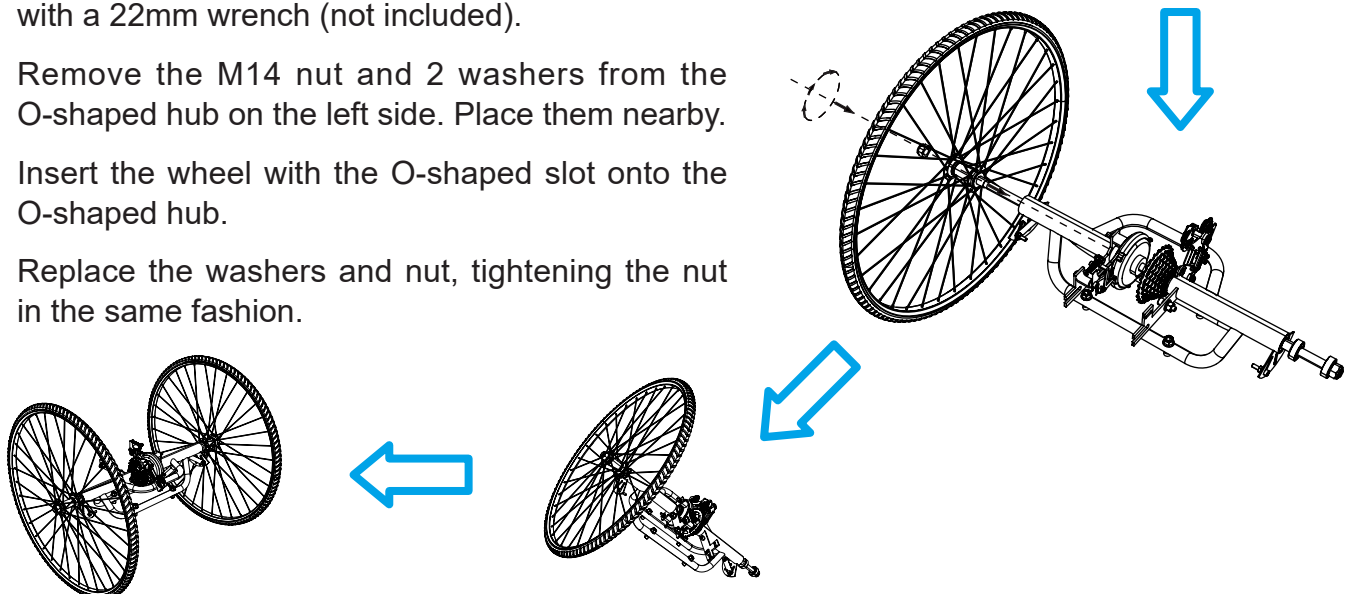
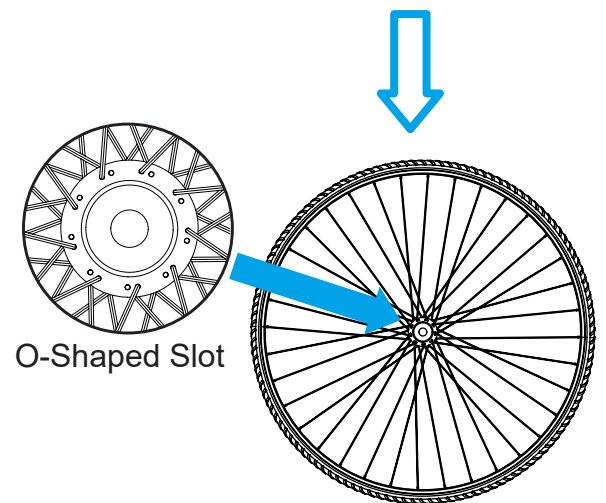

2. Connecting the Rear and Main Frames

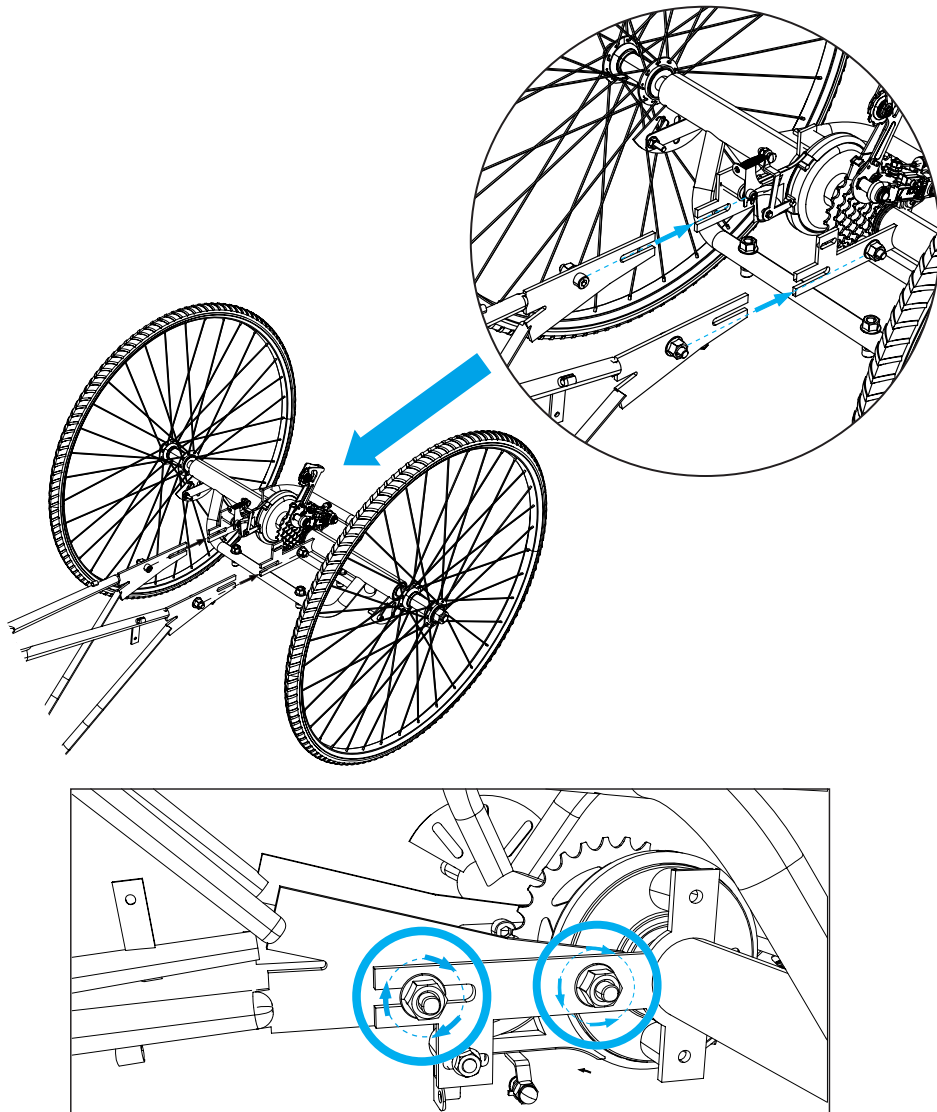

1. Remove the 2 sets of M10 nuts from both sides of the main frame (4) with the multifunctional wrench (28) and then remove their bolts and washers by hand. Place them nearby.
2. Loosen the 4 sets of M10 nuts and bolts on both sides of the rear frame.
3. Align the slots of the frames with each other, sliding the rear frame onto the main frame as shown. For best results, start with either side and repeat for the other side.
4. Replace the removed washers, bolts, and nuts onto the main frame.
5. Partially tighten these bolts and nuts on both frames. (Fully tighten them later after chain installation.)

3. Installing the Front Wheel

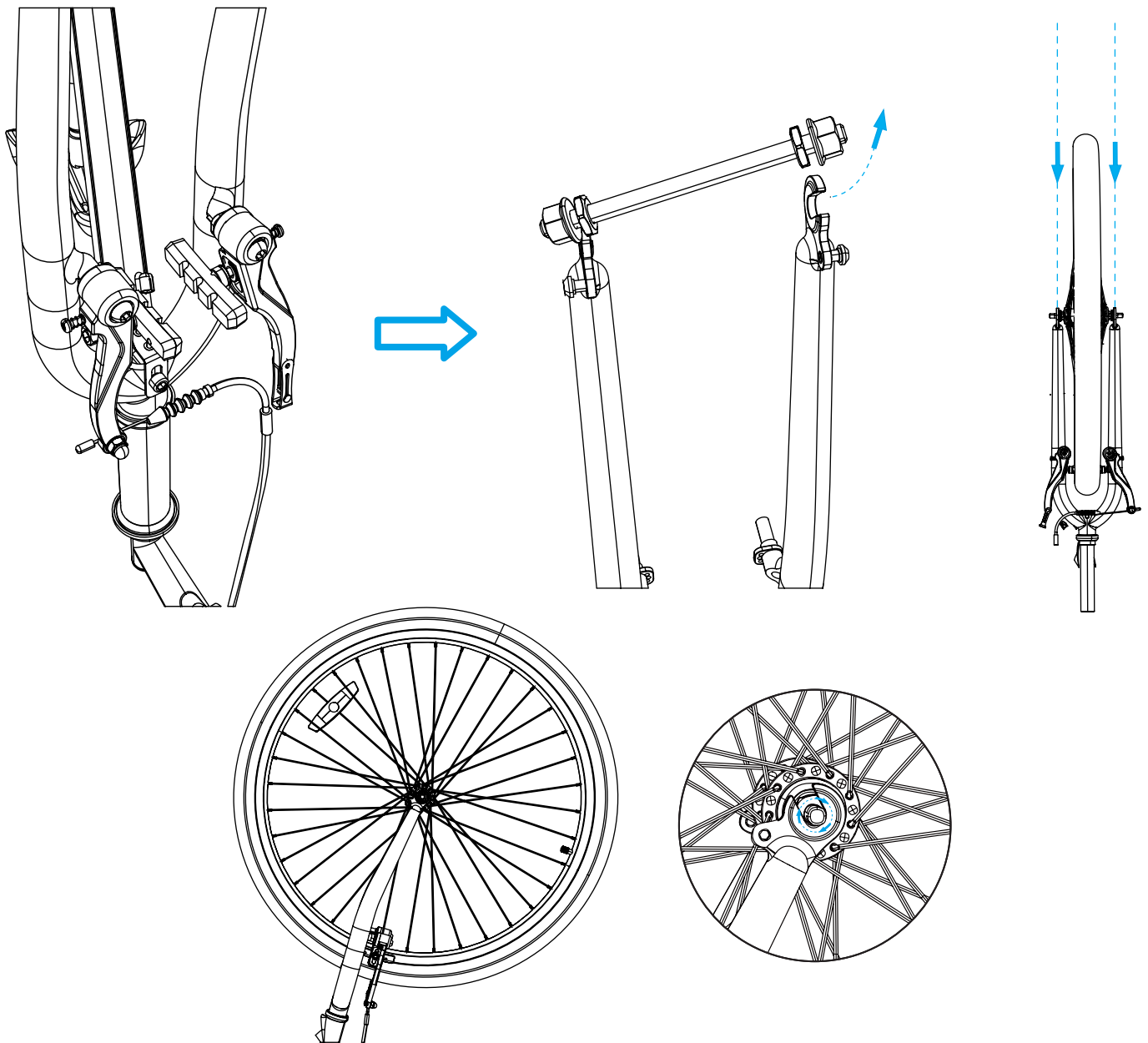

1. Loosen the M12 nuts on both sides of the motorized front wheel (24) by hand.
2. Press and disconnect the V-shaped front brake on the main frame's front fork.
3. Unscrew the locking nuts on the protective bar and remove the bar from the front fork.
4. Fit the front wheel into the front fork, keeping the motor cable on the right and allowing the fork to catch the wheel's axle snugly.
5. Retighten the nut on the right with an 18mm wrench (not included), covering it with the attached cap.
6. Remove the protective cover and connect the wiring between the motor and the handlebars.
7. Arrange the wiring neatly throughout the slots along the front fork.
8. Retighten the nut on the left side of the front wheel.

4. Installing the Handlebars

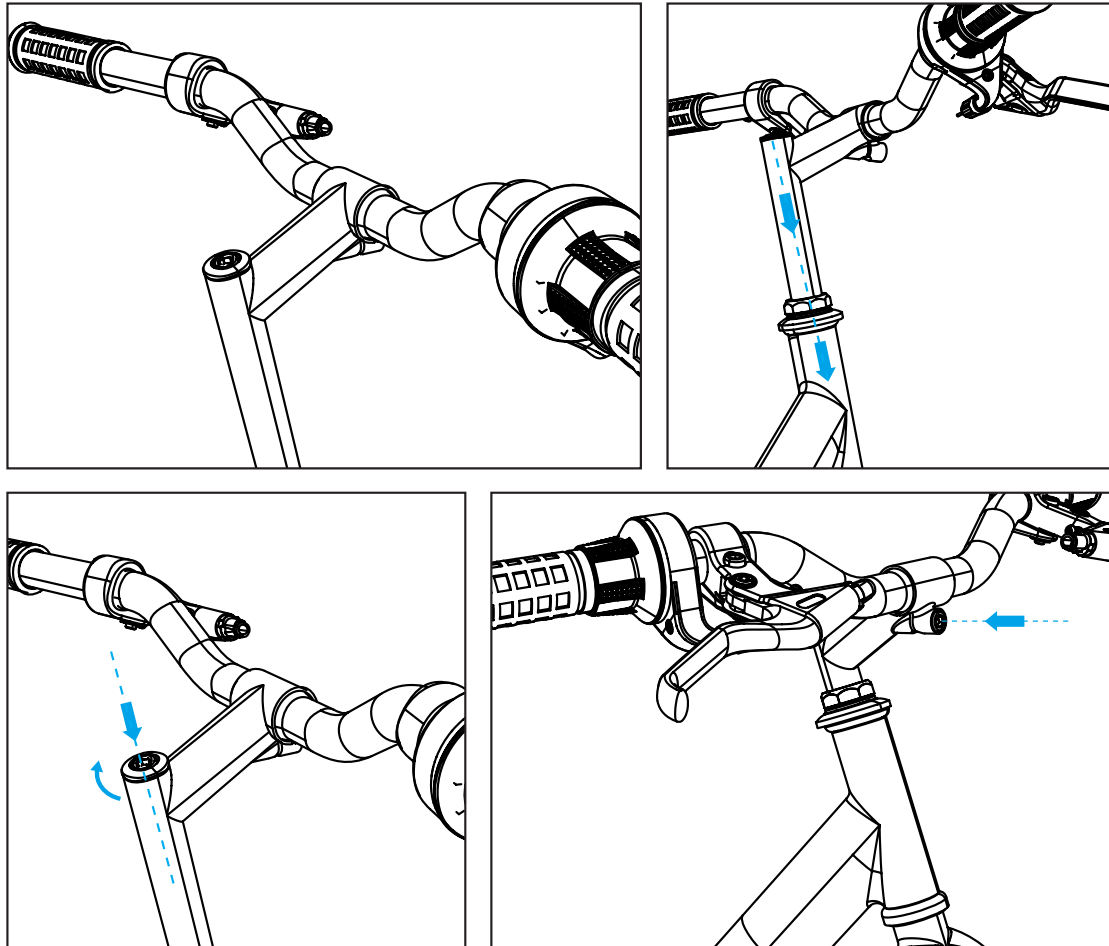

1. Remove the protective cover underneath the stem of the handlebars (3).
2. Loosen the M8 bolt at the top of the stem with the 6mm hex wrench on the multitool (27).
3. Slide the stem into the head tube of the main frame, retightening this bolt.
4. Loosen the M8 bolt on the front of the stem in the same fashion.
5. Raise the handlebars to your preferred position and then retighten the front bolt.
6. For best results, bind the cables using the zip ties (7).

5. Installing the Chain



1. Fit the chain (16) around the front and rear sprockets.
2. Join both ends of the chain, jamming the pin into the slot with pliers (not included) as shown. Ensure that the chain is completely connected and flush.
3. Test that the chain moves freely by rotating the right crank arm.
4. Confirm that the chain remains a little loose. If needed, loosen the M10 bolts and nuts connecting the rear and main frames with the multifunctional wrench.
5. Push the main frame forward until the chain is taut and then tighten the M10 nuts and bolts on both frames completely.

6. Installing the Chain Guard

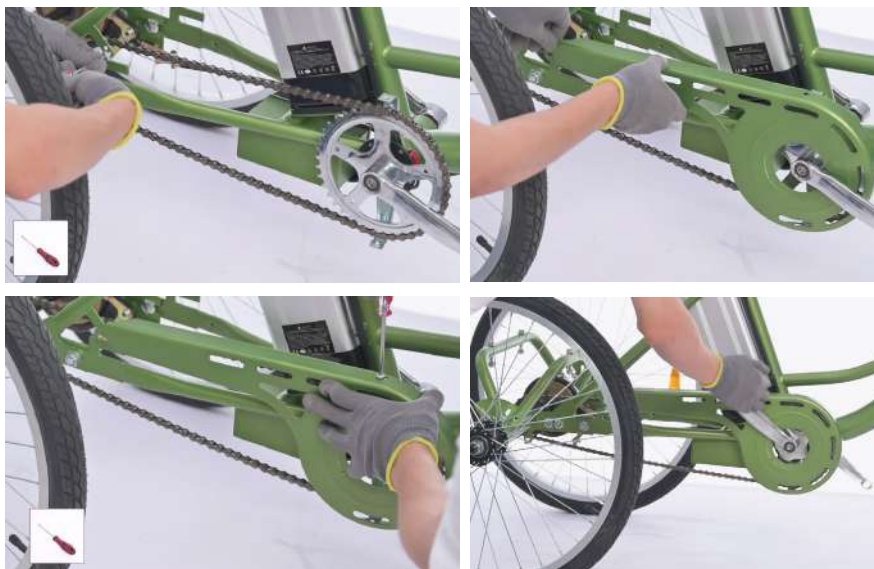

1. Remove the 3 bolts from the guard supports near the front and rear sprockets with the Phillips screwdriver on the multitool. Place them nearby.
2. Place the chain guard (6) onto its supports and over the chain as shown.
3. Replace and retighten the bolts.
4. Rotate the chain to confirm it does not rub against the guard. If it does, readjust the guard so that the chain can move freely.

7. Installing the Saddle

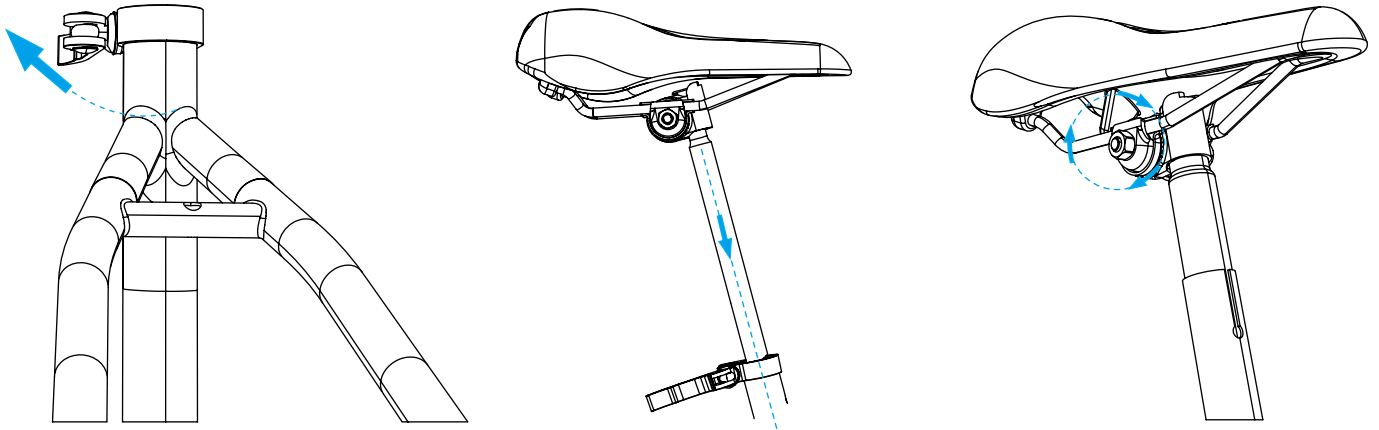

1. Loosen the locking bolt on the seat tube of the main frame by turning its handle counterclockwise.
2. Insert the post of the saddle (15) into the tube until your preferred height is reached.
3. Retighten the locking bolt by turning its handle clockwise.
4. To adjust the saddle forward or backward, loosen the two nuts underneath the saddle using the multifunctional wrench, slide the saddle on its support frame until your desired position is reached, and retighten the nuts. Confirm they hold tight and the saddle does not show any wobble.

8. Installing the Pedals

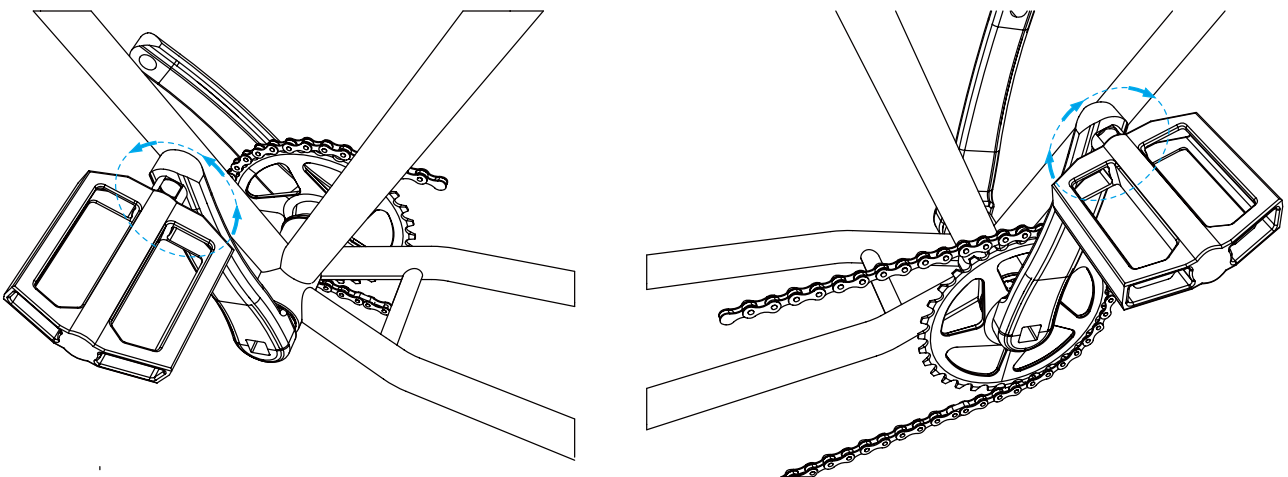

The two pedals **ARE** different and should **NOT** be mixed up. The right pedal is marked with an **R** and the left with an **L**.

1. Attach the pedals (18) to the crank arms on the appropriate side, screwing them into place.
2. Tighten their locking nuts with the 15mm wrench on the multitool.
3. Test that the chain turns smoothly while using the pedals. Adjust as needed.

9. Installing the Rear Reflectors



 The two rear reflectors are the same. They can be used on either rear fender.

1. Remove the nut from the bolt on one rear reflector (11) by hand. Place it nearby.
2. Attach the rear reflector to a rear fender (10).
3. Replace and tighten the nut. For best results, use your pliers.
4. Install the other rear reflector following the same steps.

10. Installing the Rear Fenders and Stays

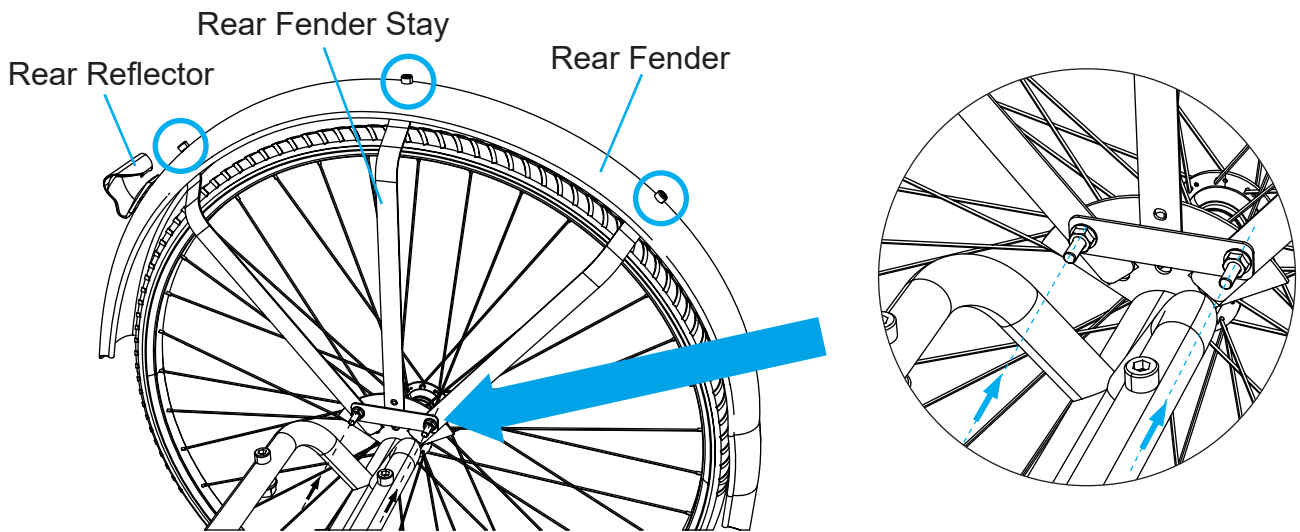

 The rear fenders and stays can be used on either side.

1. Unfold one rear fender stay (14), aligning its three upper holes with those on a rear fender.
2. Connect the fender stay to the fender with the provided short bolts and their nuts (19).
3. Tighten these bolts with the Phillips screwdriver on the multitool and tighten their nuts by hand or with pliers.
4. Remove the 2 bolts from either side of the rear frame using the Phillips screwdriver on the multitool and remove their washers and nuts by hand. Place them nearby.
5. Fit the rear fender over a rear wheel, aligning the fender stay's bottom holes with the slots on the rear frame.
6. Replace the washers, bolts, and nuts, partially tightening the bolts and nuts by hand.
7. Lift the rear fender to provide extra space.
8. Tighten the bolts completely and tighten the nuts completely with the 10mm wrench on the multitool.
9. Install the other rear fender and stay following the same steps.

11. Installing the Front Brake, Fender, Light, and Stay



1. Remove the bolts from the connecting plate (20) by hand and disconnect its upper and lower parts. Place them nearby.
2. Mount the front fender stay (13) onto the front fender (12) using the upper part.
3. Replace the bolts onto the upper part, passing through the holes on the fender.
4. Connect lower part to the bolts from the opposite side of the fender as shown.
5. Tighten these bolts with the Phillips screwdriver on the multitool.

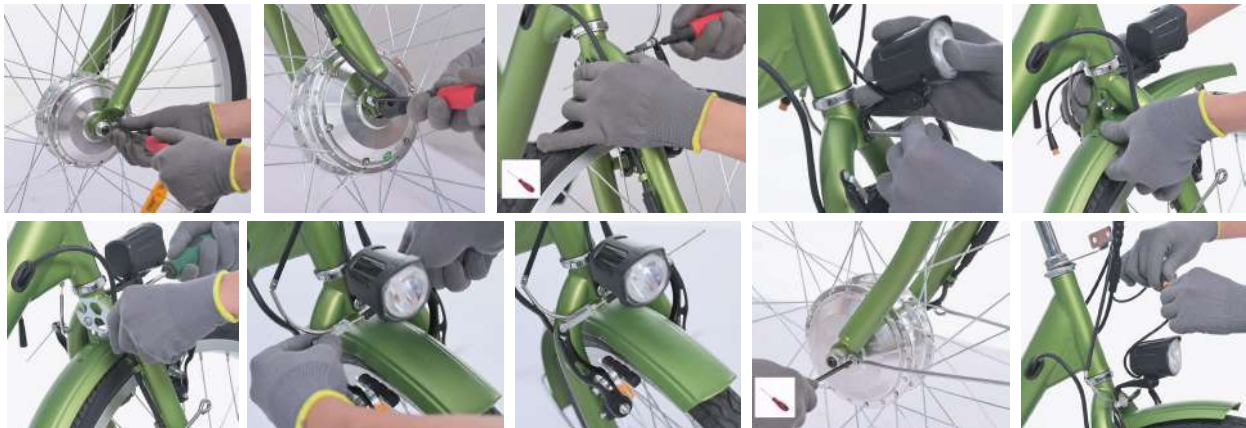

6. Remove the small bolts from the front fork's tips with the Phillips screwdriver on the multitool. Place them nearby.
7. While holding the nut at the top of the front fork with the multifunctional wrench, loosen its long bolt with the Phillips screwdriver on the multitool and then remove the nut, bolt, and their washer by hand. Place them nearby.
8. Place the front light (17) onto the top of the front fork, aligning their slots and replacing the long bolt.
9. Fit the front fender over the front wheel, aligning its top hole with the front fork's as shown.
10. Replace the washer and nut, partially tightening the long bolt and nut.
11. Position the brake pads over the front wheel's rim. (Do not allow them to touch the tire.)
12. Tighten the pads' bolts with the 5mm hex wrench on the multitool.
13. Fit the front brake cable into the slot of the other side of the V-shaped front brake, pulling it taut.
14. Turn the front fender stay, aligning its holes with those on the front fork's tips. Adjust its shape if needed.
15. Replace and tighten the small bolts.
16. Tighten the long bolt and its nut completely.
17. Test the front brake by pressing the left brake handle.
18. Connect the yellow banded cable to the light.

12. Installing the Rear Brake

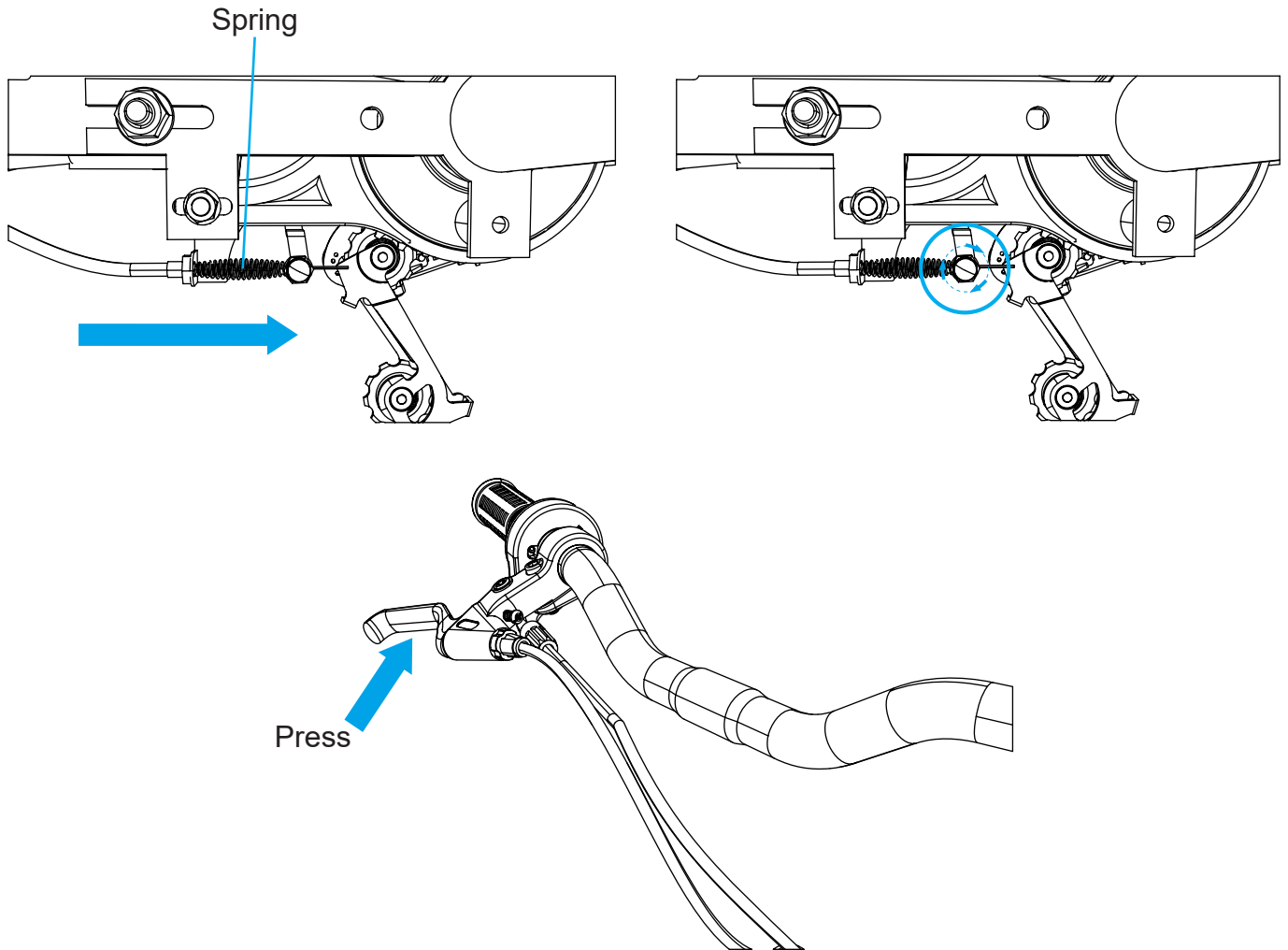

1. Place the spring (21) between the rear brake cable support and the locking bolt on the rear frame.
2. Feed the rear brake cable through the support, spring, and bolt.
3. Press the bolt, tightening its nut with the 10mm wrench on the multitool.
4. Test the rear brake by pressing the right brake handle.

13. Installing the Basket



 For best results, use work gloves to prevent injury.

1. Unfold the basket (1) and align the slots on the edge of each side as shown.
2. Connect the sides using the provided long bolts and their nuts (2).
3. Tighten the nuts by hand.

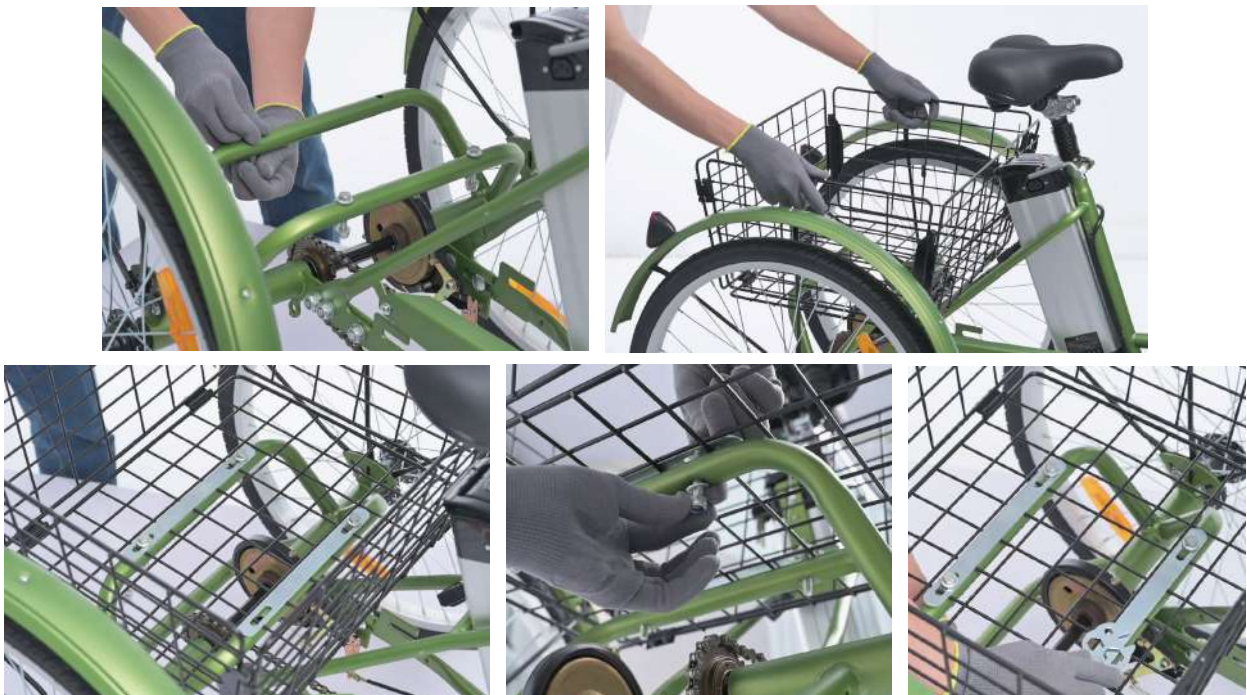

4. Remove the 4 sets of nuts, washers, and bolts from the rear frame by hand.
5. Fit the basket onto the rear frame, placing the slats (22) into the basket where their bolt holes are aligned with those on the rear frame.
6. Replace these fasteners, tightening the M8 nuts with the multifunctional wrench.

14. Installing the Wheel Caps



1. Attach the rear wheel caps (8) to the rear wheel hubs, pressing hard until they are locked in place.
2. Attach the front wheel cap (9) to the left side of the front wheel hub, pressing or tapping until it becomes secure.

Operation

Activating and Deactivating the Battery



 Your battery was charged at the factory but may have run down during shipping. Check the battery's remaining power for the first use and refill it using the provided charger as described in the Charging section below.

1. Insert the attached power plug into the socket on the right side of the battery.
2. Unfasten the keys from beside the battery and insert one into its socket on the left side of the battery.
3. To activate the battery, turn the key clockwise to "ON". The display panel on the right handlebar should turn on, displaying the remaining power of the battery.
4. To deactivate the battery, turn the key counterclockwise to "OFF" and the display panel will turn off.

 Always turn the battery off between uses and remove the key to prevent unauthorized use.

Riding with Pedal Assist Control

The pedal assist system (PAS) is available when the battery and display panel are on, which requires you to continue using the pedals to keep the motor active but provides additional speed and strength as you ride. To use PAS only, it is recommended to disable the throttle by pressing the red button below the display panel on the right handlebar.

The PAS automatically pauses and the motor temporarily shifts to neutral in the following cases:

- You stop pedaling
- You press either brake lever
- Your tricycle accelerates on a slope to a speed faster than the 15.5 mph (25 km/h) top speed

The PAS reactivates once both brakes are released, your speed is at or below the top speed, and you resume pedaling.

If you turn the throttle while PAS is active, the tricycle will activate throttle control and accelerate to its top speed, unless the throttle is already disabled as mentioned above. If you turn off the battery while PAS is active, the motor will stop and the tricycle will only operate manually.

 We do not recommend you shut off the battery while riding the tricycle, as this distraction can invite accidents.

Riding with Throttle Control

The throttle control is available when the battery and display panel are on, enabling your tricycle to run at the 15.5 mph (25 km/h) top speed using the throttle handle on the right handlebar. Turn the throttle handle, stop pedaling the tricycle, and your tricycle will continue along at the top speed. If necessary, hit the red button below the display panel to disable the throttle, cutting off the power immediately even if the throttle handle is not released.

 The tricycle will not exceed its top speed on flat pavement but may do so on slopes.

Throttle control automatically pauses and the motor temporarily shifts to neutral in the following cases:

- You release the throttle handle completely
- You press either brake lever
- You accelerate beyond the 15.5 mph (25 km/h) top speed
- You disable the throttle as mentioned above, even without releasing the throttle handle

The motor will resume working once the throttle handle is turned again, both brakes are released, your speed is at or below the top speed, or the throttle handle is reactivated while it is turned after the aforesaid red button is pressed again.

If you begin pedaling while the throttle control is active, the tricycle will activate PAS control. If you turn off the battery while throttle control is active, the motor will stop and the tricycle will only operate manually.

 We do not recommend you shut off the battery while riding the tricycle, as this distraction can invite accidents.

Ride with Manual Control

To ride your tricycle normally, leave the key at “OFF” on the battery or remove the battery. (See Steps 1–2 in the Charging section below for how to remove the battery.)

Charging

In addition to the handlebar display, your tricycle's current power level can be checked on the battery itself. Press the power display button and see how many of the battery's indicator lights turn on. 3 lights indicate a full battery, while 1 light indicates a weak one.

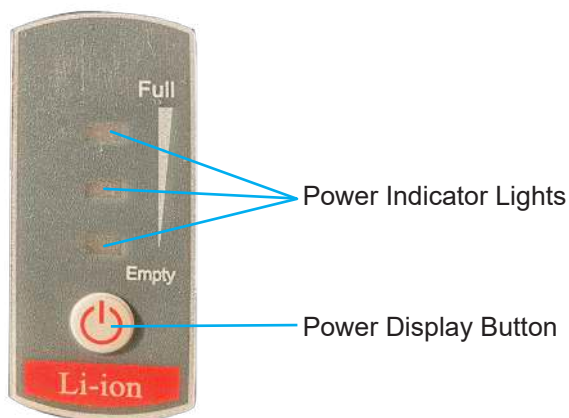

When you find that recharging is necessary,

1. Unlock the battery by turning the key counterclockwise to "Unlock".
2. Remove the battery from the tricycle.
3. Connect the provided charger (25) to its power cord (26) and the charging port beside the battery's key hole.
4. Connect the charger to a stable and compatible power source. The charger's power indicator light should turn red and charging should begin.
5. Periodically check the state of the battery with the power display button. There is no need to fully recharge the battery. Either 2 or 3 lights should provide strong and responsive service. For best results, however, do not allow the battery to ever drain completely and avoid leaving it connected to power once it is already charged.



Maintenance

- Always disconnect the battery before undertaking any cleaning, maintenance, or repair. For the longest possible service life, disconnect the battery between uses.
- Check the parts of the tricycle for any looseness, stiffness, wear, or damage after each use. Tighten, lubricate, repair, or replace any problematic parts before further use. Only replace components of this tricycle and its accessories with identical parts.
- The exterior of the tricycle can be cleaned with a soft damp cloth. Do not use harsh abrasives or caustic chemicals. All electronic components have waterproofing adequate for rain, but avoid direct pressurized spray that might allow the interior of electronic components to become wet, never charge the battery while it or your hands are wet, and immediately replace the battery if it ever begins to swell or leak fluid.
- If the tricycle will not be used for an extended period of time, remove the battery and store everything in a cool dry place away from direct sunlight and inaccessible to children. Avoid storing electronics in plastic bags, which might allow humidity to build up over time. For best results, check the battery every three months. If its power sinks below $\frac{2}{3}$ (2 of the 3 indicator lights), recharge to at least that full before returning it to storage.

Contact Us

Thank you for choosing our products! If you have any questions or comments, contact us at help@cs-supportpro.com and we'll resolve your issue ASAP!

For a .pdf copy of the latest version of these instructions, use the appropriate app on your smartphone to scan the QR code to the right.



AAE - 1 LAB - AB
AAE - 1 LAB - AG
AAE - 1 LAB - AK
AAE - 1 LAB - AR
AAE - 1 LAB - AW
AAE - 1 MAB - AB
AAE - 1 MAB - AG
AAE - 1 MAB - AK
AAE - 1 MAB - AP
AAE - 1 MAB - AR
AAE - 1 MAB - AW
Rev. 26 Feb. 2024