

Choosing the Right Lutron Thermostat Control

Overview

HVAC control is one of the primary benefits of the Lutron Residential Systems offering. Lutron thermostat controls improve the overall efficiency of a home and enhance temperature control. Basic knowledge of a HVAC system is helpful in choosing the correct Lutron thermostat control for each application.

This document outlines recommended processes for determining which Lutron thermostat control is best suited for a particular application. These processes help identify various resources that can aid in the decision making process and serves to define key terms in the HVAC industry.

Table of Contents

New Construction or Retrofit Application	2
Identifying HVAC Equipment	3
Locate the HVAC Equipment Installation Manual	4
Find the Existing Thermostats and Check the Connections Used	6
Read the Installation Manual for the Recommended Thermostats	7
Number of HVAC Zones	8
Features Desired By the End User	9
Glossary of Key Terms	10
Frequently Asked Questions (FAQs)	12
Appendix A - L-HWL2-WIFI Diagram	13
Appendix B - Nest Learning Thermostat Diagram	14
Appendix C - HomeWorks QS Palladiom Thermostat Diagram	15
Appendix D - Common Heating Systems in the U.S.A.	16

New Construction or Retrofit Application

Most Lutron thermostat control solutions can be easily installed in a new construction or retrofit application. If the Lutron thermostat control is to be installed in a retrofit application, there are no pre-install considerations since everything is typically installed already. If this is the case, skip to [Find the Existing Thermostats and Check the Connections Used](#). Continue with this section if the application is either new construction or if the HVAC equipment is being replaced.

New construction is convenient because the walls are open and easily accessible. Ensure that the proper wire size and number of conductors are run from the HVAC equipment to the thermostat locations. Lutron thermostats use 18 AWG to 22 AWG (1.0 mm² to 0.5 mm²) solid wire. In an application where a heat pump will be used or there is a strong possibility of one being used, make sure that 7 conductors are installed. In all other cases, make sure 5 conductors are installed. Run all wires to the location where the thermostat will be mounted. Verify that the technician completing the wiring follows the specifications mentioned above.

The HVAC controller (LR-HVAC-1-WH) and the HomeWorks QS Palladiom HVAC controller (e.g. SMC55-RESI, SMC55-HWQS, SMC55-RESI-2) are typically mounted with the HVAC equipment so the wire runs between those devices and the HVAC equipment are usually short.

The TouchPRO Wireless thermostat (LR-HWLV-HVAC) and Lutron wireless thermostat (L-HWLV2-WIFI) have integrated temperature sensors. Like a typical thermostat, they are often wired in the living space and require longer wire runs. Remote mounting options are available via remote temperature sensors.

Having the correct number of conductors will ensure that there is enough wire to use either of the 24 V~ Lutron control options. LR-HVAC-1-WH, SMC55-RESI/SMC55-HWQS/SMC55-RESI-2, LR-HWLV-HVAC, and L-HWLV2-WIFI all require a common wire connection.

This document will help to compare and contrast all of Lutron control solutions in order to help identify the right choice for every application.

LR-HVAC-1-WH

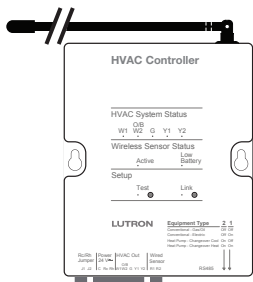

SMC55-RESI/SMC55-HWQS/SMC55-RESI-2 with HomeWorks QS Palladiom Thermostat (HQWT-T-HW)

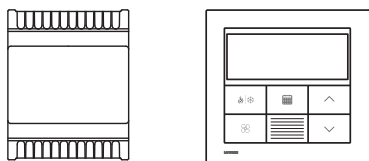

LR-HWLV-HVAC

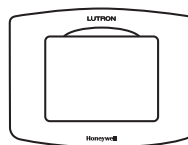

L-HWLV2-WIFI

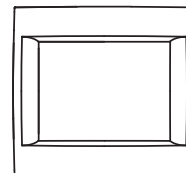

Continued on next page...

Identifying HVAC Equipment

There are a number of methods to identify the type of HVAC equipment that is used in an application. Regardless of the method, identifying the HVAC equipment is the most important part of determining which Lutron thermostat control should be used in the application.

HVAC Equipment	Compatible?			
	LR-HVAC-1-WH	SMC55 Controller	LR-HWLV-HVAC	L-HWLV2-WIFI
Single stage cool	Yes	Yes	Yes	Yes
Two stage cool	Yes	Yes	Yes	Yes
Single stage heat	Yes	Yes	Yes	Yes
Two stage heat	Yes	Yes	Yes	Yes
Packaged rooftop units	Yes	Yes	Yes	Yes
Heat pump	Yes	Yes	Yes	Yes
Dual fuel systems	Yes	No ³	Yes	Yes
Geothermal heat pump	Yes	No ³	Yes	Yes
Heat pump with auxiliary electric heat (emergency)	Yes	Yes	Yes	Yes
Typical variable speed fan (equipment controlled)	Yes	Yes	Yes	Yes
Multi-zone systems (controllable dampers)	Yes ¹	Yes ¹	Yes ¹	Yes ¹
In-floor radiant heat	Yes	Yes ⁷	Yes	Yes
Line voltage electric baseboard	No	No	No	No
Millivolt system	No	No	No	No
Proprietary/digital control system	No	No	No	No
Variable speed fan (independent relays)	No	Yes ⁴	No	No
Humidity sensing	No	No ³	No	Yes
Humidification control	No	No	No	Yes
Dehumidification control	No	No ³	No	Yes
Ventilation control	No	No	No	Yes
Remote temperature sensor	Yes	Yes	Yes ²	Yes ²
Outdoor temperature sensing	No	No	Yes ²	Yes ²
Variable refrigerant (VRV/VRF)	Yes ⁵	Yes ⁶	Yes ⁵	No

¹ Requires a 3rd party control.

² Remote sensor is a Honeywell sensor.

³ Not currently compatible but will be available soon.

⁴ Fan Coil Unit (FCU) control only.

⁵ Requires a 3rd party control. See Application Note #646 (048646) at www.lutron.com

⁶ Requires a 3rd party control. See Application Notes #585 (048585), #627 (048627), and #650 (048650) at www.lutron.com

⁷ Included with SMC55-RESI version 7302 or newer.

Continued on next page...

Identifying HVAC Equipment (continued)

Locate the HVAC Equipment Installation Manual

The installation manual for the HVAC equipment will help to identify the following important information:

- Type of equipment (e.g., heat pump, gas furnace, A/C)
- Number of stages
- Control wiring (thermostat to HVAC equipment wiring)

To find a printed version of the installation manual, scan the area around the equipment or look for a protective pocket on the actual equipment. If the installation manual cannot be found, obtain the manufacturer and a model number of the equipment. Use this information to search for the installation manual online.

See **Figure 1** for examples of installation manuals for HVAC equipment. The equipment type and number of stages are identified on the first page.

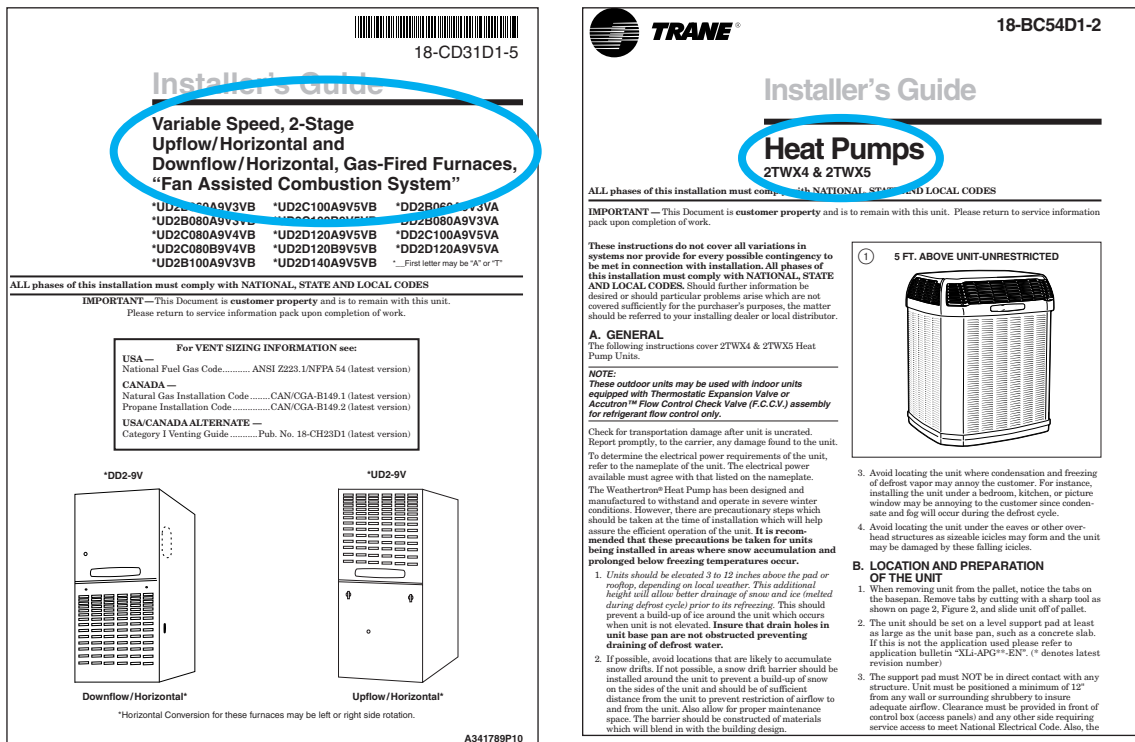

Figure 1 - Equipment Type Examples

Continued on next page...

Identifying HVAC Equipment (continued)

Locate the HVAC Equipment Installation Manual (continued)

Control wiring is normally found deeper into the installation manual. The installation manual will demonstrate how to connect the equipment to indoor thermostats. The connections that the thermostat requires will indicate the potential for a Lutron thermostat control to be used as an alternative in the same application. The wire connections will also reveal if the system uses a proprietary communication protocol between the controls and the HVAC equipment. If this is the case, the use of any Lutron or 3rd party alternative is ruled out. See below for examples of connection diagrams in installation manuals.

Figure 2 displays typical thermostat connections from the HVAC equipment to the control.

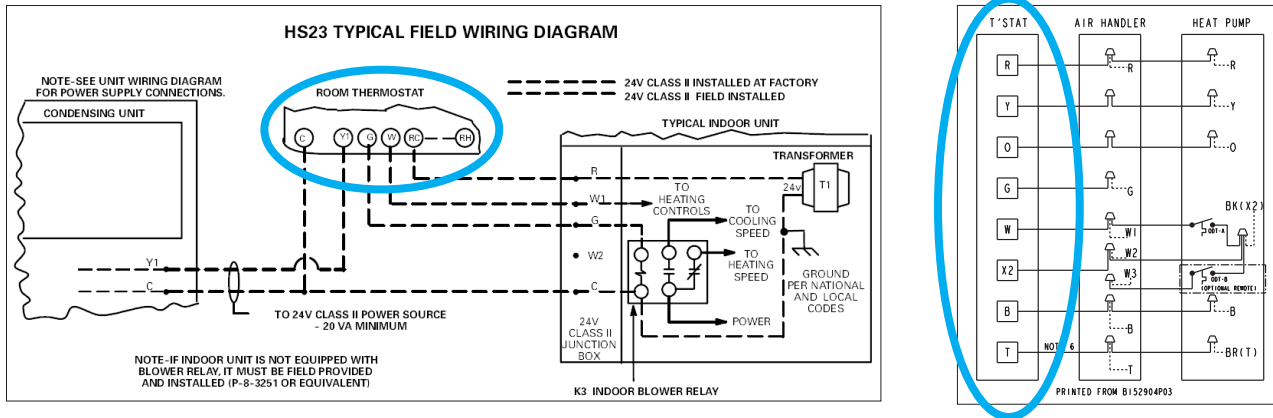

Figure 2 - Example Wiring Diagrams (standard)

Figure 3 shows an example of an air conditioner/heat pump that has the capability of using a proprietary communication protocol between the HVAC equipment and a special control unit. Since this uses a proprietary communication protocol over terminal D, the Lutron thermostat control would not be able to control this application directly. In some cases, as with the equipment featured below, an auxiliary device can be added for the implementation of standard 24 V, non-proprietary controls such as Lutron thermostats. It is important to determine if this is the case before proceeding and it will often be noted in the installation manual for the HVAC equipment.

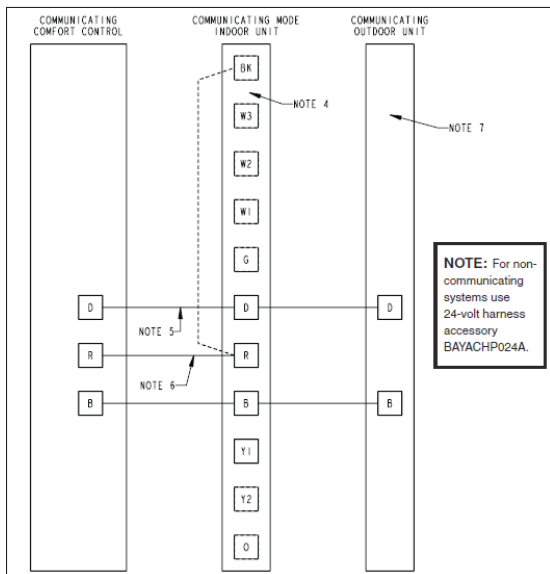

Figure 3 - Example Wiring Diagram (proprietary, not compatible)

Continued on next page...

Identifying HVAC Equipment (continued)

Find the Existing Thermostats and Check the Connections Used

This section is applicable in a remodel/retrofit application. Remove the thermostat from the wall to expose the wire connections on the rear of the thermostat. Take note of the connections being made and then reference those connections in the table below. The table contains the common terminal designations for HVAC controls and the equivalent Lutron thermostat control connections. For more information about specific terminology, refer to [Glossary of Key Terms](#).

Terminal Description	Terminal	LR-HVAC-1-WH	SMC55 Controller	LR-HWLV-HVAC	L-HWLV2-WIFI
Thermostat power or heat only transformer	R or R _H	R _H	R _H	R	R
Thermostat power or cool only transformer	R _C	R _C	R _C	R _C	R _C
Single or first stage cooling	Y	Y ₁	Y ₁	Y	Y
Second stage cooling	Y ₂	Y ₂	Y ₂ ⁶	Y ₂	Y ₂
Single or first stage heating	W	W ₁	W ₁	W	W
Second stage heating	W ₂	W ₂	W ₂ ⁶	W ₂	W ₂
Fan relay	G	G	G	G	G
Fan relay [for Fan Coil Units (FCUs) only]	G ₁ , G ₂ , G ₃	n/a	G ₁ , G ₂ , G ₃	n/a	n/a
Common ¹	C	C	C	C	C
Changeover/reversing valve ^{2,3}	O/B	W ₂	O/B ⁶	O/B	O/B
Emergency heat	E	W ₁	R _{AUX} , AUX ⁶	AUX/E	AUX/E
Auxiliary heat	X or AUX	W ₁	R _{AUX} , AUX ⁶	AUX/E	AUX/E
Remote/outdoor temperature sensor	S ₁ or Outdoor 1	R ₁	Blue wire (conventional) Black wire (common)	S ₁	S ₁
Remote/outdoor temperature sensor ^{4,5}	S ₂ or Outdoor 2	R ₂	Blue/red wire (FCU changeover) Black wire (common)	S ₂	S ₁
Universal relay for humidification/dehumidification/ventilation	U ₁	n/a	n/a	U ₁	U ₁

¹ Common wire connection is necessary for every application.

² "O" is used for most heat pumps. It provides power for changeover/reversing valve in cooling mode.

³ "B" is used in Rheem or Ruud systems. It provides power for changeover/reversing valve in heating mode.

⁴ Outdoor temperature sensor not supported with LR-HVAC-1-WH.

⁵ Sensor connection requires both terminals. It is not a single terminal connection.

⁶ Included with SMC55-RESI version 7302 or newer.

Continued on next page...

Identifying HVAC Equipment (continued)

Read the Installation Manual for the Recommended Thermostats

Reading the installation manual for recommended thermostats is especially useful for new construction applications. A retrofit application often has a thermostat in the space that can be used to verify the connections. New construction applications do not have a thermostat installed and will not have limitations based on wiring as with retrofit applications.

In the HVAC equipment installation manuals and specification sheets, the thermostats that are recommended are typically from the same manufacturer. This can lead to the assumption that only their thermostats can be used, perhaps as a result of a proprietary communication protocol. Despite the recommendation, it is typically not a requirement and 3rd party thermostats can often be used. However, it is still prudent to consult an HVAC specialist or contact the HVAC equipment manufacturer's technical support before proceeding.

The best practice is to consult an HVAC specialist, look up recommended thermostats, and browse the thermostat installation manual for HVAC equipment wiring diagrams.

In **Figure 4**, the installation manual refers to document T11-001 which can be found online. If a specific reference document is not mentioned in the installation manual, an online search can be completed to determine if that document exists.

Thermostats



200-Series*
Programmable



300-Series*
Deluxe
Programmable



400-Series*
Special
Applications/
Programmable



500-Series*
Communicating/
Programmable

Brand	Descriptor (3 characters)	Series (3 characters)	System (2 characters)	Type (2 characters)
RHC	-	TST	213	UN
RHC = Rheem	TST = Thermostat	200 = Programmable 300 = Deluxe Programmable 400 = Special Applications/Programmable 500 = Communicating/Programmable	GE = Gas/Electric UN = Universal (AC/HP/GE) MD = Modulating Furnace DF = Dual Fuel CM = Communicating	SS = Single Stage MS = Multi-Stage

*Photos are representative. Actual models may vary.

For detailed thermostat match-up information,
see specification sheet form number T11-001.

Figure 4 - Example of Recommended Thermostat

Number of HVAC Zones

It is important to verify how many zones are in the HVAC system. In a retrofit application, this can easily be done by counting the number of thermostats currently installed. This is important to determine the right Lutron control for the application.

As seen in the table below, all Lutron thermostat controls can control a single HVAC zone. For example, an application with 3 HVAC zones will need 3 Lutron thermostat controls.

Maximum...	LR-HVAC-1-WH	SMC55 Controller	LR-HWLV-HVAC	L-HWLV2-WIFI
Zones per thermostat control	1	1	1	1
Radio Powr Savr temperature sensors per zone	4	n/a	n/a	n/a
Radio Powr Savr temperature sensors per RF link	5	n/a	n/a	n/a
Lutron flush mount wired sensors per zone	1	1	n/a	n/a

There is no specific limit to the number of LR-HVAC-1-WH or LR-HWLV-HVAC that can be used other than the overall limit of 95 devices per RF link.

There is a limit of 32 Palladiom thermostats per QS link even though the overall device limit is 99 devices per QS link. Each SMC55 controller requires one HomeWorks QS Palladiom thermostat. Each HomeWorks QS Palladiom thermostat counts as one device on the QS link. Up to 4 Palladiom thermostats can be used in a single zone (1 master thermostat and 3 companion thermostats).

There is a limit of 5 Radio Powr Savr temperature sensors per RF link when using LR-HVAC-1-WH. Exceeding this limit requires the addition of another RF link or the use of Lutron flush mount wired sensors for the remaining HVAC zones. Adding another RF link may increase the cost of the system if another main repeater (RadioRA 2) or processor (HomeWorks QS) needs to be added to the system.

Some multi-zone systems use a non-Lutron zone/damper controller to manage multiple zones throughout the house. Lutron thermostat controls are compatible with these zone/damper controllers, often through a 3rd party interface.

Features Desired By the End User

Another consideration when choosing a Lutron thermostat control is to understand what HVAC control and features the customer desires/requires. The table below includes key product features of Lutron thermostat controls.

Feature		LR-HVAC-1-WH	SMC55 Controller ¹	LR-HWLV-HVAC	L-HWLV2-WIFI
Aesthetic	Traditional thermostat look/feel	No	No	Yes	Yes
	Minimal space/ visual impact	Yes	Yes	No	No
Function	7 day scheduling	Yes	Yes	Yes	Yes ²
	Temperature averaging	Yes	No	No	No
	Remote temperature sensing	Yes	Yes	Yes	Yes
	Outdoor temperature sensing	No	No	Yes	Yes
	3rd party integration	Yes	Yes	Yes	No
	Lutron Connect app	Yes	Yes	Yes	Yes
	Requires Lutron Connect bridge	No	No	No	Yes
	RadioRA 2 programmable	Yes	No	Yes	No
	HomeWorks QS programmable	Yes	Yes ³	Yes	No
	Humidity sensing	No	No	No	Yes
	Humidification/ dehumidification	No	No	No	Yes
	Ventilation control	No	No	No	Yes
Device interoperability	HomeWorks QS Palladiom thermostat	No	Yes	No	No
	seeTemp wall display	Yes	No	Yes	No
	Radio Powr Savr temperature sensor	Yes	No	No	No
	Keypad or occupancy/vacancy sensor control	Yes	Yes	Yes	No
	QS link	No	Yes	No	No
	RF link	Yes	No	Yes	No
	Wi-Fi	No	No	No	Yes
System	RadioRA 2	Yes	No	Yes	Yes
	HomeWorks QS	Yes	Yes	Yes	Yes

¹ For use with a HomeWorks QS Palladiom thermostat.

² Scheduled defined on the thermostat, not in the programming software.

³ Requires HomeWorks QS software version 11.0 and newer.

Glossary of Key Terms

Air Conditioner

A system using refrigerant to cool the air in the living space. The refrigerant gets evaporated within a coil inside the house. Hot air from the space passes over this coil and the refrigerant absorbs the heat and is piped to a condenser unit which is typically outside the house. The heat is released outside and the refrigerant is recycled and sent back into the house for further heat extraction.

Air Handler

A device which takes the cooled or heated air and moves it throughout the building via the duct work.

Auxiliary Heat

Heat pump systems can be run in reverse to provide heat but the heat provided may not have enough BTUs to heat the residence during the coldest days of the year in certain geographical areas. Heat pumps are often supplemented by another heat source, an auxiliary heat source, which is commonly electric. As the temperature falls, even with the heat mode of the heat pump triggered, the auxiliary heat is also triggered to adequately heat the living space. Both the heat pump and the auxiliary heat are working at the same time.

Changeover/Reversing Valve

The connection utilized to switch a heat pump system from heat to cool mode, reversing the flow of refrigerant in the system. The connection is either designated with an “O” for cool or “B” for heat.

Emergency Heat or Auxiliary Only Mode

This is a feature found in heat pump systems. It is used when the heat pump equipment is inoperative. It can be manually triggered to turn on a supplemental heat source, typically electric, to provide heat for the house until the heat pump is operating again. This is different from auxiliary heat in that only one heating method is running at a time.

Furnace

A device which generates heat for the living space and distributes the heat via air or water. Some systems utilize electric elements which become hot as current passes through them. Hot air is then passed over the elements, transferring the heat to the air, and distributed to the rest of the house. Other systems utilize fossil fuels which are combusted and are used to heat water or heat air in a heat exchanger and the air or water is then distributed throughout the living space.

Geothermal or Ground Source Heat Pump

A system which utilizes the Earth as a source of heat (for heating) or as a heat sink (for cooling). This type of system is often referred to as a ground source heat pump because geothermal often implies the harvesting of heat from the Earth which is not the case. These heat pumps harvest the energy from the sun that is absorbed by the surface of the Earth.

Heat Pump

A system which uses a refrigerant to both cool and heat the air in the living space. In cool mode, the refrigerant gets evaporated within a coil that is inside the house. Hot air from the space passes over this coil and the refrigerant absorbs the heat and is piped to a condenser which is outside of the house. The heat is released outside and the refrigerant is recycled and sent back into the house for further heat extraction.

In heat mode, the process is run in reverse. Refrigerant gets evaporated outside of the house. Hot air passes over the outside unit and the refrigerant absorbs the heat and is piped to a condenser unit which is inside of the house. The heat is released inside and the refrigerant is recycled and sent back outside of the house for further heat absorption.

The switching between modes is performed using the changeover/reversing valve connection.

Glossary of Key Terms (continued)

Line Voltage Baseboard Heat

A system in which a special line voltage capable thermostat switches a baseboard electric heating element on or off based on the current room temperature and set point.

Millivolt Heat Only

A heating system usually implementing gas fired wall or floor heaters to heat the space. The system requires 2 wires for the special millivolt capable thermostat or a standard/non-electric heat-only thermostat. It has no connection to any sort of AC power source. The small electrical voltage is produced by using the flame from the pilot light.

Packaged Units

Usually an outdoor installed air handler which has built-in heating or cooling elements. These elements generate the warm or cool air and air is moved into the space via the duct work.

Split System Air Conditioner

An air conditioning system which has two to five pieces including an outdoor mounted condenser and interior evaporator units. A separate piece, called the air handler, moves the air through the space via the duct work.

Stage

A level of operation for a piece of HVAC equipment. A stage can be for cooling or heating. Single stage means that there is one level of output when performing the cooling or heating stage. To improve efficiency, multi-stage systems use low and high levels as separate stages. When it is desirable to reach the desired temperature faster, a higher level or second stage will be triggered and efficiency will be lost compared to using the lower level or first stage.

Temperature Averaging

A process by which a thermostat can receive multiple temperature readings from various temperature sensors within a specific space or zone. The thermostat averages the temperature readings which allows for a more even temperature in the zone. This provides balance by helping to prevent one room from being hotter than another room in the same zone.

Zone

To improve the efficiency of a system, the entire home is often split into smaller segments called zones. Zones are separate areas of the house which are managed by the same thermostat. When a zone requires heating or cooling, that part of the system can turn on without running the entire system for the rest of the house. Some systems may have one zone per floor and others may have one zone per room.

Frequently Asked Questions (FAQs)

Does L-HWLV2-WIFI utilize Clear Connect technology to communicate with a RadioRA 2 or HomeWorks QS system?

No, L-HWLV2-WIFI does not have Clear Connect technology. Instead, it utilizes a wireless network connection to communicate to the Lutron system. The thermostat uses a Total Connect Comfort account with Honeywell to establish a cloud to cloud connection with the Lutron Connect bridge installed in the residence, allowing control via the Lutron Connect mobile application.

Does L-HWLV2-WIFI require a Lutron Connect bridge in order to work a RadioRA 2 or HomeWorks QS system?

Yes, L-HWLV2-WIFI does require a Lutron Connect bridge. It also requires the Lutron Connect mobile application and a Honeywell Total Connect Comfort account.

Is it possible for a RadioRA 2 or HomeWorks QS system to operate with other Honeywell Wi-Fi thermostats via a Total Connect Comfort account?

Yes, it is possible for other Honeywell Wi-Fi thermostats to integrate with RadioRA 2 or HomeWorks QS systems using the cloud to cloud integration of the Honeywell Total Connect Comfort account along with the Lutron Connect bridge and Lutron Connect mobile application. Currently, only the Honeywell Lyric Wi-Fi thermostat is not compatible.

Does the Nest Learning Thermostat integrate with RadioRA 2 or HomeWorks QS systems?

Yes, the Nest Learning Thermostat does integrate with the RadioRA 2 and HomeWorks QS systems. Integration requires a Lutron Connect bridge, Lutron Connect mobile application, and a Nest account.

Can one of the Lutron thermostats control a VRV/VRF system?

Yes. LR-HWLV-HVAC, LR-HVAC-1-WH, Palladiom thermostats, and SMC55 controller can control some LG and Mitsubishi VRF systems via LG and Mitsubishi interfaces. HomeWorks QS systems also include built-in support of CoolAutomation equipment. This is an interface that allows for control of the VRV/VRF system from HomeWorks QS controls and system triggers (e.g., HomeWorks QS Palladiom thermostat). HomeWorks QS systems can also integrate with this equipment via the Commander interface by North Building Technologies.

Appendix A - L-HWLV2-WIFI Diagram

↔ Ethernet (wired LAN)

↔ Wi-Fi

↔ Mobile WAN

↔ WAN

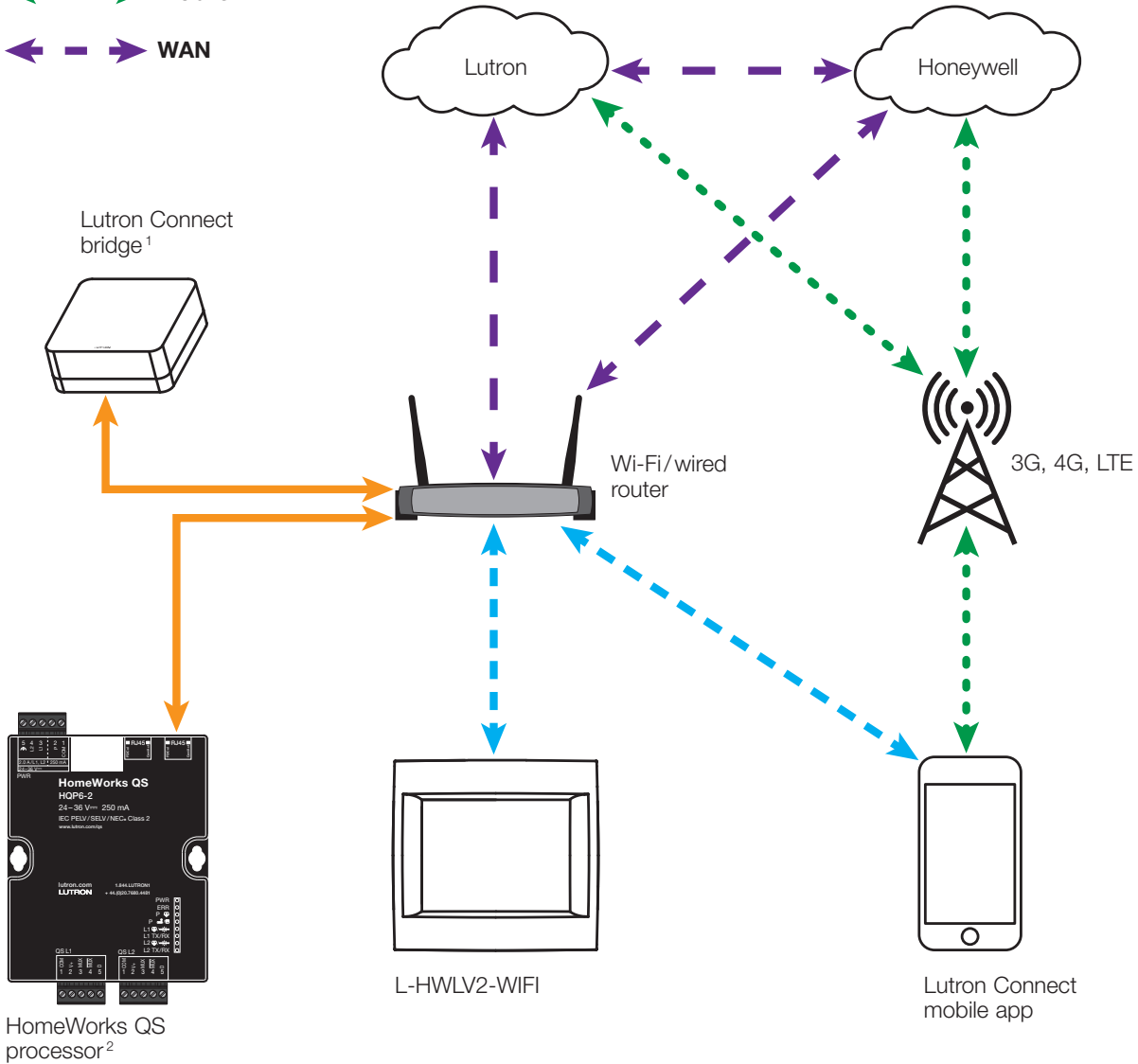

¹ Only one Lutron Connect bridge required per system (not one per processor).

² Can be substituted by a RadioRA 2 main repeater for RadioRA 2 systems.

Appendix B - Nest Learning Thermostat Diagram

↔ Ethernet (wired LAN)

↔ Wi-Fi

↔ Mobile WAN

↔ WAN

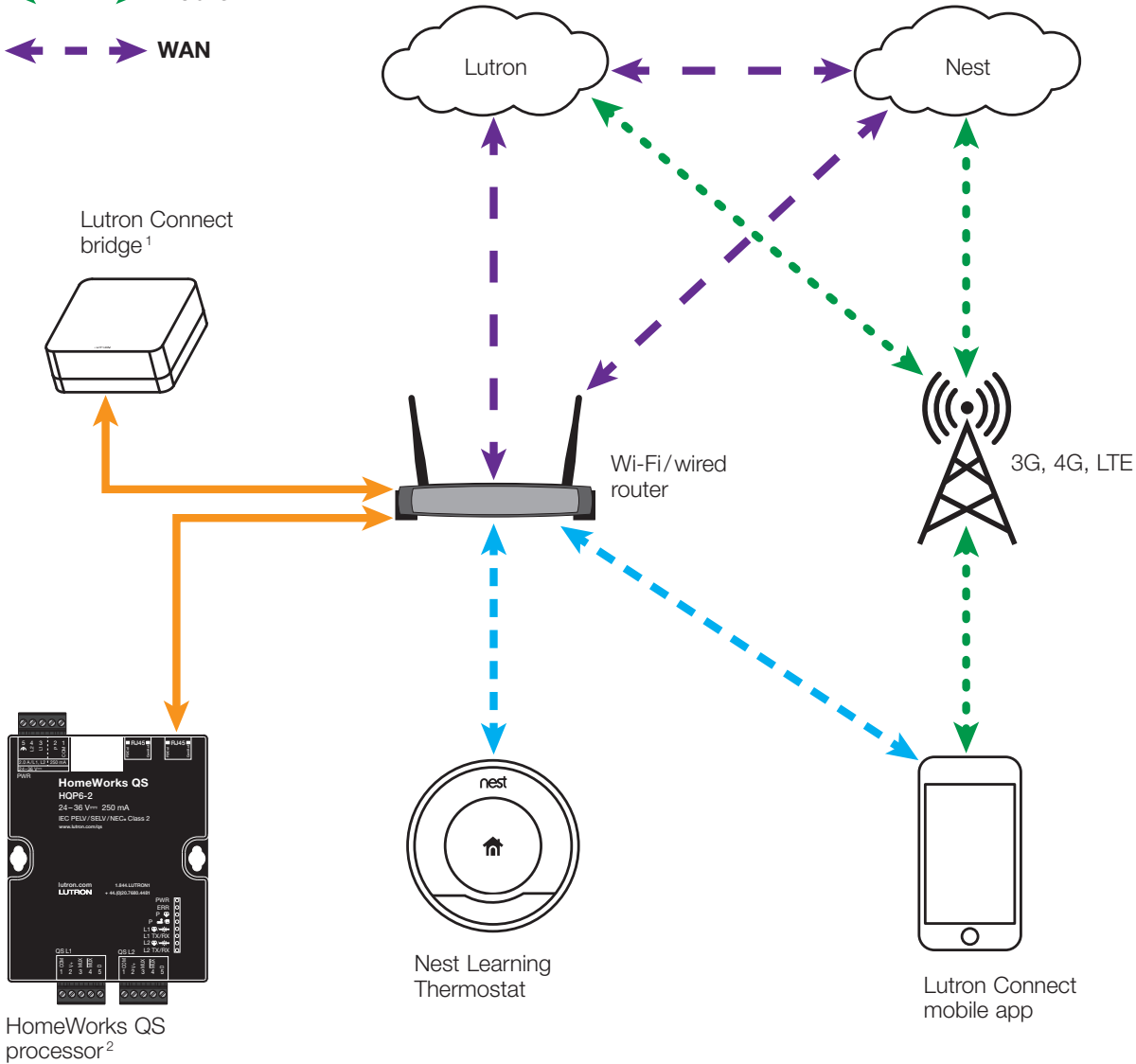

¹ Only one Lutron Connect bridge required per system (not one per processor).

² Can be substituted by a RadioRA 2 main repeater for RadioRA 2 systems.

Appendix C - HomeWorks QS Palladiom Thermostat Diagram

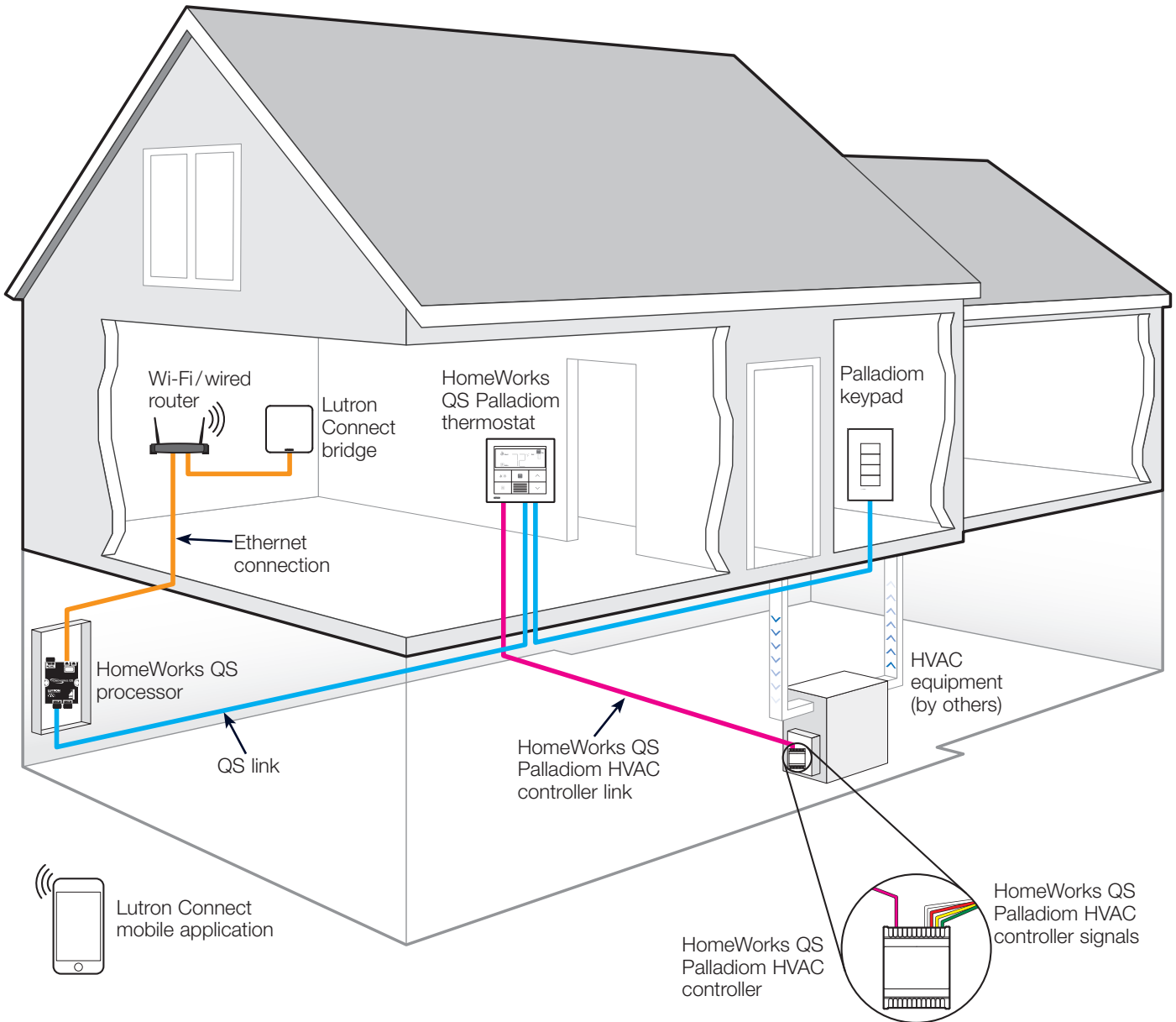

Appendix D - Common Heating Systems in the U.S.A.

Based on 2010 data

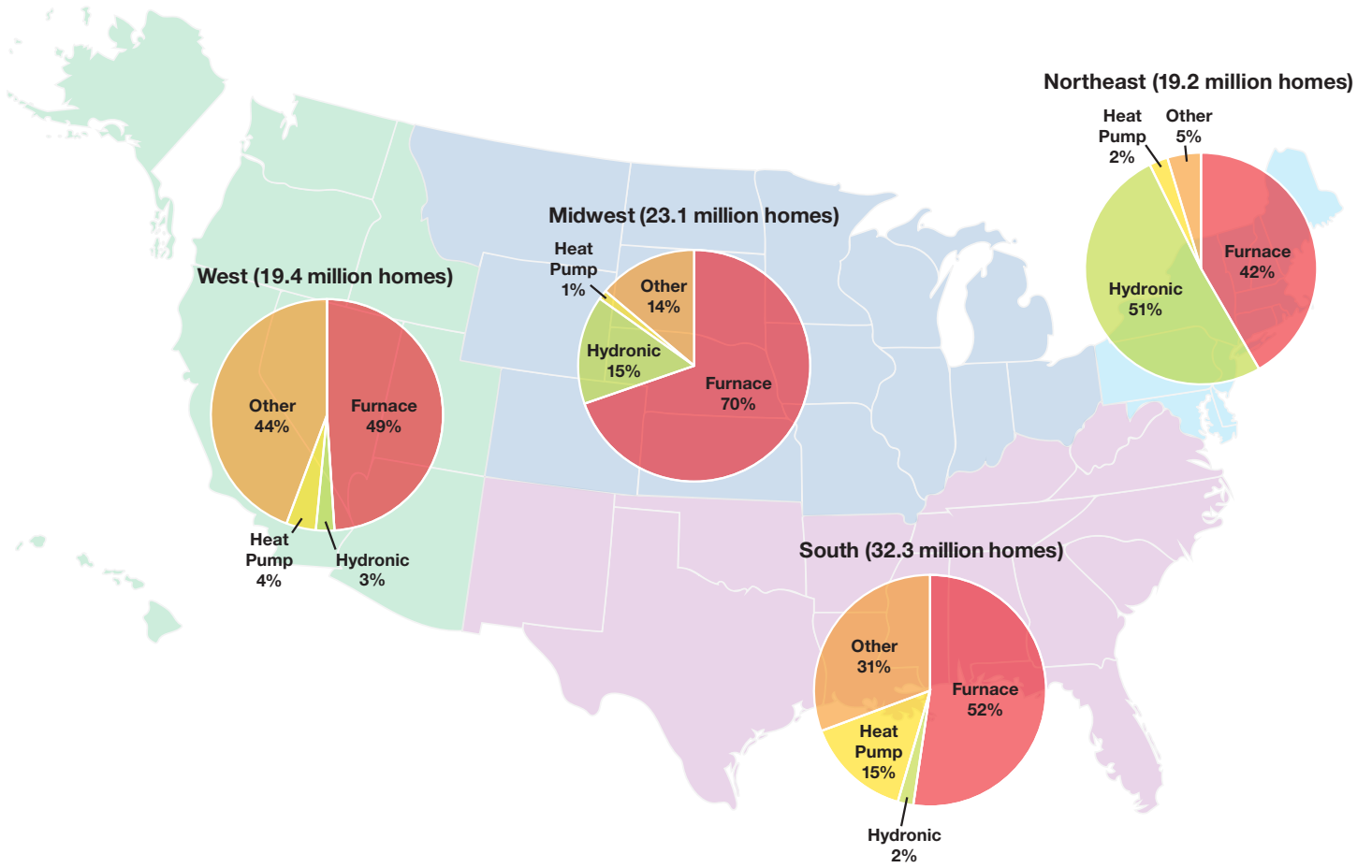

Lutron, HomeWorks, RadioRA, TouchPRO Wireless, seeTemp, Clear Connect, Lutron Connect, RadioRA 2, Radio Powr Savr, and Palladiom are trademarks or registered trademarks of Lutron Electronics Co., Inc. in the US and/or other countries.

Honeywell is a trademark of Honeywell International Inc.

Nest and Nest Learning Thermostat are trademarks licensed by Nest Labs, Inc.

Lutron Contact Numbers

WORLD HEADQUARTERS

USA
Lutron Electronics Co., Inc.
7200 Suter Road
Coopersburg, PA 18036-1299
TEL: +1.610.282.3800
FAX: +1.610.282.1243
support@lutron.com
www.lutron.com/support

North & South America

Customer Assistance
USA, Canada, Caribbean:
1.844.LUTRON1 (1.844.588.7661)
Mexico:
+1.888.235.2910
Central/South America:
+1.610.282.6701

EUROPEAN HEADQUARTERS

United Kingdom
Lutron EA Ltd.
6 Sovereign Close
London, E1W 3JF United Kingdom
TEL: +44.(0)20.7702.0657
FAX: +44.(0)20.7480.6899
FREEPHONE (UK): 0800.282.107
Technical Support: +44.(0)20.7680.4481
lutronlondon@lutron.com

ASIAN HEADQUARTERS

Singapore
Lutron GL Ltd.
390 Havelock Road
#07-04 King's Centre
Singapore 169662
TEL: +65.6220.4666
FAX: +65.6220.4333
Technical Support: 800.120.4491
lutronsea@lutron.com

Asia Technical Hotlines

Northern China: 10.800.712.1536
Southern China: 10.800.120.1536
Hong Kong: 800.901.849
Indonesia: 001.803.011.3994
Japan: +81.3.5575.8411
Macau: 0800.401
Taiwan: 00.801.137.737
Thailand: 001.800.120.665853
Other Countries: +65.6220.4666