

How to Retrofit a Wall-Mounted RF seeTouch® Keypad Into an Existing Home

Option #1: Replace a 3-way Switch

SCHEME A

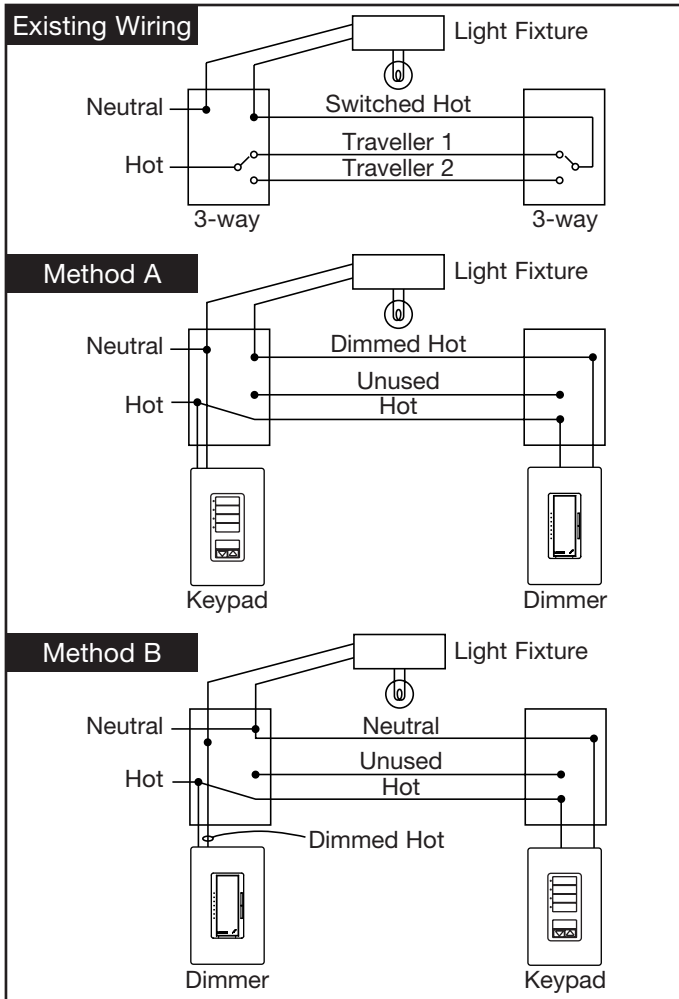

SCHEME B

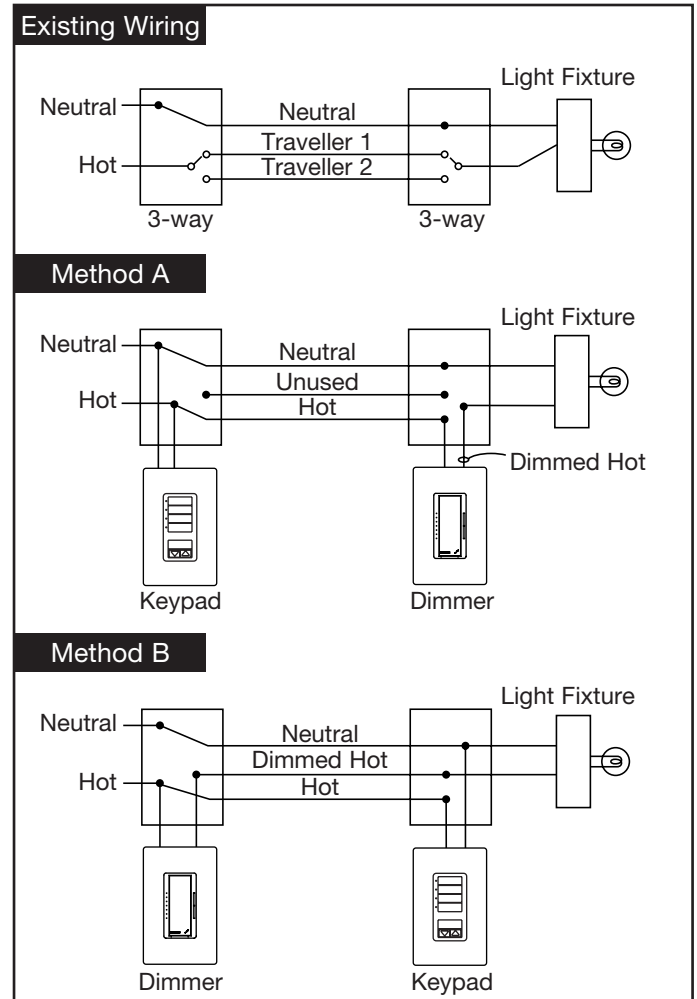

SCHEME C (DO NOT ATTEMPT)

NOTE: This is an example of a wiring scheme that WILL NOT WORK when retrofitting a keypad.

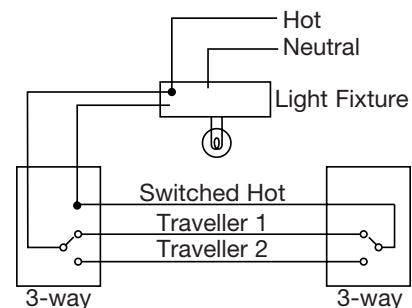

Option #2: Add a New Box Over an Existing Box

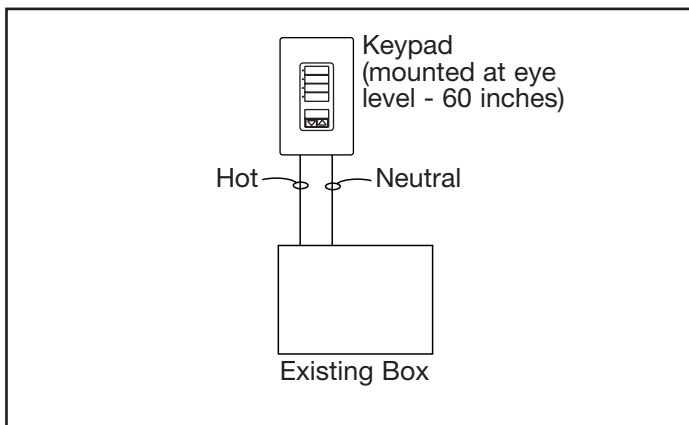

Option #3: Add a Gang to an Existing Box

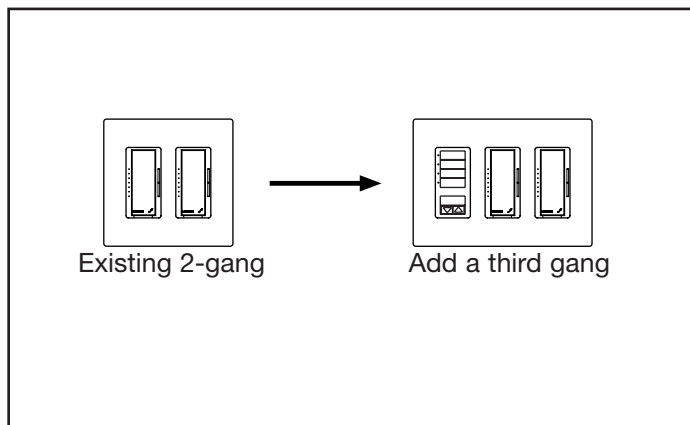

Option #4: Add a New Box Over an Existing Receptacle

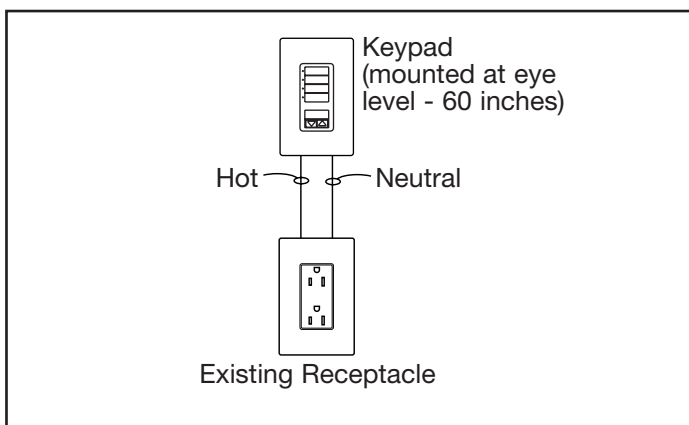

Lutron Contact Numbers

USA, Canada, Caribbean

TEL: +1.610.282.3800
FAX: +1.610.282.1243
Technical Support:
1.800.523.9466
Toll-free:
1.888.LUTRON1
intsales@lutron.com

Mexico

+1.888.235.2910

Central/South America

+1.610.282.6701

Brazil

TEL: +55.11.3885.5152
FAX: +55.11.3887.7138
brasilsales@lutron.com

Trademarks

Lutron, seeTouch, and the Lutron logo are registered trademarks of Lutron Electronics Co., Inc.