



- Convert Modbus RTU to Modbus TCP
- Supports multiple Modbus masters
- Serial IP port redirection software to support PC applications statistics and built-in 'sniffer' for troubleshooting

Cyber Security Features

- Multi-level user passwords
- SSH/SSL (128-bit encryption)
- Enable/disable ports, MAC based port security
- Port based network access control (802.1x)
- VLAN (802.1Q) to segregate and secure network traffic
- RADIUS centralized password management
- SNMPv3 authentication and 56-bit encryption

Ethernet Ports

- Integrated Ethernet Switch – up to 4 ports
- High performance and throughput Ethernet switching
- Fully IEEE 802.3, IEEE 802.3u, IEEE 802.3x compliance
- Non-blocking, store and forward switching
- 10/100BaseTX, 10BaseFL, 100BaseFX options

Remote Dial Up Access

- Integrated V.90 modem and PPP server
- Provides remote access to serial devices and Ethernet LAN

RuggedRated™ for Reliability in Harsh Environments

- Immunity to EMI and heavy electrical surges
 - Meets IEEE 1613 (electric utility substations)
 - Exceeds IEC 61850-3 (electric utility substations)
 - Exceeds IEC 61800-3 (variable speed drive systems)
 - Exceeds IEC 61000-6-2 (generic industrial)
 - Exceeds NEMA TS-2 (traffic control equipment)
- Fully independent 2kV (RMS) isolated serial ports
- -40°C to +85°C operating temperature (no fans)
- 18 AWG galvanized steel enclosure

Universal Power Supply Options

- Fully integrated power supplies (no external adaptors)
- Popular low voltage ranges: 24VDC(10-36VDC), 48VDC (36-59VDC)
- Universal high-voltage range: 88-300VDC or 85-264VAC
- CSA/UL 60950 safety approved to +85°C

Rugged Operating System (ROS®) Features

- Simple plug and play operation - automatic learning, negotiation, and crossover detection
- Integrated Cyber Security features
- Fast network fault recovery (<5ms) with eRSTP™
- Quality of Service (802.1p) for real-time traffic
- VLAN (802.1Q) and GVRP support
- Port Rate Limiting and Broadcast Storm Limiting
- Port configuration, status, statistics, mirroring

Management Tools

- Web-based, Telnet, CLI management interfaces
- SNMP v1/v2/v3 (56-bit encryption)
- Remote Monitoring (RMON)
- Rich set of diagnostics with logging and alarms

The RuggedServer™ RS401 is an industrially hardened, serial device server with an integrated, fully managed Ethernet switch, designed to operate reliably in electrically harsh and climatically demanding environments. Based on the popular RuggedServer™ RS400, the RS401 includes all the same functionality including an integrated 4 port serial server, 4 port managed Ethernet switch, and optional V.90 modem. In addition, the RS401 features a more compact design that is particularly suited for panel mount locations or installations with tight space restrictions. The RS401 is an ideal device to connect and "IP-enable" legacy serial devices or IEDs for Ethernet network connectivity.

The RS401 provides a high level of immunity to electromagnetic interference and heavy electrical surges typical of environments found in electric utility substations, factory floors or in curb side traffic control cabinets. The RS401 meets or exceeds a wide range of industry standards including IEC61850, IEEE1613, IEC61000-6-2, IEC61800-3, and NEMA TS-2. The RS401 also features a wide operating temperature range of -40°C to +85°C allowing it to be installed in virtually any location.

The RS401 also includes an industrially rated integrated power supply that can support a wide range of power supply options suitable for multiple industries and for worldwide operability. Options include 24VDC, 48VDC, and 88VDC - 300VDC/85VAC - 264VAC, allowing for great installation flexibility.

The embedded Rugged Operating System (ROS®) within the RS401 provides advanced layer 2 and layer 3 networking functions, advanced cyber security features, and a full array of intelligent functionality for high network availability and manageability. Coupled with the ruggedized hardware design, the RS401 is ideal for creating mission-critical, real-time, control applications in any harsh environment.

The RS401 is backed by RuggedCom's all inclusive five year warranty and unsurpassed technical support.

Features and Benefits

Serial Device Server

- Fully compliant EIA/TIA RS485, RS422, RS232 serial ports (software selectable) - DB9, RJ45, Phoenix style connectors
- Transmit serial data over an IP network
- Support for Modbus TCP, DNP 3, TIN serial protocols
- Baud rates up to 230 kbps
- Point-to-point and multi-point modes

RuggedServer™ RS401

Fail-safe Output Relay

- ▶ 0.4A @ 120VAC
- ▶ 2A @ 30VDC



Integrated V.90 Modem

- ▶ 56 kbps

Integrated Power Supply

- ▶ Universal high-voltage range: 88-300VDC or 85 - 264VAC
- ▶ Popular low voltage DC ranges: 24VDC (10-36VDC) 48VDC (36-59VDC)

Mounting Options

- ▶ Panel or DIN Rail



Ethernet Ports

- ▶ 4-Port Ethernet Switch
- ▶ Fiber & Copper Ports

Serial Ports

- ▶ 4 - RS232/RS422/RS485
- ▶ DB9, RJ45, or screw terminal connectors
- ▶ 2kV Isolation per Port

Ethernet Switch Management Features



Serial IP Encapsulation

Many 'legacy' devices (RTU, PLC, IED, etc.) only support serial communications via RS232 or RS485. ROS® encapsulates the serial data within a TCP connection allowing these devices to be reached via an IP network. A wide range of baud rates, frame packetization options, and diagnostics allows any serial protocol to function. The RS401 has specific support for the following serial protocols:

- Raw Socket serial encapsulation
- Modbus TCP (client and server)
- DNP 3
- WIN and TIN
- Microlok

MODBUS TCP

The Modbus protocol is ubiquitous in the industrial control and automation world. ROS® converts Modbus RTU master/slave serial data packets to Modbus TCP client/server packets for transmission over an IP network. This allows communications to Modbus RTU slaves via Ethernet and allows multiple masters to poll the same slave device.

Remote Dial-Up Access

A V.90 modem coupled with the PPP (Point to Point Protocol) allows ROS® to provide dial-up access via POTS (plain old telephone system) providing connectivity to serial devices and Ethernet LAN. PAP/CHAP authentication provide security against unauthorized access.

Enhanced Rapid Spanning Tree Protocol (eRSTP™)

RuggedCom eRSTP™ allows the creation of fault-tolerant ring and mesh Ethernet networks that incorporate redundant links that are 'pruned' to prevent loops. eRSTP™ yields worst-case fault recovery¹ of 5ms times the 'bridge diameter' and allows rings of up to 160 switches. For example, a ring of ten switches will have fault recovery times under 50ms. eRSTP™ implements both STP and RSTP to ensure interoperability with commercial switches unlike other proprietary 'ring' solutions.

Quality of Service (IEEE 802.1p)

Some networking applications such as real-time control or VoIP (voice over IP) require predictable arrival times for Ethernet frames. Switches can introduce latency in times of heavy network traffic due to the internal queues that buffer frames and then transmit on a first come first serve basis. ROS® supports 'Class of Service' in accordance with IEEE 802.1p that allows time critical traffic to jump ahead to the front of the queue thus minimizing latency and reducing jitter to allow such demanding applications to operate correctly. ROS® allows priority classification by port, tags, MAC address, and IP type of service (TOS). A configurable "weighted fair queuing" algorithm controls how frames are emptied from the queues.

VLAN (IEEE 802.1Q)

Virtual local area networks (VLAN) allow the segregation of a physical network into separate logical networks with independent broadcast domains. A measure of security is provided since hosts can only access other hosts on the same VLAN and traffic storms are isolated. ROS® supports 802.1Q tagged Ethernet frames and VLAN trunks. Port based classification allows legacy devices to be assigned to the correct VLAN.

IGMP Snooping

ROS® uses IGMP snooping (Internet Group Management Protocol v1&v2) to intelligently forward or filter multicast traffic streams (e.g. MPEG video) to or from hosts on the network. This reduces the load on network trunks and prevents packets from being received on hosts that are not involved. ROS® has a very powerful implementation of IGMP snooping that:

- Can be enabled on a per VLAN basis
- Detects and filters all multicast streams regardless of whether subscribers exist
- Supports "router-less" operation by supporting an "active" mode
- Restores traffic streams immediately after an RSTP topology change

Ethernet Port Mirroring

ROS® can be configured to duplicate all traffic on one port to a designated mirror port. When combined with a network analyzer, this can be a powerful troubleshooting tool.

Ethernet Port Configuration and Status

ROS® allows individual ports to be 'hard' configured for speed, duplex, auto-negotiation, flow control and more. This allows proper connection with devices that do not negotiate or have unusual settings. Detailed status of ports with alarm and SNMP trap on link problems aid greatly in system troubleshooting.

Ethernet Statistics and RMON

ROS® provides continuously updating statistics per port that provide both ingress and egress packet and byte counters as well as detailed error figures. Also provided is full support for the RMON statistics, history, alarms, and event groups. RMON allows for very sophisticated data collection, analysis and detection of traffic patterns.

Loss of Link Management

Some intelligent electronic devices (IEDs) have dual fiber optic ports with automatic failover to a backup port should the primary fail. ROS® ensures this mechanism works reliably under all failure modes by appropriately disabling link signals when required. ROS® also flushes learned MAC addresses to ensure the failover occurs quickly.

Ethernet Switch Management Features



Broadcast Storm Filtering

Broadcast storms wreak havoc on a network and can cause attached devices to malfunction. This could be disastrous on a network with mission critical equipment. ROS® limits this by filtering broadcast frames with a user-defined threshold.

SNMP (Simple Network Management Protocol)

SNMP provides a standardized method for network management stations the ability to interrogate devices from different vendors. SNMP versions supported by ROS® are v1, v2c, and v3. SNMPv3 in particular provides security features such as authentication, privacy with data encryption (CBC-DES with 56-bit encryption key) and access control not present in earlier SNMP versions. ROS® supports numerous standard MIBs (Management Information Base) allowing for easy integration with any network management system (NMS). A feature of SNMP supported by ROS® is the ability to generate “traps” upon system events. RuggedNMS™, the RuggedCom management solution, can record traps from multiple devices providing a powerful network troubleshooting tool. It also provides a graphical visualization of the network and is fully integrated with all RuggedCom products.

HTML Web Browser and Telnet User Interfaces

ROS® provides a simple, intuitive user interface for configuration and monitoring via a standard graphical web browser or via Telnet. All system parameters include detailed on-line help to make setup a breeze. ROS®, presents a common look and feel and standardized configuration process allowing easy migration to other RuggedCom managed products.

SNTP (Simple Network Time Protocol)

SNTP automatically synchronizes the internal clock of all ROS® devices on the network. This allows for correlation of time stamped events for troubleshooting.

Event Logging and Alarms

ROS® records all significant events to a non-volatile system log allowing forensic troubleshooting. Events include link failure and recovery, unauthorized access, broadcast storm detection, and self-test diagnostics among others. Alarms provide a snapshot of recent events that have yet to be acknowledged by the network administrator. An extreme hardware relay is de-energized during the presence of critical alarms allowing an external controller to react if desired.

Configuration via ASCII Text File

All configuration parameters are stored in an ASCII formatted text file that can easily be transferred via TFTP or Xmodem. The configuration file can be saved for backup purposes and easily manipulated by a text editor. The text same file can be downloaded to the switch at a later date in order to re-configure or restore a previous configuration.

Command Line Interface (CLI)

A command line interface can be used in conjunction with remote shell to automate data retrieval, configuration updates, and firmware upgrades. A powerful SQL-like capability allows expert users the ability to selectively retrieve or manipulate any parameters the device has to offer.

EMI and Environmental Type Tests

IEC 61850-3 EMI TYPE TESTS				
TEST	Description		Test Levels	Severity Levels
IEC 61000-4-2	ESD	Enclosure Contact	+/- 8kV	4
		Enclosure Air	+/- 15kV	4
IEC 61000-4-3	Radiated RFI	Enclosure ports	20 V/m	x
IEC 61000-4-4	Burst (Fast Transient)	Signal ports	+/- 4kV @ 2.5kHz	x
		D.C. Power ports	+/- 4kV	4
		A.C. Power ports	+/- 4kV	4
		Earth ground ports ³	+/- 4kV	4
IEC 61000-4-5	Surge	Signal ports	+/- 4kV line-to-earth, +/- 2kV line-to-line	4
		D.C. Power ports	+/- 2kV line-to-earth, +/- 1kV line-to-line	3
		A.C. Power ports	+/- 4kV line-to-earth, +/- 2kV line-to-line	4
IEC 61000-4-6	Induced (Conducted) RFI	Signal ports	10V	3
		D.C Power ports	10V	3
		A.C. Power ports	10V	3
		Earth ground ports ³	10V	3
IEC 61000-4-8	Magnetic Field	Enclosure ports	40 A/m continuous, 1000 A/m for 1 s	N/A
IEC 61000-4-29	Voltage Dips & Interrupts	D.C. Power ports	30% for 0.1s, 60% for 0.1s, 100% for 0.05s	N/A
IEC 61000-4-11		A.C. Power ports	30% for 1 period, 60% for 50 periods 100% for 5 periods, 100% for 50 periods ²	N/A
IEC 61000-4-12	Damped Oscillatory	Signal ports	2.5kV common, 1kV diff. mode@1MHz	3
		D.C. Power ports	2.5kV common, 1kV diff. mode@1MHz	3
		A.C. Power ports	2.5kV common, 1kV diff. mode@1MHz	3
IEC 61000-4-16	Mains Frequency Voltage	Signal ports	30V Continuous, 300V for 1s	4
		D.C. Power ports	30V Continuous, 300V for 1s	4
IEC 61000-4-17	Ripple on D.C. Power Supply	D.C. Power ports	10%	3
IEC 60255-5	Dielectric Strength	Signal ports	2kVac (Fail-Safe Relay output)	N/A
		D.C. Power ports	1.5kV DC	N/A
		A.C. Power ports	2kVac	N/A
IEC 60255-5	H.V. Impulse	Signal ports	5kV (Fail-Safe Relay output)	N/A
		D.C. Power ports	5kV	N/A
		A.C. Power ports	5kV	N/A

IEEE 1613 (C37.90.x) EMI IMMUNITY TYPE TESTS				
Test	Description		Test Levels	Severity Levels
IEEE C37.90.3	ESD	Enclosure Contact	+/- 8kV	N/A
		Enclosure Air	+/- 15kV	N/A
IEEE C37.90.2	Radiated RFI	Enclosure ports	35 V/m	N/A
IEEE C37.90.1	Fast Transient	Signal ports	+/- 4kV @ 2.5kHz	N/A
		D.C. Power ports	+/- 4kV	N/A
		A.C. Power ports	+/- 4kV	N/A
		Earth ground ports ³	+/- 4kV	N/A
IEEE C37.90.1	Oscillatory	Signal ports	2.5kV common mode @1MHz	N/A
		D.C. Power ports	2.5kV common, 1kV diff. mode@1MHz	N/A
		A.C. Power ports	2.5kV common, 1kV diff. mode@1MHz	N/A
IEEE C37.90	Dielectric Strength	Signal ports	2kVac	N/A
		D.C. Power ports	1.5kV DC	N/A
		A.C. Power ports	2kVac	N/A

Environmental Type Tests				
Test	Description		Test Levels	Severity Levels
IEC 60068-2-1	Cold Temperature	Test Ad	-40°C, 16 Hours	N/A
IEC 60068-2-2	Dry Heat	Test Bd	+85°C, 16 Hours	N/A
IEC 60068-2-30	Humidity (Damp Heat, Cyclic)	Test Db	95% (non-condensing), 55°C , 6 cycles	N/A
IEC 60255-21-1	Vibration	Tests Fc	2g @ (10 - 150) Hz	Class 2
IEC 60255-21-2	Shock	Tests Ea	30g @ 11mS	Class 2

Notes:
 1. Only applicable to functional earth connections separated from the safety earth connection.
 2. Class 2 refers to "Measuring relays and protection equipment for which a very high security margin is required or where the vibration levels are very high,(e.g. shipboard application and for severe transportation conditions")

Technical Specifications

Power Supply

- Power Consumption: 8W (max)
- 24VDC: 10-36VDC (max)
- 48VDC: 36-59VDC (max)
- HI Voltage AC/DC: 88-300VDC, 85-264VAC (max)

Critical Alarm Relay

- Form-C failsafe contact relay: 1A@30VDC

Physical

- Height: 3.5" (8.9cm)
- Width: 6.76" (17.2cm)
- Depth: 7.42" (18.8cm)
- Weight: 4.15lbs (1.9 Kg)
- Ingress Protection: IP40 (1mm objects)
- Enclosure: 18 AWG galvanized steel enclosure
- Mounting: DIN rail or panel mounted

Switch Properties

- Switching method: Store & Forward
- Switching latency: 5 us (100Mbps)
- Switching bandwidth: 1.2Gbps
- MAC addresses: 2048
- MAC address table size: 16kbytes
- Priority Queues: 4
- Frame buffer memory: 1-Mbit
- Simultaneous VLANs: 255
- VLAN ID Range: 1 to 4094
- IGMP multicast groups: 256

Approvals

- ISO: Designed and manufactured using a ISO9001: 2000 certified quality program
- CE Marking
- Emissions: FCC Part 15 (Class A), EN55022 (CISPR22 Class A)
- Safety: cCSAus (Compliant with CSA C22.2 No. 60950, UL 60950, EN60950)
- Laser Eye Safety (FDA/CDRH): Complies with 21 CFR Chapter1, Subchapter J.

Warranty

- 5 Years - Applicable to design or manufacturing related product defects.

Network Management

- HTTP graphical web-based, SSL (128-bit encryption)
- SNMP v1, v2c, v3 (56-bit encryption)
- Telnet, VT100, SSH/SFTP (128-bit encryption)
- Command Line Interface (CLI)
- RSA Key Management (1024 bit key)
- Authentication and Accounting - TACACS+ (encrypted), RADIUS client, PPP

EMI Immunity and Environmental Compliance

- IEC 61000-6-2 Industrial (Generic)
- IEC 61800-3 Industrial (Variable Speed Drive Systems)
- IEC 61850-3 Electric Utility Substations
- IEEE 1613 Electric Utility Substations
- NEMA TS 2 Traffic Control Equipment

IEEE Compliance

- 802.3-10BaseT
- 802.3u-100BaseTX, 100BaseFX
- 802.3x-Flow Control
- 802.3D-MAC Bridges
- 802.1D-Spanning Tree Protocol
- 802.1p-Class of Service
- 802.1Q-VLAN Tagging
- 802.1w-Rapid Spanning Tree Protocol

IETF RFC Compliance

- RFC791-IP
- RFC792-ICMP
- RFC793-TCP
- RFC783-TFTP
- RFC826-ARP
- RFC768-UDP
- RFC894-IP over Ethernet
- RFC854-Telnet
- RFC1519-CIDR
- RFC1541-DHCP (client)
- RFC1112-IGMP v1
- RFC 1661-PPP
- RFC2236-IGMP v2
- RFC2030-SNTP
- RFC2068-HTTP

IETF SNMP MIBS

- RFC1493-BRIDGE-MIB
- RFC1907-SNMPv2-MIB
- RFC2012-TCP-MIB
- RFC2013-UDP-MIB
- RFC2578-SNMPv2-SMI
- RFC2579-SNMPv2-TC
- RFC2819-RMON-MIB
- RFC2863-IF-MIB
- draft-ietf-bridge-rstpmb-03-BRIDGE-MIB
- draft-ietf-bridge-bridgemib-smiv2-03-RSTP-MIB
- IANAifType-MIB

Fiber Optical Specifications					
Parameter	Fiber Port Type				
	10BaseFL		100BaseFX		
Mode	Multimode	Multimode	Singlemode		
Connectors	ST	MTRJ / ST / SC	LC / SC		
Typical Dist. (km)	2	2	20	50	90
Optical Wavelength (nm)	820	1310	1310		
Cable Size Core/Cladding (um)	50 or 62.5/125	50 or 62.5/125	8 or 9/125		
Tx Power (dBm)	-34.4	-15.7	-15.5	-2.5	2.5
Rx Sensitivity (dBm)	-8.2	-33.5	-32	-37	-39
Typical Budget	22	17	16.5	34.5	41.5

Longer segment lengths dependent on fiber specifications. Consult factory for further details.

Mechanical Drawings

FRONT DIN/PANEL MOUNT
(OPTION D)

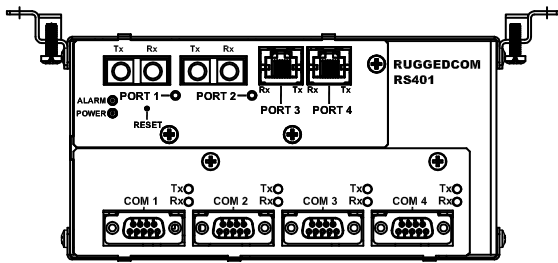

TOP VIEW

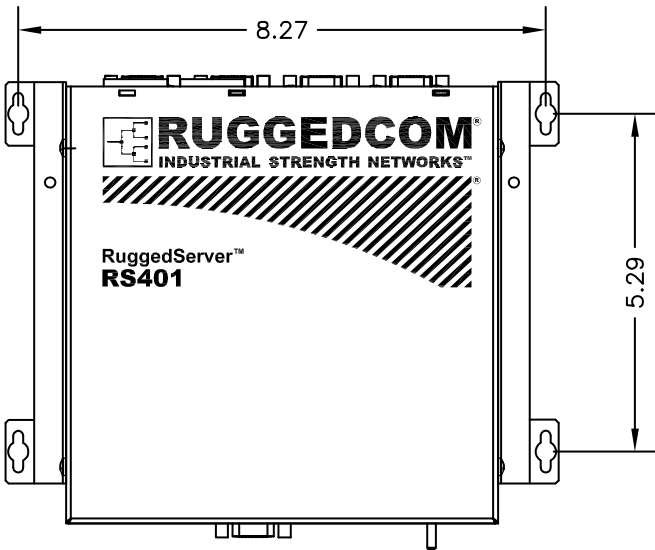

FRONT VIEW

SIDE DIN/PANEL MOUNT
(OPTION P)

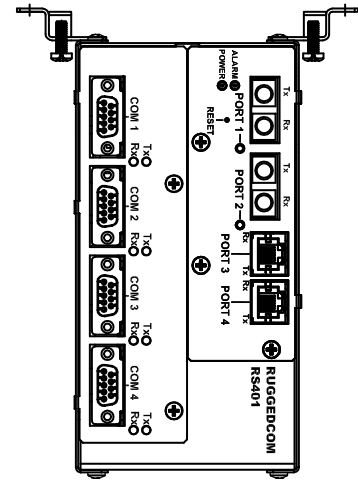

TOP VIEW

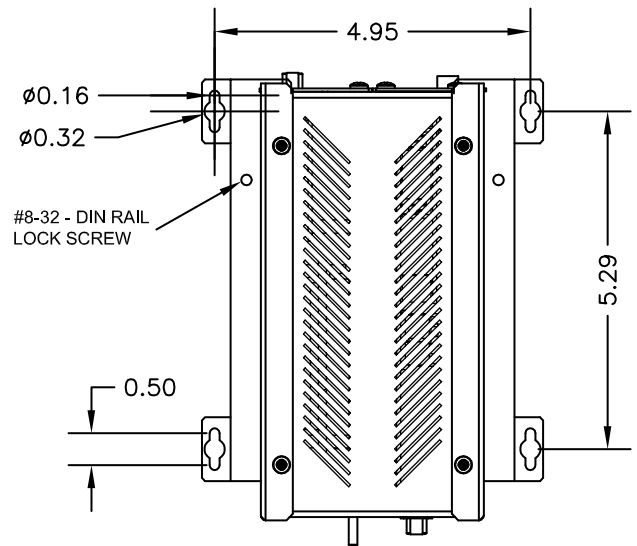

FRONT VIEW

Order Codes

RS401 - - - - - -
 PS M E1E2 SP MP MOD

PS: Power Supply

- 24 = 24VDC (10-36 VDC)
- 48 = 48VDC (36-59 VDC)
- HI = 85-264VAC or 88-300VDC

M: mounting options

- N = no Mounting Hardware
- D = Front panel mount with DIN screw points
- P = Side panel mount with DIN screw points

E1, E2: Ethernet Ports 1 & 2 Options ⁽¹⁾

- TX = 10/100BaseTX RJ45
- FL = 10FL Multimode ST, 820nm, 2km
- MJ = 100FX Multimode MTRJ
- MC = 100FX Multimode SC
- MT = 100FX Multimode ST
- T2 = 100FX Singlemode ST, Standard 20km
- L2 = 100FX Singlemode LC, Standard 20km
- L5 = 100FX Singlemode LC, Intermediate Reach 50km
- L9 = 100FX Singlemode LC, Long Reach 90km
- C2 = 100FX Singlemode SC, Standard 20km
- C5 = 100FX Singlemode SC, Intermediate Reach 50km
- C9 = 100FX Singlemode SC, Long Reach 90km

SP Serial Port Options

- 2 = 4 x RS232 via DB9
- 4 = 4 x RS485 via 3 POS screw terminals.
- 3D = 4 x RS232/RS422/RS485 via DB9
- 3R = 4 x RS232/RS422/RS485 via RJ45

MP Modem Port Options

- Blank = No Modem
- M = V.90 (56Kbps) Modem
- ORDER CODE EXAMPLES
- RS401-24-D-TXTX-2
- RS401-48-P-FLFL-4
- RS401-HI-P-MCC2-2
- RS401-HI-N-L2L5-4-M

MOD: Manufacturing Modifications

- XX = None
- C01 = Conformal Coating

1. Ports 1 & 2 must have the same type of connector ie. RJ45, MTRJ, ST, SC, LCW.
Note: All units come standard with 2 10/100Tx RJ45 Ethernet ports (on Ports 3 & 4)

Example Order Codes:

RS401-24-D-TXTX-2-XX

24VDC Power Supply, DIN Rail Mount, 2 10/100 TX Ports,
4 x RS232 via DB9

RS401-48-P-FLFL-4-XX

48VDC Power Supply, Panel Mount, 2 10FL MM, 820nm,
2km Ports, 4 x RS485 via 3 POS screw terminals

RS401-HI-MCC2-2-C01

HI Power Supply, 1 100FX MM, SC Port, 1 100FX SM,
20km SC Port, 4 x RS232 via DB9, conformal coating

RS401-HI-N-L2L5-4-M-C01

HI Power Supply, 1 100FX SM, 20km LC Port, 1 100FX SM,
50km LC Port, 4 x RS485 via 3 POS screw terminals,
V.90 Modem, conformal coating

RuggedCom Inc.

300 Applewood Crescent, Unit 1,
Concord, Ontario, Canada L4K 5C7

Tel: +1 (905) 856-5288 **Fax:** +1 (905) 856-1995
Toll Free: 1 (888) 264-0006

Technical Support Center

Toll Free (USA & Canada): 1 (866) 922-7975
International: +1 (905) 856-5288
E-mail: Support@RuggedCom.com

© 2010 RuggedCom Inc.
RuggedSwitch is a registered trademark of RuggedCom Inc.
Ethernet is a trademark of the Xerox Corporation.
Patent Pending
All specifications in this document are subject to change without notice.
Rev 1n — 04/27/10

For additional information on our products and services, please
visit our web site at: www.RuggedCom.com