



The RuggedBackbone™ RX1510 series is a cost efficient utility grade layer 2 and layer 3 switch and router. The RX1511 and RX1512 provide a powerful and modular routing/switching platform in a compact form factor which makes them ideal for pole mount applications or installation into tight cabinets.

The RX1510 series has a modular and field replaceable platform which allows customers to select WAN, serial and Ethernet options making it ideally suited for electric power utilities, the industrial plant floor, and traffic control systems.

The RX1510 series meets the RuggedRated™ specification which provides a high level of immunity to electromagnetic interference (EMI) and heavy electrical surges typical of the harsh environments found in many industrial applications. An operating temperature range of -40 to +85°C (-40 to +185°F) allows the RX1510 series to be placed in any location.

Key Features and Benefits

Security Appliance Functions

- Multi-level passwords
- SSH/SSL encryption
- Enable/disable ports, MAC based port security
- Port based network access control (802.1x)
- VLAN (802.1Q) to segregate and secure network traffic
- RADIUS centralized password management
- SNMPv3 encrypted authentication and access security

RuggedRated™ for Reliability in Harsh Environments

- Immunity to EMI and high voltage electrical transients
 - Meets IEEE 1613 (electric utility substations)
 - Exceeds IEC 61850-3 (electric utility substations)
 - Exceeds IEC 61800-3 (variable speed drive systems)
 - Exceeds IEC 61000-6-2 (generic industrial environment)
 - Exceeds NEMA TS-2 (traffic control equipment)
- -40°C to +85°C operating temperature (no fans)
- Failsafe Output Relay: For critical failure or error alarming

Physical Ports

- Field replaceable line modules
- Up to 24-ports 100FX (RX1510)
- Up to 24-ports 10/100TX (RX1510)
- Up to 8-ports Gigabit Ethernet (RX1510)

WAN Port Options:

- T1/E1 (channelized)
- E1 75 Ohms via BNC
- Cellular (HSPA/EVDO)*
- DDS

Serial Ports:

- Fully compliant EIA/TIA RS485/RS422/RS232 serial ports (software selectable) – RJ45 connectors
- DNP, MODBUS
- Raw socket mode support allows encapsulation of any serial protocol

Protocols

- WAN
 - Frame Relay RFC 1490 or RFC 1294
 - PPP RFC 1661, 1332, 1321, 1334, PAP, CHAP Authentication
 - Multilink PPP RFC 1990
 - GOOSE messaging support
- IP
 - Routing: OSPF, BGP, RIPv1 and 2
 - VRRPv2 and VRRPv3
 - Traffic control, NTP Server, IP Multicast Routing
 - L2TPv2 and L2TPv3
 - DHCP Agent (Option 82 Capable)
 - PIM-SM

Advanced Services

- MPLS Static Label Support
- MPLS Label Distribution Protocol (LDP)

Frame Relay Support

- ISO and ITU compliant, network certified
- ANSI T1.617 Annex D, Q.933 or LMI Local Signaling

Management Tools

- Web-based, SSH, CLI management interfaces
- SNMP v1/v2/v3
- NETCONF
- Remote Syslog
- Rich set of diagnostics with logging and alarms
- Loopback diagnostic tests
- Raw and interpreted real time line traces

Universal Power Supply Options RX1510 and RX1511

- Modular
- Hot-Swappable (RX1510 only)
- Fully integrated power supplies (no external adaptors)
- Input voltage range of 10–72VDC, 88–300VDC, and 85-264VAC for worldwide operability
- CSA/UL 60950 safety approved to +85°C

Built-in Power Supply RX1512

- Input voltage range of 11-72V DC
- Fully integrated power supply (no external adaptors)



RuggedBackbone™ RX1510

RX1510



Multiple Ethernet Ports

- ▶ Up to 24 10/100BaseTx,
- ▶ Up to 8 Gigabit Ports
- ▶ Up to 24 100BaseFx Ports
- ▶ Up to 12 ports 10FL / 100SX
- ▶ SC, ST, LC and MTRJ
- ▶ Pluggable Optics (SFP)

Power Supplies

- ▶ 24VDC (15 -36 VDC)
48VDC (36-72 VDC) or
HI (88 – 300VDC/85 – 264 VAC)
- ▶ Redundant load sharing power supplies

Enclosure

- ▶ IP40
- ▶ Aluminum

Operating Temperature

- ▶ -40°C to +85°C
- ▶ No Fans

Serial Ports

- ▶ Up to 24 RS232/422/485

WAN Ports

- ▶ Up to 4 T1/E1 ports
- ▶ Cellular (EVDO / HSPA)*
- ▶ DDS (56K Master/Slave, 64K Slave)

Other Available Models

RX1511



- ▶ Single Modular Power Supply
- ▶ 2 Line Modules

RX1512



- ▶ Built-in 11-72V DC Power Supply
- ▶ 2 Line Modules

EMI Immunity

- ▶ Meets IEEE 1613 (electric utility substations)
- ▶ Exceeds IEC 61850-3 (electric utility substations)
- ▶ Exceeds IEC 61800-3 (variable speed drive systems)
- ▶ Exceeds IEC 61000-6-2 (generic industrial environment)
- ▶ Exceeds NEMA TS-2 (traffic control equipment)

Mounting Options

- ▶ Panel/DIN rail

* Carrier approvals may be required



ROX™II Features

ROX™II Software Features

- Simple plug and play operation – automatic learning, negotiation, and crossover detection
- Telecom Standard Command Line Interface (CLI)
- Single File Configuration ensures easy installation & Configuration control
- Automatic Rollback in the event of configuration errors (Configurable)
- NETCONF configuration interface supports powerful remote configuration and status features.
- VLAN (802.1Q)
- Port Rate and Broadcast Storm Limiting
- Port configuration, status, statistics, mirroring
- SNTP time synchronization (client and server)
- MSTP 802.1Q-2005 (formerly 802.1s)
- RSTP (802.1w) and Enhanced Rapid Spanning Tree (eRSTP™) network fault recovery (<5ms)
- Quality of Service (802.1p) for real-time traffic
- Traffic Control
- SNMP v1, v2c and v3 Support including RMON
- Stateful Firewall
- RIP v1/2
- OSPF
- BGP

Cyber Security

Cyber security is an urgent issue in many industries where advanced automation and communications networks play a crucial role in mission critical applications and where high reliability is of paramount importance. Key ROX™II features that address security issues at the local area network level include:

Passwords - Multi-level user passwords secures switch against unauthorized configuration

SSH / SSL - Extends capability of password protection to add encryption of passwords and data as they cross the network

Enable / Disable Ports - Capability to disable ports so that traffic can not pass

802.1Q VLAN - Provides the ability to logically segregate traffic between predefined ports on switches

SNMPv3 - encrypted authentication and access security

HTTPS - for secure access to the web interface

Enhanced Rapid Spanning Tree Protocol (eRSTP™)

RuggedCom eRSTP™ allows the creation of fault-tolerant ring and mesh Ethernet networks that incorporate redundant links that are 'pruned' to prevent loops. eRSTP™ yields worst-case fault recovery¹ of 5ms times the 'bridge diameter' and allows rings of up to 160 switches. For example, a ring of ten switches will have fault recovery times under 50ms. eRSTP™ implements both STP and RSTP to ensure interoperability with commercial switches unlike other proprietary 'ring' solutions. eRSTP also provides fast and deterministic behaviour for root bridge failure.

Quality of Service (IEEE 802.1p)

Some networking applications such as real-time control or VoIP (voice over IP) require predictable arrival times for Ethernet frames. Switches can introduce latency in times of heavy network traffic due to the internal queues that buffer frames and then transmit on a first come first serve basis. ROX™II supports 'Class of Service' that allows time critical traffic to jump ahead to the front of the queue thus minimizing latency and reducing jitter to allow such demanding applications to operate correctly. ROX™II allows priority classification by port, tags, MAC address, and IP type of service (ToS). A configurable "weighted fair queuing" algorithm controls how frames are emptied from the queues.

VLAN (IEEE 802.1Q)

Virtual local area networks (VLAN) allow the segregation of a physical network into separate logical networks with independent broadcast domains. A measure of security is provided since hosts can only access other hosts on the same VLAN and traffic storms are isolated. ROX™II supports 802.1Q tagged Ethernet frames and VLAN trunks. Port based classification allows legacy devices to be assigned to the correct VLAN. GVRP support is also provided to simplify the configuration of the switches on the VLAN.

SNMP (Simple Network Management Protocol)

SNMP provides a standardized method, for network management stations, to interrogate devices from different vendors. SNMP versions supported by ROX™II are v1,v2c, and v3. SNMPv3 in particular provides security features (such as authentication, privacy, and access control) not present in earlier SNMP versions. ROX™II also supports numerous standard MIBs (Management Information Base) allowing for easy integration with any network management system (NMS).

A feature of SNMP supported by ROX™II is the ability to generate "traps" upon system events. RuggedNMS™, the RuggedCom management solution, can record traps from multiple devices providing a powerful network troubleshooting tool. It also provides a graphical visualization of the network and is fully integrated with all RuggedCom products.

NETCONF Configuration Interface

The NETCONF configuration interface will allow administrators to set device parameters and receive device updates through the use of XML based commands. This standard, supported by multiple vendors, makes it possible to greatly simplify the task of network management.

¹ eRSTP fault recovery times may be approximated as follows:
For 100 Mbps, fault recovery performance is <5ms/hop
For 1,000 Mbps, fault recovery performance is <5ms/hop + 20ms

ROX™II Features

NTP (Network Time Protocol)

NTP automatically synchronizes the internal clock of all ROX™II devices on the network. This allows for correlation of time stamped events for troubleshooting.

Port Rate Limiting

ROX™II supports configurable rate limiting per port to limit unicast and multicast traffic. This can be essential to managing precious network bandwidth for service providers. It also provides edge security for denial of service (DoS) attacks.

Broadcast Storm Filtering

Broadcast storms wreak havoc on a network and can cause attached devices to malfunction. This could be disastrous on a network with mission critical equipment. ROX™II limits this by filtering broadcast frames with a user-defined threshold.

Port Mirroring

ROX™II can be configured to duplicate all traffic on one port to a designated mirror port. When combined with a network analyzer, this can be a powerful troubleshooting tool.

Port Configuration and Status

ROX™II allows individual ports to be 'hard' configured for speed, duplex, auto-negotiation, flow control and more. This allows proper connection with devices that do not negotiate or have unusual settings. Detailed status of ports with alarm and SNMP trap on link problems aid greatly in system troubleshooting.

Port Statistics and RMON (Remote Monitoring)

ROX™II provides continuously updating statistics per port that provide both ingress and egress packet and byte counters as well as detailed error figures. Also provided is full support for the RMON statistics, history, alarms, and event groups. RMON allows for very sophisticated data collection, analysis and detection of traffic patterns.

Event Logging and Alarms

ROX™II records all significant events to a non-volatile system log allowing forensic troubleshooting. Events include link failure and recovery, unauthorized access, broadcast storm detection, and self-test diagnostics among others. Alarms provide a snapshot of recent events that have yet to be acknowledged by the network administrator. An external hardware relay is de-energized during the presence of critical alarms allowing an external controller to react if desired.

HTML Web Browser User Interface

ROX™II provides a simple, intuitive user interface for configuration and monitoring via a standard graphical web browser or via standard telcom UI. All system parameters include detailed on-line help to make setup a breeze. ROX™II presents a common look and feel and standardized configuration process allowing easy migration to other RuggedCom managed products.

Command Line Interface (CLI)

A command line interface used in conjunction with remote shell to automate data retrieval, configuration updates, and firmware upgrades. A powerful Telecom Standard style Command Line Interface (CLI) allows expert users the ability to selectively retrieve or manipulate any parameters the device has to offer.

Link Backup

Link backup provides an easily configured means of raising a backup link upon the failure of a designated main link. The main and backup links can be Ethernet, Cellular, T1/E1, or DDS. The feature can back up to multiple remote locations, managing multiple main: backup link relationships. The feature can also back up a permanent high speed WAN link to a permanent low speed WAN link and can be used to migrate the default route from the main to the backup link.

OSPF (Open Shortest Path First)

OSPF is a routing protocol that determines the best path for routing IP traffic over a TCP/IP network based on link states between nodes and several quality parameters. OSPF is an interior gateway protocol (IGP), which is designed to work within an autonomous system. It is also a link state protocol, meaning that the best route is determined by the type and speed of the inter-router links, not by how many router hops they are away from each other (as in Distance-Vector routing protocols, i.e. Rip and RIP II).

BGP (Border Gateway Protocol)

BGPv4 is a path vector routing protocol where routing decisions are made based on the policies or rules laid out by the network administrator. It is typically used where networks are multihomed between multiple Internet Service Providers, or in very large internal networks where internal gateway protocols do not scale sufficiently.

Software Options

Feature	Layer 2 Standard Edition	Layer 3 Standard Edition	Layer 3 Security Options
VLANs (802.1Q)	✓	✓	✓
QoS (802.1p)	✓	✓	✓
MSTP (802.1Q-2005) formerly 802.1s	✓	✓	✓
RSTP	✓	✓	✓
eRSTP	✓	✓	✓
SNTP	✓	✓	✓
L2TPv2 and L2TPv3	✓	✓	✓
Port Rate Limiting	✓	✓	✓
Broadcast Storm Filtering	✓	✓	✓
Port Mirroring	✓	✓	✓
SNMP v1/v2/v3	✓	✓	✓
RMON	✓	✓	✓
CLI	✓	✓	✓
HTML User Interface	✓	✓	✓
MPLS		✓	✓
DHCP		✓	✓
VRRPv2 and VRRPv3		✓	✓
PIM-SM		✓	✓
Firewall		✓	✓
OSPF		✓	✓
BGP		✓	✓
RIP v1/v2		✓	✓
Traffic Prioritization		✓	✓
VPN			✓
IPSec			✓

EMI and Environmental Type Tests

IEC 61850-3 EMI TYPE TESTS				
TEST	Description		Test Levels	Severity Levels
IEC 61000-4-2	ESD	Enclosure Contact	+/- 8kV	4
		Enclosure Air	+/- 15kV	4
IEC 61000-4-3	Radiated RFI	Enclosure ports	20 V/m	Note 1
IEC 61000-4-4	Burst (Fast Transient)	Signal ports	+/- 4kV @ 2.5kHz	Note 1
		D.C. Power ports	+/- 4kV	4
		A.C. Power ports	+/- 4kV	4
		Earth ground ports	+/- 4kV	4
IEC 61000-4-5	Surge	Signal ports	+/- 2kV line-to-earth	4
		D.C. Power ports	+/- 2kV line-to-earth, +/- 1kV line-to-line	3
		A.C. Power ports	+/- 4kV line-to-earth, +/- 2kV line-to-line	4
IEC 61000-4-6	Induced (Conducted) RFI	Signal ports	10V	3
		D.C Power ports	10V	3
		A.C. Power ports	10V	3
		Earth ground ports	10V	3
IEC 61000-4-8	8 Magnetic Field	Enclosure ports	40 A/m continuous, 1000 A/m for 1 s 1000 A/m for 1 s	Note 1 5
IEC 61000-4-29	Voltage Dips & Interrupts	D.C. Power ports	30% for 0.1s, 60% for 0.1s, 100% for 0.05s	N/A
IEC 61000-4-11		A.C. Power ports	30% for 1 period, 60% for 50 periods	N/A
			100% for 5 periods, 100% for 50 periods	N/A
IEC 61000-4-12	Damped Oscillatory	Signal ports	2.5kV common, 1kV diff. mode@1MHz	3
		D.C. Power ports	2.5kV common, 1kV diff. mode@1MHz	3
		A.C. Power ports	2.5kV common, 1kV diff. mode@1MHz	3
IEC 61000-4-16	Mains Frequency Voltage	Signal ports	30V Continuous, 300V for 1s, 0-150KHz	4
		D.C. Power ports	30V Continuous, 300V for 1s, 0-150KHz	4
IEC 61000-4-17	Ripple on D.C. Power Supply	D.C. Power ports	10%	3
IEC 60255-5	Dielectric Strength	Signal ports	2kVac (Fail-Safe Relay output)	N/A
		D.C. Power ports	2kVac	N/A
		A.C. Power ports	2kVac	N/A
IEC 60255-5	H.V. Impulse	Signal ports	5kV (Fail-Safe Relay output)	N/A
		D.C. Power ports	5kV	N/A
		A.C. Power ports	5kV	N/A

IEEE 1613 (C37.90.x) EMI IMMUNITY TYPE TESTS ²				
Test	Description		Test Levels	
IEEE C37.90.3	ESD	Enclosure Contact	+/-2kV, +/-4kV, +/- 8kV	
		Enclosure Air	+/-4kV, +/-8kV, +/-15kV	
IEEE C37.90.2	Radiated RFI	Enclosure ports	35 V/m	
IEEE C37.90.1	Fast Transient	Signal ports	+/- 4kV @ 2.5kHz	
		D.C. Power ports	+/- 4kV	
		A.C. Power ports	+/- 4kV	
		Earth ground ports ³	+/- 4kV	
IEEE C37.90.1	Oscillatory	Signal ports	2.5kV common mode @1MHz	
		D.C. Power ports	2.5kV common, 1kV diff. mode@1MHz	
		A.C. Power ports	2.5kV common, 1kV diff. mode@1MHz	
IEEE C37.90	H.V. Impulse	Signal ports	5kV (Fail-Safe Relay output)	
		D.C. Power ports	5kV	
		A.C. Power ports	5kV	
IEEE C37.90	Dielectric Strength	Signal ports	2kVac	
		D.C. Power ports	2kVac	
		A.C. Power ports	2kVac	

Environmental Type Tests				
Test	Description		Test Levels	
IEC 60068-2-1	Cold Temperature	Test Ad	-40°C, 16 Hours	
IEC 60068-2-2	Dry Heat	Test Bd	+85°C, 16 Hours	
IEC 60068-2-30	Humidity (Damp Heat, Cyclic)	Test Db	95% (non-condensing), 55°C, 6 cycles	
IEC 60255-21-1	Vibration Response		Level 2 (1G @ 10-150 Hz)	
	Vibration Endurance		Level 2 (2G @ 10-150 Hz)	
IEC 60255-21-2	Shock Response		RX1510, RX1511: Level 1 (5G @ 11ms) / RX1512: Level 2 (10G @ 11ms)	
	Shock Withstand		Level 2 (30G @ 11ms)	

Notes: 1. RuggedCom specified severity levels
2. Meets Class 2 requirements for an all fiber configuration. Class 1 for copper ports.

Technical Specifications

Critical Alarm Relay

- Form-C contact relay: 5A@30VDC, 8A@250VAC

Switch Properties

- Switching method: Store & Forward
- Switching latency: 7 µs
- Switching bandwidth: 10Gbps
- MAC addresses: 8192
- MAC address table size: 64kbytes
- Priority Queues: 4
- Frame buffer memory: 1 Mbit
- VLANs: 255
- IGMP multicast groups: 256
- Port rate limiting
- No head of line blocking

Approvals

- ISO: Designed and manufactured using a ISO9001: 2008 certified quality program
- CE Marking
- Emissions: FCC Part 15 (Class A), EN55022 (CISPR22 Class A)
- Safety: cCSAus (Compliant with CSA C22.2 No. 60950, UL 60950, EN60950)
- Laser Eye Safety (FDA/CDRH): Complies with 21 CFR Chapter 1, Subchapter J.

Warranty

- 5 Years - Applicable to design and manufacturing related product defects.

Network Management

- HTTPS graphical web-based
- SNMP v1, v2c, v3
- Telnet, VT100
- Command Line Interface (CLI)
- SSH

IEC 61850 Compliance

- IEC 61850-9-2 Sampled Values
- IEC 61850-8-1 GOOSE Messages

EMI Immunity and Environmental Compliance

- IEC 61000-6-2 Industrial (Generic)
- IEC 61800-3 Industrial (Variable Speed Drive Systems)
- IEC 61850-3 Electric Utility Substations
- IEEE 1613 Electric Utility Substations
- NEMA TS 2 Traffic Control Equipment

IEEE Compliance

- 802.3-10BaseT
- 802.3u-100BaseTX, 100BaseFX
- 802.3x-Flow Control
- 802.3z-1000BaseLX
- 802.3ab-1000BaseTX
- Link Aggregation
- 802.1d-MAC Bridges
- 802.1d-Spanning Tree Protocol
- 802.1Q-VLAN Tagging
- 802.1w-Rapid Spanning Tree Protocol
- 802.1x-Port Based Network Access Control
- 802.1Q-2005 (formerly 802.1s) MSTP

IETF RFC Compliance

- RFC768-UDP
- RFC783-TFTP
- RFC791-IP
- RFC792-ICMP
- RFC793-TCP
- RFC826-ARP
- RFC854-Telnet
- RFC894-IP over Ethernet
- RFC1112-IGMP v1
- RFC1519-CIDR
- RFC1541-DHCP (client)
- RFC2030-SNTP
- RFC2068-HTTP
- RFC2236-IGMP v2
- RFC2284-EAP
- RFC2475-Differentiated Services
- RFC2865-RADIUS
- RFC3414-SNMPv3-USM
- RFC3415-SNMPv3-VACM
- RFC2661-L2TPv2
- RFC3931-L2TPv3
- RFC3768-VRRPv2
- RFC5798-VRRPv3

IETF SNMP MIBS

- RFC1493-BRIDGE-MIB
- RFC1907-SNMPv2-MIB
- RFC2012-TCP-MIB
- RFC2013-UDP-MIB
- RFC2578-SNMPv2-SMI
- RFC2579-SNMPv2-TC
- RFC2819-RMON-MIB
- RFC2863-IF-MIB
- draft-ietf-bridge-rstpmib-03-BRIDGE-MIB
- draft-ietf-bridge-bridgemib-smiv2-03-RSTP-MIB
- IANAifType-MIB

RX1510 Mechanical Drawing

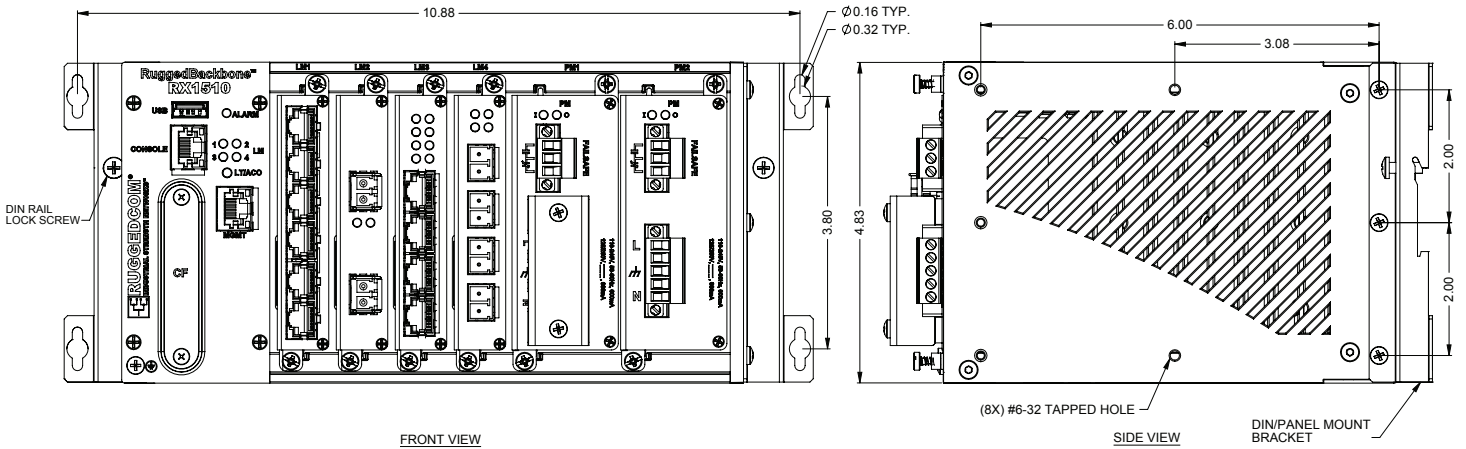
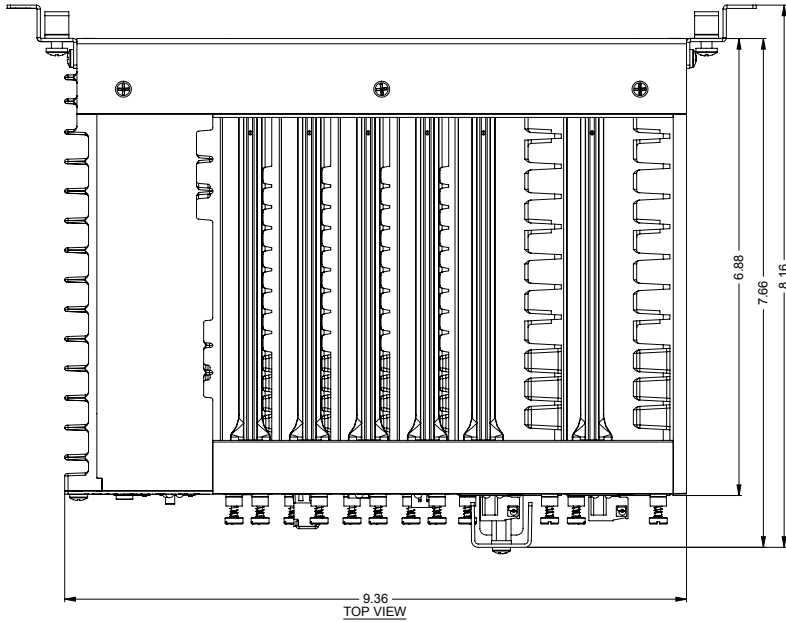

RX1511 Mechanical Drawing

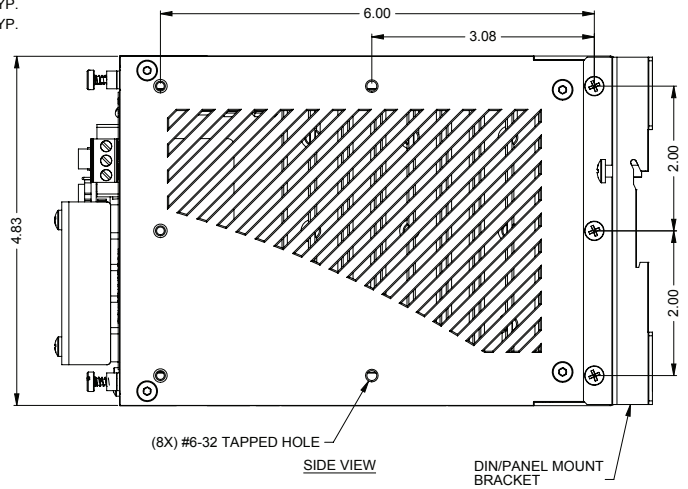
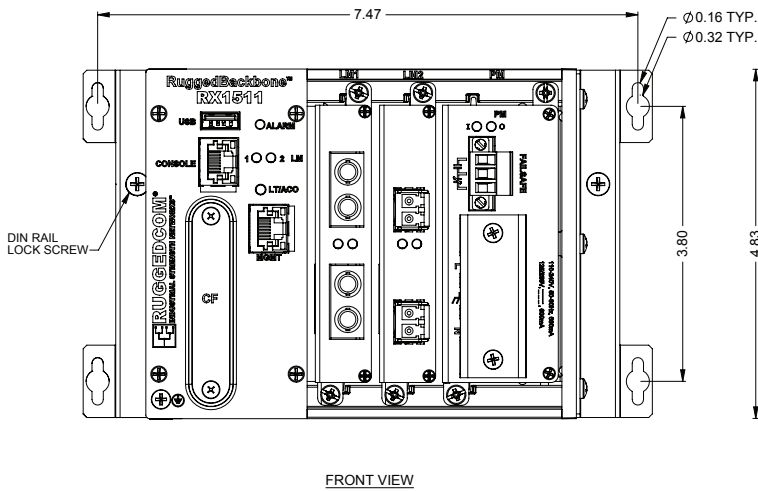
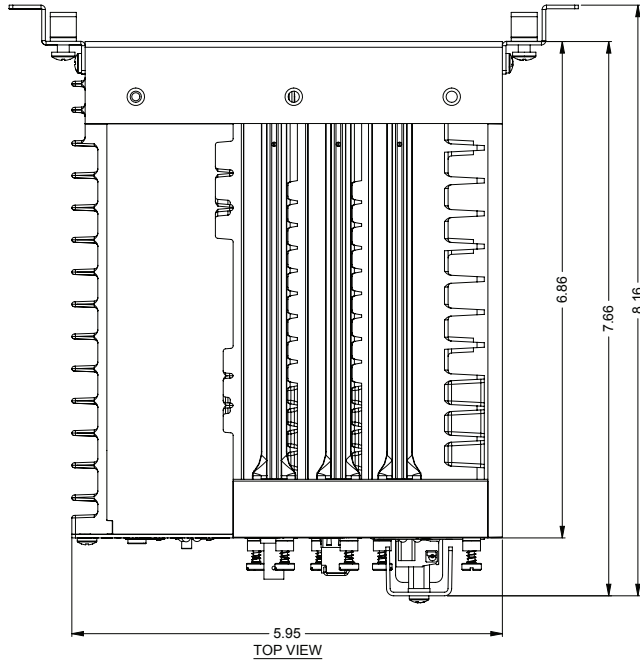

RX1512 Mechanical Drawing

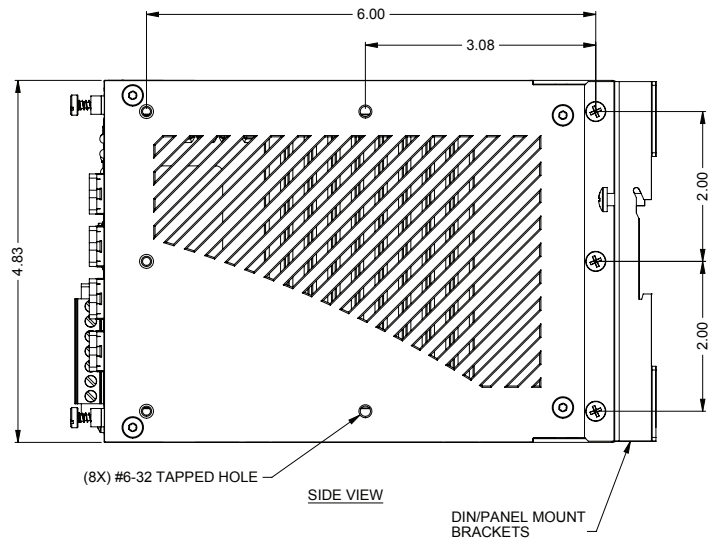
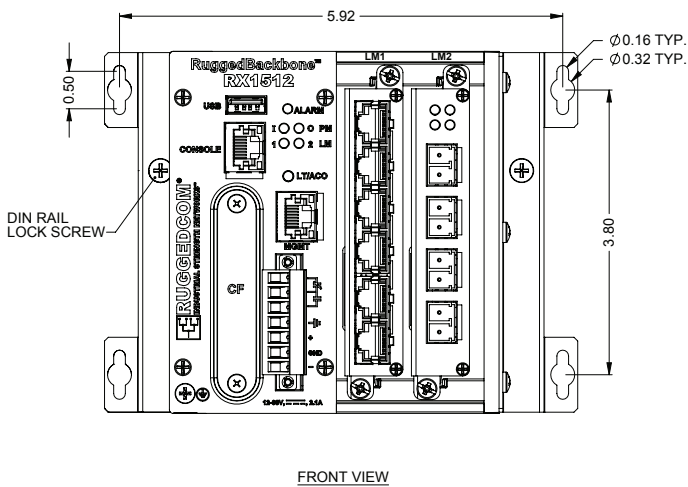
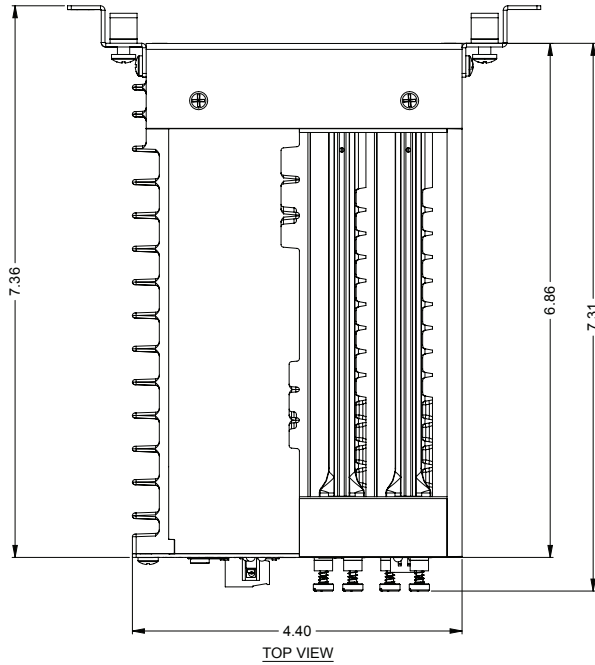

Order Codes

RX1510 - - - - - - - - - - -
ST MNT PM1 PM2 SFT LM1 LM2 LM3 LM4 MOD

RX1511 - - - - - - -
ST MNT PM1 SFT LM1 LM2 MOD

RX1512 - - - DC - - - -
ST MNT SFT LM1 LM2 MOD

ST: Switch Type Hardware

- L2 = Layer 2 Switch
- L3 = Layer 3 Switch

MNT: Mounting Options

- DPV = DIN and Panel Mount Kit
- 00 = No Mounting Option

PM1 and PM2: Power Modules

- HI = 88-300VDC or 85-264VAC screw terminal block
- HIP = 88-300VDC or 85-264VAC pluggable terminal block
- 24 = 24VDC (15-36VDC) screw terminal block
- 48 = 48VDC (36-72VDC) screw terminal block
- 24P = 24VDC (15-36VDC) pluggable terminal block
- 48P = 48VDC (36-72VDC) pluggable terminal block
- XXP = No Power Supply (PM2 only)
- DC = 10-72 VDC pluggable terminal block (RX1512 only)

SFT: Software

- L2SE = Layer 2 Standard Edition
- L3SEL3HW = Layer 3 Standard Edition (with L3 HW)
- L3SEL2HW = Layer 3 Standard Edition (with L2 HW)
- L3SECL3HW = Layer 3 Security Edition (with L3 HW)
- L3SECL2HW = Layer 3 Security Edition (with L2 HW)

LM1 through LM6 Line Modules

Blank Module

- XX = Blank Module

Copper Ethernet Modules

- 6TX01 = 6x 10/100TX RJ45
- CG01 = 2x 10/100/1000T RJ45⁽¹⁾

Serial Line Module

- S01 = 6x RS232/RS422/RS485 RJ45

100BaseFX modules with 2 Ports⁽¹⁾

- FX01 = 2x 100FX Multimode 1310nm ST 2km
- FX02 = 2x 100FX Multimode 1310nm SC 2km
- FX11 = 2x 100FX Multimode 1310nm LC 2km
- FX03 = 2x 100FX Multimode 1310nm MTRJ 2km
- FX04 = 2x 100FX Singlemode 1310nm ST 20km
- FX05 = 2x 100FX Singlemode 1310nm SC 20km
- FX06 = 2x 100FX Singlemode 1310nm LC 20km
- FX07 = 2x 100FX Singlemode 1310nm SC 50km
- FX08 = 2x 100FX Singlemode 1310nm LC 50km
- FX09 = 2x 100FX Singlemode 1310nm SC 90km
- FX10 = 2x 100FX Singlemode 1310nm LC 90km

10BaseFL / 100BaseSX with 3 Ports

- FL01 = 3x 10FL/100SX Multimode 850nm ST 2km

100BaseFX modules with 4 Ports

- 4FX11 = 4x 100FX Multimode 1310nm LC 2km
- 4FX03 = 4x 100FX Multimode 1310nm MTRJ 2km
- 4FX06 = 4x 100FX Singlemode 1310nm LC 20km
- 4FX08 = 4x 100FX Singlemode 1310nm LC 50km
- 4FX10 = 4x 100FX Singlemode 1310nm LC 90km
- FX50 = 4x 100FX SFP Blank (no optical transceiver)
- FX51 = 4x 100FX SFP Multimode 1310 nm LC 2km
- FX52 = 4x 100LX SFP Singlemode 1310 nm LC 20km
- FX53 = 4x 100LX SFP Singlemode 1310 nm LC 50km
- FX54 = 4x 100LX SFP Singlemode 1550 nm LC 90km

100BaseFX modules with 6 Ports

- 6FX50 = 6x 100FX SFP Blank (no optical transceiver)
- 6FX51 = 6x 100FX SFP Multimode 1310 nm LC 2km
- 6FX52 = 6x 100LX SFP Singlemode 1310 nm LC 20km
- 6FX53 = 6x 100LX SFP Singlemode 1310 nm LC 50km
- 6FX54 = 6x 100LX SFP Singlemode 1550 nm LC 90km

Gigabit Ethernet Modules modules with 2 Ports⁽¹⁾

- FG01 = 2x 1000SX Multimode 850 nm LC 500m
- FG02 = 2x 1000LX Singlemode 1310 nm SC 10km
- FG03 = 2x 1000LX Singlemode 1310 nm LC 10km
- FG04 = 2x 1000LX Singlemode 1310 nm SC 25km
- FG05 = 2x 1000LX Singlemode 1310 nm LC 25km
- FG50 = 2x 1000LX SFP Blank (no optical transceiver)
- FG51 = 2x 1000SX SFP Multimode 850 nm LC 500m
- FG52 = 2x 1000LX SFP Singlemode 1310 nm LC 10km
- FG53 = 2x 1000LX SFP Singlemode 1310 nm LC 25km
- FG54 = 2x 1000LX SFP Singlemode 1550 nm LC 70km

WAN Port Options⁽²⁾

- TC1 = 1x T1/E1 RJ48 (Channelized)
- TC2 = 2x T1/E1 RJ48 (Channelized)
- TC4 = 4x T1/E1 RJ48 (Channelized)
- E01 = 1x E1 75 Ohms BNC (Channelized)
- E02 = 2x E1 75 Ohms BNC (Channelized)
- W11 = 1x GSM/EDGE/HSPA⁽³⁾⁽⁴⁾
- W12 = 2x GSM/EDGE/HSPA⁽³⁾⁽⁴⁾
- W21 = 1x EVDO rev A Verizon US⁽³⁾⁽⁵⁾
- W22 = 2x EVDO rev A Verizon US⁽³⁾⁽⁵⁾
- W32 = 2x GSM/EDGE/HSPA and EVDO rev A Verizon US⁽³⁾⁽⁴⁾⁽⁵⁾
- D02 = 1k DDS RJ48 (56k Master/Slave 64k Slave)

Order Codes

Application Processing Engine:⁽⁶⁾⁽⁷⁾

- APE1402 = 1.3GHz, 2GB RAM, 8GB SATA, DVI-D Video, 2xUSB, Linux
- APE1402W7 = 1.3GHz, 2GB RAM, 8GB SATA, DVI-D Video, 2xUSB, Windows 7 Embedded
- APE1404 = 1.3GHz, 2GB RAM, 16GB SATA, DVI-D Video, 2xUSB, Linux
- APE1404W7 = 1.3GHz, 2GB RAM, 16GB SATA, DVI-D Video, 2xUSB, Windows 7 Embedded
- APE1404CKP = 1.3GHz, 2GB RAM, 16GB SATA, DVI-D Video, 2xUSB, Checkpoint FW (requires Checkpoint license)

M12 Copper Ethernet Modules

- CG03 = 2x 10/100/1000TX A-coded M12
- CG04 = 2x 10/100/1000TX X-coded M12
- 4TX03 = 4x 10/100TX 8-pin A-coded M12
- 4TX04 = 4x 10/100TX 4-pin D-coded M12
- CG03B = 2x 10/100/1000TX A-coded M12 with Controlled Bypass
- CG04B = 2x 10/100/1000TX X-coded M12 with Controlled Bypass
- 4TX03B = 4x 10/100TX 8-pin A-coded with M12 Controlled Bypass
- 4TX04B = 4x 10/100TX 4-pin D-coded with M12 Controlled Bypass

MOD: Hardware Modifications

- XX = None
- C01 = With Conformal Coating

Notes:

1. On the RX1501 these modules may only be selected for LM1 and LM2
2. Only one T1/E1 module may be used per router, WAN modules require L3 software
3. Carrier approvals may be required
4. HSPA module is rated from -25°C to +75°C
5. EVDO module is rated from -30°C to +75°C
6. APE module is rated from -40°C to +70°C
7. Maximum 2 APEs can be installed in a chassis

Example Order Codes:

RX1510-L3-DPV-HI-HI-L3SEL3HW-FX01-FX01-6TX01-TC1-XX

One Layer 3 RX1510 unit, DIN Mounted, with 2 (two) HI power supplies, 2 (two) 2-Port 100FX Multimode line modules, 1 (one) 6-Port 10/100TX module, one Single T1/E1 via RJ45 module, running Layer 3 Standard Edition firmware

RX1511-L3-DPV-HI-L3SEL3HW-4FX01-4FX01-XX

One Layer 3 RX1511 unit, DIN Mounted, with a HI power supply, 2 (two) 4-Port 100FX Multimode line modules, running Layer 3 Standard Edition firmware

RX1512-L2-00-DC-L3SEL3HW-CG01-6TX01-XX

One Layer 2 RX1512 unit, no mounting option, with a built-in wide range 11-72V DC power supply, 1 (one) 2-Port 10/100/1000TX line module, and 1 (one) 6-Port 10/100TX line module. The RX1512 is running Layer 3 Standard Edition firmware

Accessories/Options:

Fast Ethernet SFPs

- 99-25-0003 = 100FX SFP Multimode LC 1310nm 2km
- 99-25-0004 = 100FX SFP Singlemode LC 1310nm 20km
- 99-25-0005 = 100FX SFP Singlemode LC 1310nm 50km
- 99-25-0006 = 100FX SFP Singlemode LC 1310nm 90km

Gigabit SFPs

- 99-25-0111 = 1000SX SFP Multimode LC 850nm 500m
- 99-25-0100 = 1000LX SFP Singlemode LC 1310nm 10km
- 99-25-0101 = 1000LX SFP Singlemode LC 1310nm 25km
- 99-25-0109 = 1000LX SFP Singlemode LC 1550nm 70km

Bidirection SFPs

- 99-25-0206 = 1000BX SFP Singlemode LC 1310Tx 1490Rx 10km
- 99-25-0207 = 1000BX SFP Singlemode LC, 1490Tx 1310Rx 10km
- 99-25-0208 = 1000BX SFP Singlemode LC 1310Tx 1490Rx 40km
- 99-25-0209 = 1000BX SFP Singlemode LC 1490Tx 1310Rx 40km

Antennas

- 99-01-0001-001 = Dual Band Antenna for use with the W21, W22 or W32 Option
- 99-01-0002-001 = 7 Band Antenna for use with the W11, W12 or W32 Option

Individual Parts Order Codes

Any of the modules, Power, Control, Switch or Line Modules, may be ordered as individual parts. An empty chassis and brackets may also be ordered as single pieces.

RX1500PN – _____ – _____
 PT **MOD**

PT: Individual Part to be ordered

The Part may be chosen from MNT or any module from the RX1500 order codes page. By specifying a module you are selecting a line module that may be seated into the RX1500 unit without any cabling. By specifying a MNT option you are selecting brackets for the RX1500

Additional Part numbers used for Software Upgrades:

- SFTUP1 = Layer 2 Standard Edition to Layer 3 Standard Edition
- SFTUP2 = Layer 2 Standard Edition to Layer 3 Security Edition
- SFTUP3 = Layer 3 Standard Edition to Layer 3 Security Edition

MOD: Hardware Modifications

- XX = None
- C01 = with Conformal Coating

Example Order Codes for ordering parts

RX1500PN-HI-XX

- This is one HI power supply module

RX1500PN-6TX01-XX

- This is one 6-port 10/100BaseTX line module, for the RX1500, with RJ45 connectors

RX1500PN- SFTUP1-XX

- This order code is used to request a license key to upgrade a RX1500 from Layer 2 Standard Edition to Layer 3 Standard Edition software

Siemens Canada Limited
300 Applewood Crescent
Concord, ON, Canada L4K 5C7

Tel: +1 (905) 856-5288 **Fax:** +1 (905) 856-1995
Toll Free: 1 (888) 264-0006
Technical Support Center: 1 (866) 922-7975

© 2014 Siemens Canada Limited
RuggedBackbone is a Registered trademark of RuggedCom Inc.
Ethernet is a trademark of the Xerox Corporation.
Patent Pending
All specifications in this document are subject to change without notice.

Rev 1u – 02/03/14

For additional information on our products and services, please visit our website at: www.RuggedCom.com