



# SIEMENS

## Product Overview

# RUGGEDCOM RS900G

## 10-port Managed Ethernet Switch With Gigabit Uplink Ports, 128-bit Encryption

The RUGGEDCOM RS900G from Siemens is a utility grade, fully managed Ethernet switch providing dual fiber optical gigabit Ethernet ports and eight Fast Ethernet copper ports.

Designed to operate reliably in harsh environments, the RS900G provides a high level of immunity to electromagnetic interference and heavy electrical surges typical of environments found in electric utility substations, curb side traffic control cabinets, and factory floors. An operating temperature range of  $-40^{\circ}\text{C}$  to  $+85^{\circ}\text{C}$  coupled with hazardous location compliance, optional conformal coating and a galvanized steel enclosure allows the RS900G to be placed in almost any location.

The RS900G provides two fiber optical Gigabit Ethernet ports for creating a fiber optical backbone with high noise immunity and long haul connectivity. The versatility and wide selection of fiber optics allows the RS900G to be used in a variety of applications.

The embedded Rugged Operating System (ROS) provides advanced cyber security features and comprehensive networking functions such as Enhanced Rapid Spanning

Tree (eRSTP), Port Rate Limiting, and a full array of intelligent functionality for high network availability and manageability. Coupled with the ruggedness and durability that is designed in from the onset, the RS900G is ideal for creating mission-critical, real-time, control applications where high reliability and availability is of paramount importance.

All RUGGEDCOM products are backed by a five year warranty and unsurpassed technical support.



[usa.siemens.com/ruggedcom](http://usa.siemens.com/ruggedcom)



## Features and Benefits

### Ethernet Ports

- 2 - Fiber optical Gigabit Ethernet ports (1000BaseX)
- 8 - Fast Ethernet ports (10/100BaseTX)
- Multiple fiber connector types (LC, SC, SFP pluggable optics)
- Bi-directional singlestrand fiber support
- Long haul optics allow Gigabit distances up to 70km

### Cyber Security Features

- Multi-level user passwords
- SSH/SSL/SFTP (128-bit encryption)
- Enable/disable ports, MAC based port security
- Port based network access control (802.1x)
- VLAN (802.1Q) to segregate and secure network traffic
- RADIUS centralized password management
- SNMPv3 authentication and 56-bit encryption

### Rugged Rated for Reliability in Harsh Environments

- Immunity to EMI and heavy electrical surges
  - Meets IEEE 1613 (electric utility substations)
  - Exceeds IEC 61850-3 (electric utility substations)
  - Exceeds IEC 61800-3 (variable speed drive systems)
  - Exceeds IEC 61000-6-2 (generic industrial)
  - Exceeds NEMA TS-2 (traffic control equipment)
- Hazardous Location Compliance: Class 1 Division 2
- -40 to +85°C operating temperature (no fans)
- Conformal coated printed circuit boards (optional)

### Rugged Operating System (ROS) Features

- Simple plug and play operation – automatic learning, negotiation, and crossover detection
- MSTP 802.1Q-2005 (formerly 802.1s)
- RSTP (802.1w) and Enhanced Rapid Spanning Tree (eRSTP) network fault recovery (<5ms)
- Quality of Service (802.1p) for real-time traffic
- VLAN (802.1Q) with double tagging and GVRP support
- Link aggregation (802.3ad)
- IGMP snooping for multicast filtering
- Port rate limiting and broadcast storm limiting
- Industrial automation features (eg. Modbus)

### Management Tools

- Web-based, Telnet, CLI management interfaces
- SNMP v1/v2/v3 (56-bit encryption)
- Remote Monitoring (RMON)
- Rich set of diagnostics with logging and alarms

### Universal Power Supply Options

- Fully integrated power supply (no external adaptors)
- Popular low-voltage DC ranges: 24VDC (10-36VDC) or 48VDC (36-72VDC)
- Universal high-voltage range: 88-300VDC or 85-264VAC
- CSA/UL 60950 safety approved to +85°C
- Screw connection terminal blocks ensure reliable maintenance free connections





## RUGGEDCOM RS900G

### Dual Gigabit Ports

- ▶ Pluggable optics (SFP)
- ▶ LC or SC connectors
- ▶ Bi-directional (single strand)
- ▶ Distances up to 70km

### Hazardous Location Compliance

- ▶ Class 1, Division 2

### Fast Ethernet Ports

- ▶ 8 - Fast Ethernet ports (10/100BaseTX)



### Operating Temperature

- ▶ -40°C to +85°C
- ▶ No fans

### Rugged Construction

- ▶ 20 AWG galvanized steel enclosure
- ▶ Conformal coating (optional)

### Integrated Power Supply

- ▶ Universal high-voltage range:  
88-300VDC or  
85-264VAC
- ▶ Popular low voltage DC ranges:  
24VDC (10-36VDC)  
48VDC (36-72VDC)
- ▶ Dual isolated DC power inputs

### Critical Alarm Relay

- ▶ Form-C failsafe contact relay:  
1A@30VDC

### Mounting Options

- ▶ DIN rail
- ▶ Panel mount

# ROS Features

## Cyber Security

Cyber security is an urgent issue in many industries where advanced automation and communications networks play a crucial role in mission critical applications and where high reliability is of paramount importance. Key ROS features that address security issues at the local area network level include:

- **Passwords** – Multi-level user passwords secures switch against unauthorized configuration
- **SSH / SSL** – Extends capability of password protection to add 128-bit encryption of passwords and data as they cross the network
- **Enable/Disable ports** – Capability to disable ports so that traffic can not pass
- **802.1Q VLAN** – Provides the ability to logically segregate traffic between predefined ports on switches
- **MAC based port security** – The ability to secure ports on a switch so only specific Devices / MAC addresses can communicate via that port
- **802.1x Port based network access control** – The ability to lock down ports on a switch so that only authorized clients can communicate via this port
- **RADIUS** – authentication service using MD5 hash and providing centralized password management
- **SNMPv3** – encrypted authentication access security and data encryption (CBC-DES with 56-bit encryption key)
- **Secure socket layer** – Web-based management using SSL with data encryption (128-bit encryption key)
- **RSA** – 1024 bit key for key management and key exchange
- **TACACS+** – Terminal Access Control and Accounting Services. Client provides encrypted authentication and authorization
- **Point to Point (PPP)** – using CHAP (MD5 Hash) authentication service
- **SFTP** – Secure File Transfer Protocol using SSH encryption

The ROS cyber security features are included to help address the various industry specific security standards such as NERC CIP, ISA 999, AGA 12, IEC 62443, ISO 17799:2005 and PCSRF SPP-ICS.

## Enhanced Rapid Spanning Tree Protocol (eRSTP)

RUGGEDCOM eRSTP allows the creation of fault-tolerant ring and mesh Ethernet networks that incorporate redundant links that are 'pruned' to prevent loops. eRSTP yields worst-case fault recovery<sup>1</sup> of 5ms times the 'bridge diameter' and allows rings of up to 160 switches. For example, a ring of ten switches will have fault recovery times under 50ms. eRSTP implements both STP and RSTP to ensure interoperability with commercial switches unlike other proprietary 'ring' solutions.

<sup>1</sup> eRSTP fault recovery times may be approximated as follows:  
For 100 Mbps, fault recovery performance is <5ms/hop  
For 1,000 Mbps, fault recovery performance is <5ms/hop + 20ms

## Quality of Service (IEEE 802.1p)

Some networking applications such as real-time control or VoIP (voice over IP) require predictable arrival times for Ethernet frames. Switches can introduce latency in times of heavy network traffic due to the internal queues that buffer frames and then transmit on a first come first serve basis. ROS supports 'Class of Service' in accordance with IEEE 802.1p that allows time critical traffic to jump ahead to the front of the queue thus minimizing latency and reducing jitter to allow such demanding applications to operate correctly. ROS allows priority classification by port, tags, MAC address, and IP type of service (ToS). A configurable "weighted fair queuing" algorithm controls how frames are emptied from the queues.

## VLAN (IEEE 802.1Q)

Virtual local area networks (VLAN) allow the segregation of a physical network into separate logical networks with independent broadcast domains. A measure of security is provided since hosts can only access other hosts on the same VLAN and traffic storms are isolated. ROS supports 802.1Q tagged Ethernet frames and VLAN trunks. Port based classification allows legacy devices to be assigned to the correct VLAN. GVRP support is also provided to simplify the configuration of the switches on the VLAN.

## Link Aggregation (802.3ad)

The link aggregation feature provides the ability to aggregate several Ethernet ports into one logical link (port trunk) with higher bandwidth. This provides an inexpensive way to set up a high speed backbone to improve network bandwidth. This feature is also known as "port trunking," "port bundling," "port teaming," and "Ethernet trunk."

## IGMP Snooping

ROS uses IGMP snooping (Internet Group Management Protocol v1&v2) to intelligently forward or filter multicast traffic streams (e.g. MPEG video) to or from hosts on the network. This reduces the load on network trunks and prevents packets from being received on hosts that are not involved. ROS has a very powerful implementation of IGMP snooping that:

- Can be enabled on a per VLAN basis
- Detects and filters all multicast streams regardless of whether subscribers exist
- Supports "router-less" operation by supporting an "active" mode
- Restores traffic streams immediately after an RSTP topology change

## ROS Features

### SNMP (Simple Network Management Protocol)

SNMP provides a standardized method for network management stations to interrogate devices from different vendors. SNMP versions supported by ROS are v1, v2c, and v3. SNMPv3, in particular, provides security features such as authentication, privacy with data encryption (CBC-DES with 56-bit encryption key) and access control not present in earlier SNMP versions. ROS also supports numerous standard MIBs (Management Information Base) allowing for easy integration with any network management system (NMS).

A feature of SNMP supported by ROS is the ability to generate “traps” upon system events. RUGGEDCOM NMS, the RUGGEDCOM management solution, can record traps from multiple devices providing a powerful network troubleshooting tool. It also provides a graphical visualization of the network and is fully integrated with all RUGGEDCOM products.

### SNTP (Simple Network Time Protocol)

SNTP automatically synchronizes the internal clock of all ROS devices on the network. This allows for correlation of time stamped events for troubleshooting.

### SCADA and Industrial Automation

ROS contains features that optimize network performance and simplify switch management based on the unique requirements found in SCADA and industrial automation applications. Features such as Modbus TCP management for retrieval of switch data using the ubiquitous Modbus protocol and DHCP Option 82, a Rockwell Automation ODVA requirement for IP address assignment based on the location of the end device, provide capabilities not found in typical “commercial” or “office grade” Ethernet switches.

### Port Based Network Access Control (802.1x)

ROS supports the IEEE 802.1x standard that defines a mechanism for port-based network access control which provides a means of authenticating and authorizing devices attached to LAN ports.

### Port Rate Limiting

ROS supports configurable rate limiting per port to limit unicast and multicast traffic. This can be essential to managing precious network bandwidth for service providers. It also provides edge security for denial of service (DoS) attacks.

### Broadcast Storm Filtering

Broadcast storms wreak havoc on a network and can cause attached devices to malfunction. This could be disastrous on a network with mission critical equipment. ROS limits this by filtering broadcast frames with a user-defined threshold.

### Port Mirroring

ROS can be configured to duplicate all traffic on one port to a designated mirror port. When combined with a network analyzer, this can be a powerful troubleshooting tool.

Some intelligent electronic devices (IEDs) have dual fiber optic ports with automatic failover to a backup port should the primary fail. ROS ensures this mechanism works reliably under all failure modes by appropriately disabling link signals when required. ROS also flushes learned MAC addresses to ensure the failover occurs quickly.

### Port Configuration and Status

ROS allows individual ports to be ‘hard’ configured for speed, duplex, auto-negotiation, flow control and more. This allows proper connection with devices that do not negotiate or have unusual settings. Detailed status of ports with alarm and SNMP trap on link problems aid greatly in system troubleshooting.

### Port Statistics and RMON (Remote Monitoring)

ROS provides continuously updating statistics per port that provide both ingress and egress packet and byte counters as well as detailed error figures. Also provided is full support for the RMON statistics, history, alarms, and event groups. RMON allows for very sophisticated data collection, analysis and detection of traffic patterns.

### Event Logging and Alarms

ROS records all significant events to a non-volatile system log allowing forensic troubleshooting. Events include link failure and recovery, unauthorized access, broadcast storm detection, and self-test diagnostics among others. Alarms provide a snapshot of recent events that have yet to be acknowledged by the network administrator. An external hardware relay is de-energized during the presence of critical alarms allowing an external controller to react if desired.

### HTML Web Browser and Telnet/SSH User Interfaces

ROS provides a simple, intuitive user interface for configuration and monitoring via a standard graphical web browser or via Telnet/SSH. All system parameters include detailed on-line help to make setup a breeze. ROS, presents a common look and feel and standardized configuration process allowing easy migration to other RUGGEDCOM managed products.

### Configuration Via ASCII Text File

All configuration parameters are stored in an ASCII formatted text file that can easily be transferred via TFTP, SFTP or Xmodem. The configuration file can be saved for backup purposes and easily manipulated by a text editor. The same text file can be downloaded to the switch at a later date in order to re-configure or restore a previous configuration.

### Command Line Interface (CLI)

A command line interface can be used in conjunction with remote shell to automate data retrieval, configuration updates, and firmware upgrades. A powerful SQL-like capability allows expert users the ability to selectively retrieve or manipulate any parameters the device has to offer.

## EMI and Environmental Type Tests

IEC 61850-3 EMI Type Tests					
Test	Description		Test Levels	Severity Levels	
IEC 61000-4-2	ESD	Enclosure contact	+/- 8kV	4	
		Enclosure air	+/- 15kV	4	
IEC 61000-4-3	Radiated RFI	Enclosure ports	20 V/m	x	
IEC 61000-4-4	Burst (fast transient)	Signal ports	+/- 4kV @ 2.5kHz	x	
		D.C. power ports	+/- 4kV	4	
		A.C. power ports	+/- 4kV	4	
		Earth ground ports <sup>3</sup>	+/- 4kV	4	
IEC 61000-4-5	Surge	Signal ports	+/- 4kV line-to-earth, +/- 2kV line-to-line	4	
		D.C. power ports	+/- 2kV line-to-earth, +/- 1kV line-to-line	3	
		A.C. power ports	+/- 4kV line-to-earth, +/- 2kV line-to-line	4	
IEC 61000-4-6	Induced (conducted) RFI	Signal ports	10V	3	
		D.C power ports	10V	3	
		A.C. power ports	10V	3	
		Earth ground ports <sup>3</sup>	10V	3	
IEC 61000-4-8	Magnetic field	Enclosure ports	40 A/m continuous, 1000 A/m for 1 s	N/A	
			1000 A/m for 1 s	N/A	
IEC 61000-4-29	Voltage dips and interrupts	D.C. power ports	30% for 0.1s, 60% for 0.1s, 100% for 0.05s	N/A	
IEC 61000-4-11		A.C. power ports	30% for 1 period, 60% for 50 periods	N/A	
IEC 61000-4-12	Damped oscillatory	Signal ports	100% for 5 periods, 100% for 50 periods <sup>2</sup>	N/A	
			D.C. power ports	2.5kV common, 1kV diff. mode@1MHz	3
			A.C. power ports	2.5kV common, 1kV diff. mode@1MHz	3
IEC 61000-4-16	Mains frequency voltage	Signal ports	30V Continuous, 300V for 1s	4	
		D.C. power ports	30V Continuous, 300V for 1s	4	
IEC 61000-4-17	Ripple on D.C. power supply	D.C. power ports	10%	3	
IEC 60255-5	Dielectric strength	Signal ports	2kVac (Fail-safe relay output)	N/A	
		D.C. power ports	1.5V DC	N/A	
		A.C. power ports	2kVac	N/A	
IEC 60255-5	H.V. impulse	Signal ports	5kV (Fail-safe relay output)	N/A	
		D.C. Power ports	5kV	N/A	
		A.C. Power ports	5kV	N/A	

IEEE 1613 (C37.90.x) EMI Immunity Type Tests				
Test	Description		Test Levels	Severity Levels
IEEE C37.90.3	ESD	Enclosure contact	+/- 8kV	N/A
		Enclosure air	+/-15kV	N/A
IEEE C37.90.2	Radiated RFI	Enclosure ports	35 V/m	N/A
IEEE C37.90.1	Fast transient	Signal ports	+/- 4kV @ 2.5kHz	N/A
		D.C. power ports	+/- 4kV	N/A
		A.C. power ports	+/- 4kV	N/A
		Earth ground ports <sup>3</sup>	+/- 4kV	N/A
IEEE C37.90.1	Oscillatory	Signal ports	2.5kV common mode@1MHz	N/A
		D.C. power ports	2.5kV common, 1kV diff. mode@1MHz	N/A
		A.C. power ports	2.5kV common, 1kV diff. mode@1MHz	N/A
IEEE C37.90	H.V. impulse	Signal ports	5kV (Fail-safe relay output)	N/A
		D.C. power ports	5kV	N/A
		A.C. power ports	5kV	N/A
IEEE C37.90.	Dielectric strength	Signal ports	2kVac	N/A
		D.C. power ports	1.5kVac	N/A
		A.C. power ports	2kVac	N/A

Environmental Type Tests				
Test	Description		Test Levels	Severity Levels
IEC 60068-2-1	Cold temperature	Test Ad	-40°C, 16 hours	N/A
IEC 60068-2-2	Dry heat	Test Bd	+85°C, 16 hours	N/A
IEC 60068-2-30	Humidity (damp heat, cyclic)	Test Db	95% (non-condensing), 55°C , 6 cycles	N/A
IEC 60255-21-1	Vibration	Test Fc	2g @ (10 - 150) Hz	Class 2 <sup>2</sup>
IEC 60255-21-2	Shock	Test Ea	30g @ 11mS	Class 2 <sup>2</sup>

<sup>1</sup> RUGGEDCOM specified severity levels.

<sup>2</sup> Class 2 refers to "Measuring relays and protection equipment for which a very high security margin is required or where the vibration levels are very high, (e.g. shipboard application and for severe transportation conditions)".

<sup>3</sup> Only applicable to functional earth connections separated from the safety earth connection.

# Technical Specifications

## Power Supply

- Power consumption: 32W Max
- 24VDC: 10-36 VDC, 0.4A
- 48VDC: 36-72 VDC, 0.2A
- Hi voltage AC/DC: 88-300VDC or 85-264VAC

## Critical Alarm Relay

- Form-C failsafe contact relay:  
1A@30VDC

## Physical Dimensions

- Height: 7.4" (188mm)
- Width: 2.6" (66mm)
- Depth: 5.0" (127mm)
- Weight: 1.22kg
- Ingress protection: IP40 (1mm objects)
- Enclosure: 20 AWG galvanized steel enclosure
- Mounting: DIN rail or panel mounted

## Switch Properties

- Switching method: Store and forward
- Switching latency: 8 us (100Mbps)
- Switching bandwidth: 1.8 Gbps
- MAC addresses: 8192
- Priority queues: 4
- Frame buffer memory: 1 Mbit
- Simultaneous VLANs: 255
- VLAN ID range: 1 to 4094
- IGMP multicast groups: 256
- Port rate limiting: 128kbps, 256, 512, 4, 8Mbps
- No head of line blocking

## Regulatory Approvals

- ISO: Designed and manufactured using an ISO9001: 2000 certified quality program
- CE marking
- Emissions: FCC Part 15 (Class A), EN55022 (CISPR22 Class A)
- Safety: cCSAus (Compliant with CSA C22.2 No. 60950, UL 60950, EN60950)
- Laser eye safety (FDA/CDRH): Complies with 21 CFR Chapter 1, Subchapter J

## Network Management

- HTTPS graphical web-based, SSL (128-bit encryption)
- SNMP v1, v2c, v3 (56-bit encryption)
- Telnet, VT100, SSH/SFTP (128-bit encryption)
- Command Line Interface (CLI)
- RSA key management (1024 bit key)
- Authentication and accounting - TACACS+ (encrypted), RADIUS client, PPP

## Warranty

- 5 Years – Applicable to design and manufacturing related product defects.

## EMI Immunity and Environmental Compliance

- IEC 61000-6-2 Industrial (Generic)
- IEC 61800-3 Industrial (Variable Speed Drive Systems)
- IEC 61850-3 Electric Utility Substations
- IEEE 1613 Electric Utility Substations
- NEMA TS 2 Traffic Control Equipment
- Hazardous Locations: Class 1, Division 2

## IEEE Compliance

- 802.3-10BaseT
- 802.3u-100BaseTX, 100BaseFX
- 802.3x-Flow Control
- 802.3ad-Link Aggregation
- 802.1D-MAC Bridges
- 802.1D-Spanning Tree Protocol
- 802.1p-Class of Service
- 802.1Q-VLAN Tagging
- 802.1w-Rapid Spanning Tree Protocol
- 802.1x-Port Based Network Access Control
- 802.1Q-2005 (formerly 802.1s) MSTP

## IETF RFC Compliance

- RFC768-UDP
- RFC783-TFTP
- RFC791-IP
- RFC792-ICMP
- RFC793-TCP
- RFC826-ARP
- RFC854-Telnet
- RFC894-IP over Ethernet
- RFC1112-IGMP v1
- RFC1519-CIDR
- RFC1541-DHCP (client)
- RFC2030-SNTP
- RFC2068-HTTP
- RFC2236-IGMP v2
- RFC2284-EAP
- RFC2475-Differentiated Services
- RFC2865-RADIUS
- RFC3414-SNMPv3-USM
- RFC3415-SNMPv3-VACM

## IETF SNMP MIBS

- RFC1493-BRIDGE-MIB
- RFC1907-SNMPv2-MIB
- RFC2012-TCP-MIB
- RFC2013-UDP-MIB
- RFC2578-SNMPv2-SMI
- RFC2579-SNMPv2-TC
- RFC2819-RMON-MIB
- RFC2863-IF-MIB
- draft-ietf-bridge-rstpmib-03-BRIDGE-MIB
- draft-ietf-bridge-bridgemib-smiv2-03-RSTP-MIB
- IANAifType-MIB



# Fiber Specifications and Dimension Drawings

Fiber Optical Specifications				
Parameter	Fiber Port Type			
Mode	Multimode	Singlemode	Singlemode	Singlemode
Connector	LC, LC-SFP	SC, LC, LC-SFP	SC, LC, LC-SFP	LC-SFP
Typical Dist. (km)	500m	10km	25km	70km
Optical Wavelength (nm)	850	1310	1310	1550
Cable Size Core/Cladding (um)	50 / 125 or 62.5 / 125	8 / 125 or 9 / 125	8 / 125 or 9 / 125	8 / 125 or 9 / 125
TX Power (Min/Max) (dBm)	-9.5 / -4	-9/-3	-7 / -3	0 / 5
RX Sensitivity (dBm)	-20	-22	-26	-23
RX Saturation (dBm)	0-	-3	-3	0
Typical Budget (dB)	14	17	19	25

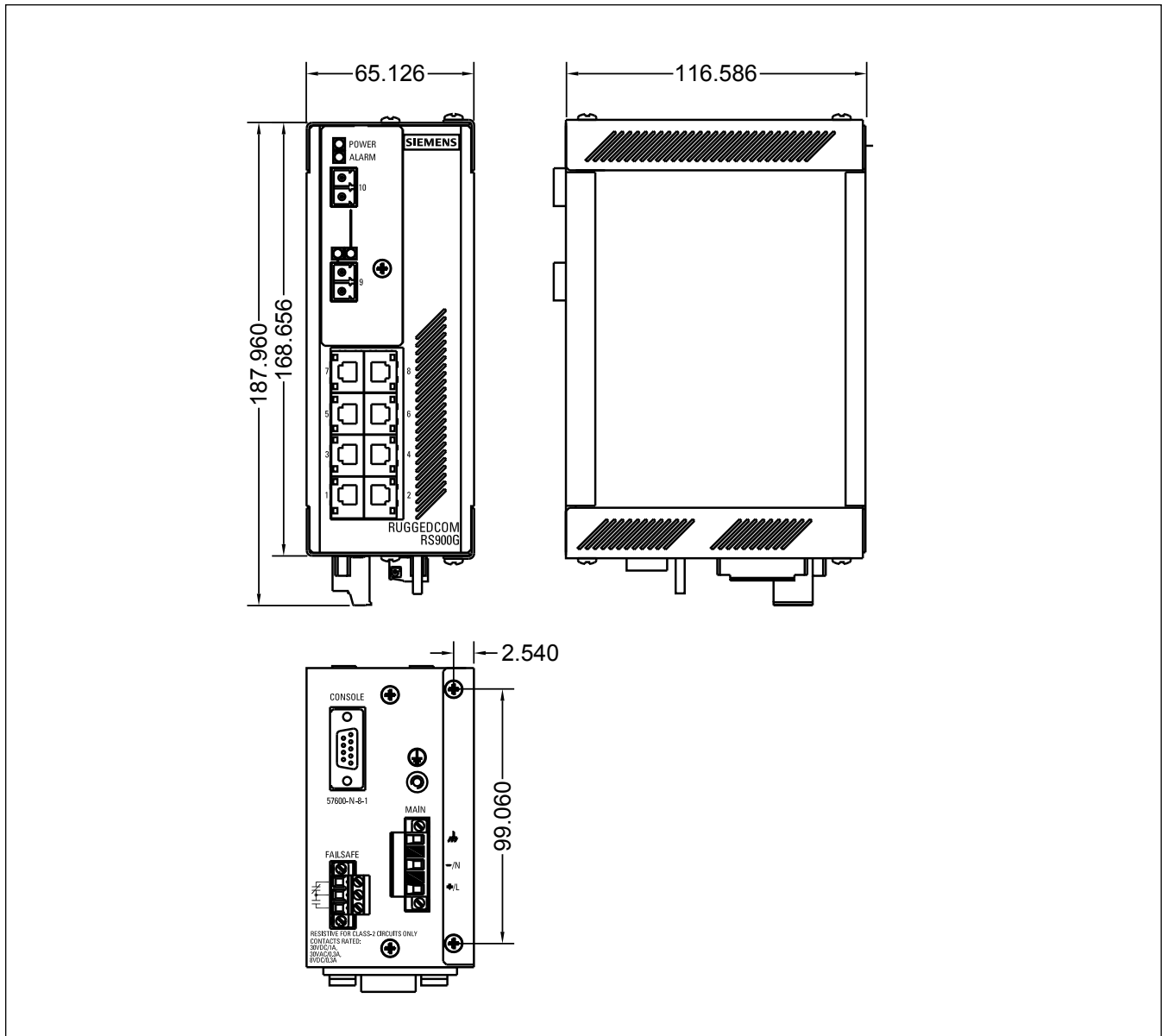

## Overall dimensions

All dimensions are in millimeters, unless otherwise stated.



# Dimension Drawings

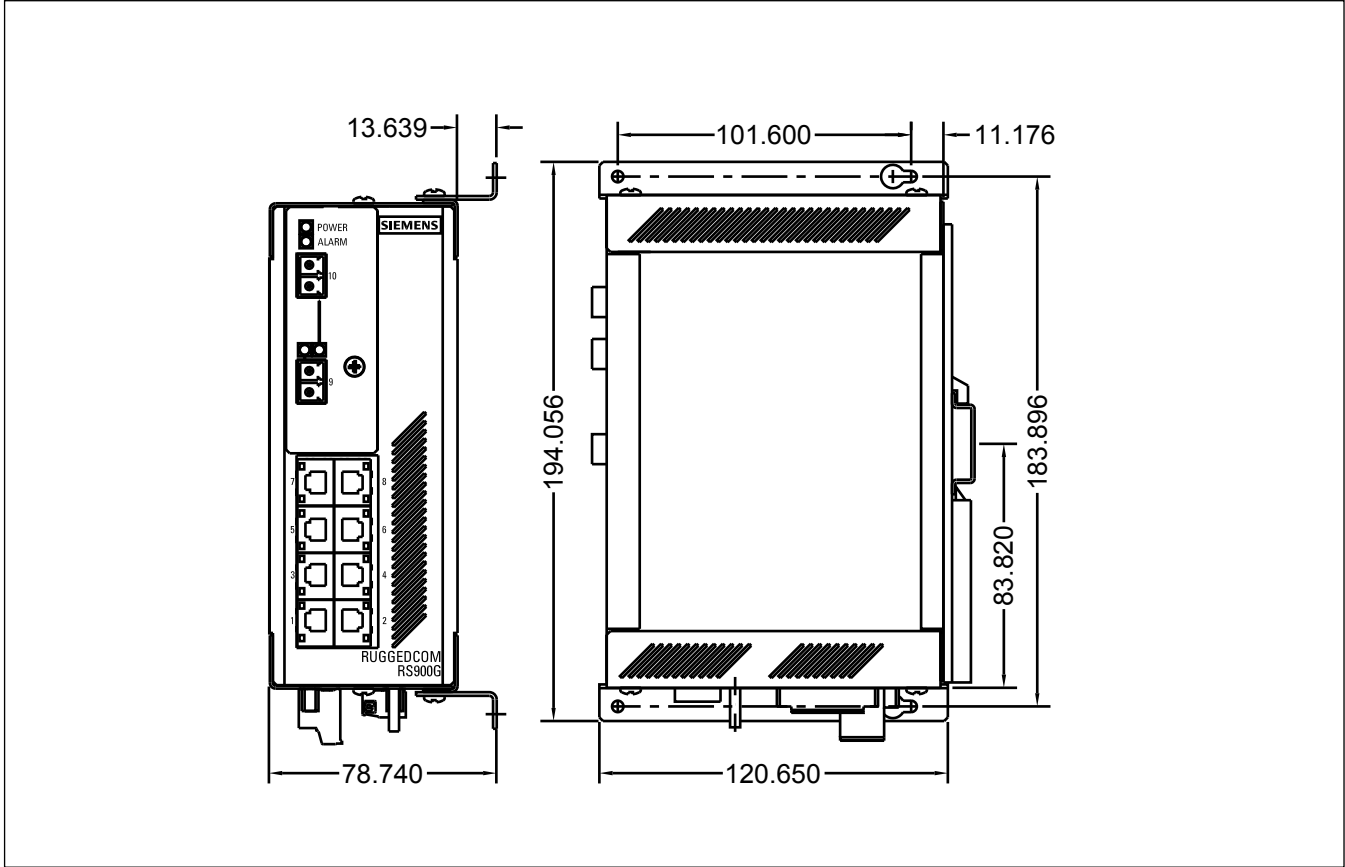

### Panel and DIN rail mount dimensions

All dimensions are in millimeters, unless otherwise stated.

## Order Codes

6GK60900GS2	-	_____	-	0	-	_____	-	A	-	_____	-	Z	_____
		PS1				Mount				MOD			P9P10

### PS1: Power Supply 1

1 = 24VDC (10-36VDC)

2 = 48VDC (36-72VDC)

3 = 88-300VDC or 85-264VAC

### Mount: Mounting Options

A = No mounting option

B = DIN rail mounting

C = Panel mounting

### MOD: Manufacturing Modifications

0 = None

1 = Conformal coating

### P9P10: Port 9 and Port 10 Transceiver Options

A01 = Dual 1000X SFP (Mini-GBIC). Order SFP optics separately.

A02 = Dual 1000SX Multimode LC 850nm 500m

A03 = Dual 1000LX Singlemode LC 1310nm 10km

A04 = Dual 1000LX Singlemode LC 1310nm 25km

A05 = Dual 1000LX Singlemode SC 1310nm 10km

A06 = Dual 1000LX Singlemode SC 1310nm 25km

### Options:

6GK6000-8BB00-0AA0KI = 6 ft power cable without lugs

## Example Order Codes

### 6GK6090-0GS21-0BA0-Z A02

24VDC Power Supply, DIN Rail Mount, Dual 1000SX Multimode LC 850nm 500m

### 6GK6090-0GS22-0CA1-Z A04

48VDC Power Supply, Panel Mount, Conformal Coating, Dual 1000LX Singlemode LC 1310nm 25km

### 6GK6090-0GS23-0AA1-Z A05

88-300VDC or 85-264VAC Power Supply, Conformal Coating, Dual 1000LX Singlemode SC 1310nm 10km

Siemens Industry, Inc.  
5300 Triangle Parkway  
Norcross, GA 30092

1-800-241-4453  
info.us@siemens.com

Subject to change without prior notice.  
All rights reserved.  
©2015 Siemens Industry, Inc.

The information provided in this brochure contains descriptions or characteristics of performance which in case of actual use do not always apply as described or which may change as a result of further development of the products. An obligation to provide the respective characteristics shall only exist if expressly agreed in the terms of contract. Availability and technical specifications are subject to change without notice.

All product designations may be trademarks or product names of Siemens AG or supplier companies whose use by third parties for their own purposes could violate the rights of the owners.

[usa.siemens.com/ruggedcom](http://usa.siemens.com/ruggedcom)