

WISE-4220

Industrial Wi-Fi 2.4G Module

Wireless I/O

NEW



Introduction

The WISE-4220 series is an Ethernet-based wireless IoT device, integrated with IoT data acquisition, processing, and publishing functions. As well as various I/O and sensor types, the WISE-4220 series provides data pre-scaling, data logic, and data logger functions. These data can be accessed via mobile devices and be published to the cloud with security at anytime and anywhere.

Features

IEEE 802.11 b/g/n 2.4GHz Wi-Fi with AP Mode

The Wi-Fi interface is easily integrated with wired or wireless Ethernet devices, users only need to add a wireless router or AP to extend existing Ethernet network to wireless. The limited AP mode enables the WISE-4220 to be accessed via other Wi-Fi devices directly as an AP.



HTML5 Web Configuration Interface

All the configuration interfaces are applied in web service, and the web pages are based on HTML5, so users can configure the WISE-4220 without the limitation of OS/devices. You can use your mobile phone or tablet to directly configure the WISE-4220.



Features

- 2.4GHz Wi-Fi reducing the wiring cost during big data acquisition
- Easily extend the existing network by adding APs, and share existing Ethernet software
- Configured by mobile devices directly without installing any software or Apps
- Zero data loss using the log function with RTC timestamp
- Data can be automatically pushed to Dropbox or computer
- Supports RESTful web API in JSON format for IoT integration

Data Storage

The WISE-4220 can log up to 10,000 samples of data with a time stamp. The I/O data can be logged periodically, and also when the I/O status changes. Once the memory is full, users can choose to overwrite the old data to ring log or just stop the log function.



Cloud Storage

Data logger can push the data to file-based cloud services like Dropbox using pre-configured criteria. With RESTful API, the data can also be pushed to a private cloud server in the format of JSON. Users can setup their private cloud server using the provided RESTful API and their own platform.



Specifications

General

- **WLAN Standard** IEEE 802.11b/g/n
- **Frequency Band** 2.4GHzISM Band
- **Transmit Power** 802.11b: 12.0 dBm ±1dBm
802.11g: 15.5 dBm ±1dBm
802.11n: 15.5 dBm ±1dBm
- **Antenna** Connector: Reverse SMA
Gain (Peak): 2.45 dBi
150m with line of sight
Plug-in screw terminal block (power)
- **Outdoor Range** System (1.6 second) and Communication (programmable)
- **Connectors** CE, FCC, IC, NCC, SRRC, RCM, VCCI, TELEC (CC3200 listed antenna)
- **Watchdog Timer** 70 x 102 x 38 mm
- **Certification** PC
DIN 35 rail, wall, stack, and d pole
- **Dimensions (W x H x D)** 10 ~ 50 V_{cc}
1.2 W @ 24 V_{cc}
- **Enclosure**
- **Mounting**
- **Power Input**
- **Power Consumption**
- **Power Reversal Protection**
- **Supports User Defined Modbus Address**
- **Supports Data Log Function** Up to 10000 samples with RTC time stamp
- **Supported Protocols** Modbus/TCP, TCP/IP, UDP, DHCP, and HTTP
- **Supports RESTful Web API in JSON format**
- **Supports Web Server in HTML5 with JavaScript & CSS3**
- **Supports System Configuration Backup and User Access Control**

Environment

- **Operating Temperature** -25 ~ 70°C (-13~158°F)
- **Storage Temperature** -40 ~ 85°C (-40~185°F)
- **Operating Humidity** 20 ~ 95% RH (non-condensing)
- **Storage Humidity** 0 ~ 95% RH (non-condensing)

WISE-4220-S231 (Built-in Temperature and Humidity Sensor)

Temperature Sensor

- **Operating Range** -25°C ~ 70°C (-13°F ~ 157.9°F)
- **Resolution** 0.1 (°C/°F/K)
- **Accuracy** ±2.0°C (±35.6°F) (vertical installation)

Humidity Sensor

- **Operating Range** 10 ~ 90% RH
- **Resolution** 0.1% RH
- **Accuracy** ±4% RH @ 0%~50% RH
±10% RH @ 50%~60% RH
±13% RH @ 60%~90% RH

WISE-S214 (4AI/4DI)

Analog Input

- **Channels** 4
- **Resolution** 16bits Bipolar; 15bits Unipolar
- **Sampling Rate** 10Hz (Total) with 50/60Hz Rejection
- **Accuracy** ±0.1% for Voltage Input; ±0.2% for Current Input
- **Input Range** 0~150mV, 0~500mV, 0~1V, 0~5V, 0~10V, ±150mV, ±500mV, ±1V, ±5V, ±10V, 0~20mA, ±20mA, 4~20mA
- **Input Impedance** >1M Ω (Voltage)
240 Ω (External resistor for current)
- **Support Data** Scaling and Averaging

Digital Input

- **Channels** 4 (Dry Contact)
- **Supports 200Hz Counter Input (32-bit + 1-bit overflow)**
- **Supports keep/discard counter value on power-off**
- **Support inverted digital input status**

WISE-S250 (6DI, 2DO & 1RS-485)

Digital Input

- **Channels** 6 (Dry Contact)
- **Supports 3kHz Frequency Input**

Digital Output (Sink Type)

- **Channel** 2
- **Output Current** 100 mA
At 0 -> 1: 100 us
At 1 -> 0: 100 us
(for Resistive Load)
- **Supports Pules Output** 5 kHz
- **Max. Load Voltage** 30V

Serial Port

- **Port Number** 1
- **Type** RS-485
- **Data Bits** 7, 8
- **Stop Bits** 1, 2
- **Parity** None, Odd, Even
- **Baud Rate (bps)** 1200, 2400, 4800, 9600, 19200, 38400, 57600, 115200
- **Protocol** Modbus/RTU (Total 32 addresses by 8 max. instructions)

WISE-S251 (6DI/1RS-485)

Digital Input

- **Channels** 6 (Dry Contact)
- **Supports 200Hz Counter Input (32-bit + 1-bit overflow)**
- **Supports keep/discard counter value on power-off**
- **Support inverted digital input status**

Serial Port

- **Port Number** 1
- **Type** RS-485
- **Data Bits** 7, 8
- **Stop Bits** 1, 2
- **Parity** None, Odd, Even
- **Baud Rate (bps)** 1200, 2400, 4800, 9600, 19200, 38400, 57600, 115200
- **Protocol** Modbus/RTU (Total 32 address by max. 8 instructions)

Ordering Information

Wi-Fi 2.4G Wireless I/O Module

- **WISE-4220-A** Wi-Fi 2.4G Wireless I/O Module
- **WISE-4220-S231-A** Wi-Fi 2.4G Wireless Module with Temperature and Humidity Sensor

WISE-S200 I/O Module

- **WISE-S214-A** 4AI/4DI
- **WISE-S250-A** 6DI, 2DO & 1RS-485
- **WISE-S251-A** 6DI & 1RS-485

Accessories

- **PWR-242-AE** DIN Rail Power Supply (2.1A Output Current)
- **PWR-243-AE** Panel Mount Power Supply (3A Output Current)
- **PWR-244-AE** Panel Mount Power Supply (4.2A Output Current)

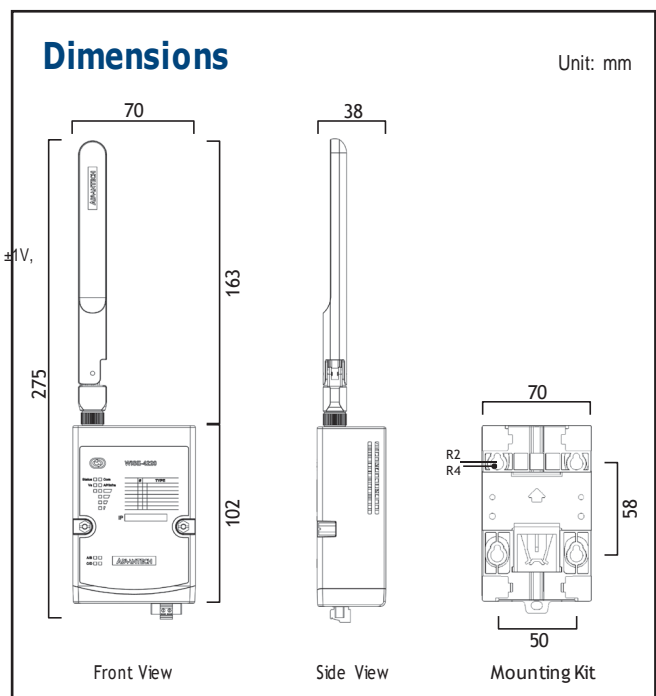

Industrial Communication Products Ltd

Tel: +44(0) 203 086 9569

Web: www.industrialcomms.com

Email: sales@industrialcomms.com