

WISE-4610

Advanced Industrial LoRa/LoRaWAN Wireless I/O Module



Introduction

LPWAN is a type of wireless telecommunication wide area network designed to allow long range communications at a low data rate among IoT applications, such as sensors operated on a battery. Its benefits is to offer multi-year battery lifetime for sensors/ applications to send small amounts of data over long distances a few times per hour suitable for different environments.

Private LoRa and LoRaWAN are one category of LPWAN which belong to the non-cellular LPWAN wireless communication network protocols enables very long range transmissions with low power consumption, operating in the non-licensed spectrum.



Star Topology

The LoRaWAN networks in a star topology have gateway relaying the data between the sensor nodes and the network server.

Communication between the sensor nodes and the gateway goes over the wireless channel utilizing the LoRa physical layer, whilst the connection between the gateways and the central server are handled over a backbone IP-based network.

The LoRaWAN end nodes (sensors) typically use Low Power and are battery powered (Class A and Class C). LoRa embedded sensors that run on batteries that lasts from 2–5 years typically. The LoRa sensors can transmit signals over distances from 1 km—10 km.

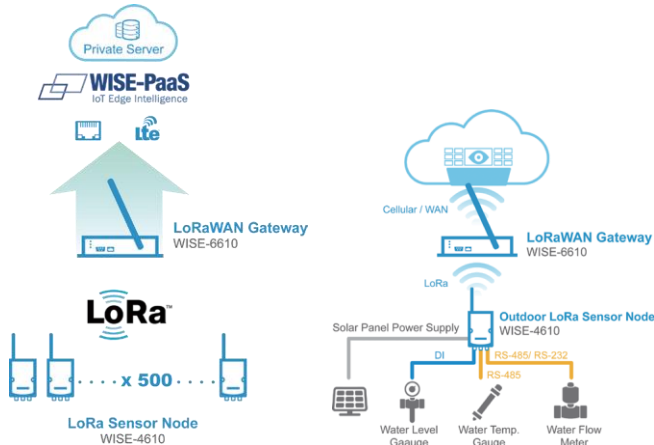

Features

- ③ Private LoRa and LoRaWAN selectable
- ③ Longer communication range
- ③ Better penetration through concrete and steel
- ③ Less interference than 2.4GHz spectrum
- ③ Application-ready I/O combination with IP65 enclosure
- ③ Powered by solar rechargeable battery or 10~50V_{DC} input
- ③ GPS/Galileo/BeiDou/GLONASS support

Common Specification

Wireless Communication

③	Standard	LoRaWAN or Private LoRa
③	Private LoRa Frequency Range & Region*	
		EU 863-870 (MHz)
		US 902-928 (MHz)
		JP 915-928 (MHz)
③	LoRaWAN Frequency Range & Region*	
		EU 868
		NA 915
		JP 923
		AS 923
	* Other region can be supported upon request	
③	Spreading Factor	7~12
③	Outdoor Range	15Km (L.o.S) by pairing with WISE-6610 (with 2dBi Antenna)
③	Transmit Power	Up to +18dBm
③	Receiver Sensitivity	Up to -136dBm at SF = 12 / 125KHz
③	Data Rate	50 kbps at FSK mode EU868 21.9 kbps at SF7 mode US915 5.47 kbps at SF7 mode JP923
③	Topology	Star
③	Function	End Node
③	Antenna Type	External

GPS (Only Supported on WISE-4610P)

③	GNSS Systems	GPS, GLONASS, Galileo, BeiDou, QZSS and SBAS signals
③	Max. Update Rate	Single GNSS: up to 18 Hz
③		Concurrent GNSS: up to 10 Hz
③	Accuracy	Position: 2.5 m CEP (50% confidence) With SBAS: 2.0 m CEP (50% confidence)
③	Acquisition	Cold starts: 57 s Aided starts: 7 s
③	Antenna Type	Internal

General		③	Resolution 15 bits
③ Power Input	WISE-4610P Built-in 4100mAh Lithium rechargeable battery pack 10~50V _{DC} external power 17-21V _{DC} Solar Panel	③	SamplingRate 1 Sample/s (MAX)
③	WISE-4610 10~50V _{DC} external power		
③	Battery Life 6 months (1 hour data update and 1 day GPS update)		
③ B USB	Configuration Interface Micro-		
③ Rx, Battery/Signal Level	LED Indicator Status, Error, Tx,		
③ stack	Mounting DIN 35 rail, wall, pole, and		
③	Dimension (W x H x D) 82 x 122 x 49 mm (without antenna)		
Operating Temperature			
③	With rechargeable battery 0 ~ 60 °C (32 ~ 140 °F)		
③	Without battery -25 ~ 70 °C (-13 ~ 158 °F)		
Storage Temperature			
③	With rechargeable battery -20 ~ 60 °C (-4 ~ 140 °F)		
③	Without battery -40 ~ 85 °C (-40 ~ 185 °F)		
③	Operating Humidity 5 ~ 95% RH (non-condensing)		
③	Storage Humidity 0 ~ 95% RH (non-condensing)		

WISE-S614 (4AI/4DI)

Analog Input

③	Channels 4
③	Resolution 16-bit
③	Sampling Rate 1Hz per channel
③	Accuracy ±0.1% of FSR (Voltage) ±0.2% of FSR (Current)
③ Input Range	±150mV, ±500mV, ±1V, ±5V, ±10V, 0 ~ 150mV, 0 ~ 500mV, 0 ~ 1V, 0 ~ 5V, 0 ~ 10V, 0 ~ 20mA, 4 ~ 20mA, ±20mA
③ Input Impedance	>2M [∧] (Voltage) 240 [∧] (External resistor for current)
③	Isolation Voltage 2000 V _{DC}
③	Common Mode Voltage 350 V _{DC}
③	Drift Unipolar ±100ppm Bipolar ±50ppm
③	Burn-out Detection Yes (4~20mA only)
③	Supports Data Scaling and Averaging

Digital Input

③	Channels 4
③	Input Type Dry Contact (Wet Contact by request)
③	Logic Level 0: Open 1: Close to DI COM
③	Supports 200Hz Counter Input (32-bit + 1-bit overflow)
③	Keep/Discard Counter Value when Power-off
③	Supports Inverted DI Status

WISE-S615 (4 RTD)

Analog Input

③	Channels 4 differential
③	Input Connections 2, 3-wire
③	Input Impedance 10 M [∧]

- ③ **RTD Types and Temperature Ranges**
 - Pt 100 RTD**
 - RTD 100 (a = 0.00385) -200°C to 600°C
 - RTD 100 (a = 0.00392) -200°C to 600°C
 - Pt 1000 RTD**
 - Pt -40°C to 160°C
 - Accuracy** ±0.1% FSR
 - 90 dB
 - 60 dB
 - Span Drift** ± 25 ppm/°C
- ③ **CMR @ 50/60 Hz**
- ③ **NMR @ 50/60 Hz**
- ③

WISE-S617 (2AI/2DI/1DO/1RS-485)

Digital Input

- ③ **Channel** 2
- ③ **Logic Level (Dry Contact)** 0: Open
1: Close to DI COM
- ③ **Non-isolation**
- ③ **Supports 32-bit counter**
- input function (maximum signal frequency: 200 Hz)**
- ③ **Supports keep/discard counter value when power OFF**
- ③ **Supports frequency input function (maximum signal frequency: 200 Hz)**
- ③ **Supports inverted digital input status**

Analog Input

- ③ **Channels** 2
- ③ **Resolution** 16 bit
- ③ **Sampling Rate** 1 Hz per channel
- ③ **Accuracy** ±0.1% of FSR (Voltage)

- ③ **Input Range** ±0.2% of FSR (Current)
±1V, ±5V, ±10V, 0~1V, 0~5V, 0~10V, 0~20mA, 4~20mA, ±20mA
- ③ **Input Impedance** > 2M \wedge (Voltage)
120 \wedge (External Resistor for Current)
- ③ **Isolation Voltage** 2000 V_{DC}
- ③ **Common Mode Voltage** 350 V_{DC}
- ③ **Drift**
 - Unipolar
 - ±100ppm
 - Bipolar
 - ±50ppm
- ③ **Burn-Out Detection** Yes (4~20mA only)
- ③ **Supports data scaling and averaging**

Digital Output

- ③ **Channel** 1 (Sink Type)
- ③ **Non-isolation**
- ③ **Output Current** 100mA

COM Port

- ③ **Port Type** RS-485
- ③ **Baud Rate (bps)** 1200, 2400, 4800, 9600, 19200, 38400, 57600, 115200
- ③ **Data Bits** 7, 8
- ③ **Stop Bits** 1, 2
- ③ **Parity** None, Odd, Even
- ③ **Flow Control** Auto flow control
- ③ **Signals** DATA+ and DATA-
- ③ **Protection** 15 kV ESD
- ③ **Supported Protocols** Modbus/RTU (Up to 32 addresses with a maximum of 8 instructions)

WISE-4610

WISE-S672 (6DI/1RS-485/1RS-485 or RS-232)

COM Port

③	Port Number	2
③	Type	COM1: RS-485 COM1: RS-485/232
③	Serial Signal	RS-485: DATA+, DATA- RS-232: Tx, Rx, GND
③	Data Bits	7, 8
③	Stop Bits	1, 2
③	Parity	None, Odd, Even
③	Baud Rate (bps)	1200, 2400, 4800, 9600, 19200, 38400, 57600, 115200
③	Protection	15 kV ESD
③	Protocol	Modbus/RTU (Total 32 address)

Digital Input

③	Channels	6
③	Input Type	Dry Contact
③	Logic Level	0: Open 1: Close to DI COM
③	Supports 200Hz Counter Input (32-bit + 1-bit overflow)	
③	Keep/Discard Counter Value when Power-off	
③	Supports Inverted DI Status	

Ordering Information

WISE-4610 Advanced Industrial LoRaWAN Module

③	WISE-4610-NA	Advanced Industrial LoRaWAN Module - NA915
③	WISE-4610-EA	Advanced Industrial LoRaWAN Module - EU868
③	WISE-4610-JA	Advanced Industrial LoRaWAN Module - AS923
③	WISE4610JA2001-T	Advanced Industrial LoRaWAN Module - TW923
③	WISE-4610P-NA	Advanced Industrial LoRaWAN I/O Module w/ GPS & battery - NA915
③	WISE-4610P-EA	Advanced Industrial LoRaWAN I/O Module w/ GPS & battery - EU868
③	WISE-4610P-JA	Advanced Industrial LoRaWAN I/O Module w/ GPS & battery - AS923
③	WISE4610PJA2001-T	Advanced Industrial LoRaWAN I/O Module w/ GPS & battery - TW923

WISE-S600 IP65 I/O Module with M12 Connectors

③	WISE-S614-A	4AI/4DI
③	WISE-S615-A	4RTD
③	WISE-S617-A	2AI/2DI/1DO/1RS-485 w/ 2ch 12V _{DC} power output
③	WISE-S672-A	6DI/1RS-485/1RS-485 or RS-232

WISE-S600T I/O Module with Terminal Block

③	WISE-S614T-A	4AI/4DI
③	WISE-S617T-A	2AI/2DI/1DO/1RS-485 w/ 2ch 12V _{DC} power output

Accessories

③	1654011516-01	M12, A-code, 8 Pin, Male
---	----------------------	--------------------------

③	1655005903-01	M12, A-code, 4 Pin, Female
③	1700028162-01	M12, A-code, 4 pin, Female with 1M cable
③	1700028163-01	M12, A-code, 8 Pin, Male with 1M cable
③	PWR-242-AE	DIN Rail Power Supply (2.1A Output Current)
③	PWR-243-AE	Panel Mount Power Supply (3A Output Current)
③	PWR-244-AE	Panel Mount Power Supply (4.2A Output Current)

Pin Assignment

Model Name	M12 Cable	WISE-S614	WISE-S615	WISE-S617	WISE-S672	
Pin Number						
P/N	4Pin : 1700028162-01 8Pin : 1700028163-01	WISE-S614-A	WISE-S615-A	WISE-S617-A	WISE-S672-A	
A	1	White	DI0	RTD2+	AI0+	DI0
	2	Brown	DI1	RTD2-	AI0-	DI1
	3	Green	DI2	RTD2 COM	+12V Out0	DI2
	4	Yellow	DI3	NC	+12V Out GND	DI3
	5	Gray	NC	RTD3+	AI1+	DI4
	6	Pink	NC	RTD3-	AI1-	DI5
	7	Blue	NC	RTD3 COM	+12V Out1	NC
	8	Red	DI COM	NC	+12V Out GND	DI COM
B	1	White	AI0+	RTD0+	DI0	RS-485 D1-
	2	Brown	AI0-	RTD0-	DI1	RS-485 D1+
	3	Green	AI1+	RTD0 COM	DI COM	RS-232 TX

B	4	Yellow	AI1-	NC	DO0	RS-232 RX
	5	Gray	AI2+	RTD1+	DO GND	RS-485 D2-
	6	Pink	AI2-	RTD1-	RS-485 D+	RS-485 D2+

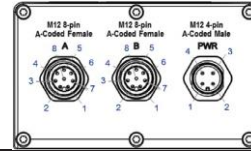

WISE-4610

PWR	7	Blue	AI3+	RTD1 COM	RS-485 D-	NC
	8	Red	AI3-	NC	RS-485 GND	RS-232 GND
	1	Brown	+VS	+VS	+VS	+VS
	2	White	-VS	-VS	-VS	-VS/ SP-
PWR	3	Blue	SP+	SP+	SP+	SP+
	4	Black	SP-	SP-	SP-	NC

Dimensions

Unit: mm

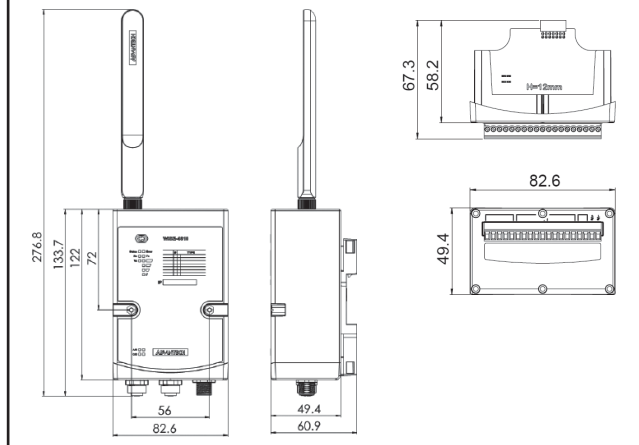

Wireless IoT Sensing Devices